

19



Europäisches Patentamt
European Patent Office
Office européen des brevets



11 Publication number:

0 322 487 B1

12

EUROPEAN PATENT SPECIFICATION

45 Date of publication of patent specification: **14.10.92** 51 Int. Cl.⁵: **A41D 1/06, A41D 27/08**

21 Application number: **87311438.3**

22 Date of filing: **24.12.87**

54 **Article of dress.**

43 Date of publication of application:
05.07.89 Bulletin 89/27

45 Publication of the grant of the patent:
14.10.92 Bulletin 92/42

84 Designated Contracting States:
AT BE CH DE ES FR GB GR IT LI NL SE

56 References cited:
FR-A- 2 272 622
FR-A- 2 361 802
FR-A- 2 475 376
GB-A- 2 074 438

73 Proprietor: **Hofman, Velimir**
Slagenburg 10
NL-1082 JW Amsterdam(NL)

72 Inventor: **Hofman, Velimir**
Slagenburg 10
NL-1082 JW Amsterdam(NL)

74 Representative: **Cline, Roger Ledlie**
EDWARD EVANS & CO. Chancery House
53-64 Chancery Lane
London WC2A 1SD(GB)

EP 0 322 487 B1

Note: Within nine months from the publication of the mention of the grant of the European patent, any person may give notice to the European Patent Office of opposition to the European patent granted. Notice of opposition shall be filed in a written reasoned statement. It shall not be deemed to have been filed until the opposition fee has been paid (Art. 99(1) European patent convention).

Description

The present invention relates to improvements of articles of dress, for wear on the leg both indoors and outdoors.

Many articles of dress extending at least in part over the lower part of the body are known, such as dresses, skirts, trousers and breeches. These are all suitable for both indoor and outdoor wear.

There are other articles of protective clothing, such as raincoats and leg protectors, which cover at least part of the lower part of the body, but are not intended for both indoor and outdoor wear, and accordingly do not constitute an article of dress as defined and used in this specification.

Other articles covering at least in part the lower part of the body are described by Way (U.S. Patent No. 332, 630) and McCrahan (U.S. Patent No. 1, 367,065). These are glove-fitting, that is, they adhere closely to the part of the human body it extends over, over its full length.

The present invention is directed to an article of dress which extends at least in part over the lower part of the body and can be worn both indoors and outdoors.

It is therefore a primary object of the invention to provide an outer garment which can be worn continuously all day in a normal manner both indoors and outdoors.

It is another object of the invention to provide an article of dress having different sections which can be tight-fitting, partially tight-fitting, loose fitting, or partially loose-fitting.

It is still another object of the invention to provide an article of dress which can be worn in combination with at least one other article of apparel covering at least the upper and middle part of the body.

My earlier disclosure GB-A-2074438 is couched in very vague terms, but may be taken to suggest the features set out in the introductory parts of claims 1 and 5. I have now improved the suggestions of that disclosure by providing an article of apparel which is more comfortable and more decorative, incorporating the characterising feature of either of these two claims. The articles may constitute the first piece of another article which also comprises a second piece for covering at least a portion of the torso of the wearer in the region of the abdomen and hips and a substantial portion of only one leg of a wearer, leaving the other leg exposed, whereby said first piece can be viewed when worn on the other leg of the wearer. All the other features mentioned in the remainder of this section of the specification are presently envisaged as optional features, even if they are stated to be according to the invention.

The article of dress according to the invention

can be made out of various types of material, including but not limited to materials presenting a substantially continuous surface, materials presenting a discontinuous surface, as described hereinafter, materials partially incorporating non-foldable materials (such as metals, plates and shells), at least partly foldable materials and combinations thereof. Generally, a water resistant or water-repellant material will not be required unless the article of dress is required as for protection against wet or inclement weather conditions.

In one embodiment the article consists of three principal sections, an upper section, a middle section, and a lower section. The middle section covers from about 5 cms. above to about 5 cms. below the kneecap. The upper section and the lower section cover the areas respectively above and below the middle section. The fit of the tubing in each of the three sections can be either loose-fitting, that is not adhering to the leg, tight-fitting, that is adhering to the leg, or partially loose-fitting, or partially tight-fitting, as defined hereinafter. The article is made to fit in such a way that when worn it has a shape distinct from that of a leg and when worn is partly freely suspended. All types of fit within one section (partially loose-fitting) are possible and can be used in any arrangement desired. When a plurality of types of fit are provided in one section, either tight-fitting or loose-fitting will dominate the overall fit of one complete section of the tubing.

For various types of fits the following definitions are used:

- a) Loose (Tight)-fitting means the fitting is loose (tight)-fitting throughout the complete length of the section, and
- b) Partially loose (tight)-fitting means there is more than one type of fit within the section and that loose (tight)-fitting dominates the overall fit of the section.

When the article of dress according to the invention comprises a single unit of tubing for wear on one leg only, the wearer is free to choose whether or not two single units of tubing will be worn simultaneously instead of one single unit of tubing and whether, if two single units are worn, they are to be completely identical or not.

The article of dress according to the invention can consist of two pieces, the first piece and the second piece. Whereas the first piece corresponds to the tubing described hereinabove and hereinafter, the second piece is covering at least a portion of the torso of the wearer in the region of the abdomen and hips and a substantial portion of only one leg of a wearer, leaving the other leg exposed, whereby said first piece can be viewed when worn on the other leg of the wearer.

The article of dress according to the invention

has a length allowing it to start from any part of the upper leg and to extend to any point of the lower leg and in the extreme to extend the full length of the leg. In general the length of the article of apparel is not critical. Accordingly, it is possible to design and adapt the article of dress to cover the required number of sizes for individual wearers by a limited number of sizes as far as the length of the article of dress is concerned.

The hemline can be parallel to the floor, at an angle to the floor, or a combination of the two.

The hemline can also consist of varieties of uneven lines consisting of at least two lines placed at an angle to each other. Examples include but are not limited to a zig-zag line, an undulating line and a curve. The hemlines also can be continuous or discontinuous, such as when formed by fringe or of a plurality of pieces of material at the hemline.

The article of dress can have any combination of continuous and discontinuous hemlines.

The article of dress can be formed from one piece of material, of which two sides are at least partly connected to each other, or from two or more pieces of material of which the sides are at least partly connected to each other, in any suitable manner utilizing at least one kind of connecting means, such as for example a seam, a zipper, self-adhesive tape, snaps, strings or knots or any other means for fastening together at least partly two sides of one piece of material. The article of dress can also contain more than one seam or another suitable connecting means.

If the article of dress includes more than one connecting means, these means can be colinear with each other and either adjacent to or spaced apart from each other. They can also be parallel to each other and even be positioned at an angle to each other. The connecting means also can be formed in straight lines or irregular lines.

The size and shape of the piece or pieces of material from which the article of dress is made is determined by the design and fit of the article. Accordingly, there are no limitations to the arrangement or position of the particular connecting means.

The material used to make the article of dress comprises at least in part foldable material, which can be located at any position in the article of apparel. The material also can comprise in part non-foldable material, which also can be located in any position.

The article of dress can have a substantially continuous surface, e having at most minute discontinuities, such as in cloth as used for suits as used or dresses, or a discontinuous surface, in which the discontinuities are of considerable size.

The discontinuous surface can comprise openings made in the material itself, alternatively by

cutting off or shaping the material or by cutting out pieces of the article of apparel. The openings can also be made as the result of the arrangement of the various pieces of material. The openings can be of regular size at regular (=equal) distances, regular size at irregular (=unequal) distances, irregular size at regular distances, irregular size at irregular distances and combinations thereof.

In another embodiment of the invention the article of dress can include at least one inflatable air-pocket. The air-pocket can be provided with at least one air-tube and an air-valve located in such a manner, that it is easily accessible if required. Protective material can be attached to the tubing or the lining of the article of apparel to cover the air-tube or the complete air-pocket system from inside. The air-valve can be positioned in a stitched-on pocket, located on the outside part of the article of dress or alternatively in a built-in pocket on the inside of the article of dress. The air-valve allows inflation of the air-pocket to any desired degree using any suitable gas, preferably air. An inflated air-pocket can be used to attach the article of dress to the leg. This may allow better blood circulation and better prevent slippage than some other conventional attachment means for attaching the article of dress to the leg. Additionally the inflated air-pocket can provide a desired shape under the article of dress. One may wish to inflate the air-pocket, for example only, as the attachment means, for fashionable or decorative reasons, to hide and/or improve the form of a leg, for temperature insulation purposes and for other reasons. For young children one might wish to inflate the area of the knee to protect it against injuries. The air-pocket according to the invention can be located at any position of the article of dress and in any arrangement, size and number. The air-valve can be located directly on the air-pocket (eliminating the air tube). Also the protective material utilized for covering the air-tube or the air-pocket system is not compulsory. The air-pockets can be located within the article of dress when the tubing is made out of air-tight material, or the air-pockets can be fastened to the tubing.

The article of dress always covers the knee and the kneecap and at least partly covers the upper and lower leg. The upper part of the upper leg can be at least partly uncovered.

Irrespective of the number of pieces of material the article of dress is made of, the tubing can include auxiliary articles such as functional buttons, decorative buttons, buttonholes, pockets, decorative seams and built-in pockets.

The article of dress can also include attached articles located outside the place of the tubing and attached to the tubing such as linings, fillings, pockets, reinforcements and straps.

The article of dress can be provided with a special pattern imposed on the surface to present a discontinuous surface to decrease the aeration inside the tubing and/or to add to the artistic and fashionable value. Special patterns, imposed onto the surface of the tubing, constitute attached articles as well.

An additional feature of the invention is that pockets and straps are suitable for carrying articles, such as for example pencils, keys or a purse.

The auxiliary and attached articles can be located at any position on the article of dress.

The article of dress according to the invention can be attached to the leg or other suitable part of the body by attachment means in some conventional mode as for example by straps, strings, elastic materials, self-adhesive tapes, crimped fibres, a garter, a corset or the like.

The attachment means can constitute a part of the article of dress; alternatively they can be separate from the article of dress or as in the case of buttons and button holes or crimped fibres, for example, the attachment means can constitute partly a part of the article of dress and partly separate therefrom.

Generally, the attachment means will be placed circumferentially around the leg, the exception being, as an example, self-adhesive tape which need extend only a part of the circumference of the article of dress.

The attachment means can be situated in the upper part of the tubing. When the attachment means is so situated, it can leave the upper end free and loose-fitting allowing it to be more easily put on. When no attachment means are utilized both the upper part of the tubing and the upper end of the tubing can be freely suspended or fitted in any other convenient way. On the lower part and lower end of the article of dress, conventional attachment means can be applied or the article of dress can be provided with various alternative fittings including fittings enabling the article of dress to be left completely freely suspended from the leg when worn. Alternatively the article of dress can be provided with a construction comprising a string or elastic or elastomer or elastic fibre, which gives the tubing the shape of harem trousers.

According to the invention the tight fitting attachment portion of the tubing serves for engaging a part of the leg of the wearer for supporting the article of dress thereon, whereby the loose-fitting portion serves to allow ambient air to engage at least a portion of the leg of the wearer.

The article of dress according to the invention may or may not comprise attachment means of its own. The spirit of the invention is not changed when the attachment means utilized attach to any

other suitable part of the body.

In another embodiment, the article of dress includes a pressed-in crease or a plurality of pressed-in creases.

In addition, the article of dress according to the invention can be provided with cuffs at the lower end.

The article of dress according to the invention can be translucent, transparent or opaque, as desired. It can consist of any suitable materials such as woven or knitted materials manufactured from natural fibres, man-made fibres, or materials not made out of fibres and any mixture thereof; natural fibres consisting of cellulose base, protein base or mineral base fibres and man-made fibres consisting of a natural polymer base, synthetic polymer base and inorganic base fibre, as well as non-woven materials, such as leather, synthetic leather, rubber, plastic foils, plates and other forms made of different types of materials; rubber and any mixture thereof; as well as any mixture of materials made out of fibres and materials which are not made out of fibres.

Because the article of dress covers the leg only, the material used in making it can be a very light material and/or transparent material as articles of dress covering the leg are subject to less tear and wear than articles covering the leg and some other part of the body.

The article of dress according to the invention can be made, for example, out of very lightweight transparent material, such as fabrics weighing 100 g/m². It is expected that such fabrics will not be particularly resistant to breaking and tearing according to ASTM Designation D 1682 and D2262.

A better understanding of the disclosed embodiments of the invention will be achieved when the accompanying detailed description is considered in conjunction with appended drawings in which:

FIGURE 1 is a front elevational view of a first embodiment of the invention, in use on the lower part of the human body;

FIGURE 2 is a front elevational view of a second embodiment of the invention, in use on a human left leg;

FIGURE 3 is a left side elevational view of a third embodiment of the invention in use on a human left leg;

FIGURE 4 is a left side elevational view of a fourth embodiment of the invention, in use on a human left leg;

FIGURE 5 is a left elevational view of a fifth embodiment of the invention, in use on a human left leg;

FIGURE 6 is a left side elevational view of a sixth embodiment of the invention, in use on a human left leg;

FIGURE 7 is a cross-sectional view of the embodiment of Figure 6, taken along line a-a of Figure 6;

FIGURE 8 is a front elevational view of a seventh embodiment of the invention, in use on a human left leg;

FIGURE 9 is a front elevational view of an eighth embodiment of the invention, in use on the lower part of the human body;

FIGURE 10 is a front elevational view of a ninth embodiment of the invention, in use on a lower part of the human body; and

FIGURE 11 is a front elevational view of a tenth embodiment of the invention, in use on a lower part of the human body.

The articles of dress illustrated in the drawings are wholly or partly for use as a decorative leg covering for a single leg, being tubing of decorative lightweight material and capable of being worn as a single unit covering only one leg from above the knee to below the knee.

As shown in Figure 1, tubing 10 comprises one piece of material 12. The tubing covers the area from somewhere on the upper part of the leg to the ankle. The tubing has an upper section 10a at least 2.5cm long and is tight-fitting at 14 in the middle part of the upper section 10a and loose-fitting above and below 14, loose-fitting in the middle section 10b, and partially loose-fitting in the lower section 10c being tight-fitting at 18a and 18b. The upper part 16 of the tubing 10 is loose-fitting and has an upper terminal edge 13 which is undulating in the preferred embodiment. The upper part 16 is attached to the leg from below by attachment means 14. The tubing 10 in section 10c is tight-fitting on the wearer's leg at two locations determined by elastic strips 18a and 18b. Between these two locations of elastic strips 18a and 18b the tubing 10 is loose-fitting. The lower terminal edge 15 of the tubing occurs at the lower edge of the strip 18b.

As shown in Figure 2, tubing 20 comprises a plurality of pieces of material 22a, 22b, and 22c covering an area from the upper leg to the ankle. Tubing 20 is partially loose-fitting at the upper section 20a, tight-fitting at the middle section 20b, and loose-fitting at the lower section 20c. The three pieces of material 22a, 22b, and 22c, are interconnected by interconnecting means 23 and a seam 24 positioned parallel to each other. The upper section 20a of tubing 20 can be opened out and is secured by connecting means comprising self-adhesive tape 25. The middle section 20b of the tubing 20 is made out of elastic material, so that the complete area around the knee is tight-fitting on the leg. The tubing 20 is provided with four pockets 26a, 26b, 26c, and 26d in various positions and the lower part 20c of tubing 20 includes an

open-ended inverted V-shaped opening 27 extending to the interconnecting means 23. Pockets 26a, 26b, 26c and 26d are provided with decorative stitching 28. The lower section 20c is at least 2.5 cm. long.

As shown in Figure 3, tubing 30 comprises a plurality of longitudinal spaced-apart pieces of material 31a, 31b, 31c, 31d, 31e, 31f, etc. covering an area from the upper leg to the ankle. Tubing 30 is loose-fitting at the upper and middle sections 30a and 30b and partially loose-fitting with a tight fitting elastic strip portion 31 positioned in the lower section 30c, leaving the lower part of the lower section 30c loose and thus freely suspended from the leg 1. The pieces of material 31a, 31b, etc. are interconnected at the upper end by a ribbon type material 32 and by a trapezoid-shaped piece of material 33 at the lower end. The ribbon type material 32 and the trapezoid-shaped piece of material 33 are connected to pieces of material 31a, 31b, etc. by seams 34 and 35 respectively. The ribbon type material 32 is provided with decorative stitching 36. The lower section 30c is at least 2.5 cm. long. The top portion of the tubing is supported by a vertical ribbon 37 extending to above the wearer's leg for fixing either to the wearer's body or to another article of clothing. The ribbons 37 are similarly provided in other embodiments.

As shown in Figure 4, tubing 40 comprises a discontinuous surface including see-through openings having an area of at least 3mm² and large openings having an area of at least 50mm² covering an area from the upper edge 41 at the hipbone down to the lower edge 48 at the ankle. Tubing 40 is loose-fitting at the upper section 40a, partially loose-fitting at the middle section 40b, and loose-fitting at the lower section 40c. A lining 42 extends through the upper part of section 40a. A netting material 43 covers the lined upper section 40a and part of the unlined lower section 40c. For the middle section 40b of tubing 40, different material 44a is used, interconnected to the upper and lower sections 40a and 40c by interconnecting means comprising seams 45a and 45b. Elastic strips 46a and 46b are used as tight-fitting attachment means between which the tubing 40b is loose-fitting. Tubing 40 further comprises a decorative seam 47, securing material 44b on the base of the netting 43 of the lower section 40c.

As shown in Figure 5, tubing 50 comprises a discontinuous surface including see-through openings 52a and large openings 52b - 52d, covering the area from about the level of the ischium down to the extreme lower part of the leg 1. Tubing 50 is loose-fitting at the upper section 50a, and partially loose-fitting at the middle and lower sections 50b and 50c. It is made out of five different interconnected sections of material 51a, 51b, 51c, 51d and

51e interconnected to form a tube. First section 51a has regularly shaped openings 52a at regular distances, and has regularly shaped openings 52b at irregular spacing, third section 51c has irregularly shaped openings 52c at regular spacings and fifth section 51e has irregularly shaped openings 52d at irregular spacings. A zig-zag seam 53 partly connects pieces of the section of material 51a dividing openings 52a from openings 52b. 51b is a ribbon-type tight-fitting elastic material situated between the lower part of middle section 50b and the upper part of lower section 50c. Ribbon type sections of material 51b and 51d and seams 56a, 56b, 56c and 56d interconnect the sections of material 51a, 51c, and 51e. Tubing 50 further comprises an open-ended inverted V-shaped opening 57 extending through the whole depth of the fifth section 51e. The tubing 50 has an upper edge 54 and lower edge 58.

As shown in Figure 6, tubing 60 includes inflatable air-pockets 61a and 61b, the upper air pocket 61a covers an area within the upper section 60a and below the loose-fitting upper end of the tubing 60. The upper end is provided with gripping means 62 for aiding in pulling up tubing 60 over the leg, having an upper edge 66. The middle section 60b and the lower section 60c are loose-fitting. Section 60c has a lower edge 67. An air pocket 61a in the upper section provides a round shape and serves as attachment means for attaching tubing 60 to the leg. Tubing 60 further comprises a lower air pocket 61b in the middle section 60b in the vicinity of the knee. An air valve 63 positioned in a conventional pocket 64 is connected to air-pockets 61a and 61b by air-tubes 65. As shown in Figure 7, air-tubes 65 are covered on the side of tubing 60, towards the leg, by another material 66 attached to tubing 60, for example by gluing. The leg 1 is thus prevented from being in direct contact with air-tubes 65.

As shown in Figure 8, tubing 70 comprises a discontinuous surface including see-through openings 73 and large openings 74, covering an area from the upper part of the leg 1 to the ankle. Tubing 70 is partially tight-fitting on the upper section 70a, loose-fitting in the middle section 70b and partially tight-fitting in the lower section 70c. The tubing 70 in the upper section 70a has two loose-fitting portions and one tight-fitting portion. The upper part 71 of the upper section is loose-fitting and is attached to a suitable part of the body other than the leg by attachment means 37. The tubing has two tight-fitting elastic strips 76 and 75 situated respectively in the middle part of the upper section 70a connecting the upper part 71 to the remainder and on the lower edge 77 of the lower section 70c. The upper terminal edge 72 is undulating and the lower terminal edge 77 is on the strip 75. The see-through openings 73 being of

small size do not hinder the movement of the knee of the wearer, while ventilating the tubing; large openings 74 are located on the rear of the tubing 70.

Figure 9 shows two different tubings 150 and 160 worn simultaneously on respective legs. Tubing 150 is partially loose-fitting at the upper section 150a and loose-fitting at the middle and lower sections 150b and 150c. The lower part of the upper section is provided with an elastic strip 152 supporting the tubing 150 on the leg of the wearer. The upper edge 154 is uneven, consisting of two lines 154a and 154b each one of which is at an angle to the transverse section of the wearer's leg. The lower edge 155 comprises fringes 156. Tubing 160 comprises a discontinuous surface including large openings covering an area from below the highest part of the inner side of the leg to the area of the ankle. Edge 161 at the upper end of tubing 160 is nonparallel to the transverse section of the wearer's leg. Tubing 160 is partially loose-fitting on the upper section 160a and partially tight-fitting in the region of an elastic string 163. Middle and lower sections 160b and 160c of tubing 160 are loose-fitting. Chains 162 fasten together materials 97a and 97b leaving large openings between them. A rigid metal plate 164 is formed with eyes 165 by which cords 166 attach it to the edges of a surrounding rectangular recess in the lower edge of the lower section 160c.

The article of dress shown in Figure 10 differs from those so far described in that it consists of a first piece and a second piece, said pieces constituting two different articles of dress, a tubing 100 and a dress 108, the latter having a plurality of permanent folds 109. Each of the said tubing 100 and the said dress 108 is separately attached to a suitable part of a body and is separate from the other. The tubing 100 may be replaced by any of the previously described embodiments. In this embodiment the tubing 100 covers an area from about the ischium down to about the ankle. The tubing 100 is fitted to the leg by means of tight-fitting elastic strip 101 and a tight-fitting inflatable air pocket 105 provided with an air passage 107a and air valve 107b, with loose-fitting portions 100a between the top edge 98 and the strip 101, 100b between the strip 101 and the pocket 105 and 100c between the pocket 105 and the bottom edge 99. There is a greater length of loose-fitting portions than tight-fitting portions. Elastic strip 101 and the air-pocket 105 are placed at the upper and lower ends of the middle section 100b of tubing 100. In the upper section 100a is a built-in pocket 102, and in the middle section 100b is a plurality of openings 104. The extreme lower part of tubing 100 is partly turned inside out to show a lining 106. The upper and lower sections 100a and 100c are at

least 2.5 cm. long.

The dress 108 covers at least a portion of the torso and a substantial portion of only one leg leaving the other leg exposed, this other leg being covered by the tubing 100.

As shown in Figure 11, the article of dress also consists of a first piece and a second piece. The first piece is the tubing 110 fitted by means of elastic strip 111, allowing it to be partially loose-fitting in the upper section 110a and loose-fitting in the middle section 110b and lower section 110c. In the upper section is a built-in pocket 112 and in the lower section 110c and partly in the middle section 110b are longitudinal spaced apart pieces of material 114a, 114b, 114c, 114d, 114e, etc. Said spaced apart pieces of material are connected at both ends by ribbon like material 113a and 113b. The second piece of the article of dress is a dress 108. The tubing 110 is shown in combination with a dress 108, the latter having a plurality of permanent folds 109.

Claims

1. An article of dress for use as a decorative leg covering for a single leg, said article being tubing of decorative light-weight material and capable of being worn as a single unit covering only one leg,
 - (a) said article extending when worn by the wearer from above the knee to below the knee; and
 - (b) said article having upper (13, 41, 54, 66, 71, 98, 154b, 161) and lower (15, 48, 58, 67, 77, 99, 155, 164) terminal edges and supporting means spaced therefrom comprising at least one tight-fitting attachment portion (14, 20b, 31, 46a, 51b, 61a, 76, 101, 152, 163) for engaging a part of the leg of the wearer for supporting the article thereon; characterized in that said article has a loose-fitting portion (16, 20a, 30a, 40a, 50a, 62, 72, 100a, 110a, 150a, 160a) at said upper edge adjacent said tight-fitting attachment portion, said loose-fitting portion extending between said tight-fitting portion and said upper edge and being positioned above said tight-fitting attachment portion when worn by the wearer.
2. An article of dress according to claim 1, having two loose-fitting portions, said article having a second loose-fitting portion (10b, 20c, 33, 40b, 50c, 60b, 100b, 110b) intermediate said tight-fitting attachment portion and said lower edge.
3. An article of dress according to claim 1, said article having three loose fitting-portions (16, 10b, 10c or 40a, 40b, 40c or 100a, 100b, 100c) and comprising at least first and second spaced apart tight-fitting attachment portions (14, 18a or 46a, 46b or 101, 105) spaced from the upper and lower terminal edges said article having a first loose-fitting portion (16, 40a, 100a) extending between said first tight-fitting portion (14, 46a, 101) and said upper edge, said article having a second loose-fitting portion (10c, 40c, 100c) extending between said second tight-fitting portion (18a, 46b, 105) and said lower edge, said article having a third loose-fitting portion (10b, 40b, 100b) extending between said first and second tight-fitting attachment portions.
4. An article of dress according to claim 1, said article having an upper section (10a, 100a) adjacent said upper terminal edge (13, 98), a lower section (10c, 100c) adjacent said lower terminal edge (15, 99), and a middle section (10b, 100b) intermediate said upper and lower sections, at least two of said sections each having at least one tight-fitting portion and at least one loose-fitting portion.
5. An article of dress for use as a decorative leg covering for a single leg, said article being tubing of decorative lightweight material and capable of being worn as a single unit covering only one leg.
 - (a) said article extending when worn by a wearer from above the knee to below the knee; and
 - (b) said article having upper and lower terminal edges (13, 15 or 72, 77) at at least one of which there is a tight fitting portion (18b, 75, 113b); characterized in that said article has at least one tight-fitting portion (18a, 76, 113a) intermediate the upper and lower terminal edges.
6. An article as claimed in claim 5 wherein the article has a tight-fitting portion at both said upper and lower terminal edges (not illustrated).
7. An article according to claim 5, said article comprising at least one tight-fitting attachment portion,
 - (a) said article having supporting means (14, 76, 113a) spaced from upper and lower terminal edges comprising a tight-fitting attachment portion for engaging a part of the leg of the wearer for supporting the article thereon; and
 - (b) said article having a loose-fitting portion (16, 71, 110a) at said upper edge adjacent

said tight-fitting attachment portion, said portion and said upper edge being positioned above said tight-fitting attachment portion when worn by the wearer.

8. An article according to any one of claims 5 and 7, comprising at least one tight-fitting attachment portion (14, 76, 113a) for engaging a part of the leg of a wearer; and having a loose-fitting portion at at least one of the edges (13, 72, 10
9. An article as claimed in any one of claims 1 to 8 comprising at least one opening (52a-52d, 73, 74, 104) in a loose-fitting portion intermediate the upper and lower terminal edges. 15
10. An article of dress according to any one of claims 1 to 9, including at least one inflatable air-pocket (61a, 61b, 105). 20
11. An article according to any one of claims 1 to 10, said article having a length whereby it is capable of extending from the area of the hip to below the knee of the wearer. 25
12. An article according to any one of claims 1 to 10, said first piece having a length whereby it is capable of extending from above the knee to the area of the ankle of the wearer. 30
13. An article according to any one of claims 1 to 10, said first piece having a length whereby it is capable of extending from the area of the hip to the area of the ankle of the wearer. 35
14. An article according to any one of claims 1 to 13 comprising at least two loose-fitting portions (16, 20a, 30a, 40a, 50a, 62, 72, 100a, 110a, 150a, 160a, 10b, 20c, 33, 40b, 50c, 60b, 100b, 110b, 43, 100c) and having a greater portion of the length loose-fitting rather than tight-fitting. 40
15. An article of dress according to any one of claims 1 to 14, comprising a plurality of longitudinal, spaced apart strips of material (31a - 31f, 114a - 114e). 45
16. An article of dress comprising a first piece and a second piece, the first piece comprising an article as claimed in any one of claims 1 to 15, and said second piece (108) for covering at least a portion of the torso of the wearer in the region of the abdomen and hips and a substantial portion of only one leg of a wearer, leaving the other leg exposed, whereby said first piece can be viewed when worn on the other leg of the wearer. 50
55

Patentansprüche

1. Bekleidungsartikel zur Verwendung als dekorative Beinbedeckung für ein einzelnes Bein, wobei besagter Artikel aus dekorativem, leichtem Röhrenmaterial besteht, und als einzelne nur ein Bein bedeckende Einheit getragen werden kann,
- a) wobei besagter Artikel sich beim Tragen durch den Tragenden von oberhalb bis unterhalb des Knies erstreckt, und
- b) wobei besagter Artikel obere (13, 41, 54, 66, 71, 98, 154b, 161) und untere (15, 48, 58, 67, 77, 99, 155, 164) Abschlussborten und Stützmittel mit Abstand davon angeordnet besitzt, die aus mindestens einem enganliegenden Befestigungsteil (14, 20b, 31, 46a, 51b, 61a, 76, 101, 152, 163) bestehen, um einen Teil des Beines des Trägers zu umgeben, um den Artikel darauf zu stützen; dadurch gekennzeichnet, dass besagter Artikel einen locker sitzenden Teil (16, 20a, 30a, 40a, 50a, 62, 72, 100a, 110a, 150a, 160a) an besagter oberer Borte, angrenzend an besagten enganliegenden Befestigungsteil, hat, wobei besagter locker sitzender Teil sich zwischen besagtem enganliegendem Teil und besagter oberer Borte erstreckt und beim Tragen durch den Tragenden oberhalb des enganliegenden Befestigungsteiles liegt.
2. Bekleidungsartikel nach Anspruch 1, mit zwei locker sitzenden Teilen, wobei besagter Artikel einen zweiten locker sitzenden Teil (10b, 20c, 33, 40b, 50c, 60b, 100b, 110b) zwischen besagtem enganliegendem Befestigungsteil und besagter unterer Borte aufweist.
3. Bekleidungsartikel nach Anspruch 1, wobei besagter Artikel drei locker sitzende Teile (16, 10b, 10c oder 40a, 40b, 40c oder 100a, 100b, 100c) hat und mindestens einen ersten und einen zweiten mit Abstand angeordneten, enganliegenden Befestigungsteil (14, 18a or 46a, 46b or 101, 105), mit Abstand von den oberen und unteren Abschlussborten angeordnet aufweist, wobei besagter Artikel einen ersten locker sitzenden Teil (16, 40a, 100a) zwischen besagtem erstem enganliegendem Teil (14, 46a, 101) und besagter oberer Borte aufweist, wobei besagter Artikel einen zweiten locker sitzenden Teil (10c, 40c, 100c) zwischen besagtem zweitem enganliegendem Teil (18a, 46b, 105) und der unteren Borte aufweist, und wobei besagter Artikel einen dritten locker sitzenden Teil (10b, 40b, 100b) zwischen besagten ersten und zweiten enganliegenden Befestigungsteilen aufweist.

4. Bekleidungsartikel nach Anspruch 1, wobei besagter Artikel einen oberen Teil (10a, 100a) angrenzend an besagte obere Abschlussborte (13, 98), einen unteren Teil (10c, 100c) angrenzend an besagte untere Abschlussborte (15, 99), und einen mittleren Teil (10b, 100b) zwischen besagten oberen und unteren Teilen hat, wobei mindestens zwei dieser besagten Teile je mindestens einen enganliegenden Teil und mindestens einen locker sitzenden Teil aufweisen. 5
5. Bekleidungsartikel zum Gebrauch als dekorative Beinbedeckung für ein einzelnes Bein, wobei besagter Artikel aus dekorativem leichtem Material in Röhrenform besteht und als-Einzelinheit getragen werden kann, die nur ein Bein bedeckt, 15
- a) wobei besagter Artikel sich beim Tragen durch den Tragenden von oberhalb des Knies bis unterhalb des Knies erstreckt, und 20
- b) wobei besagter Artikel obere und untere Abschlussborten (13, 15 oder 72, 77) aufweist und mindestens einer davon einen enganliegenden Teil (18b, 75, 113b) aufweist, 25
- dadurch gekennzeichnet, dass besagter Artikel mindestens einen enganliegenden Teil (18a, 76, 113a) zwischen den oberen und unteren Abschlussborten aufweist. 30
6. Artikel nach Anspruch 5, wobei der Artikel einen enganliegenden Teil an beiden besagten oberen und unteren Abschlussborten (nicht gezeigt) aufweist. 35
7. Artikel nach Anspruch 5, wobei besagter Artikel aus mindestens einem enganliegenden Befestigungsteil besteht, 40
- a) wobei besagter Artikel Stützmittel (14, 76, 113a) mit Abstand angebracht von den oberen und unteren Abschlussborten, bestehend aus einem enganliegendem Befestigungsteil, um einen Teil des Beines des Trägers zu umgeben, um den Artikel darauf zu stützen, aufweist, und 45
- b) wobei besagter Artikel einen locker sitzenden Teil (16, 71, 110a) an besagter oberer Borte angrenzend an besagten enganliegenden Befestigungsteil aufweist, wobei besagter Teil und besagte obere Borte beim Tragen durch den Tragenden oberhalb des besagten enganliegenden Befestigungsteiles angebracht sind. 50
8. Bekleidungsartikel nach irgendeinem der Ansprüche 5 bis 7, bestehend aus mindestens einem enganliegenden Befestigungsteil (14, 76, 113a), um einen Teil des Beines des Trägers zu umgeben; und mit einem locker sitzenden Teil an mindestens einer der Borten (13, 72). 55
9. Artikel nach irgendeinem der Ansprüche 1 bis 8 beinhaltend mindestens eine Öffnung (52a-52d), 73, 74, 104) in einem locker sitzenden Teil zwischen den oberen und unteren Abschlussborten.
10. Bekleidungsartikel nach irgendeinem der Ansprüche 1 bis 9, welcher mindestens eine aufblasbare Lufttasche enthält (61a, 61b, 105).
11. Artikel nach irgendeinem der Ansprüche 1 bis 10, wobei besagter Artikel eine Länge hat, welche ihn befähigt, sich von der Hüftgegend bis unterhalb des Knies des Trägers zu erstrecken.
12. Artikel nach irgendeinem der Ansprüche 1 bis 10, wobei besagter erster Teil eine Länge hat, welche ihn befähigt, sich von oberhalb des Knies bis zur Knöchelgegend des Trägers zu erstrecken.
13. Artikel nach irgendeinem der Ansprüche 1 bis 10, wobei besagter erster Teil eine Länge hat, welche ihn befähigt, sich von der Hüftgegend bis zur Knöchelgegend des Trägers zu erstrecken.
14. Artikel gemäss irgendeinem der Ansprüche 1 bis 13, beinhaltend mindestens zwei locker sitzende Teile (16, 20a, 30a, 40a, 50a, 62, 72, 100a, 110a, 150a, 160a, 10b, 20c, 33, 40b, 50c, 60b, 100b, 110b, 43, 100c), wobei ein grösserer Teil der Länge eher locker sitzend als enganliegend ist.
15. Bekleidungsartikel nach irgendeinem der Ansprüche 1 bis 14, eine grosse Anzahl von der Länge nach und mit Abstand zueinander angeordnete Stoffstreifen (31a-31f, 114a-114e) beinhaltend.
16. Bekleidungsartikel beinhaltend einen ersten Teil und einen zweiten Teil, wobei der erste Teil aus einem Artikel wie in irgendeinem der Ansprüche 1 bis 15 beansprucht besteht, und besagter zweiter Teil (108) mindestens einen Teil des Rumpfs des Trägers in der Gegend des Bauches und der Hüften und einen wesentlichen Teil eines einzelnen Beines des Trägers bedeckt, das andere Bein unbedeckt lassend, wobei besagter erster Teil sichtbar ist, wenn er am anderen Bein des Trägers getra-

gen wird.

Revendications

1. Article de confection destiné à être utilisé comme couverture de jambe décorative pour une seule jambe, ledit article étant constitué d'un canon de matériau décoratif léger et pouvant être porté comme un élément unique recouvrant une jambe, 5
- (a) ledit article s'étendant lorsqu'il est porté par l'usager depuis au-dessus du genou jusqu'à au-dessous de genou; et 10
- (b) ledit article comprenant des bords extrêmes supérieurs (13, 41, 54, 66, 71, 98, 154b, 161) et inférieurs (15, 48, 58, 67, 77, 99, 155, 164) et des moyens de maintien séparés desdits bords et comprenant au moins une portion de fixation serrée (14, 20b, 31, 46a, 51b, 61a, 76, 101, 152, 163) pour coopérer avec une partie de la jambe de l'usager pour maintenir ladite pièce sur celle-ci. 15
- caractérisé en ce que ledit article a une portion ample (16, 20a, 30a, 40a, 50a, 62, 72, 100a, 110a, 150a, 160a) située audit bord supérieur, adjacente à ladite portion de fixation serrée, ladite portion ample s'étendant entre ladite portion serrée et ledit bord supérieur et se trouvant au-dessus de la portion de fixation serrée lorsqu'il est porté par l'usager. 20
2. Article de confection selon la revendication 1, comportant deux portions amples, ledit article comportant une deuxième portion ample (10b, 20c, 33, 40b, 50c, 60b, 100b, 110b) située entre la portion de fixation serrée et ledit bord inférieur. 25
3. Article de confection selon la revendication 1, ledit article comprenant trois portions amples (16, 10b, 10c ou 40a, 40b, 40c ou 100a, 100b, 100c) et comprenant au moins une première et une deuxième portion de fixation serrée espacées l'une de l'autre (14, 18a ou 46a, 46b ou 101, 105) à distance des bords extrêmes supérieur et inférieur, ledit article ayant une première portion ample (16, 40a, 100a) s'étendant entre ladite première portion serrée (14, 46a, 101) et ledit bord supérieur, ledit article comportant une deuxième portion ample (10c, 40c, 100c) s'étendant entre ladite deuxième portion serrée (18a, 46b, 105) et ledit bord inférieur, ledit article comportant une troisième portion ample (10b, 40b, 100b) s'étendant entre ladite première et ladite deuxième portion de fixation serrée. 30
4. Article de confection selon la revendication 1, ledit article comportant une partie supérieure (10a, 100a) adjacent audit bord extrême supérieur (13, 98), une partie inférieure (10c, 100c) adjacent audit bord extrême inférieur (15, 99), et une partie médiane (10b, 100b) située entre ladite partie supérieure et ladite partie inférieure, au moins deux desdites parties ayant au moins une portion serrée et au moins une portion ample. 35
5. Article de confection destiné à être utilisé comme couverture de jambe décorative pour une seule jambe, ledit article étant constitué d'un canon de matériau léger décoratif et pouvant être porté comme un élément unique recouvrant une seule jambe. 40
- (a) ledit article s'étendant lorsqu'il est porté par un usager depuis au-dessus du genou jusqu'à au-dessous du genou; et
- (b) ledit article comportant des bords extrêmes supérieur et inférieur (13, 15 ou 72, 77), au niveau d'un desquels est située au moins une portion serrée (18b, 75, 113b); caractérisé en ce que ledit article comporte au moins une portion serrée (18a, 76, 113a) située entre lesdits bords extrêmes supérieur et inférieur. 45
6. Article de confection selon la revendication 5 comportant une portion serrée à chacun des bords extrêmes supérieur et inférieur (non représenté). 50
7. Article de confection selon la revendication 5, ledit article comprenant au moins une portion de fixation serrée, 55
- (a) ledit article comportant des moyens de maintien (14, 76, 113a) espacés des bords extrêmes supérieur et inférieur et comprenant une portion de fixation serrée destinée à coopérer avec une partie de la jambe de l'usager pour maintenir la pièce sur celle-ci; et
- (b) ledit article comportant une portion ample (16, 71, 110a) au niveau dudit bord supérieur adjacent à la portion de fixation serrée, ladite portion et ledit bord supérieur étant disposés au-dessus de la portion de fixation serrée lorsqu'il est porté par l'usager.
8. Article de confection selon l'une des revendications 5 et 7, comportant au moins une portion de fixation serrée (14, 76, 113a) destinée à coopérer avec une partie de la jambe de l'usager; et comprenant une partie ample à au moins au niveau d'un des bords (13, 72).

9. Article de confection selon l'une des revendications 1 à 8 comprenant au moins une ouverture (52a-52d, 73, 74, 104) située dans une portion ample située entre les bords extrêmes supérieur et inférieur. 5
10. Article de confection selon l'une des revendications 1 à 9, comprenant au moins un compartiment à air gonflable (61a, 61b, 105). 10
11. Article de confection selon l'une des revendications 1 à 10, ledit article ayant une longueur lui permettant de s'étendre depuis la région de la hanche jusqu'à au-dessous du genou de l'utilisateur. 15
12. Article de confection selon l'une des revendications 1 à 10, ledit premier élément ayant une longueur lui permettant de s'étendre depuis au-dessus du genou jusqu'à la région de la cheville de l'utilisateur. 20
13. Article de confection selon l'une des revendications 1 à 10, ledit premier élément ayant une longueur lui permettant de s'étendre depuis la région de la hanche jusqu'à la région de la cheville de l'utilisateur. 25
14. Article de confection selon l'une des revendications 1 à 13 comprenant au moins deux portions amples (16, 20a, 30a, 40a, 50a, 62, 72, 100a, 110a, 150a, 160a, 10b, 20c, 33, 40b, 50c, 60b, 100b, 110b, 43, 100c) et étant ample sur la jleur partie de sa longueur. 30
35
15. Article de confection selon l'une des revendications 1 à 14, comprenant une pluralité de bandes longitudinales, espacées les unes des autres (31a - 31f, 114a - 114e). 40
16. Article de confection comprenant un premier élément et un second élément, ledit premier élément étant constitué par un article de confection selon l'une des revendications 1 à 15, et ledit deuxième élément (108) recouvrant au moins une partie du torse de l'utilisateur dans la région de l'abdomen et des hanches et une partie substantielle d'une seule des jambes de l'utilisateur, laissant l'autre jambe exposée, de façon à ce que ledit premier élément soit visible lorsqu'il est porté sur l'autre jambe de l'utilisateur. 45
50

55

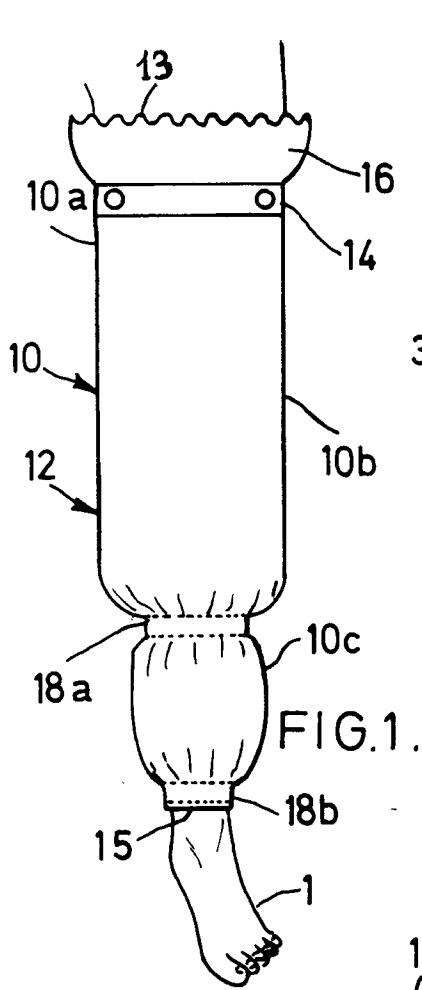

FIG. 1.

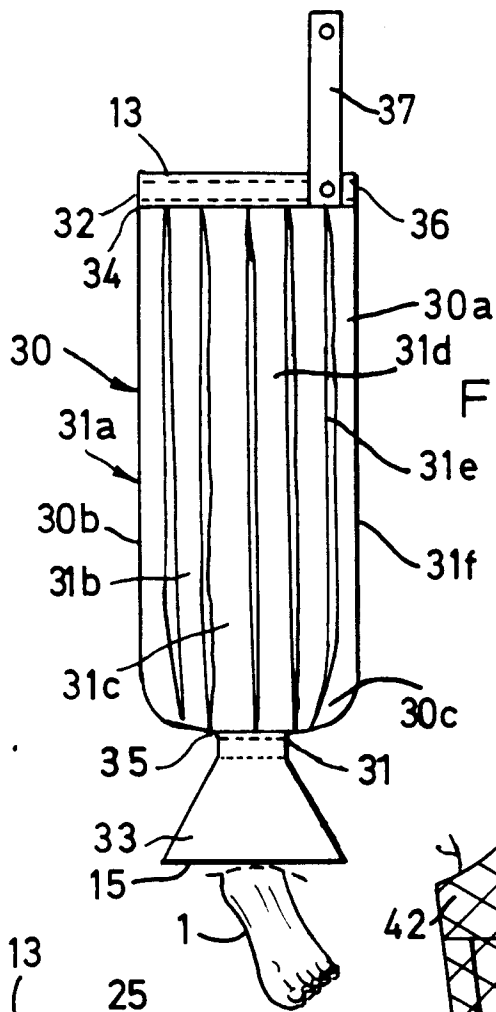

FIG. 3.

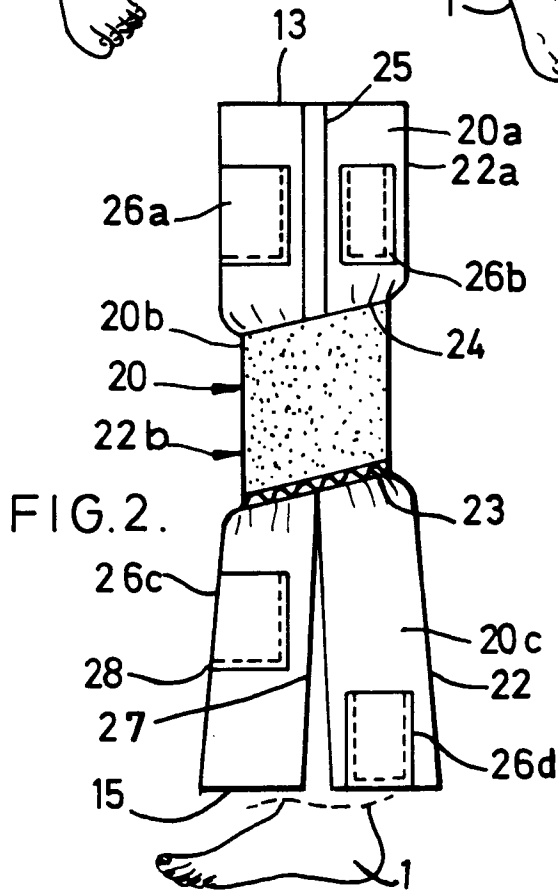

FIG. 2.

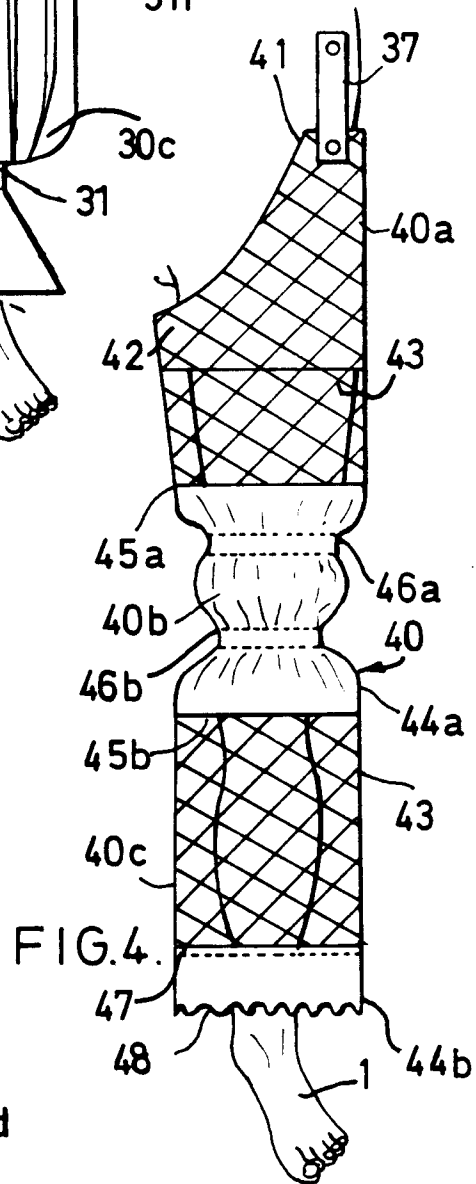

FIG. 4.

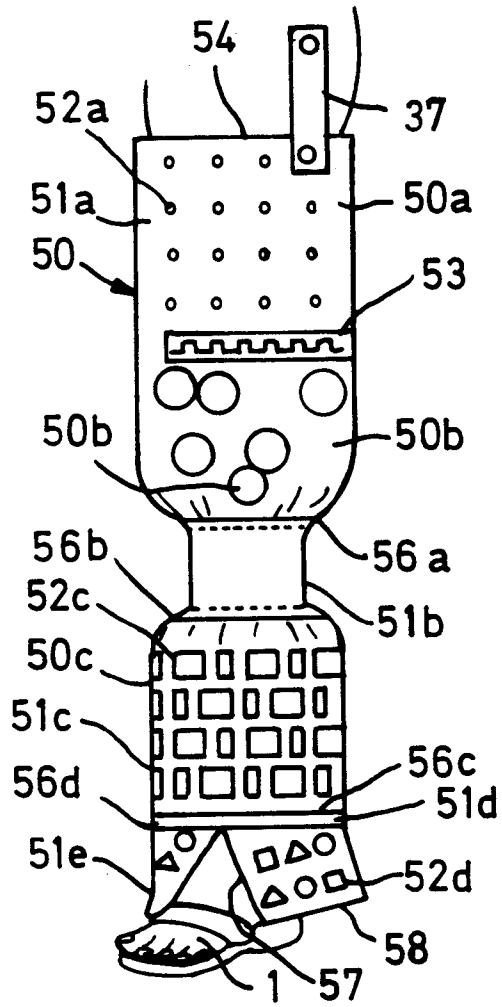

FIG. 5.

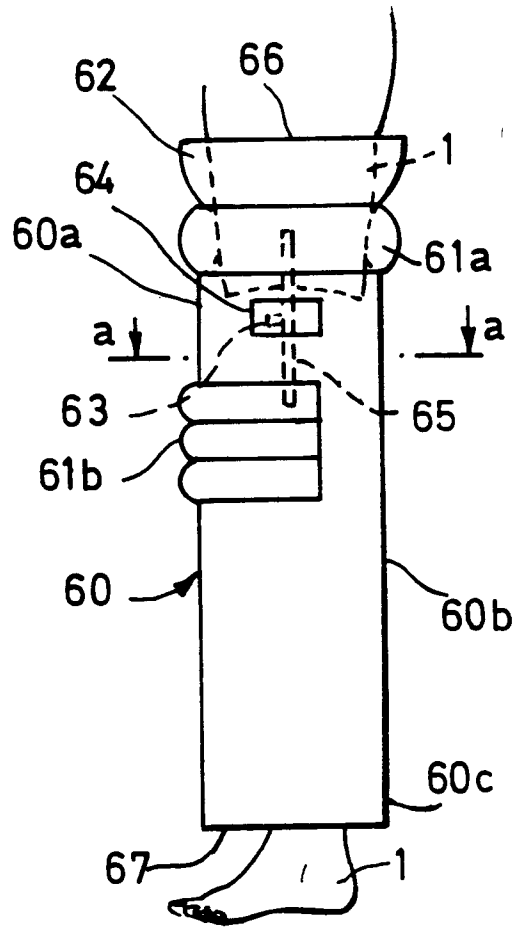

FIG. 6.

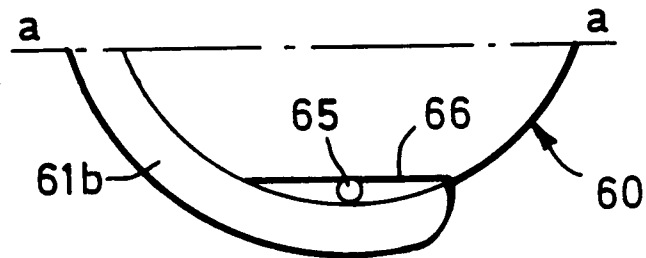

FIG. 7.

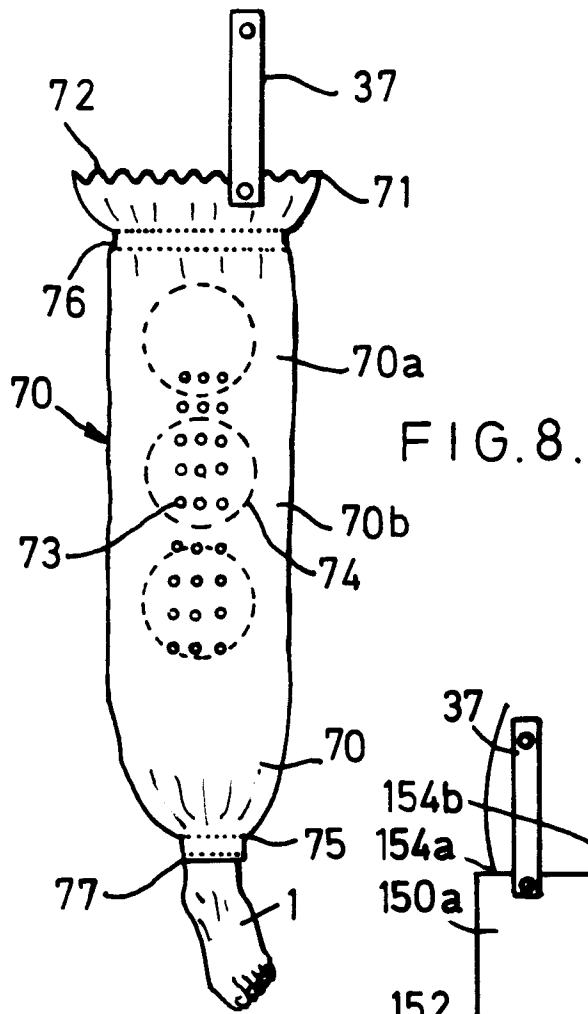

FIG. 8.

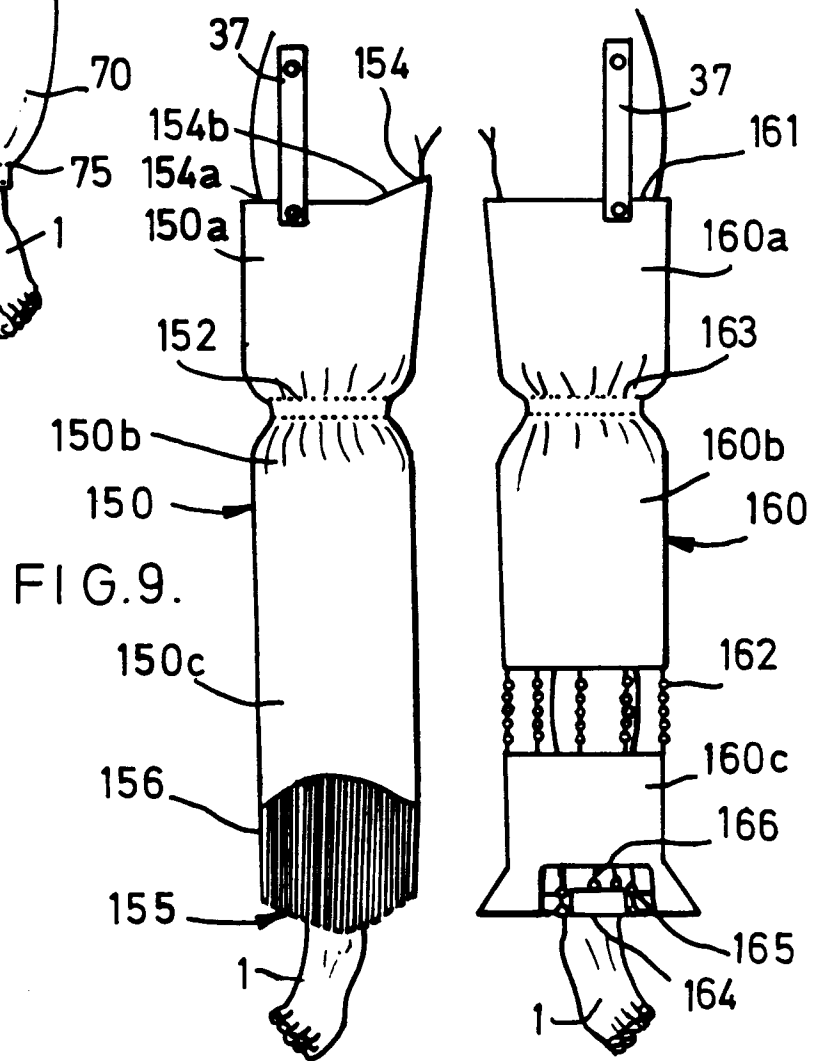

FIG. 9.

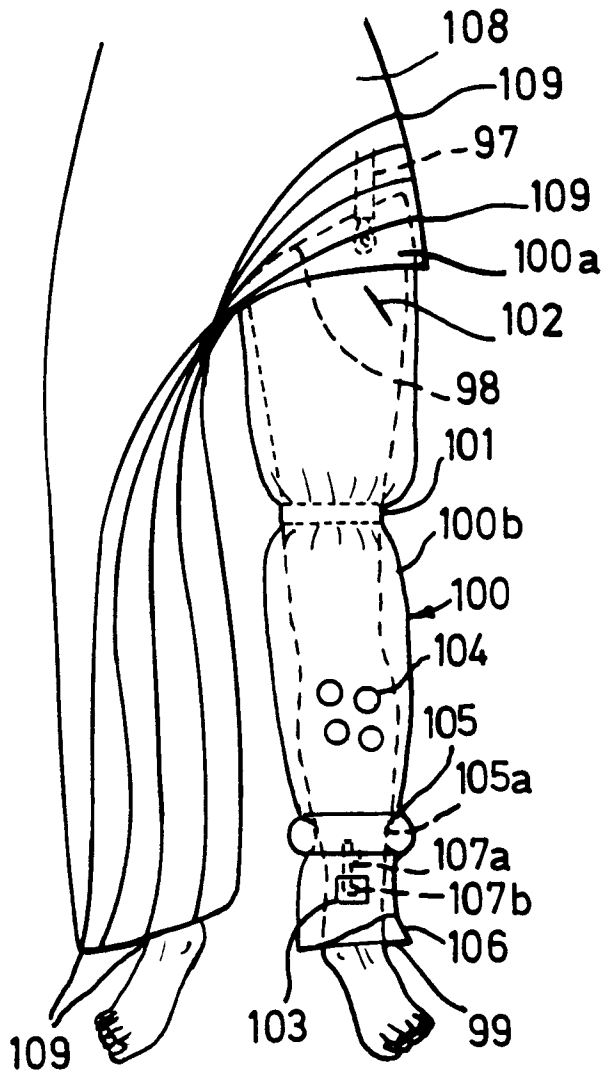

FIG. 10.

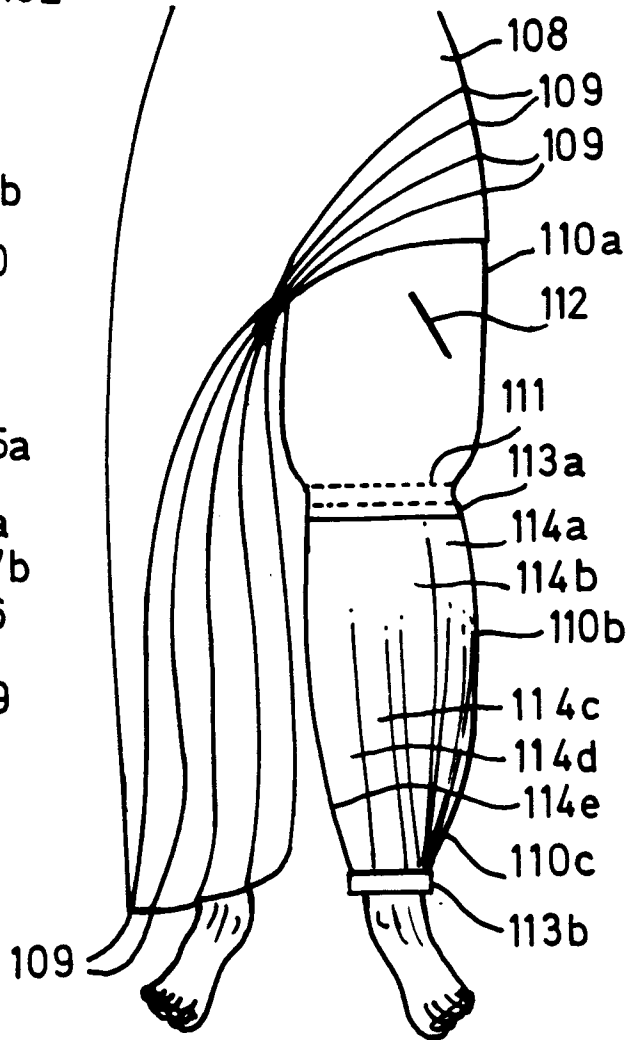

FIG. 11.