

**EUROPEAN PATENT APPLICATION**

Application number: 88103375.7

Int. Cl.4: **B65C 9/22 , B05C 11/02**

Date of filing: 04.03.88

Date of publication of application:  
06.09.89 Bulletin 89/36

Applicant: **RITRAMA SPA**  
Via della Guerrina 108  
I-20052 Monza (Milan)(IT)

Designated Contracting States:  
**AT BE DE ES FR GB GR IT LU NL SE**

Inventor: **Mosca Tenna, Giovanni, Dr. Ing.**  
Elektrastrasse 38  
D-8000 München 81(DE)

Representative: **Pozzoli, Giuliano et al**  
e/o **ENGIMPEX S.A. Industrial Property**  
Services Dept. P.O. Box 12  
CH-6924 Lugano-Sorengo(CH)

**Hydrostatic dosing roller with visualization of the displacement by means of controlling hydrostatic pad for millesimal dosing.**

The cylinder (8) of the dosing roller rotates on eight hydrostatic pads (PR1) which are fed by eight fixed laminar resistots (R1), to assure absolute rotation and stiffness accuracy.

The adjustment of the distance of the dosing roller is performed by eight hydrostatic pads (PR2), four of which (PR2') are fed by four fixed laminar resistors (R2) and four (PR2'') are fed by two valves (V1, V2) which control the oil flow and allow an absolutely accurate millesimal displacement.

The visualization of the displacement is performed by two hydrostatic controlling pads (PC), which are fed by fixed laminar resistors (R3), which allow an accurate measurement by the survey of the pressure variation. It is possible then to vary the position of the support shaft (9) without any slack and consequently the distance of the dosing roller from the coating roller, providing the desired dosing with absolute accuracy. The tolerances of the basic weight of the coated products are then drastically reduced in comparison to the traditional machines, with a remarkable saving of the production costs and an improvement of the quality of the finished products (figure 2).

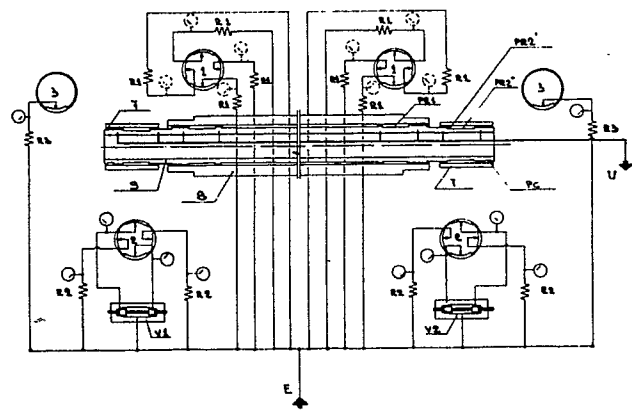

FIG. 2.

**EP 0 330 720 A1**

## HYDROSTATIC DOSING ROLLER WITH VISUALIZATION OF THE DISPLACEMENT BY MEANS OF CONTROLLING HYDROSTATIC PAD FOR MILLESIMAL DOSING

The present invention refers to a dosing roller for coating machines, with hydrostatic pads for the rotation hydrostatic pads for adjustment and hydrostatic pad for control of the visualized displacement for millesimal dosing.

The novelty of the invention consists essentially in providing a dosing roller for coating machines with a number of hydrostatic pads. A set of hydrostatic pads serve as rolling bearing, which by the stiffness of its system eliminates all the mechanical slacks; another set of hydrostatic pads serves to adjust the displacement of its axis with reference to the axis of its supports; finally two hydrostatic pads serve to check the occurred displacement.

Then the novelty consists essentially in the fact that by the rotation of the dosing cylinder on high-pressure hydrostatic pads and by the introduction of a valve which controls the oil flow to the pads both the cylinder displacement and its absolutely perfect rotation can be obtained.

Moreover using a further control pad the displacement realized by the hydraulic valve can be visualized. It is well-known that the machines for the coating of adhesives on paper, PVC, polypropylene reels consist of two or more rotating rollers, whose distance controls the dosing of the adhesive. At the present state-of-the-art the dosing rollers are put in rotation on high-precision mechanical bearings. The manufacturing accuracy of the roller is very high too, because any rolling irregularity induces an error on the basic weight of the final product.

The distance between the dosing roller and the roller which supports the material (or the feeding roller in the case of an indirect coating machine) defines the quantity of coated product. For this reason the dosing roller is provided with mechanical approach systems (levers or slides) which are manufactured with the best possible accuracy.

The limitations of accuracy and stiffness of these solutions, even with a very accurate manufacturing of the pieces, are remarkable because of the dimensions of the cylinders and of the weights into play. Even in the case of use of electronic devices for the reading of the displacements, the best achievable accuracy is 10/20 micron with basic weight errors of 5/10 g/m<sup>2</sup> of adhesive.

Beside a remarkable waste of energy in the drying of the coated product, such errors of basic weight cause problems mainly during the work on punching and printing automatic machines, particularly in the case of self-adhesive materials like rigid and plastic films and self-adhesive labels.

The applicant doesn't know any kind of coating dosing roller for adhesive, which is provided with pads for the visualized hydrostatic adjustment and which has the features of the subject one.

5 To prevent the said troubles the present invention aims to obtain:

- absolute accuracy in the rotation of the dosing roller
- very high stiffness of the system, exceeding 500 kg/micron and up to 1000 kg/micron approx.
- visualized infinitesimal adjustment of the displacement of the roller
- positive elimination of any error of basic weight coming from mechanical factors.

15 Looking to the stated targets and to the limitations of the existing machines, the capacity of industrial development of the invention appears evident.

20 The originality of the invention consists essentially in the fact that the thickness of the oil meatus and then the position of the roller can be adjusted without the use of devices with mechanical fittings. Exploiting the same principle of hydrostatic reaction and inserting a specific pad, the displacement which is originated by the control valve can be visualized by means of a simple gauge, which indicates the variation of the oil pressure.

25 More precisely the present invention refers to a hydrostatic dosing roller with millesimal dosing for coating machines, which is characterized by the fact that it includes hydrostatic pads for the rotation, hydrostatic support pads for the millesimal adjustment of the displacement of said roller and hydrostatic control pads for the visualization of the even millesimal displacements, to obtain coating with millesimal dosing accuracy.

30 The carrying structure must be built by electric-welded and stabilized rugged metallic structural work, the hydrostatic pads are realized on a thick central shaft in order to avoid any load deformation. The rotating rollers are driven by DC motors in order that the production rate and the adhesive dosing can be varied. The machine is provided with a scraping blade for the cleaning of the adhesive dosing roller and with shoulders to hold the adhesive.

35 The hard-rubberized roller which carries the material is driven by hydraulic cylinders in order to control the pressure on the coating roller; in case of stopping of the system the separation is automatically obtained by means of mechanical cams or by means of manual contrasting precision screws.

40 It must be noted that the quantity of adhesive,

which is laid down on the support, depends both on the rotation speed of the coating roller and on the distance between the surfaces of the dosing roller and of the coating or feeding roller.

According to the invention the dosing roller rotates on eight rolling pads, which are fed by fixed laminar resistors; their design is according to the theory of lubrication of the cylindrical garring pins and to the theory of the hydrodynamic sustentation of the variable-thickness meatus. By the rotation of the dosing roller a stiffness varying from 500 kg/micron up to 1000 kg/micron can be obtained with a perfect rolling.

By realizing eight further pads on the shaft which supports the dosing roller (four of which are fed by fixed resistors and the other four by two valves which control the flow) the position of the supporting shaft can be changed as desired with the required accuracy and without slacks.

We give in the following a detailed description of a preferred form of execution of the invention, with reference to the attached drawings, without depriving of anything the generality of the invention itself.

- The figure 1 shows a perspective view of the coating machine, with the location of the hydrostatic dosing roller.

- The figure 2 shows the hydraulic scheme of connection of the pads of the hydrostatic roller and the hydraulic oil/lubrication flow; inlet E, outlet U.

- The figure 3 shows a longitudinal section of the hydraulic roller

- The figure 4 shows a normal section of the hydrostatic roller which shows the rotation pads PR1 and the line on which they work ( $30^\circ$ ).

- The figure 5 shows a normal section of the hydrostatic roller which shows the pads PR2', PR2'' which are fed by the fixed laminar resistors R2 and by the valves V1 and V2 and the line on which they work ( $30^\circ$ ).

- The figure 6 shows a normal section of the hydrostatic roller which shows the external control pad PC and the line on which it works ( $30^\circ$ ).

With the reference to the coating machine shown in the figure 1:

It can be seen the rubberized roller C which carries the material 4 to the coating roller B.

The quantity of adhesive which is carried (coated) depends on the speed of the coating roller B, on the speed of the dosing roller A and on the distance between their surfaces. For the definition of the thickness 5 of the adhesive and the control of its value it is necessary to be able to adjust with the desired accuracy the distance between the dosing roller A and the coating roller B, through which the adhesive 6 flows.

The accuracy of the distance is mainly obtained by a high stiffness of the system.

The stiffness of the system is obtained by eight rotation pads PR1 of the hydrostatic roller (figures 3 and 4) which are realized on the central shaft 9 and are fed by eight fixed laminar resistors R1 (figures 2 and 4); the stiffness which can be achieved ranges between 500 kg/micron and 1000 kg/micron approx.

For the adjustment of the distance between the dosing roller and the coating roller eight further hydrostatic pads PR2 (figures 3 and 5), which are facing the supporting shaft 7, are realized again on the central shaft 9 (figures 3 and 4); four PR2' are fed by four fixed laminar resistors R2 (figure 2) and the other four PR2'' are fed by two valves V1 and V2 (figure 2), which control the flow.

By means of the valves V1 and V2 it is possible to vary the oil flow and then the thickness of the meatus, moving away and bringing near the dosing roller A and the coating roller B with the highest accuracy.

A very accurate adjustment without slacks can be obtained.

The visualization of the displacements, which are originated by the valves V1 and V2, is possible by means of two controlling hydrostatic pads PC (figures 3 and 6) which are fed by two fixed laminar resistors R3 (figure 2); according to the variation of the thickness of the meatus they signal a pressure variation on an instrument (gauge), giving the immediate knowledge of the reached distance. In our particular case 1 atm signals the displacement of 1 micron.

Because the pressure measurement comes from the average span of the meatus and from a large contact surface (surface of the controlling pads), it results absolutely stable and significant; such measurement can be amplified as desired by the designer according to the working requirements.

With the said stiffness and adjustment conditions coatings with width up to 1.5 m and speed up to 150 m/min can be obtained, with a perfect control of the basic weight and of the superficial density of the distribution of the adhesive.

The above described machine which is the subject of the invention allows to drastically reduce the tolerances of basic weight of the products and indirectly allows in addition a sensible saving of production costs (energy, scrap material and so on).

#### 55 MODE OF OPERATION OF THE COATING MACHINE

With reference to the figure 1:

The machine must be fed continuously with adhesive 6 between the coating roller B and the dosing roller A.

The adhesive has lateral holding shoulders 10 to avoid the overflow.

The quantity of adhesive which lays itself down on the support film depends on the distance between the coating roller B and the dosing roller A. The dosing roller is chromium plated and motorized by a DC motor; it is adjustable to increase or decrease the distance from the coating roller and then to dose the quantity of adhesive on the film; the distance is adjusted acting on the above described valves V1 and V2. The dosing roller is provided with a scraping blade (11) for its continuous cleaning.

The chromium plated and motorized by a DC motor coating roller B rotates in opposite direction with reference to the dosing roller A and to the rubberized roller C.

The rubberized roller C is motorized by a DC motor and it is mounted on levers which are driven by hydraulic cylinders; the hydraulic cylinders allow the adjustment of the pressing of the material on the coating roller and the laying of the adhesive (5) on the film (4).

In order to further adjust the pressing, high-precision micrometric mechanical adjusters (12) are mounted on the levers of the rubberized roller.

With reference to the coating machine which is shown in the figure 1, a layer of adhesive is laid down on the hard-rubberized roller C which carries the adhesive support material 4 (tape which has to become adhesive) by means of the coating roller B; the quantity 5 of adhesive which is laid down on the support 4 depends on the rotation speed of the coating roller B and of the dosing roller A and on the distance between their surfaces.

For the determination of the thickness of the adhesive layer and the control of its value it is necessary to succeed to adjust with the desired accuracy the distance through which the adhesive flows between the dosing roller A and the coating roller B. This accuracy and then the evenness of the basic weight of the adhesive depends also on the stiffness of the cylinder.

Rotating the cylinder 8 of the dosing roller A on eight rolling pads PR1 (figure 4), which are fed by fixed laminar resistors R1, stiffness up to 920/1000 kg/micron approx. and a perfect rolling of the cylinder can be obtained.

Beside it, if eight further rolling pads PR2 (figure 5) are realized on the shaft 9' of the cylinder 8 of the roller A (figure 2) - four of which PR2' are fed by fixed resistors R2 and the other four PR2'' are fed by two valves V1 and V2 which control the flow - it is possible to vary the position of the support shaft as desired and with the desired

accuracy without slacks and then the position of the cylinder of the dosing roller A with reference to the coating roller B.

If two controlling pads PC (figure 6), which are fed by fixed laminar resistors R3, are embodied (figure 2), the displacement which is generated by the control valves V1 and V2 modifies the resistance of the controlling pads and then the internal pressure of the sump. The survey of this pressure by means of a suitable instrument (gauge, electronic gauge and so on) measures also the displacement of the dosing cylinder; in our case 1 atm shows 0.001 mm.

It is possible to obtain under these conditions coatings of width up to 1500 mm at a speed of 150 m/min with a perfect control of the basic weight and of the superficial density of distribution of the adhesive.

## Claims

1) Hydrostatic dosing roller (8) with millesimal dosing for coating machines, which is characterized by the fact that it includes hydrostatic pads (PR1) for the rotation, hydrostatic support pads (PR2) for the millesimal adjustment of the displacement of the said roller and hydrostatic controlling pads (PC) for the visualization of the even millesimal displacement, to obtain coating with millesimal accuracy of dosing.

2) Hydrostatic dosing roller with millesimal dosing for coating machines according to the claim 1, which is characterized by the fact that the rotation is allowed by eight pads (PR1) which are fed by eight fixed laminar resistors (R1); by the fact that the millesimal adjustment of the dosing roller is performed by eight further hydrostatic pads, four of which (PR2') are fed by fixed laminar resistors (R2) and the other four (PR2'') are fed by two valves (V1 and V2) which control the flow in the thickness of the meatus; by the fact that the displacement is visualized by two hydrostatic controlling pads (PC) which are fed by fixed laminar resistors (R3).

3) Hydrostatic dosing roller for coating machines according to the claim 1 or 2, in which the hydrostatic pads acting as bearings for the rotation, the adjustment and the control are realized on a thick central shaft (9) in order to obtain high stiffness and to avoid any load deformation.

4) Hydrostatic dosing roller for coating machines according to the claim 3, in which the hydrostatic support pads allow the millesimal adjustment of the distance between the dosing roller and the coating roller, as desired, with absolute accuracy and without any slack.

5) Hydrostatic dosing roller for coating machines according to any one of the claims 1 to 4, in which the driving of the rollers (A, B, C) is committed to DC motors in order to vary the production rate.

5

6) Use of the hydrostatic dosing roller, according to any one of the claims 1 to 5, in adhesive coating machines for the production of self-adhesive materials, particularly self-adhesive films and self-adhesive labels.

10

15

20

25

30

35

40

45

50

55

5

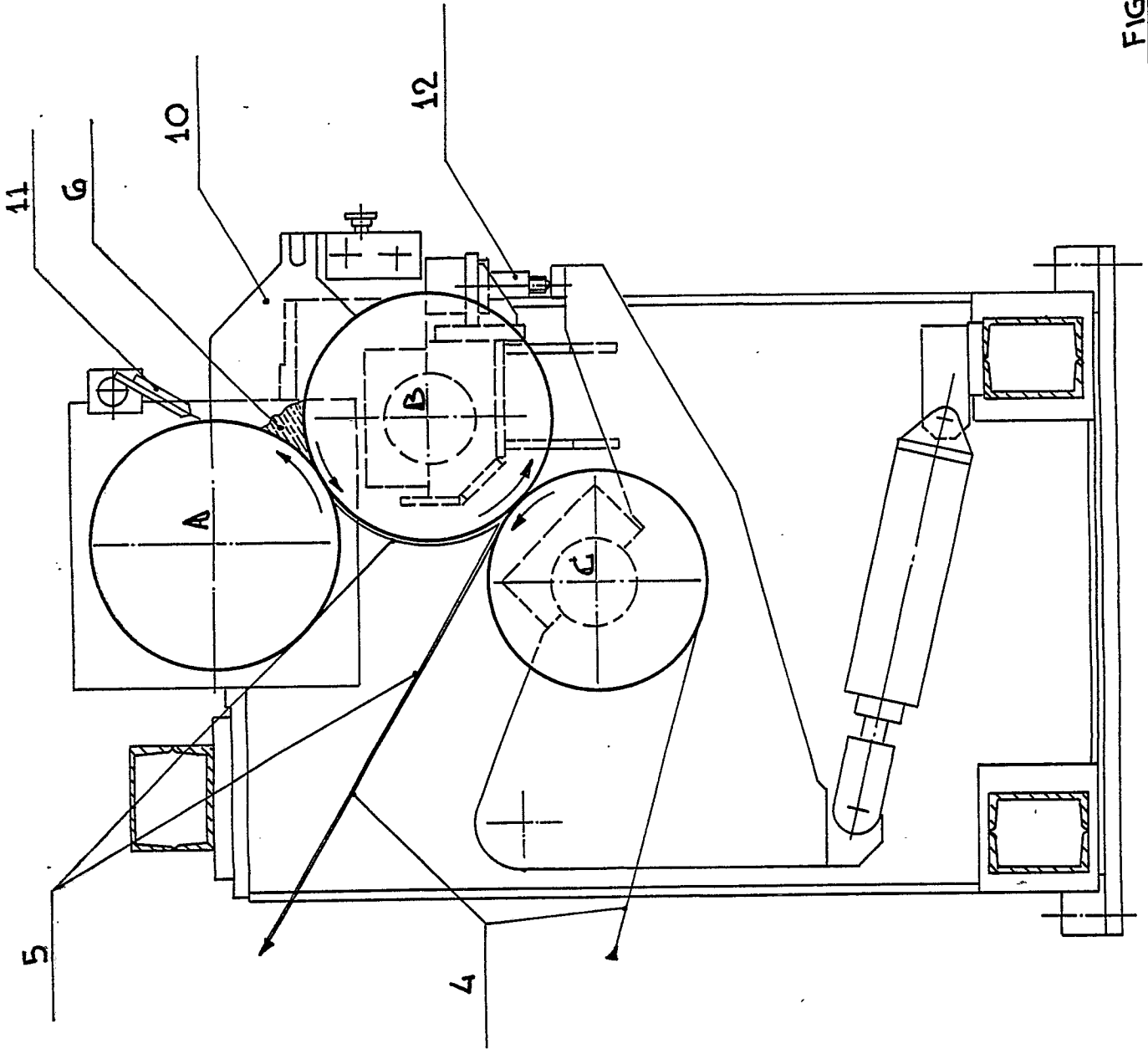
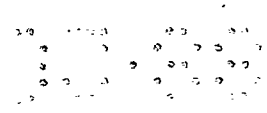

FIG. 1

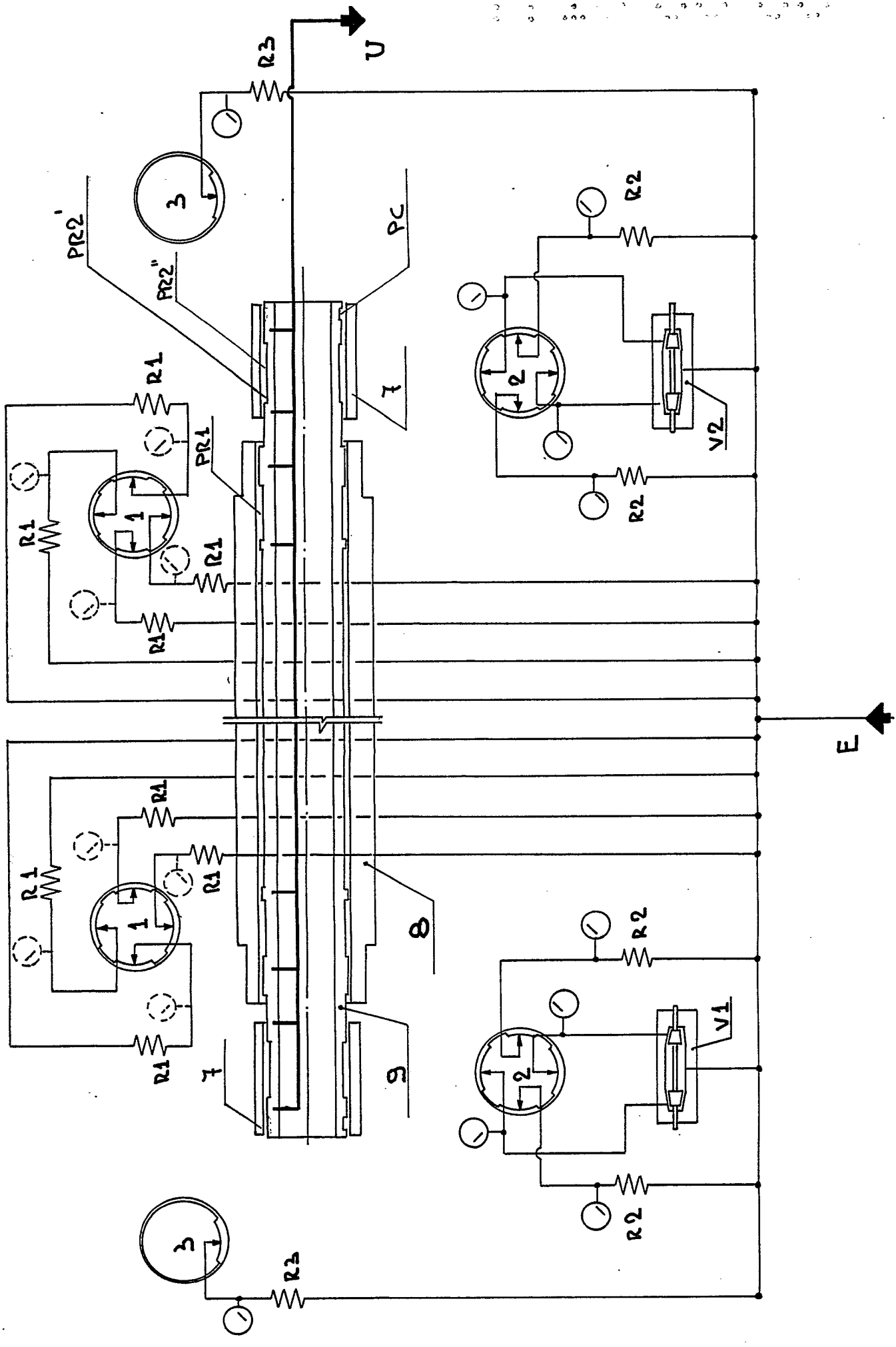
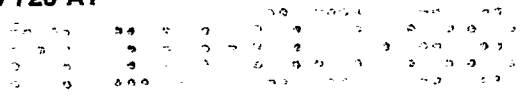

FIG. 2

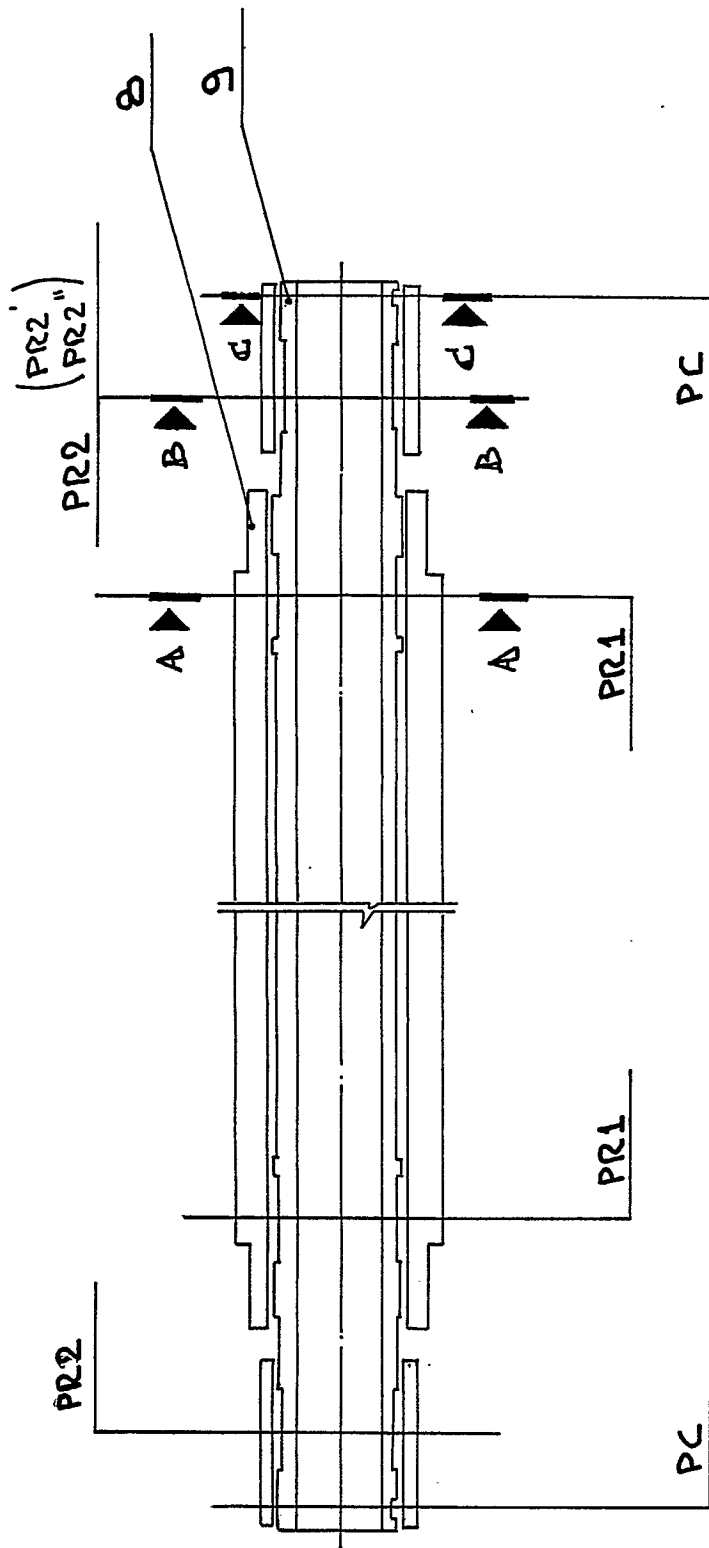
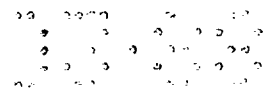
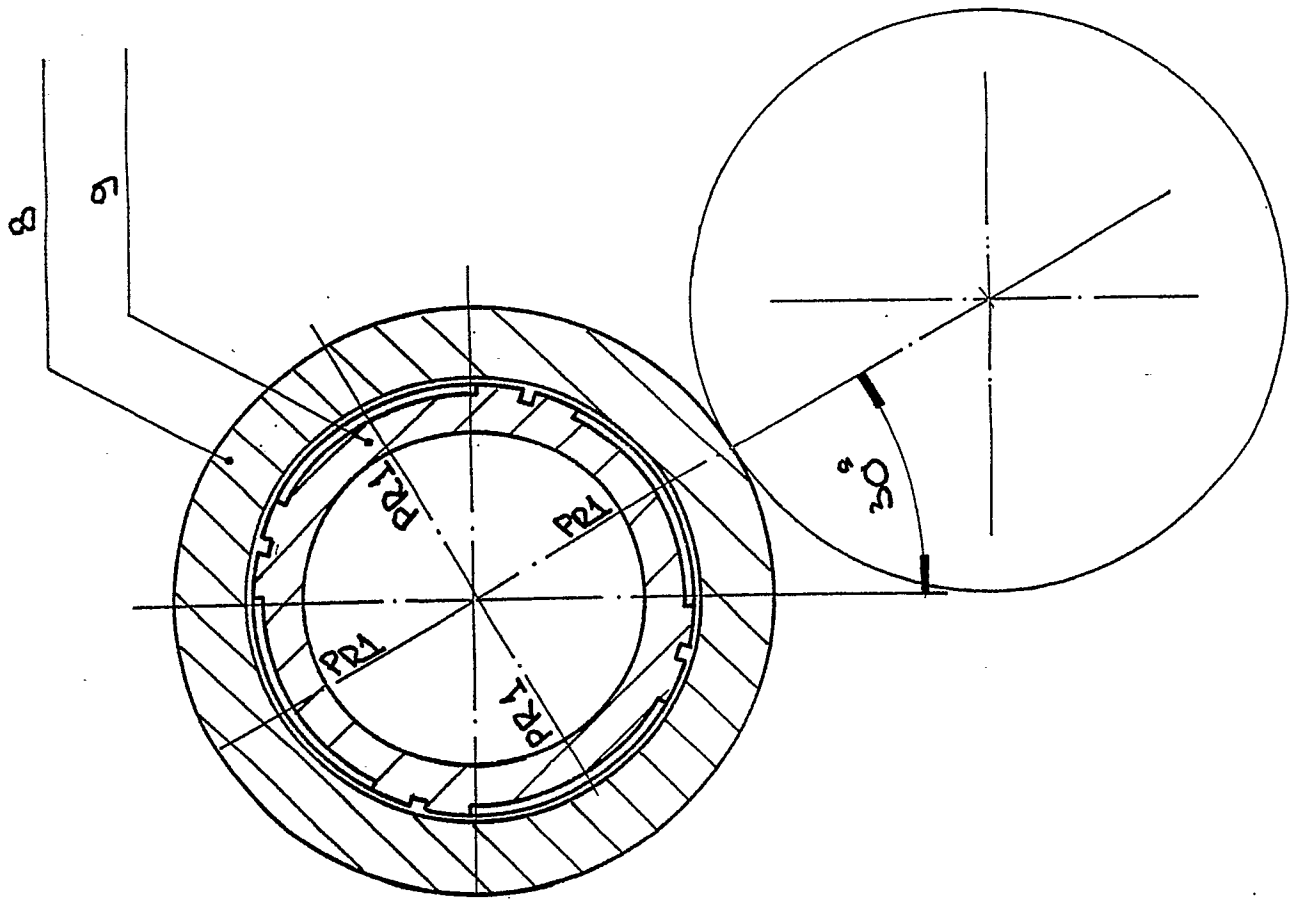
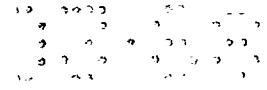

FIG. 3



SEC. A-A

FIG. 4

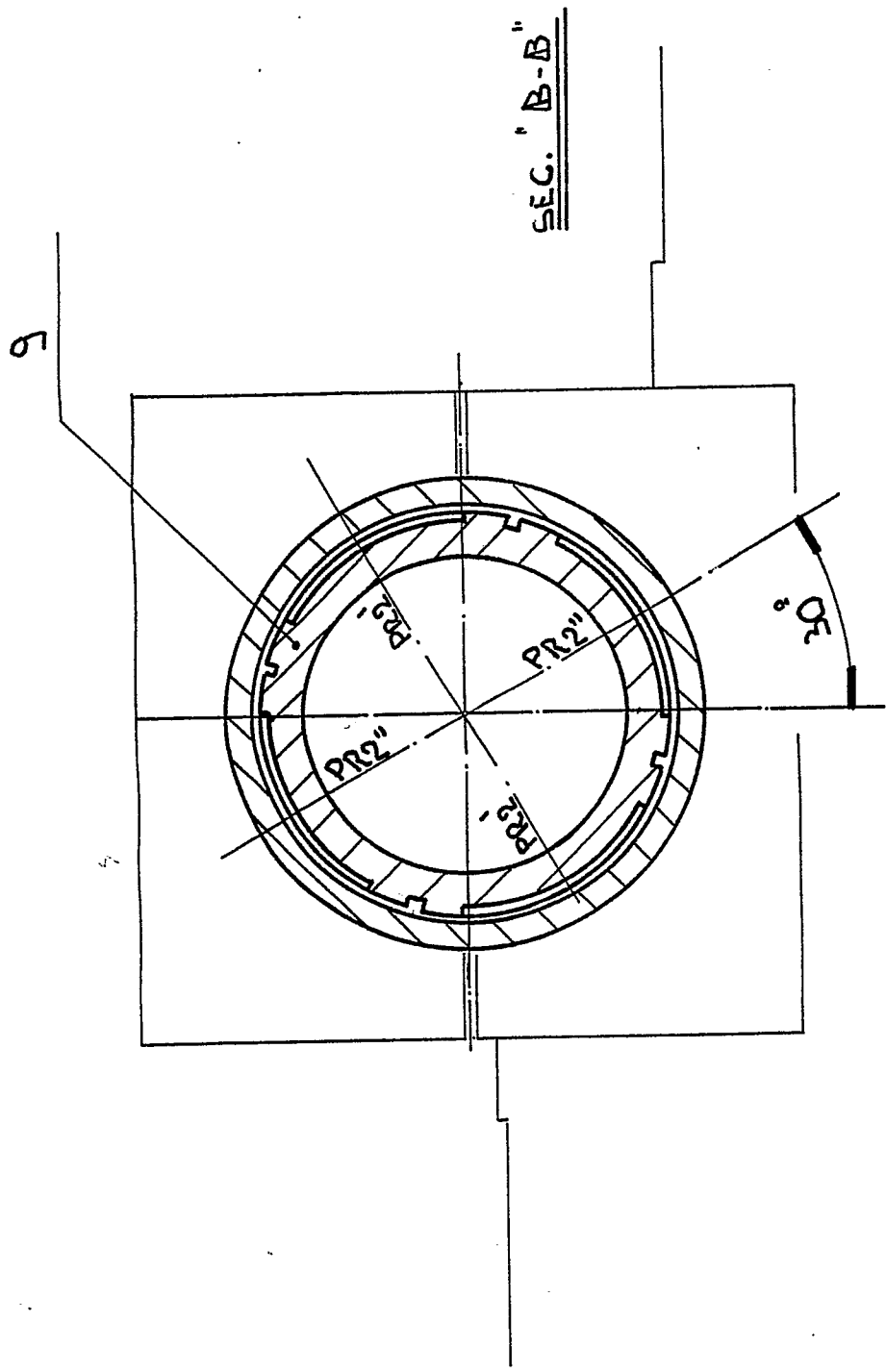
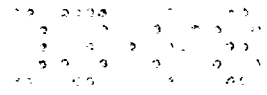

FIG. 5

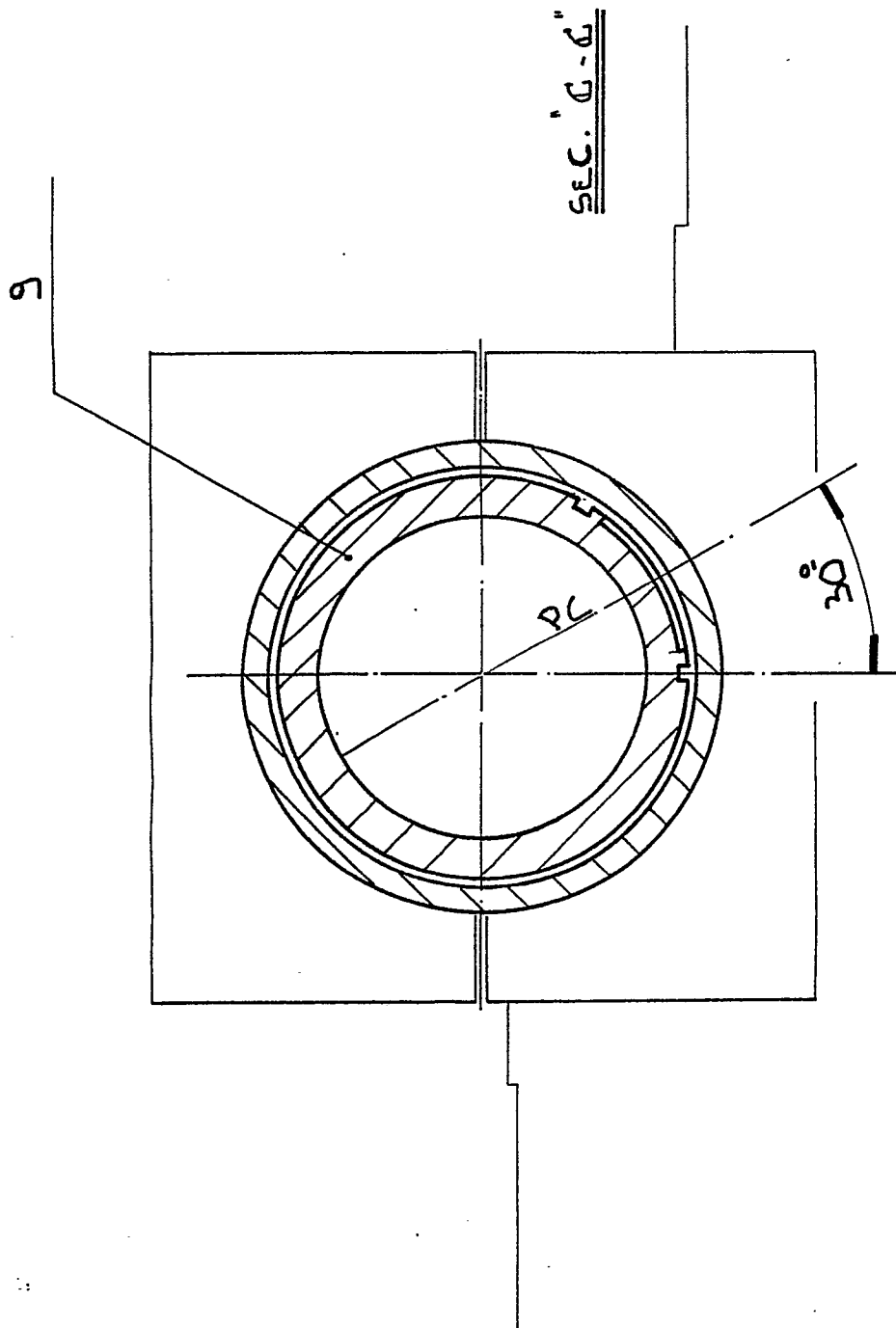
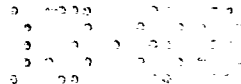

FIG. 6



DOCUMENTS CONSIDERED TO BE RELEVANT			
Category	Citation of document with indication, where appropriate, of relevant passages	Relevant to claim	CLASSIFICATION OF THE APPLICATION (Int. Cl.4)
A	US-A-4 193 644 (MIYASHITA et al.) * Figures 7,8,10; claims 1-3 * ---	1	B 65 C 9/22 B 05 C 11/02
A	FR-A-1 154 188 (BRITISH CELLOPHANE) * Page 5, line 39 - column 2, line 52; figures 3,4 * ---	1	
A	FR-A-2 429 156 (JAGENBERG-WERKE) ---		
A	US-A-3 382 130 (DELLA VITE) ---		
A	RESEARCH DISCLOSURE, section 243, no. 27, 10th July 1984, AN 84-205356 (33), PN, disclosure no. 243027, Derwent Publications, Ltd, London, GB; "Rolling mill roll - consists of roll supported by stationary beam through sequence of hydrostatic pads" -----		
			TECHNICAL FIELDS SEARCHED (Int. Cl.4)
			B 65 C B 05 C
The present search report has been drawn up for all claims			
Place of search THE HAGUE		Date of completion of the search 05-10-1988	Examiner DEUTSCH J. P. M.
CATEGORY OF CITED DOCUMENTS		T : theory or principle underlying the invention E : earlier patent document, but published on, or after the filing date D : document cited in the application L : document cited for other reasons ----- & : member of the same patent family, corresponding document	
X : particularly relevant if taken alone Y : particularly relevant if combined with another document of the same category A : technological background O : non-written disclosure P : intermediate document			