

(19)



Europäisches Patentamt

European Patent Office

Office européen des brevets



(11)

EP 0 330 736 B2

(12)

NEW EUROPEAN PATENT SPECIFICATION

(45) Date of publication and mention
of the opposition decision:

19.01.2000 Bulletin 2000/03

(51) Int. Cl.⁷: **B41F 27/12**

(45) Mention of the grant of the patent:

13.10.1993 Bulletin 1993/41

(21) Application number: **88118939.3**

(22) Date of filing: **14.11.1988**

(54) **Tensionless plate lock-up**

Spannungsloser Plattenverschluss

Dispositif de verrouillage sans tension

(84) Designated Contracting States:

CH DE FR GB LI SE

(30) Priority: **29.02.1988 US 161640**

(43) Date of publication of application:

06.09.1989 Bulletin 1989/36

(73) Proprietor:

**Goss Graphic Systems, Inc.
Westmont, Illinois 60554-5546 (US)**

(72) Inventor:

**Wallschlaeger, Alan Robert Sr.
Elmhurst Illinois 60126 (US)**

(74) Representative:

**Lippich, Wolfgang, Dipl.-Pys., Dr.rer.nat. et al
Patentanwalt Samson & Partner,
Widenmayerstrasse 5
80538 München (DE)**

(56) References cited:

EP-A- 0 039 765

DE-A- 2 220 245

DE-C- 3 116 506

FR-A- 1 352 571

EP 0 330 736 B2

Description

[0001] The present invention relates to offset lithographic presses and more particularly to lock-up mechanisms for holding the thin, flexible litho plates to the surface of the plate roll.

[0002] The art of printing by offset lithography involves the use of thin, flexible plates which are basically planographic, that is without relief, and which are treated so that the surfaces have areas which attract or repel oil and water to create areas of image differentiation. To mount the litho plates on the surface of the press plate rolls, it is essential to insure that the plate conforms closely to the outer surface of the plate roll. Mounting is usually effected by forming a longitudinal slot in the plate roll and inserting therein one of a variety of biasing or clamping devices called lockups. Often the leading edge of the plate is bent back on itself so that the bent portion can fit over the edge formed in the roll by the longitudinal slot and then be held in position by some form of spring or clamp. Alternatively, mechanisms have been provided in which the plate leading edge has been rigidly clamped.

[0003] An example of the type of plate lock-up mechanism in which the leading edge of the plate is clamped can be seen by referring to US-A-4,421,024. In this arrangement, the plate leading end portion E is held between two parts 5 and 6 which are of an approximate trapezoidal shape. The two parts 5 and 6 are urged inwardly to clamp the end of the plate within slot 3 by means of the spring 8. The trailing end of the plate, which is identified by the letter A, is held between the sloped surface of part 6 and the similarly sloped wall 10 of slot 3.

[0004] Another example of a plate lock-up is seen in US-A-3,757,691 where the leading edge of plate 11 is held by one leaf of a spring member 16 while the trailing edge of plate 11 is held by another finger of the spring member 16. An elongated cam 18 is used to change the spring pressure exerted against the plate for purposes of unlocking and locking the plate in and from operating position, respectively.

[0005] A plate lock-up mechanism which is somewhat related to that of US-A-3,757,691 is US-A-3,626,848 where a spring member is used to hold down the leading edge of plate 11 around the undercut side of the slot and cam 40 is used to urge the hook 35 against the trailing end 13. Examples of other plate lock up mechanisms may be found in US-A-3,608,847 and US-A-3,095,811.

[0006] In EP-A-0 039 765 a lock-up mechanism as defined in the preamble of claim 1 is disclosed. With this known lock-up mechanism a clamping body having wedge-like disposed compression surfaces is pressed against two leaf spring arms, each of which is in contact with an undercut locking surface of the printing cylinder for clamping the ends of the flexible printing plate between one of the undercut locking surfaces and the

respective leaf spring arm.

[0007] In FR-A-1 352 571 another lock-up mechanism for holding a flexible printing plate to a printing cylinder is disclosed. With this known lock-up mechanism the ends of the flexible printing plate are introduced into the opening of a clamping bar disposed within the slot of the printing cylinder. The opening of the clamping bar is defined by two surfaces inclined relative to each other. A cylindrical clamping bar is disposed within the opening of the other clamping bar and supported by an elastic finger fixed to the printing cylinder. The outer clamping bar having said opening for said cylindrical inner clamping bar is radially moveable relative to the inner clamping bar. The ends of the printing plate are clamped between the inner cylindrical clamping bar and one of the two inclined surfaces, with this surface contacting the ends of the printing plate being a radially extending surface and the other surface inclined thereto serving as a runway for the cylindrical inner clamping bar.

[0008] It is a principal object of this invention to provide an improved plate lock-up mechanism in which both the leading and trailing edges of the plate are held securely in position during operation.

[0009] An additional object of this invention is to provide a printing plate lock-up mechanism which the plate can be installed on the plate roll and removed therefrom without the necessity of having installation or removal equipment.

[0010] An additional object of this invention is to provide a plate lock-up mechanism in which the width of the plate gap is held to a minimum.

[0011] A further object of this invention is to provide an improved plate lock-up mechanism which can be adapted for use with plate rolls having longitudinal slots that were structured for use with previously existing plate lock-up mechanisms.

[0012] These and additional objects and advantages of the invention as defined in claim 1 will be in part obvious and in part explained by reference to the accompanying specification and drawings, in which:

Fig. 1 is a partial cross-sectional view through an improved plate lock-up mechanism in which the plate lock-up gap is held to a minimum;
Fig. 2 is a partial plan elevation of the lock-up of Fig. 1;
Fig. 3 is a cross-sectional view similar to Fig. 1 showing a modified form of plate lock-up; and
fig. 4 is a cross-sectional view similar to those of Figs. 1 and 3 showing yet another modified plate lock-up.

Description of the Preferred Embodiment

[0013] In order to more clearly understand the present invention, reference is made to the drawings and more particularly to Fig. 1. In this figure, numeral 10 indicates a section through a portion of a plate roll upon which a

plate 11 disposed. The plate roll 10 is formed with longitudinal groove 12 in its outer surface 13, the longitudinal slot extending all the way across the width of the plate roll.

[0014] Longitudinal slot 12 is shown as being undercut to define a pair of opposed surfaces 15 which provide locking surfaces against which both the leading and the trailing ends of plate 11 can be abutted. From the slot inwardly, the substantially flat or planar clamping surfaces 15 terminate in a curved wall, the shape being of no particular significance, since the shape is largely dictated by the machining operation selected for forming the slot.

[0015] In Fig. 1 it can be seen that the leading edge 20 of plate 11 has been folded back at an acute angle to the plate (and to the surface of the roll) so that it fits over the nose portion 21 of the roll 10. The trailing edge 22 is not, unlike the leading edge, bent back on itself but rather extends over the opening of longitudinal slot 12 so that it is in abutment with the innermost surface of leading edge 20.

[0016] The leading and trailing edges 20 and 22 are held against each other and against one of the clamping surfaces 15, by the locking means 25. Each locking means has a curved outer surface 26 for contacting the ends of the flexible plate and clamping them against the locking surface 15. It will be noted that the radius of curvature of each of the locking elements 25 is such that the contact between the curved outer surface with the substantially planar surface 15 is one of basically line contact, so that firm contact is made with the surface of the printing plate. By having line as opposed to areal contact with the plate, insertion and removal of the plate ends from locking engagement are made easier than would otherwise be the case.

[0017] As can be seen by referring to Fig. 2 of the drawings, the locking means 25 are spaced at substantially equal intervals along the length of the longitudinal slot 12 across the width of plate roll 10. It will be appreciated by consideration of Figs. 1 and 2 together that, in the structure shown, each of the locking elements 25 is substantially cylindrical in shape.

[0018] In order to dispose the elements 25 at proper intervals along the length of slot 12 and to urge them outwardly against the clamping surfaces 15, a spacer bar 30 is disposed within the slot. This bar has a plurality of upwardly and outwardly extending mounting posts or spacing studs 31 each of which is surrounded by a compression spring 32. In order that the locking elements 25 be urged outwardly and retained in position, the bottom part of each of the elements 25 contains a cylindrical bore 33 for reception of the upper end of a spring 32. By this combination of stud 31 and opening 33, it is possible for the springs 32 to retain each element 25 in a predetermined or preselected location while urging the locking element 25 curved outer surface toward engagement with a planar surface 15.

[0019] Utilizing the configuration shown in Fig. 1,

where longitudinal slot 12 is formed with two undercut interlocking surfaces 15, it is possible for the plate roll to be utilized for rotation in either a clockwise or a counter-clockwise direction. In either case, the lock-up is performed in the manner shown in Fig. 1, although two ends would be located on the right hand side of locking element 25 in case rotation in the opposite direction were desired. In order to lock up a plate, it is necessary only to depress the locking elements 25 slightly by inserting the leading end 20 into the longitudinal slot. The plate is then wrapped all the way around the roll and the trailing edge inserted into the slot so that it rides down against the inner surface of leading edge 20 to arrive at the assembled and locked position illustrated in the drawings. With this particular configuration, it will be appreciated that upon rotation of the plate roll against the blanket cylinder, there tends to be a flattening and ironing out of the plate so that it is urged tightly against the outer surface 13 of the plate roll. The slight elongation that often occurs in the plate then pushes the end further into the region between locking element 25 and locking surface 15 to hold the plate in tight operating relationship.

[0020] An important feature of the present lock-up is its ability for use in longitudinal slots that have been used in existing plate rolls in the field. Figs. 3 and 4 illustrate the manner in which this can be effected. Referring first to Fig. 3, it will be seen that the slot 35 has been formed with only one undercut surface 36 while the other side wall of the slot is essentially vertical. In this case, there is shown a spacer bar mechanism 38 that is secured into a small secondary recess by means of a bolt 39. The use and positioning of such spacer bars is common in the art and does not form part of this invention. In this configuration, the generally cylindrical locking element 40 corresponds to the locking element 25 of Fig. 1 and it is urged outwardly by means of compression springs 41. In the configuration of Fig. 3, the bottom part of spring 41 is received into an appropriately formed recess 42 in the bottom of slot 33 while the upper end of spring 41 is received into a recess formed in the bottom part of a vertically movable spacer 43. The spacer 43 is formed with a generally arcuately formed receptacle-like surface 44 into which the locking element 40 can be received. It should be pointed out that the spacing element 43 contains an integrally formed wall 45 on each end which acts to define the lateral limits of the arcuate surface 44 and prevent locking element 40 from moving laterally in the general direction of the length of longitudinal slot 33.

[0021] Turning now to the modification shown in Fig. 4 of the drawings, common numbers are used to illustrate the parts that are in common with the locking mechanism defined in Fig. 3 of the drawings. In the case of Fig. 4, it will be obvious that the slot 35 is of a totally different configuration than that of the slots found in Figs. 1 and 3. In this case, the bottom of the slot is provided with cup-shaped inserts 46 which will act to receive the lower

ends of springs 41 in the same manner as do the openings provided in the configuration of Fig. 3. Since slot 35 is larger than that of Fig. 3, filler means 52 is mounted along one side of the slot and held in position by means of threaded elements 53 so that one of the undercut surfaces 15 acts to isolate the locking element 40 from the adjoining undercut surface. By utilizing the spacing element, the operation of the lock-up becomes identical to that of Fig. 3 of the drawings. It should be pointed out that in the cases of the lock-up shown in Figs. 3 and 4, the plate roll 10 can be used in rotation only in one direction since it is not possible to have the leading edge locked on the right half of the device as seen in these Figures.

Claims

1. Lock-up mechanism for holding a flexible printing plate (11) to a printing cylinder (10) having a longitudinal slot (12, 35) formed in its surface (13) to define at least one undercut locking surface (15, 36) against which both ends (20, 22) of said flexible printing plate (11) are clamped, comprising locking means (25, 40) for clamping the ends (20, 22) of said flexible printing plate (11) against said undercut locking surface (15, 36) and spring biasing means (32, 41) disposed in operative compression between said locking means (25, 40) and the bottom of said longitudinal slot (12, 35) to urge said locking means (25, 40) outwardly against said undercut locking surface (15, 36), characterized in that said locking means (25, 40) includes a curved outer surface (26) for directly contacting the ends (20, 22) of said flexible printing plate (11) and clamping them against said undercut locking surface (15, 36) and in that said locking means comprises a plurality of individual locking elements (25, 40) substantially evenly spaced along the length of said longitudinal slot (12, 35).
2. Lock-up mechanism as defined in claim 1 wherein said locking means (25, 40) is substantially cylindrical in shape.
3. Lock-up mechanism as defined in claim 1 wherein said undercut locking surface (15, 36) is substantially planar and the radius of curvature of the outer surface (26) of said locking means (25, 40) is such as to create substantially line contact between said locking means (25, 40) and said locking surface (15, 36).
4. Lock-up mechanism as defined in claim 1 wherein spacing means (30, 38, 43) are disposed within said longitudinal slot (12, 35) to receive said locking elements (25, 40) and said spring biasing means (32, 41) so that said locking elements (25, 40) are

held in predetermined position along the length of said longitudinal slot (12, 35).

5. Lock-up mechanism as defined in claim 1 wherein said spring biasing means (41) are disposed within mounting openings (42) formed along the length of said longitudinal slot (35).
6. Lock-up mechanism as defined in claim 1 wherein said spring biasing means (32) are mounted on spacing studs (31) disposed along the length of said longitudinal slot (12).
7. Lock-up mechanism as defined in claim 1 wherein said longitudinal slot (12) defines two undercut locking surfaces (15) and said locking means (25) has a curved outer surface (26) for contacting both said undercut locking surfaces (15) simultaneously.
8. Lock-up mechanism as defined in claim 2 wherein said locking means (25) are formed with an opening (33) to receive one end of said spring biasing means (32).
9. Lock-up mechanism as defined in claim 1 which includes a printing plate (11) secured to said printing cylinder (10) with the leading and trailing ends (20, 22) in contact with each other and clamped between said undercut locking surface (15, 36) of said locking means (25, 40).
10. Lock-up mechanism as defined in claim 1 wherein said longitudinal slot (35) defines two undercut surfaces (15) and filler means (52) is mounted within said slot (35) adjacent one of said undercut surfaces (15) to contact said locking means (40) and isolate it from said one undercut surface (15).

Patentansprüche

1. Festspannmechanismus zum Halten einer flexiblen Druckplatte (11) an einem Druckzylinder (10), der einen in seiner Oberfläche (13) gebildeten Längsschlitz (12, 35) aufweist, um wenigstens eine hinterschnittene Sperrfläche (15, 36) zu bilden, gegen die beiden Enden (20, 22) der flexiblen Druckplatte (11) festgespannt sind, enthaltend: Sperrmittel (25, 40) zum Festspannen der Enden (20, 22) der flexiblen Druckplatte (11) gegen die hinterschnittene Sperrfläche (15, 36) und Federvorspannmittel (32, 41), die in einem komprimierten Wirkzustand zwischen den Sperrmitteln (25, 40) und dem Boden des Längsschlitzes (12, 35) angeordnet sind, um die Sperrmittel (25, 40) auswärts gegen die hinterschnittene Sperrfläche (15, 36) zu beaufschlagen, dadurch gekennzeichnet, daß die Sperrmittel (25, 40) eine gekrümmte Außenfläche (26) aufweisen, um direkt mit den Enden (20,

- 22) der flexiblen Druckplatte (11) in Kontakt zu treten und sie gegen die hinterschnittene Sperrfläche (15, 36) festzuspannen, und daß die Sperrmittel mehrere einzelne Sperrelemente (25, 40) umfassen, die im wesentlichen gleichmäßig entlang der Längsausdehnung des Längsschlitzes (12, 35) beabstandet sind.
2. Festspannmechanismus nach Anspruch 1, bei welchem die Sperrmittel (25, 40) von im wesentlichen zylindrischer Form sind.
3. Festspannmechanismus nach Anspruch 1, bei dem die hinterschnittene Sperrfläche (15, 36) im wesentlichen eben ist und der Krümmungsradius der Außenfläche (26) der Sperrmittel (25, 40) von solcher Art ist, daß im wesentlichen eine Linienberührung zwischen den Sperrmitteln (25, 40) und der Sperrfläche (15, 36) eintritt.
4. Festspannmechanismus nach Anspruch 1, bei dem Abstandshaltermittel (30, 38, 43) innerhalb des Längsschlitzes (12, 35) angeordnet sind, um die Sperrelemente (25, 40) und die Federvorspannmittel (32, 41) aufzunehmen, so daß die Sperrelemente (25, 40) in einer vorbestimmten Stellung über die Längsausdehnung des Längsschlitzes (12, 35) gehalten werden.
5. Festspannmechanismus nach Anspruch 1, bei dem die Federvorspannmittel (41) innerhalb von Montageöffnungen (42) angeordnet sind, die über die Länge des Längsschlitzes (35) angebracht sind.
6. Festspannmechanismus nach Anspruch 1, bei dem die Federvorspannmittel (32) auf Abstandshalterstützen (31) angebracht sind, die über die Länge des Längsschlitzes (12) angeordnet sind.
7. Festspannmechanismus nach Anspruch 1, bei dem der Längsschlitz (12) zwei hinterschnittene Sperrflächen (15) bildet und die Sperrmittel (25) eine gekrümmte Außenfläche (26) aufweisen, um mit beiden hinterschnittenen Sperrflächen (15) gleichzeitig in Kontakt zu treten.
8. Festspannmechanismus nach Anspruch 2, bei dem die Sperrmittel (25) mit einer Öffnung (33) ausgebildet sind, um ein Ende der Federvorspannmittel (32) aufzunehmen.
9. Festspannmechanismus nach Anspruch 1, der eine Druckplatte (11) umfaßt, welche an dem Druckzylinder (10) befestigt ist, wobei ihr vorderes und ihr hinteres Ende (20, 22) in Berührung miteinander sind und zwischen der hinterschnittenen Sperrfläche (15, 36) der Sperrmittel (25, 40) festgespannt sind.

10. Festspannmechanismus nach Anspruch 1, bei dem der Längsschlitz (35) zwei hinterschnittene Oberflächen (15) bildet und ein Füllmittel (52) innerhalb des Schlitzes (35) angrenzend an eine der hinterschnittenen Flächen (15) angebracht ist, um mit den Sperrmitteln (40) in Berührung zu treten und sie von der einen hinterschnittenen Fläche (15) getrennt zu halten.

10 Revendications

1. Mécanisme de blocage pour fixer une plaque d'impression flexible (11) à un cylindre d'impression (10) présentant une fente longitudinale (12, 35) formée dans sa surface (13) pour définir au moins une surface de blocage à dégagement (15, 36) contre laquelle les deux parties extrêmes (20, 22) de ladite plaque d'impression (11) sont serrées, comprenant un moyen de blocage (25, 40) pour le serrage des parties extrêmes (20, 22) dudit cliché en caoutchouc (11) contre ladite surface de blocage à dégagement (15, 36) et un moyen de décentrage à ressort (32, 41) disposé en compression active entre ledit moyen de blocage (25, 40) et le bas de ladite fente longitudinale (12, 35) pour forcer ledit moyen de blocage (25, 40) vers l'extérieur contre ladite surface de blocage à dégagement (15, 36), caractérisé en ce que ledit moyen de blocage (25, 40) comporte une surface extérieure courbe (26) pour mettre en contact direct les parties extrêmes (20, 22) de ladite plaque d'impression (11) et les serrer contre ladite surface de blocage à dégagement (15, 36), et en ce que ledit moyen de blocage comprend une pluralité d'éléments de blocage individuels (25, 40) espacés de façon sensiblement régulière sur la longueur de ladite fente longitudinale (12, 25).
2. Mécanisme de blocage selon la revendication 1, sur lequel ledit moyen de blocage (25, 40) est sensiblement de forme cylindrique.
3. Mécanisme de blocage selon la revendication 1, sur lequel ladite surface de blocage à dégagement (15, 36) est sensiblement plane, et dans lequel le rayon de courbure de la surface extérieure (26) dudit moyen de blocage (25, 40) est tel qu'il crée sensiblement un contact de ligne entre ledit moyen de blocage (25, 40) et ladite surface de blocage (15, 36).
4. Mécanisme de blocage selon la revendication 1, dans lequel des moyens d'écartement (30, 38, 43) sont disposés à l'intérieur de ladite fente longitudinale (12, 35) pour recevoir lesdits éléments de blocage (25, 40) et lesdits moyens de décentrage à ressort (32, 41), de sorte que lesdits éléments de blocage (25, 40) sont maintenus dans une position

prédéterminée sur la longueur de ladite fente longitudinale (12, 35).

5. Mécanisme de blocage selon la revendication 1, dans lequel lesdits moyens de décentrage à ressort (41) sont disposés à l'intérieur d'ouvertures de montage (42) formées sur la longueur de ladite fente longitudinale (35). 5

6. Mécanisme de blocage selon la revendication 1, dans lequel lesdits moyens de décentrage à ressort (32) sont montés sur des goujons (31) disposés sur la longueur de ladite fente longitudinale(12). 10

7. Mécanisme de blocage selon la revendication 1, dans lequel ladite fente longitudinale (12) définit deux surfaces de blocage à dégagement (15) et dans lequel ledit moyen de blocage (25) présente une surface extérieure courbe (26) pour faire entrer simultanément en contact les deux dites surfaces de blocage à dégagement (15). 15
20

8. Mécanisme de blocage selon la revendication 2, dans lequel lesdits moyens de blocage (25) sont formés avec une ouverture (33) pour recevoir une extrémité dudit moyen de décentrage à ressort (32). 25

9. Mécanisme de blocage selon la revendication 1, qui comporte une plaque d'impression (11) fixée audit cylindre d'impression (10), les parties extrêmes avant et arrière (20, 22) étant en contact l'une avec l'autre et serrées entre ladite surface de blocage à dégagement (15, 36) dudit moyen de blocage (25, 40). 30
35

10. Mécanisme de blocage selon la revendication 1, dans lequel ladite fente longitudinale (35) définit deux surfaces à dégagement (15) et dans lequel un moyen de remplissage (52) est monté à l'intérieur de ladite fente longitudinale (35) de façon adjacente à l'une desdites surfaces à dégagement (15) pour entrer en contact avec ledit moyen de blocage (40) et l'isoler de ladite surface à dégagement (15). 40
45

50

55

Fig. 1.

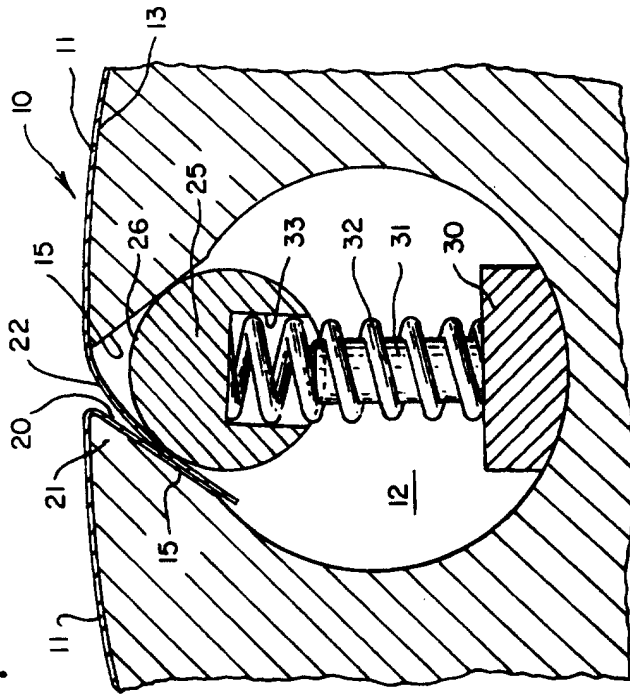

Fig. 2.

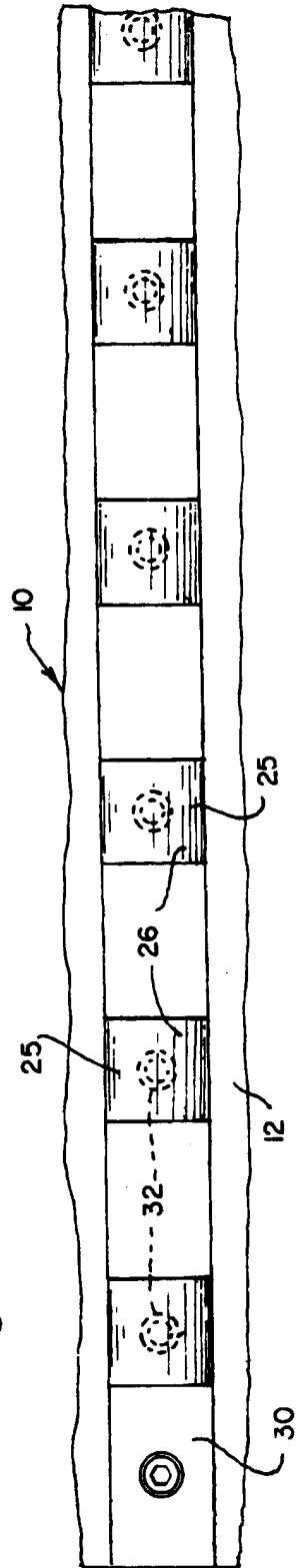

Fig. 3.

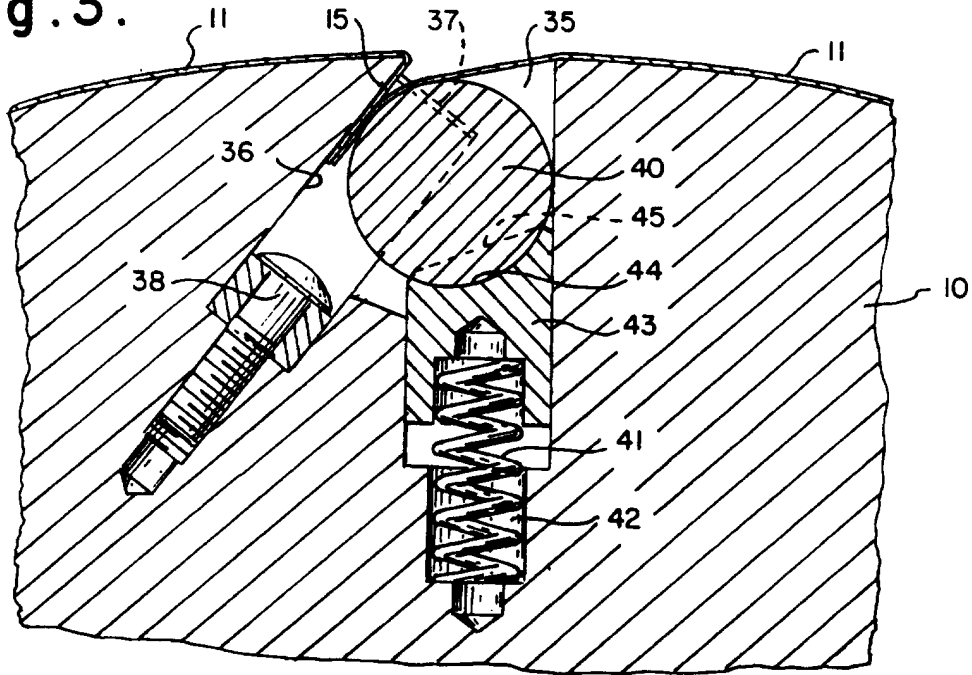

Fig. 4.

