



EUROPEAN PATENT SPECIFICATION

Date of publication of patent specification :
02.12.92 Bulletin 92/49

Int. Cl.⁵ : **B42C 7/00**

Application number : **89200916.8**

Date of filing : **12.04.89**

Device for assembling (disassembling) a packing unit consisting of four file mechanisms.

Priority : **14.04.88 NL 8800967**

Proprietor : **EGIDIUS JANSSEN N.V.**
Witveldweg 14 P.O.B. 4007
NL-5950 AA Belfeld (NL)

Date of publication of application :
18.10.89 Bulletin 89/42

Inventor : **Stoffels, Cornelis Wilhelmus**
Antonius
Paul Guillaumestraat 6
NL-5931 CK Tegelen (NL)

Publication of the grant of the patent :
02.12.92 Bulletin 92/49

Designated Contracting States :
AT BE CH DE ES FR GB GR IT LI LU NL SE

Representative : **Vollebregt, Cornelis Jacobus**
et al
Algemeen Octrooibureau P.O. Box 645
NL-5600 AP Eindhoven (NL)

References cited :
DE-B- 1 301 012

EP 0 337 574 B1

Note : Within nine months from the publication of the mention of the grant of the European patent, any person may give notice to the European Patent Office of opposition to the European patent granted. Notice of opposition shall be filed in a written reasoned statement. It shall not be deemed to have been filed until the opposition fee has been paid (Art. 99(1) European patent convention).

Description

The invention relates to a device for assembling (disassembling) a packing unit consisting of four file mechanisms.

Usual file mechanisms, provided in document files for filing away paper and the like, provided with a base plate and a pair of bows and an operating lever for opening and closing the bows have been known for many decades. Such file mechanisms are produced in large numbers on machines made for that purpose and they must be transported from this machine to machines which provide the mechanisms in the files. Providing the mechanisms in the files may thereby take place in the same factory where the mechanisms are produced or in a factory at another location. For transport and storage such file mechanisms are assembled into so-called packing units, each consisting of four file mechanisms. In such a packing unit the file mechanisms are arranged in pairs, being in line, with the ends of the operating levers projecting from the base plates directed towards each other, whilst a pair of such aligned mechanisms are moved with their bows between the bows of a further pair of aligned file mechanisms, so that the bows of the four file mechanisms assembled into a packing unit are enclosed, as it were, between the base plates of the file mechanisms.

Thus forming file mechanisms into a packing unit has always been done by hand so far. This is a time-consuming and tiring activity, however, in view of the fact that the wrist joints of the persons assembling such packing units are subjected to heavy stresses.

Furthermore it is necessary to disassemble the packing units again at the location where the file mechanisms are to be provided in the files and to put the mechanisms in their correct position for being supplied to the machine providing the mechanisms in the files. Also this is still being done by hand, but also here difficulties have arisen, particularly in view of the fact that the number of mechanisms which is mounted in files per time unit by means of such machines is growing larger and larger, and the disassembly of the packing unit is putting a limit to the rate of speed at which the machine can operate.

For a long time there has been a demand for a device for assembling packing units as well as for a device for disassembling packing units, therefore.

According to the invention the assembly or disassembly of a packing unit can be effected by means of a device which is provided with a pair of receiving parts, on each of which a pair of file mechanisms, being in line, can be placed with their base plates, whilst means have been provided for pivoting the two receiving parts relative to each other between a first position for placing (removing) the file mechanisms on (from) the receiving parts and a second position, in which the file mechanisms are enclosed between the receiving

parts with their bows moved between each other.

When using the device according to the invention the assembly and disassembly of the packing unit can be done quickly and efficiently by mechanic means.

The invention will be further explained herein-after with reference to embodiments of the device according to the invention diagrammatically illustrated in the accompanying figures.

Fig 1 is a top view of a pair of file mechanisms, which are arranged in line in a position suitable for being taken up in a packing unit.

Fig 2 is a top view of a packing unit consisting of four file mechanisms.

Fig 3 is a top view of a part of an embodiment of a device according to the invention.

Fig 4 is a top view of a part of the device according to the invention, which part joins the part illustrated in fig 3.

Fig 5 is a view, partly in section and partly in elevation, of fig 4, seen according to the arrow V in fig 4.

Fig 6 is a top view of a part of the device according to the invention, which part joins up with the part of device illustrated in fig 4.

Fig 7 is a view of a part of fig 6, seen in the direction of arrow VII.

Fig 8 is a diagrammatic top view of a device according to the invention, when used for disassembling packing units.

Fig 9 is a diagrammatic illustration of a variant of a part of the device illustrated in fig 8.

Fig 1 illustrates a pair of file mechanisms 1 which are provided, in the usual and known manner, with a base plate 2 and a pair of bows 3 provided on said base plate 2, which bows can be opened and closed by means of an operating lever 4. For forming a packing unit a pair of these file mechanisms are placed in line, as illustrated in plan view in fig 1, whereby the bows of the two file mechanisms are located side by side, therefore, and the free end of an operating lever has been put through a neighbouring bow of an adjacent file mechanism and is located above the base plate 2 of said adjacent file mechanism.

As is furthermore illustrated in fig 2 such a group of two aligned file mechanisms for forming a packing unit consisting of four file mechanisms is put together with a corresponding pair of file mechanisms, such that the bows of said four file mechanisms are enclosed, lying side by side, between the four base plates, as can be seen clearly in fig 2.

For assembling and disassembling the packing units by mechanic means use may be made of the device illustrated in figs 3 - 7.

The part of the device which is diagrammatically illustrated in plan view in Fig. 3 joins up with a device for producing the file mechanisms. The file mechanisms always leave the machine in question in the same position and from this machine they are sup-

plied to the device according to the invention via a downwardly sloping chute 5. The file mechanisms thereby move along the chute with their longitudinal axes parallel to the longitudinal direction of the chute and all with their operating levers extending in the same direction.

The lower end of the chute runs into one end of a conveyor belt 6 which is supported by the frame of the device and which can be driven by means of driving means (not shown), and whose upper part will move in the direction according to arrow A during operation in order to move the file mechanisms 1 in the direction according to arrow A.

Near the end of the conveyor belt 6 joining up with the chute 5 there is arranged a change-over formed by a pair of plates 7 and 8 arranged in the shape of a V, said change-over being pivotable relative to the frame about a vertical axis 9 by means of a setting cylinder 10. When there are malfunctions the change-over 7, 8 can be pivoted clockwise, seen in fig 3, by means of the setting cylinder 10, so that the end of the change-over 7, 8 directed towards the chute 5 will come to lie near the lower end of the chute, seen in fig 3, as a result of which the file mechanisms coming from the chute can be discharged sideways, i.e. upwards seen in fig 3.

As is furthermore illustrated in fig 3 a pair of horizontal pins 11 and 12 are provided near the side of the conveyor belt, said pins being supported in their longitudinal direction and transversely to the longitudinal direction of the conveyor belt 6 by bushes 13 fixed in the frame. At their ends remote from the belt 6 the pins 11 and 12 are provided with forked heads 14 which are coupled, by means of pivot pins 15, to the ends of a lever 16 which is pivotable relative to the frame about a pin 17 extending parallel to the pins 15. The lever 16 in its turn is coupled to the piston rod 18 of a setting cylinder 19 which is fixed to the frame, so that the lever 16 can be pivoted to and fro by means of the setting cylinder 19. It will be apparent that when the one pin, e.g. the pin 11 as illustrated in fig 3, is retracted from its position above the belt 6 the other pin 12 will be located with its end above the belt.

Thus the pins can alternately be put in the path of movement of the file mechanisms supplied by means of the conveyor belt 6 in order to space the file mechanisms supplied in a continuous row from one another and place them one by one opposite a stamp 20 arranged near the end of the conveyor belt 6, which stamp is movable to and fro across the conveyor belt, transversely to the longitudinal direction of the conveyor belt 6, by means of a setting cylinder 21 fixed to the frame.

At the side of the conveyor belt 6 remote from the stamp 20 there is arranged a guideway 22, which extends between the side of the conveyor belt 6 and a rotary table 23 which is pivotable about a vertical axis.

The rotary table can be pivoted through 180°

about its vertical axis of rotation by means of an adjusting means 24. Furthermore a longitudinal groove 25 is provided in the upper surface of the rotary table, said groove having such dimensions that the base plate 2 of a file mechanism fits therein.

During operation the file mechanisms will be supplied, one by one, to the rotary table 23, such that they will come to lie with their base plate in the groove 25.

A file mechanism present in the groove can be pushed from the rotary table 23, in the direction according to arrow B, by means of a pushing means 26 which is fixed to the end of a piston rod 27 of a setting cylinder 28 fixed to the frame. As is furthermore illustrated in fig 3 a feeler 28' is fixed to the end of the piston rod 27 projecting from the setting cylinder 28 at the side remote from the pushing plate 26, said feeler being movable to and fro between a pair of adjustable stops 29 and 30 in order to determine the length of the stroke of the pushing means.

When during operation a file mechanism has been pushed from the rotary table by means of the pushing means 26, in the direction according to arrow B, and a next file mechanism has been placed on the rotary table said rotary table will first be pivoted through 180° prior to pushing said next file mechanism from the rotary table, so that the file mechanisms discharged from the rotary table will be in positions alternately pivoted through 180° relative to each other (position according to fig 1).

As is illustrated in more detail in fig 4 the file mechanisms coming from the rotary table are moved in their longitudinal direction along a gravity conveyor 31 in the direction of a pair of chain conveyors 32 and 33 arranged side by side and parallel to each other.

As is further illustrated in fig 5 each chain conveyor comprises a pair of endless chains 35 guided around sprocket wheels 34, fingers 36 being fixed, regularly spaced from one another, to the links of said chain.

At one end the various chains of the chain conveyor are guided about sprocket wheels 38 fixed to a common shaft 37. To this shaft there is coupled a ratchet and ratchet wheel mechanism 39 provided with a lever 40, which can be pivoted to and fro by means of a setting cylinder 41 for rotating the shaft 37 in steps. It will be apparent that said stepwise rotation of the shaft 37 will also result in a stepwise movement of the chains 35 of the chain conveyors 32 and 33.

The distance between the successive fingers 36 of the chain conveyors approximately corresponds with the width of a base plate 2 of a file mechanism.

Two file mechanisms supplied in succession will therefore be placed in line on the conveyors 32 and 33, whereby care is taken when the machine is adjusted that the two co-axial file mechanisms in question take the position illustrated in fig 1 relative to each other.

Pairs of file mechanisms thus put together by

means of the conveyors 32 and 33 are now moved in the direction according to arrow C.

To the right of the conveyors 32 and 33, seen in fig 4, there are arranged a pair of pushing means 42, which are fixed to the ends of piston rods 43, which form part of setting cylinders 44. Also here the ends of the piston rods 43 projecting from the setting cylinders 44 are provided with feelers 45, which are movable between adjustable stops 46 by means of which the stroke of the pushing means 42 can be adjusted.

When the conveyors 32 and 33 take up a position in which a group of two file mechanisms is located opposite each pushing means the pushing means 42 will be set in action in order to push the file mechanisms in question from the conveyors 32 and 33 in the direction according to arrow D.

From fig 4 it will be apparent that when thus two groups of two file mechanisms are pushed from the conveyors 32 and 33 in the direction according to arrow D one group between said pushed-off mechanisms will remain behind on the conveyors. When the conveyors 32 and 33 make their next stepwise movement said pair of mechanisms will come to lie opposite the lower pushing means 42, seen in fig 4, whilst there will also come to lie a pair of mechanisms opposite the upper pushing means, seen in fig 4. After these mechanisms have also been pushed from the conveyors in the manner described above the conveyors must be moved over a greater distance than with their previous movement in order to place pairs of file mechanisms opposite the two pushing means 42 again. It will be apparent that by a suitable construction of the driving mechanism this can automatically take place in the correct sequence.

The pairs of file mechanisms moved in the direction according to arrow D, which are arranged relative to each other as illustrated in fig 1, are moved over a slide plate 47 towards the part of the device according to the invention illustrated in figs 6 and 7. This part comprises a pair of receiving parts 48 and 49, provided with plate-shaped parts 50, horizontally arranged in the illustrated position, to whose longitudinal edges there are fixed strips 51 having projecting noses for forming rebates 52.

The pairs of file mechanisms supplied in the direction according to arrow D will be moved over the bottom surfaces of the plates 50, whereby the longitudinal side edges of the base plates will be accommodated in the rebates 52. The length of each plate 50 is large enough for receiving a group of two file mechanisms, arranged as illustrated in fig 1, on each of the receiving parts.

As furthermore appears from fig 7 ears 53 are fixed to the sides of the receiving parts directed towards each other. The receiving parts are pivotally coupled to the frame, near their side edges directed towards each other, by means of said ears 53 and horizontal pins 54 extending in the longitudinal direction

of the receiving parts.

To the bottom sides of the receiving means there are fixed supports 55 to which there are coupled, by means of pins 56 extending parallel to the pins 54, the ends of piston rods 57 which form part of setting cylinders 58.

To each piston rod 57 there is fixed a rod 60 projecting from the cylinder and extending parallel to the piston rod, a feeler 61 being fixed to one end of said rod 60. The feeler 61 is movable between adjustable stops 62, by means of which the stroke of the relevant setting cylinder 58 is adjustable.

The construction has been made such that the two receiving parts are pivotable through 90° about the axes 54 by means of the setting cylinders 58, in the direction according to arrow E and F respectively. On pivoting towards each other the bows of the file mechanisms supported by the receiving parts will automatically be moved between one another, so that then the file mechanisms supported in pairs by the receiving parts 48 and 49 will have been put in the position illustrated in fig 2 relative to each other.

Because the edges of the base plates are located within the rebates 52 no undesired movements of the file mechanisms will occur when the receiving parts swing upwards from their horizontal position illustrated in fig 7.

A pushing means 63, which is fixed to the end of a piston rod 65 forming part of a setting cylinder 64, is arranged near the receiving means 48 and 49 for pushing the packing unit which has been formed away from its position between said receiving parts 48 and 49 which are pivoted towards each other. It will be apparent that by moving the pushing means from its position illustrated in fig 6 to the left the unit which has been formed and which is present between the receiving parts can be pushed out in order to be delivered to a table 65, which is arranged at the side of the receiving means remote from the setting cylinder 64. The packing units consisting of four file mechanisms thus supplied to the table can be moved in the direction according to arrow G by means of a pusher stamp 67 which is movable to and fro across the table 65 by means of a setting cylinder 66. The packing units gradually move toward the end of the table thereby. When a desired number of packing units, e.g. four or five, are located opposite a further pusher stamp 68, which is movable to and fro by means of a setting cylinder 69, such an assembly of a desired number of packing units can be moved in the direction according to arrow H toward a take off table 70. From this take off table the packing units may then be transferred to e.g. a box or a container for transport. Said transfer of the packing units may be done by hand or automatically, e.g. by means of magnetizable pick up plates or the like. Several layers, each consisting of a desired number of packing units, may be stacked in the box or the container thereby.

For providing the mechanisms in files they must be supplied to the machine providing the mechanisms in the files in regular succession and all in the same position. A machine having the construction described above is also particularly suitable for disassembling the packing units. This will be explained hereinafter with reference to fig 8.

As is diagrammatically illustrated in fig 8 the packing units may be lifted from a container and be deposited on a table 71, e.g. in layers, by means of an electromagnetic pick up plate or the like. The packing units can then be moved in the direction according to arrow K by means of a pushing means (not shown), so that always one row or packing units lying side by side will come to lie on the upper part of a conveyor belt 72 moving in the direction according to arrow L. This conveyor belt places the packing unit in front of a pushing means 73, which pushes always one packing unit between a pair of receiving parts 74 and 75 corresponding with the receiving parts 48 and 49, which receiving parts 74 and 75 take up the position pivoted towards each other when a packing unit is being pushed between the receiving parts. After a packing unit has thus been moved between the receiving means said receiving means are pivoted apart, so that then each receiving part again supports one pair of file mechanisms which take up a position relative to each other as illustrated in fig 1. Subsequently said file mechanisms are moved on the upper part of a conveyor belt 77 by means of further pushing means 76, said upper part moving in the direction according to arrow M. By means of the conveyor belt 77 the mechanisms are placed opposite the pushing means 78 in the manner illustrated in fig 8, by means of which pushing means 78 the file mechanisms are moved on the rotary tables 79 corresponding with the rotary tables 23, and are moved from said rotary tables on the upper part of a conveyor belt 80 moving in the direction according to arrow N. The file mechanisms will alternately be pivoted through 180° by means of the rotary tables 79 thereby, so that all mechanisms present on the conveyor belt 80 take the same position. By means of the conveyor belt 80 the mechanisms are supplied to a device (not shown), by means of which the mechanisms will be mounted in the files and be fixed therein.

Fig 9 illustrates a variant to the construction according to fig 8. As will be apparent from this figure the left-hand row, seen in this figure, of the mechanisms supplied on the conveyor belt 77 is carried further than the right-hand row. The mechanisms of the right-hand row are thereby moved directly onto the conveyor belt 80, whilst the mechanisms of the left-hand row are supplied to rotary tables 79 in order to be pivoted through 180° prior to being supplied to the conveyor belt 80. When such a construction is used the mechanisms can be handled at a greater speed than with the embodiment according to fig 8.

With the embodiment according to fig 10 the file mechanisms are supplied to rotary tables 81 from the receiving parts 74 and 75. Alternately the file mechanisms supplied to the rotary tables are pivoted through 180° or supplied directly to a conveyor belt 82 moving to and fro, in order to be moved on the conveyor belt 80 from there.

From the above it will be apparent that by means of a machine which has in principle the same construction the assembly of packing units containing four file mechanisms as well as the disassembly of such packing units can be done entirely mechanically.

Claims

1. Device for assembling (disassembling) a packing unit consisting of four file mechanisms provided with a base plate and a pair of bows and an operating lever for opening and closing the bows, the device being provided with a pair of receiving parts, on each of which a pair of file mechanisms, being in line, can be placed with their base plates, whilst means have been provided for pivoting the two receiving parts relative to each other between a first position for placing (removing) the file mechanisms on (from) the receiving parts and a second position, in which the file mechanisms are enclosed between the receiving parts with their bows moved between each other.
2. Device according to claim 1, characterized in that the receiving parts are provided with rebates for accommodating the longitudinal edges of base plates of the file mechanisms.
3. Device according to claims 1 or 2, characterized in that adjusting means are provided by means of which the file mechanisms are movable relative to the receiving parts, both in the first position and in the second position of the receiving parts.
4. Device for assembling packing units according to any one of the preceding claims, characterized in that the device is provided with at least one conveyor by means of which file mechanisms arranged in pairs are supplied to the receiving means, whereby pushing means are arranged near the receiving parts, at the side of the conveyor remote from the receiving means, by means of which pushing means file mechanisms can be moved on the receiving parts.
5. Device according to claim 4, characterized in that the conveyor is provided with stopping means projecting above the plane of the conveyor, between which there fit the base plates of the file mechanisms.

6. Device according to claims 4 or 5, characterized in that upstream of the conveyor, seen in the direction of movement of the conveyor, there is arranged a rotary table to which the file mechanisms are supplied one by one and by means of which the file mechanisms can alternately be pivoted through 180°.
7. Device according to any one of the claims 4 - 6, characterized in that the conveyor is movable in steps.
8. Device according to claims 6 or 7, characterized in that at its upper side the rotary table is provided with a recess in which there fits a base plate of a file mechanism.
9. Device according to any one of the claims 6 - 8, characterized in that for supplying the file mechanisms to the rotary table there is provided a conveyor belt and there is arranged a pushing means near the end of the conveyor belt, by means of which pushing means the mechanisms can be moved from the belt and in the direction of the rotary table.
10. Device according to claim 9, characterized in that stops are provided above the conveyor belt, which stops can be moved to and fro between a first position, in which the stops lie in the path of movement of the file mechanisms, and a second position, in which the stops lie outside the path of movement of the file mechanisms.
11. Device according to claim 10, characterized in that the two stops are coupled to the ends of a lever which is pivotably supported between its ends by the frame and which is pivotable to and fro by means of an adjusting means.
12. Device according to any one of the claims 9 - 11, characterized in that near the upstream end of the conveyor belt there is provided a change-over means which is adjustable between a first position, in which the file mechanisms supplied to the conveyor belt can be moved in the direction of the rotary table by means of the conveyor belt, and a second position, in which the file mechanisms supplied are discharged sideways from the belt by means of the change-over means.
13. Device according to any one of the claims 1 - 3, for disassembling the packing units, characterized in that the device is provided with a supply belt for supplying packing units to the receiving means, whereby a pushing means is provided, at the side of the supply belt remote from the receiving means, for moving the packing units into the

receiving means pivoted towards each other.

14. Device according to claim 13, characterized in that at the discharge side of the receiving means there is provided a further conveyor belt, by means of which file mechanisms arranged in pairs can be supplied in the direction of rotary tables which are arranged at one side of the conveyor belt, whilst at the other side of the conveyor belt there are arranged pushing means, by means of which the file mechanisms arranged in pairs can be moved onto the rotary tables.
15. Device according to claim 14, characterized in that upstreams of the pushing means co-operating with the rotary table, seen in the direction of movement of the conveyor belt moving the mechanisms, there are arranged further pushing means, by means of which file mechanisms can be pushed from the conveyor belt, too.
16. Device according to claim 13, characterized in that rotary tables are provided at the discharge side of the receiving means, which rotary tables are arranged between the receiving means and a conveying means, movable to and fro, from where the file mechanisms can be supplied to a discharge means.

Patentansprüche

1. Vorrichtung zum Zusammenstellen (Auseinandersortieren) einer Verpackungseinheit, die aus vier Ablagemechanismen besteht, die mit einer Grundplatte und einem Paar Bügel und einem Bedienungshebel zum Öffnen und Schließen der Bügel versehen sind, wobei diese Vorrichtung mit einem Paar Aufnahmeteilen versehen ist, wobei auf jedem dieser Aufnahmeteile ein Paar Ablagemechanismen, die ausgerichtet sind, mit ihren Grundplatten angeordnet werden kann, wobei Einrichtungen zum Schwenken der beiden Aufnahmeteile im Verhältnis zueinander zwischen einer ersten Position zum Anordnen (Entfernen) der Ablagemechanismen auf (von) den Aufnahmeteilen und einer zweiten Position, in der die Ablagemechanismen zwischen den Aufnahmeteilen eingeschlossen sind, wobei ihre Bügel zwischeneinander bewegbar vorgesehen sind.
2. Vorrichtung nach Anspruch 1, dadurch gekennzeichnet, daß die Aufnahmeteile mit Falzen zur Aufnahme der Längskanten der Grundplatten der Ablagemechanismen versehen sind.
3. Vorrichtung nach Anspruch 1 oder 2, dadurch gekennzeichnet, daß Stalleinrichtungen vorgesehen

- hen sind, durch die die Ablagemechanismen sowohl in der ersten Position als auch in der zweiten Position der Aufnahmeteile im Verhältnis zu diesen Aufnahmeteilen beweglich sind.
4. Vorrichtung zum Zusammenstellen von Verpackungseinheiten nach einem der vorstehenden Ansprüche, dadurch **gekennzeichnet**, daß diese Vorrichtung mit zumindest einer Beförderungseinrichtung versehen ist, durch die die Ablagemechanismen, die paarweise angeordnet sind, den Aufnahmeeinrichtungen zugeführt werden, wobei Schubeinrichtungen in der Nähe der Aufnahmeteile an der Seite der Beförderungseinrichtung angeordnet sind, die von den Aufnahmeeinrichtungen entfernt ist, wobei die Ablagemechanismen durch diese Schubeinrichtungen auf den Aufnahmeteilen bewegt werden können.
5. Vorrichtung nach Anspruch 4, dadurch **gekennzeichnet**, daß die Beförderungseinrichtung mit Stoppeinrichtungen versehen ist, die sich über die Ebene der Beförderungseinrichtung erstrecken, zwischen denen die Grundplatten der Ablagemechanismen eingefügt sind.
6. Vorrichtung nach Anspruch 4 oder 5, dadurch **gekennzeichnet**, daß stromaufwärts der Beförderungseinrichtung, in der Bewegungsrichtung der Beförderungseinrichtung gesehen, ein Drehteller angeordnet ist, dem die Ablagemechanismen einzeln zugeführt werden und durch den die Ablagemechanismen im Wechsel um 180° gedreht werden können.
7. Vorrichtung nach einem der Ansprüche 4 bis 6, dadurch **gekennzeichnet**, daß die Beförderungseinrichtung schrittweise bewegt werden kann.
8. Vorrichtung nach Anspruch 6 oder 7, dadurch **gekennzeichnet**, daß der Drehteller an seiner Oberseite mit einer Vertiefung versehen ist, in die die Grundplatte des Ablagemechanismus eingepaßt ist.
9. Vorrichtung nach einem der Ansprüche 6 bis 8, dadurch **gekennzeichnet**, daß zur Beförderung der Ablagemechanismen zum Drehteller ein Förderband vorgesehen und in der Nähe des Endes dieses Förderbandes eine Schubeinrichtung angeordnet ist, wobei die Mechanismen durch diese Schubeinrichtung von diesem Band und in Richtung des Drehtellers bewegt werden können.
10. Vorrichtung nach Anspruch 9, dadurch **gekennzeichnet**, daß Oberhalb des Förderbandes Stopper vorgesehen sind, wobei diese Stopper zwischen einer ersten Position, in der die Stopper in der Bewegungsbahn der Ablagemechanismen liegen, und einer zweiten Position hin und her bewegt werden können, in der die Stopper außerhalb der Bewegungsbahn der Ablagemechanismen liegen.
11. Vorrichtung nach Anspruch 10, dadurch **gekennzeichnet**, daß die beiden Stopper mit den Enden eines Hebels verbunden sind, der durch den Rahmen schwenkbar zwischen seinen Enden gehalten wird, und der durch die Stelleinrichtung hin und her schwenkbar ist.
12. Vorrichtung nach einem der Ansprüche 9 bis 11, dadurch **gekennzeichnet**, daß in der Nähe des stromaufwärtigen Endes des Förderbandes eine Umschalteneinrichtung vorgesehen ist, die zwischen einer ersten Position, in der die dem Förderband zugeführten Ablagemechanismen durch das Förderband in Richtung des Drehtellers bewegt werden können, und einer zweiten Position einstellbar ist, in der die zugeführten Ablagemechanismen durch diese Umschalteneinrichtung seitlich von diesem Band abgegeben werden.
13. Vorrichtung nach einem der Ansprüche 1 bis 3 zum Auseinandersortieren der Verpackungseinheiten, dadurch **gekennzeichnet**, daß diese Vorrichtung mit einem Beschickungsband versehen ist, um die Verpackungseinheiten der Aufnahmeeinrichtung zuzuführen, wobei an der Seite des Beschickungsbandes, die von der Aufnahmeeinrichtung entfernt ist, eine Schubeinrichtung vorgesehen ist, um die Verpackungseinheiten gegeneinander geschwenkt in die Aufnahmeeinrichtung zu bewegen.
14. Vorrichtung nach Anspruch 13, dadurch **gekennzeichnet**, daß an der Abgabeseite der Aufnahmeeinrichtung ein weiteres Förderband vorgesehen ist, durch das die paarweise angeordneten Ablagemechanismen in Richtung der Drehteller geschickt werden können, die an einer Seite des Förderbandes angeordnet sind, wobei an der anderen Seite des Förderbandes Schubeinrichtungen angeordnet sind, durch die die paarweise angeordneten Ablagemechanismen auf die Drehteller bewegt werden können.
15. Vorrichtung nach Anspruch 14, dadurch **gekennzeichnet**, daß stromaufwärts der Schubeinrichtungen, die mit dem Drehteller in Wechselwirkung stehen, in Bewegungsrichtung des die Mechanismen bewegenden Förderbandes gesehen, weitere Schubeinrichtungen angeordnet sind, durch die Ablagemechanismen ebenfalls vom Förderband geschoben werden können.

16. Vorrichtung nach Anspruch 13, dadurch **gekennzeichnet**, daß die Drehteller auf der Abgabeseite der Aufnahmeeinrichtung vorgesehen sind, wobei diese Drehteller zwischen der Aufnahmeeinrichtung und der Beförderungseinrichtung hin und her beweglich angeordnet sind, von wo die Ablagemechanismen der Abgabeeinrichtung zugeführt werden können.

Revendications

1. Dispositif pour l'assemblage (dégagement) d'une unité d'emballage constituée par quatre mécanismes à anneaux dotés d'une plaque d'embase et d'une paire d'arceaux et d'un levier d'actionnement pour l'ouverture et la fermeture des arceaux, le dispositif étant muni d'une paire d'éléments de réception sur chacun desquels une paire de mécanismes d'anneaux, alignés peuvent être placés avec leur plaque d'embase tandis que des moyens ont été prévus pour mettre en pivotement les deux éléments de réception l'un par rapport à l'autre entre une première position de placement (évacuation) des mécanismes à anneaux sur (à partir de) les éléments de réception et une seconde position dans laquelle les mécanismes à anneaux sont enfermés entre les éléments de réception avec leurs arceaux déplacés entre eux.

2. Dispositif selon la revendication 1, caractérisé en ce que les éléments de réception sont munis d'embrèvements pour loger des bords longitudinaux des plaques d'embase des mécanismes à anneaux.

3. Dispositif selon les revendications 1 ou 2, caractérisé en ce que des systèmes de réglage ou d'ajustement sont prévus au moyen desquels les mécanismes à anneaux peuvent se déplacer par rapport aux éléments de réception à la fois dans la première position et dans la seconde position des éléments de réception.

4. Dispositif pour l'assemblage des unités d'emballage selon l'une quelconque des revendications précédentes, caractérisé en ce que le dispositif est muni d'au moins un transporteur au moyen duquel des mécanismes à anneaux disposés par paires sont amenés sur les moyens de réception, des moyens de poussée étant disposés à proximité des éléments de réception sur le côté du transporteur éloigné du système de réception, au moyen desquels systèmes de poussée on peut placer les mécanismes à anneaux sur les éléments de réception.

5

10

15

20

25

30

35

40

45

50

55

5. Dispositif selon la revendication 4, caractérisé en ce que le transporteur est muni de butées faisant saillie au-dessus du plan du transporteur entre lesquelles s'adaptent les plaques d'embase des mécanismes à anneaux.

6. Dispositif selon les revendications 4 ou 5, caractérisé en ce qu'en amont du transporteur vu dans le sens de déplacement du transporteur, il est prévu une table rotative sur laquelle sont amenés les mécanismes à anneaux un par un et au moyen de laquelle les mécanismes à anneaux peuvent être mis en pivotement alternativement à 180°.

7. Dispositif selon l'une quelconque des revendications 4 - 6, caractérisé en ce que le transporteur peut se déplacer en pas en pas.

8. Dispositif selon les revendications 6 ou 7, caractérisé en ce que sur le côté supérieur, la table rotative est munie d'un évidement dans lequel s'adapte une plaque d'embase d'un mécanisme à anneaux.

9. Dispositif selon l'une quelconque des revendications 6 - 8, caractérisé en ce que pour l'acheminement des mécanismes à anneaux sur la table rotative, il est prévu une bande transporteuse et il est agencé un système de poussée à proximité de l'extrémité de la bande transporteuse au moyen duquel système de poussée les mécanismes peuvent être déplacés à partir de la bande transporteuse et dans la direction de la table rotative.

10. Dispositif selon la revendication 9, caractérisé en ce que des butées sont prévues au-dessus de la bande transporteuse, lesquelles butées peuvent être déplacées en va-et-vient entre une première position dans laquelle les butées se situent dans la trajectoire du mouvement des mécanismes d'anneaux et une seconde position dans laquelle les butées se situent hors de la trajectoire du mouvement des mécanismes à anneaux.

11. Dispositif selon la revendication 10, caractérisé en ce que les deux butées sont accouplées aux extrémités d'un levier qui est monté de façon pivotante entre ces extrémités par le châssis et qui peut être mis en pivotement de va-et-vient au moyen d'un système de réglage.

12. Dispositif selon l'une quelconque des revendications 9 - 11 caractérisé en ce qu'à proximité de l'extrémité amont de la bande transporteuse, il est prévu un système de permutation qui est réglable entre une première position dans laquelle

les mécanismes à anneaux amenés à la bande transporteuse peuvent être déplacés dans la direction de la table rotative au moyen de la bande transporteuse et une seconde position dans laquelle les mécanismes à anneaux acheminés sont déchargés latéralement de la bande transporteuse au moyen d'un système de transfert.

5

- 13.** Dispositif selon l'une quelconque des revendications 1 - 3 destiné à dégager les unités d'emballage caractérisé en ce que le dispositif est muni d'une bande transporteuse d'acheminement pour amener les unités d'emballage sur les systèmes de réception, un système de poussée étant prévu sur le côté de la bande transporteuse d'alimentation éloignée du système de réception, pour déplacer les unités d'emballage sur les moyens de réception mis en pivotement l'un vers l'autre.

10

15

20

- 14.** Dispositif selon la revendication 13, caractérisé en ce que sur le côté d'évacuation du système de réception, il est prévu une bande transporteuse supplémentaire au moyen de laquelle des mécanismes à anneaux disposés par paires peuvent être acheminés dans la direction des tables rotatives qui sont disposées sur un côté de la bande transporteuse tandis que sur l'autre côté de la bande transporteuse sont agencés des systèmes de poussée au moyen desquels les mécanismes à anneaux disposés par paires peuvent être déplacés sur les tables rotatives.

25

30

- 15.** Dispositif selon la revendication 14, caractérisé en ce qu'en amont des systèmes de poussée coopérant avec la table rotative, vu dans la direction de déplacement de la bande transporteuse acheminant les mécanismes, il est prévu des systèmes de poussée supplémentaires au moyen desquels les mécanismes à anneaux peuvent être également poussés à partir de la bande transporteuse.

35

40

- 16.** Dispositif selon la revendication 13, caractérisé en ce que les tables rotatives sont prévues sur le côté de déchargement du système de réception, lesquelles tables rotatives sont disposées entre les systèmes de réception et un système de transporteur pouvant se déplacer en va-et-vient à partir duquel les mécanismes à anneaux peuvent être acheminés sur un système d'évacuation.

45

50

55

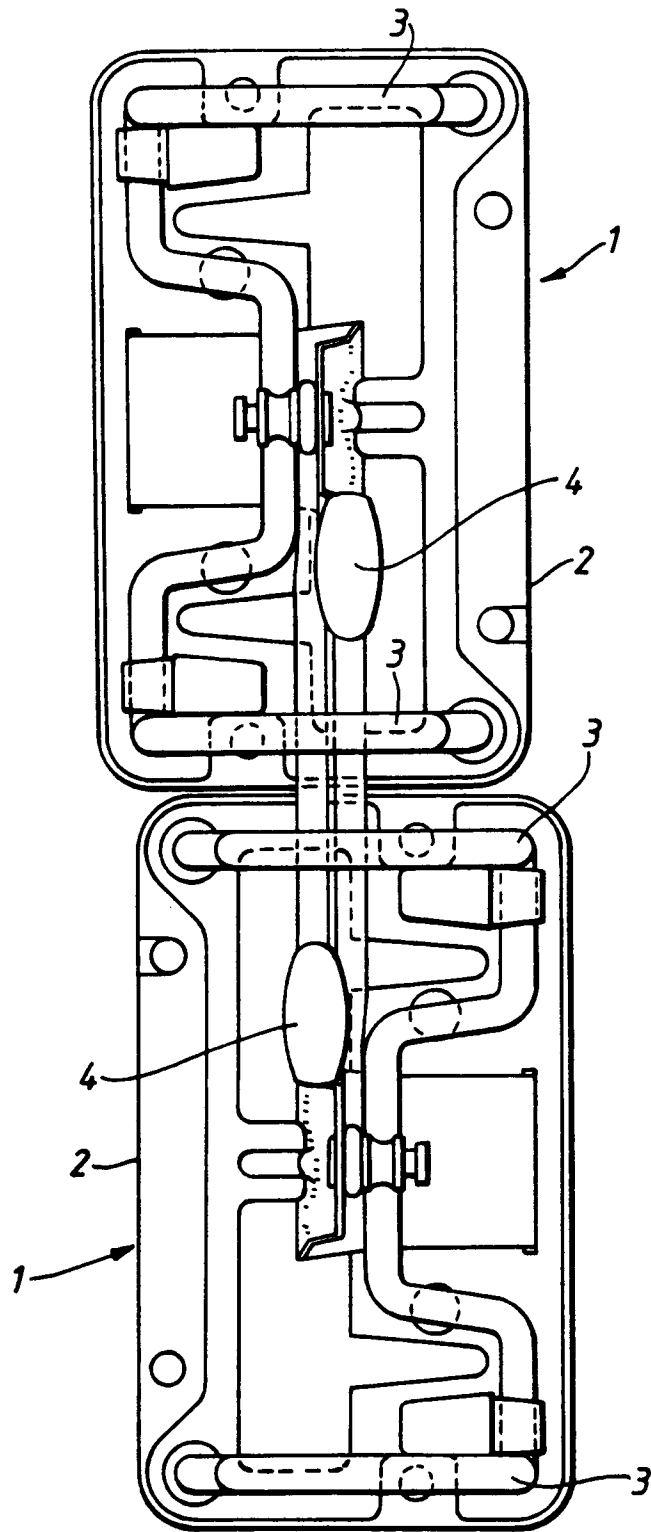

FIG. 1.

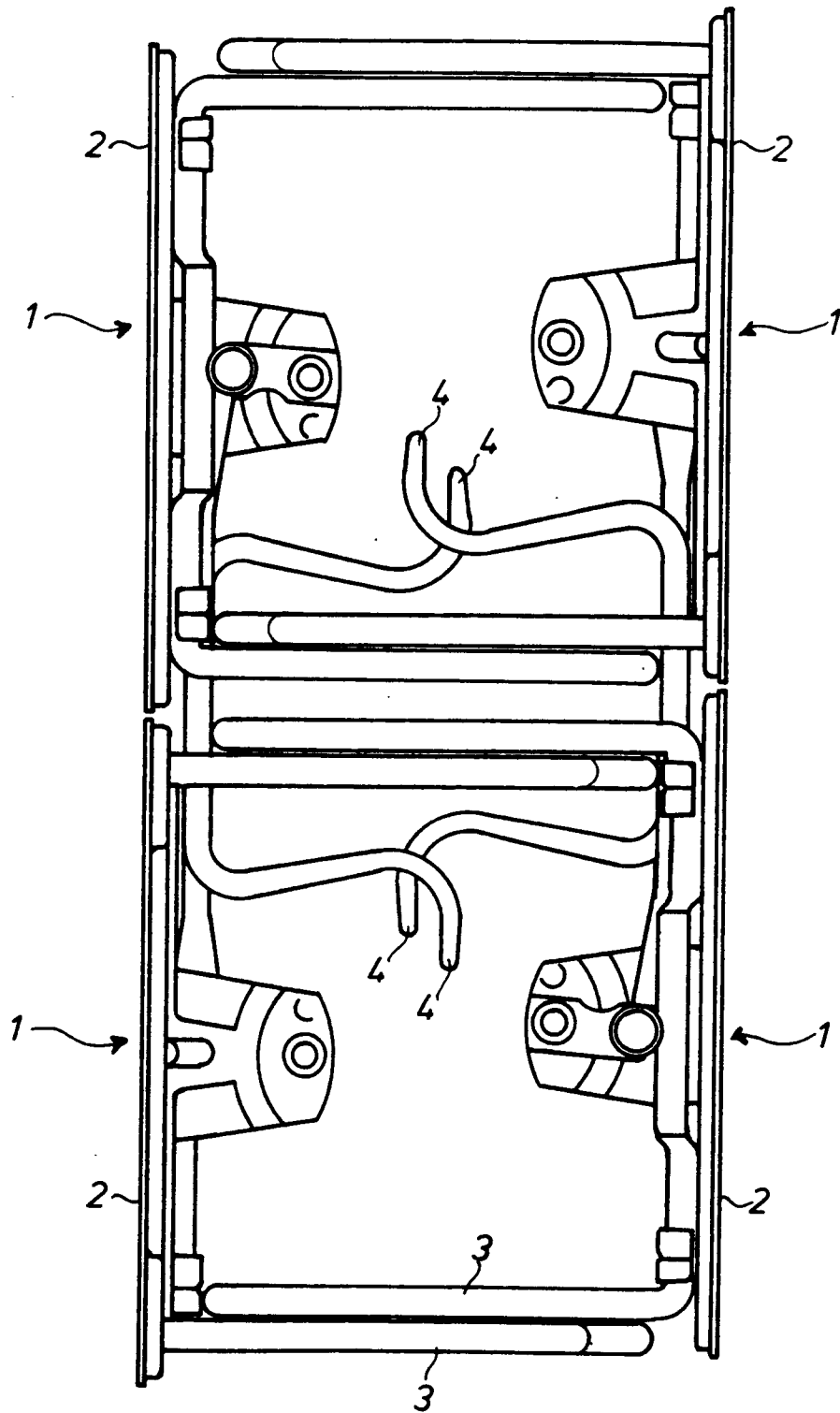

FIG. 2

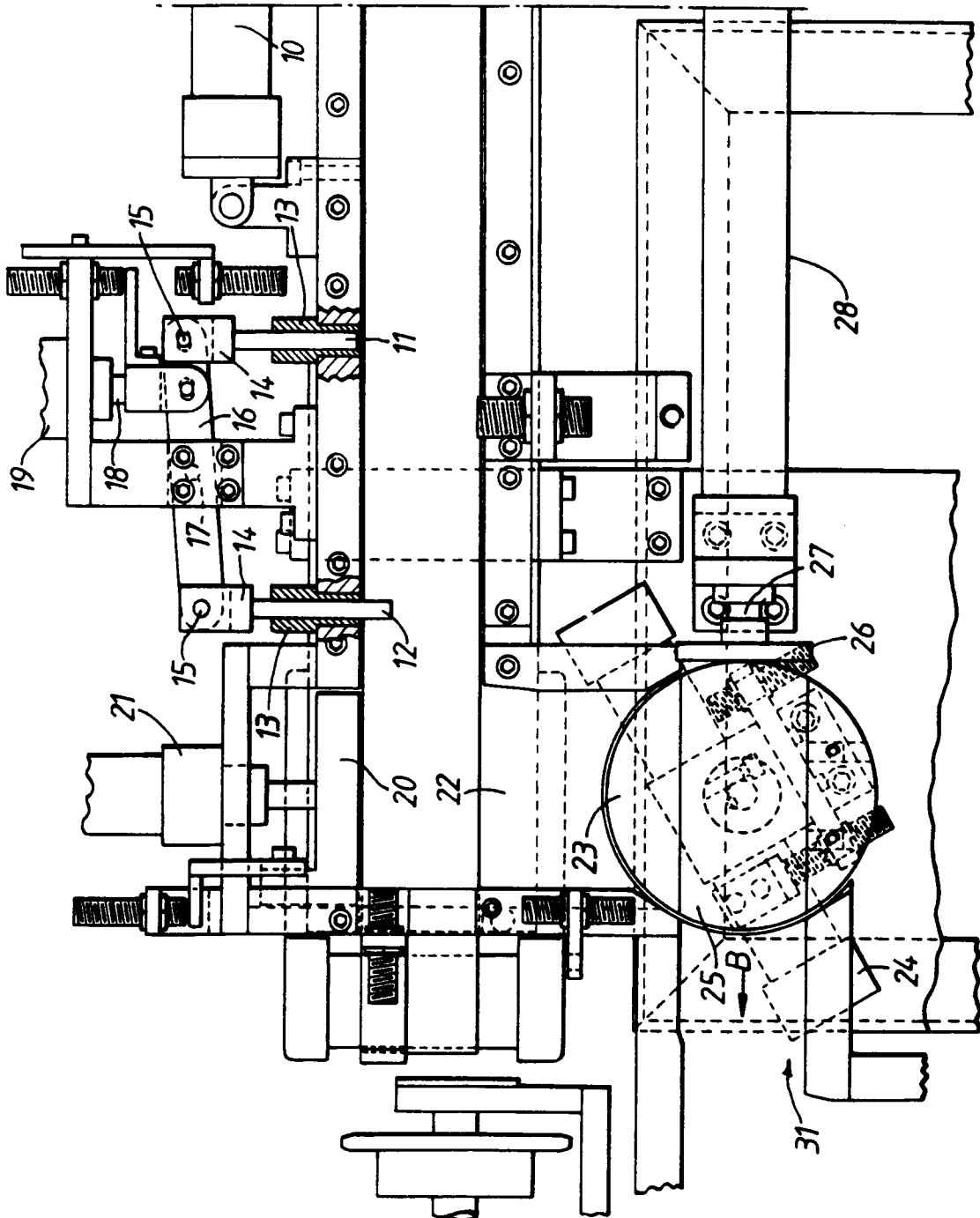
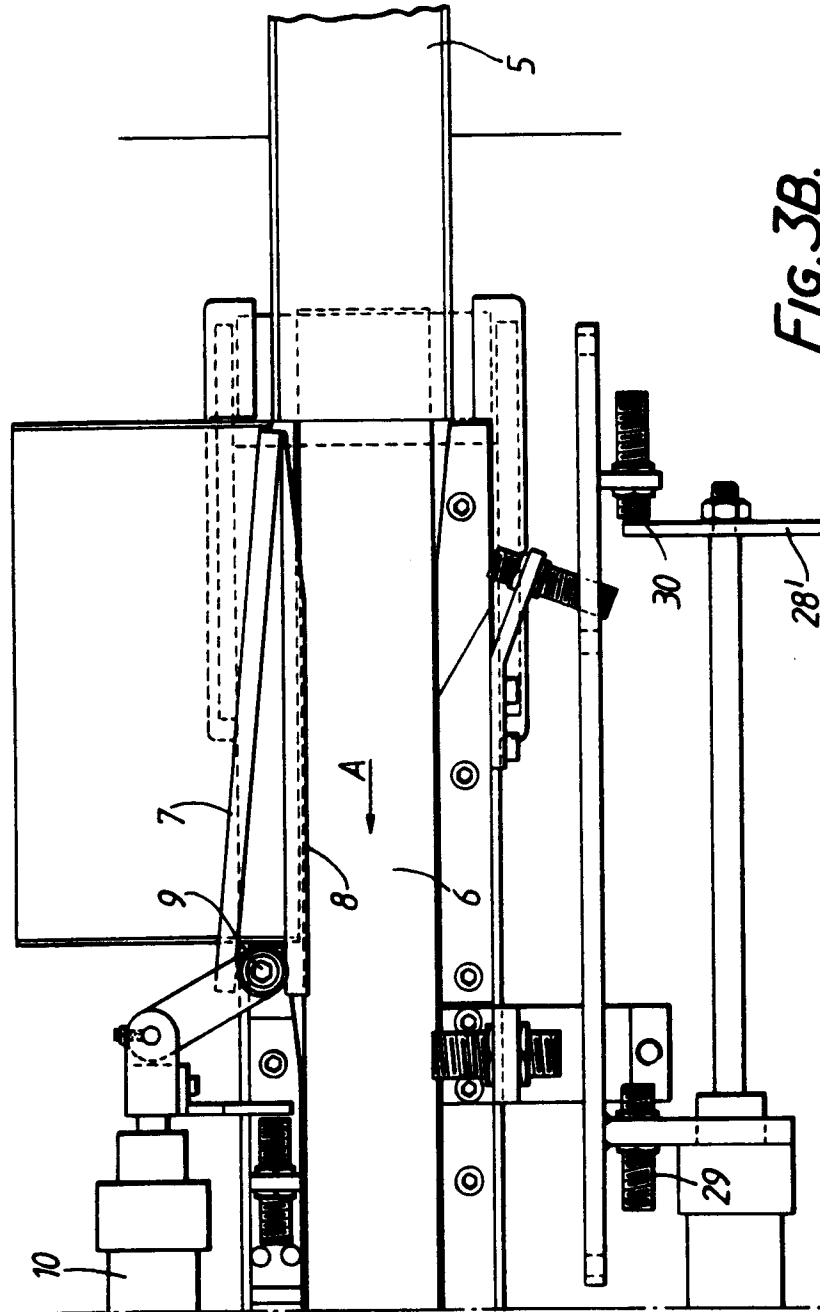

FIG. 3A.



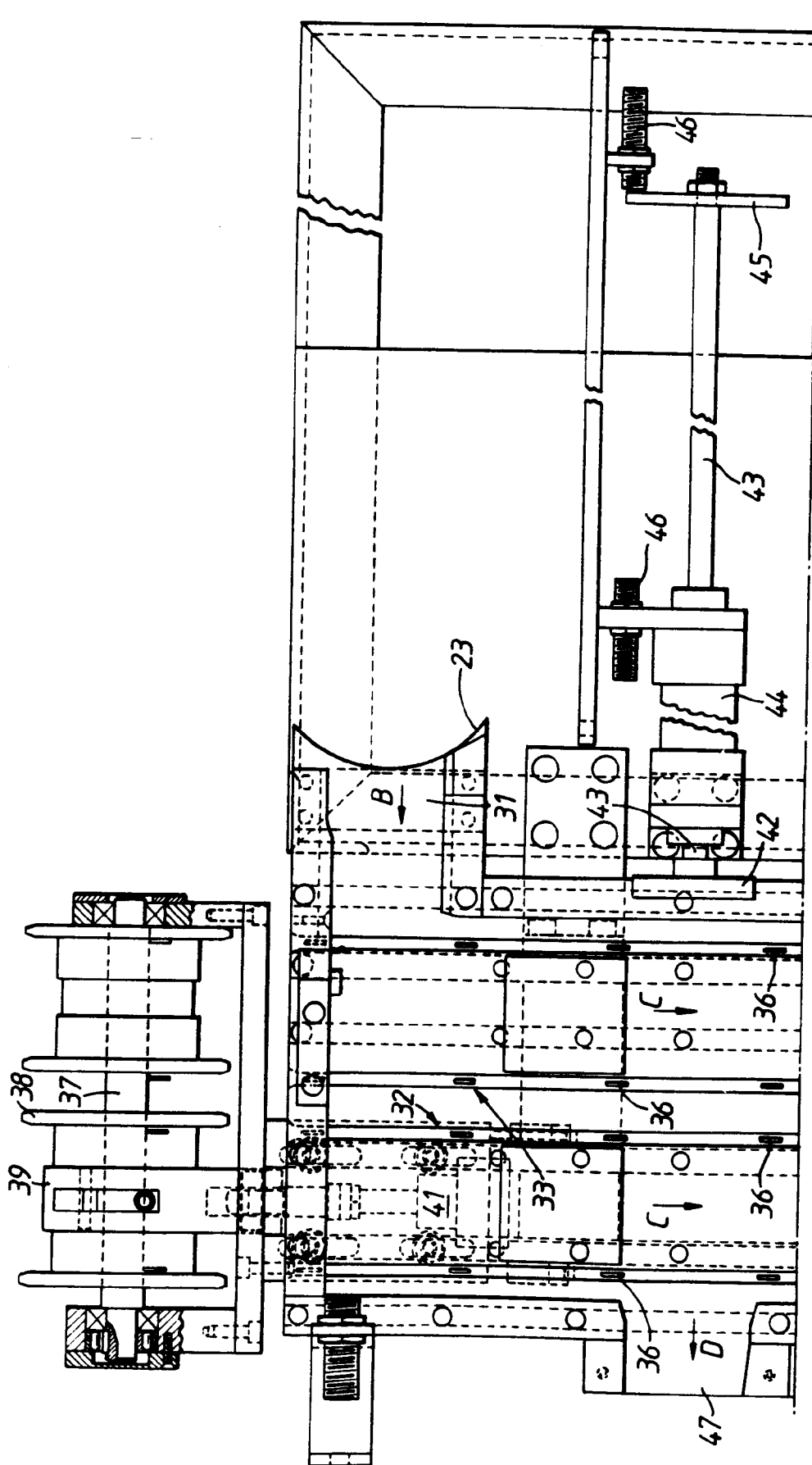

FIG. 4A.

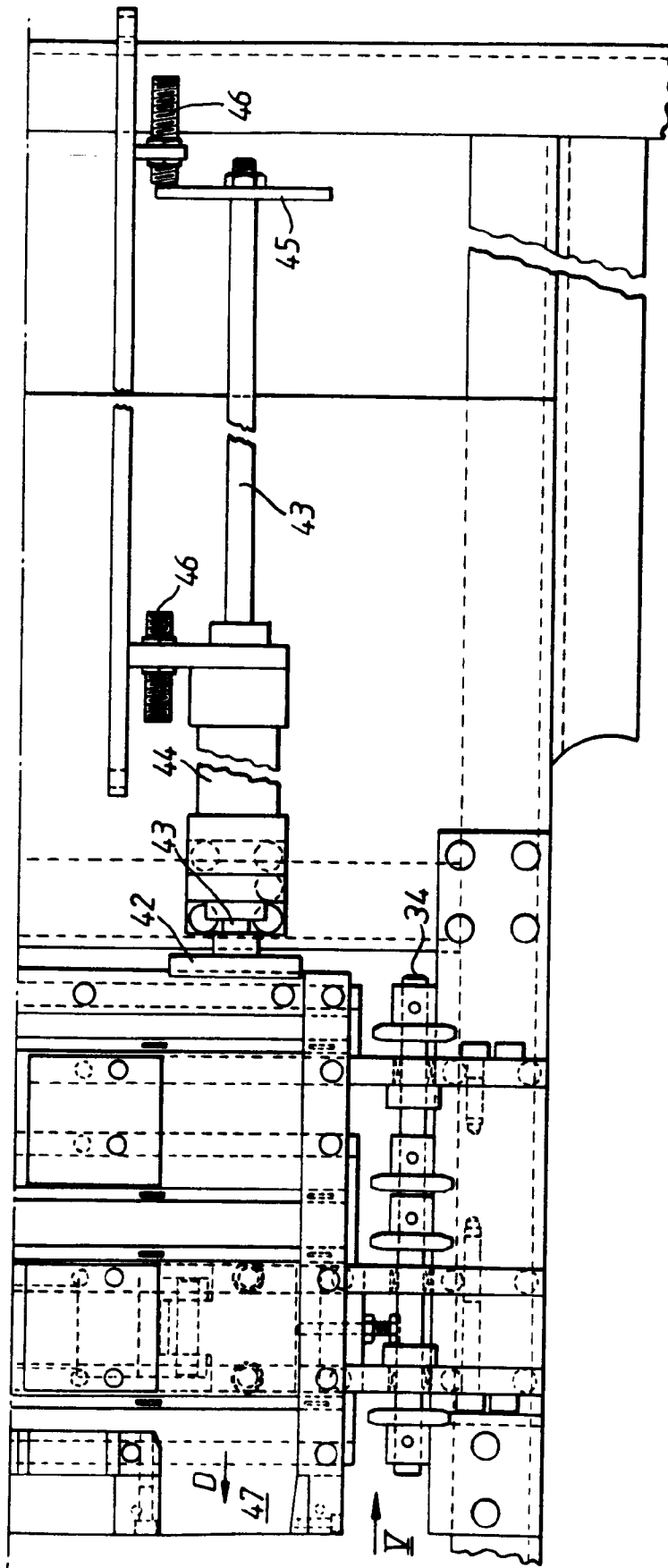

FIG. 4B.

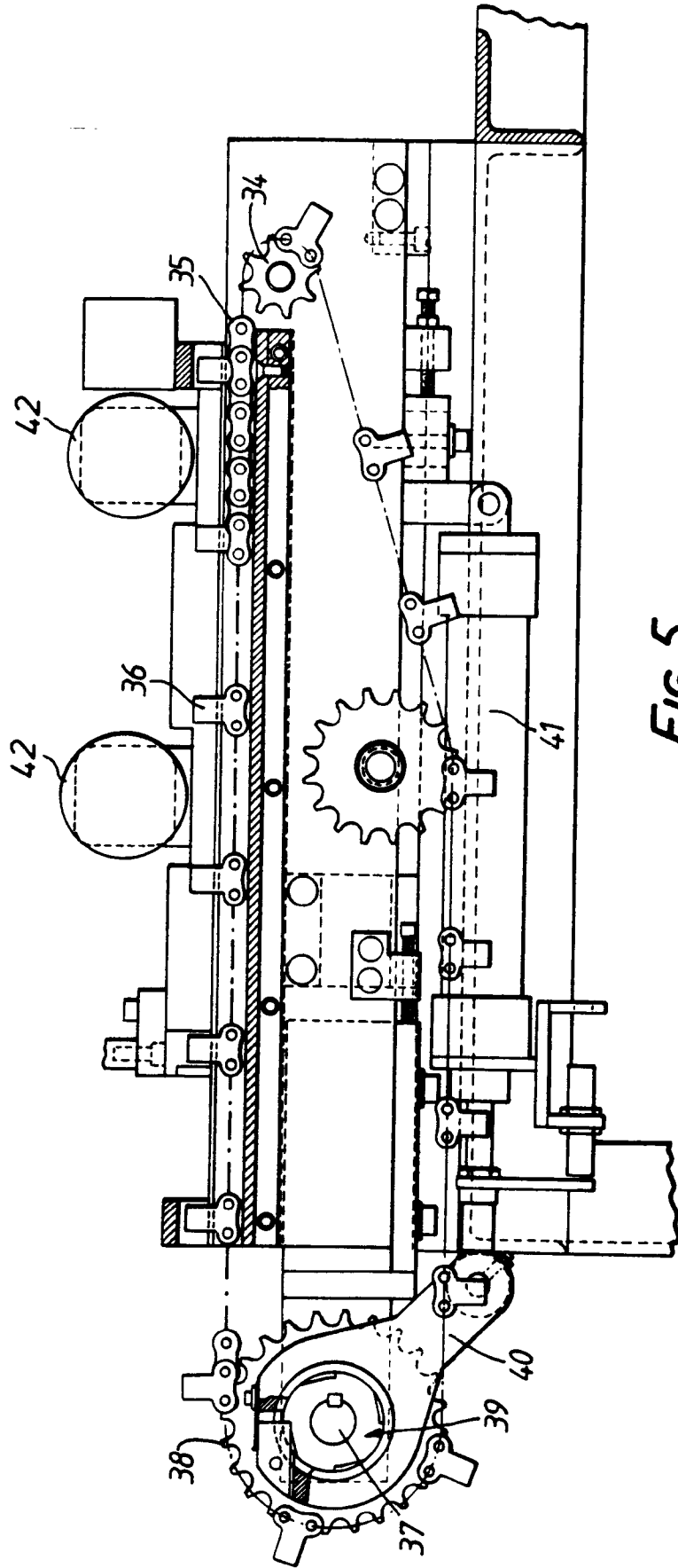
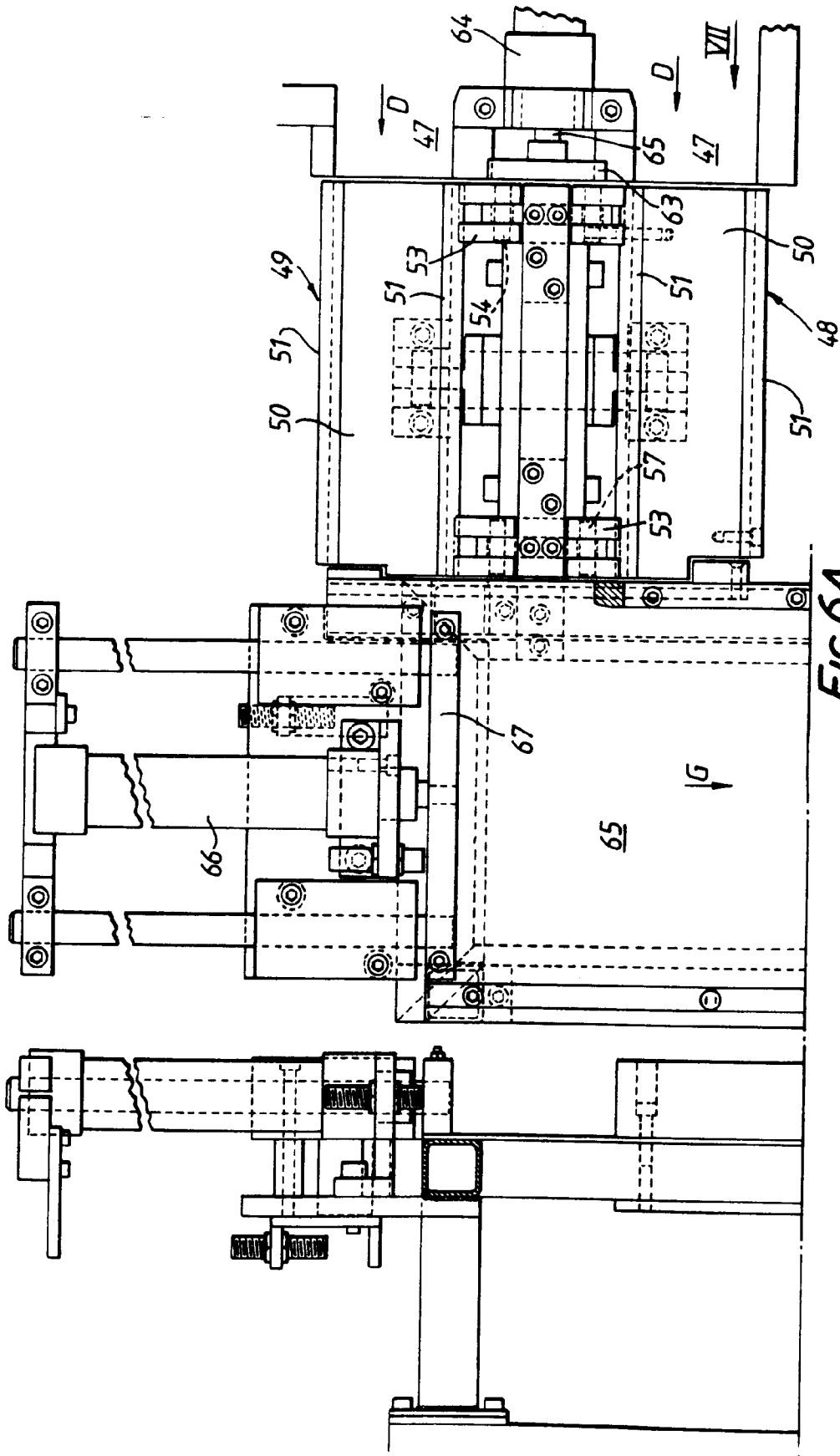
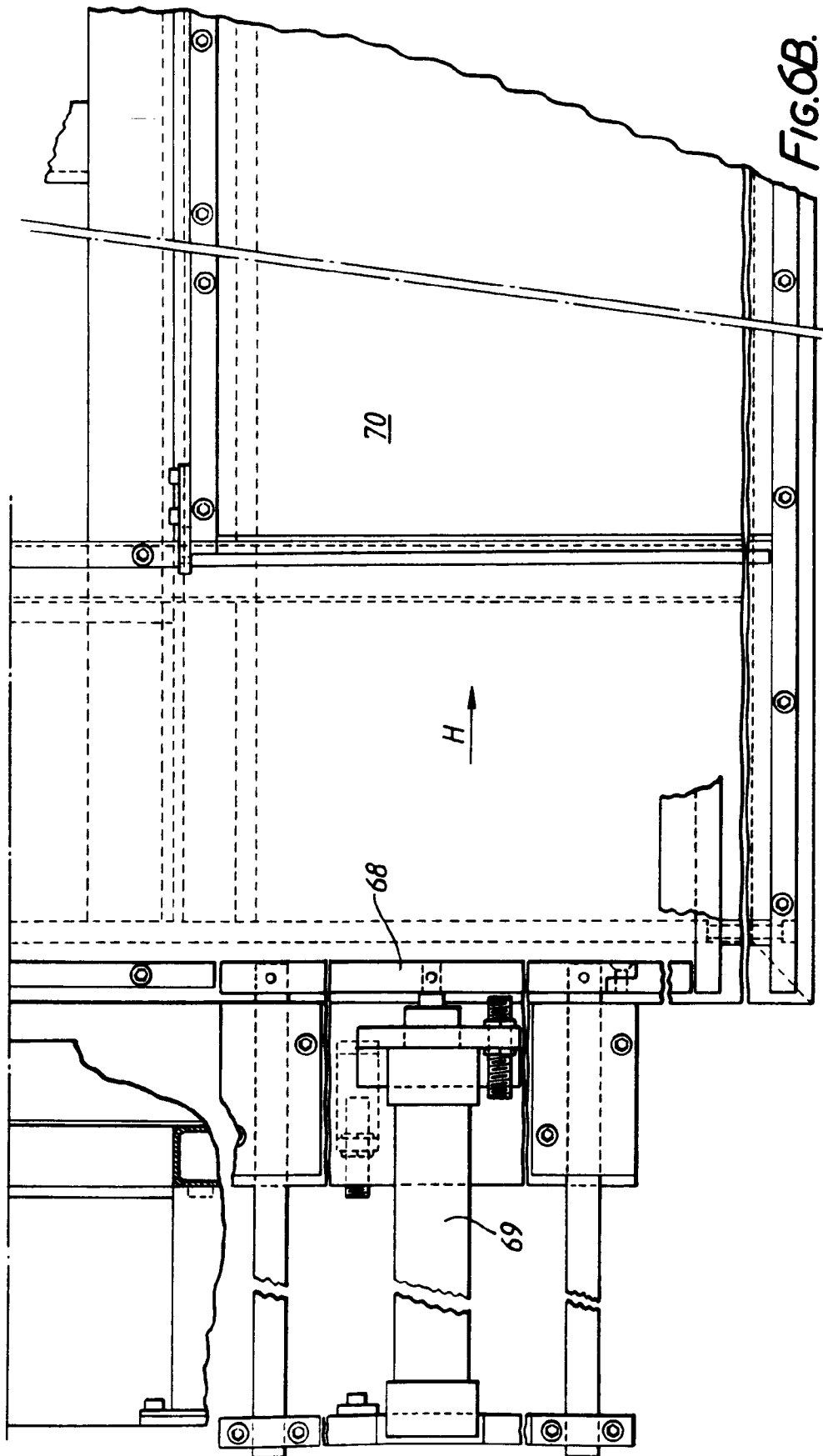

FIG. 5.





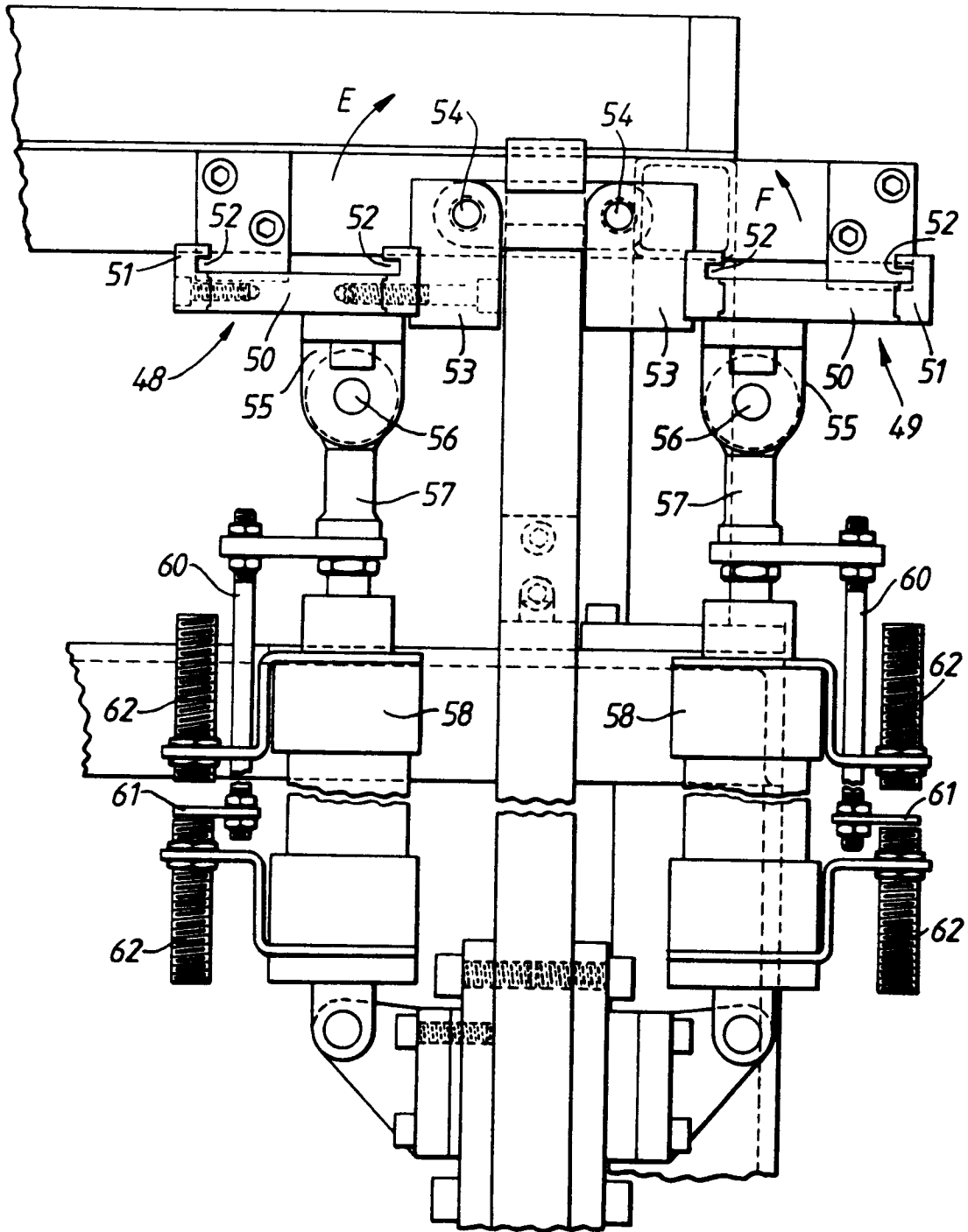

FIG. 7.

FIG. 8

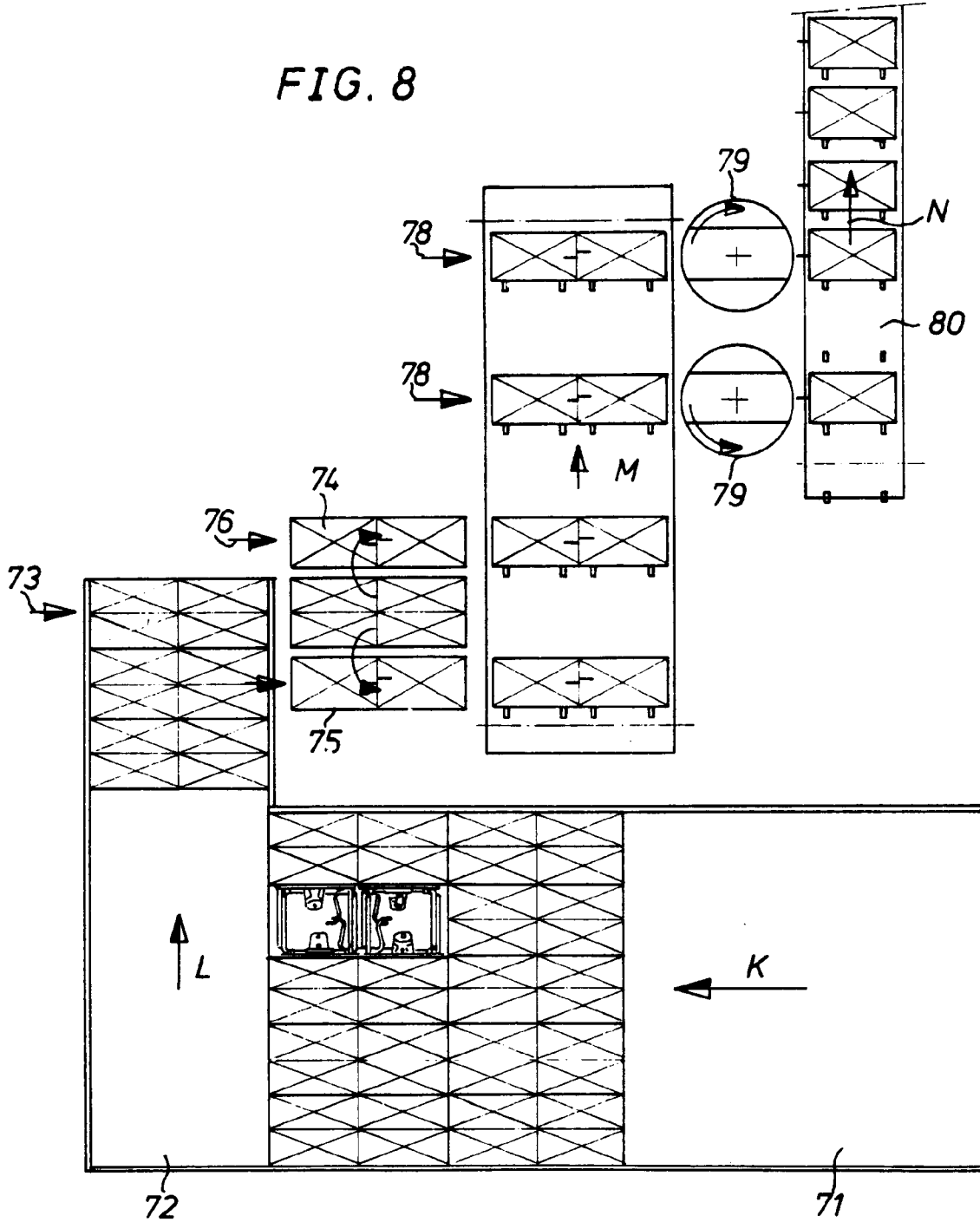

FIG. 9

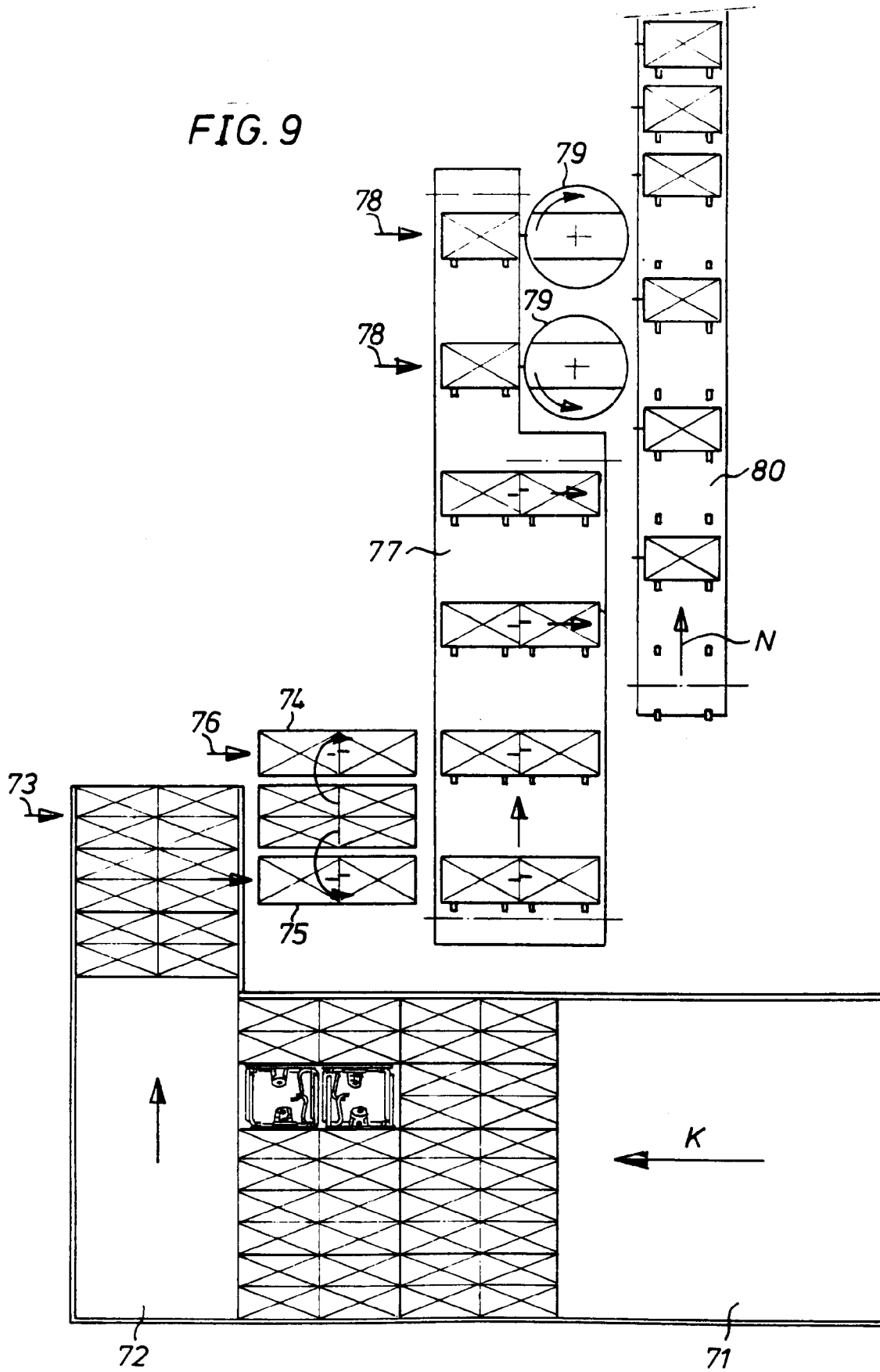

FIG. 10

