



12

EUROPEAN PATENT SPECIFICATION

45 Date of publication of patent specification :
31.07.91 Bulletin 91/31

51 Int. Cl.⁵ : **E04H 3/12**

21 Application number : **89301016.5**

22 Date of filing : **02.02.89**

54 **Stepped floor moving apparatus for movable stand.**

30 Priority : **17.03.88 JP 34528/88**

43 Date of publication of application :
18.10.89 Bulletin 89/42

45 Publication of the grant of the patent :
31.07.91 Bulletin 91/31

84 Designated Contracting States :
DE FR GB NL

56 References cited :
DE-A- 2 935 440
DE-A- 3 013 493
DE-A- 3 013 530
FR-A- 2 485 602
US-A- 3 400 502

73 Proprietor : **OKAMURA CORPORATION**
7-18 Kitasaiwai 2-chome Nishi-ku
Yokohama-shi Kanagawa-ken (JP)

72 Inventor : **Mitsumoto, Takayasu**
1-26-5, Take
Yokosuka-Shi Kanagawa-Ken (JP)
Inventor : **Shimomura, Tsuneo**
45-6, Nokendai-dori Kanazawa-Ku
Yokohama-Shi Kanagawa-Ken (JP)
Inventor : **Sato, Junnosuke**
3-1-10, Tomioka-Nishi Kanazawa-Ku
Yokohama-Shi Kanagawa-Ken (JP)

74 Representative : **Geldard, David Guthrie et al**
URQUHART-DYKES AND LORD Tower House
Merrion Way
Leeds West Yorkshire LS2 8PA (GB)

EP 0 337 592 B1

Note : Within nine months from the publication of the mention of the grant of the European patent, any person may give notice to the European Patent Office of opposition to the European patent granted. Notice of opposition shall be filed in a written reasoned statement. It shall not be deemed to have been filed until the opposition fee has been paid (Art. 99(1) European patent convention).

Description

BACKGROUND OF THE INVENTION

1) Field of the Invention

This invention relates to a stepped floor moving apparatus for a movable stand wherein a plurality of stepped floors can be collapsed in a telescopic manner.

2) Description of the Prior Art

A movable stand for a multi-purpose hall and so on is already known wherein a plurality of stepped floors are collapsed or accommodated successively below the adjacent rear stepped floors when they are not used, but when they are to be used, they are extended forwardly into a stair-like configuration and then collapsed chairs on each of the stepped seats are pulled up to complete the stand for use.

A mechanism for moving stepped floors of such a telescopic type is disclosed, for example, in Japanese Patent Application No. 61-121000 entitled "Movable Stand" and filed by the applicant of the present patent application. The mechanism is shown in Fig. 5.

Referring to Fig. 5, the mechanism includes a wire (c) having a front end secured to a frontmost stepped floor (a) and a rear end secured to and wound around a drum (b). As the wire (c) is taken up onto the drum (b) stepped floors are successively accommodated into a rearmost stepped seat (d). To the contrary, in order to extend the stepped floors forwardly into a stair-like configuration, another wire (g) is taken up onto the drum (b). The wire (g) has a front end secured to the frontmost stepped floor (a) and a rear end secured to and wound around the drum (b) and extending past a plurality of fixed pulleys (e) and (f) mounted at rear portions of the stepped floors and at lower faces of the individually adjacent rear stepped floors, respectively.

Each of the stepped floors is moved on a floor (i) by means of a plurality of wheels (h), and the opposite sides of a rear portion of each of the stepped floors are guided by an adjacent rear one of the stepped floors. Accordingly, there is a drawback that the stepped floors are apt to move in a zigzag direction when they are extended.

In order to resolve the drawback, a parallel guide apparatus for a movable stand of the telescopic type is provided wherein a pair of right and left gears which are held in meshing engagement with racks are rotated at the same speed to move each of a plurality of stepped floors straightforwardly. Such an apparatus is disclosed, for example, in Japanese Utility Model Laid-Open Pub. No. 61-127255.

With the parallel guide apparatus, however, reliable meshing engagement between racks and gears

cannot be attained readily because a stand is normally composed of a large number of channel bars assembled by welding or the like and accordingly variations of tolerance and distortion or the like of a frame cannot be eliminated.

SUMMARY OF THE INVENTION

It is an object of the present invention to provide an apparatus for a movable stand which can assure straightforward movement of a stepped floor with respect to another stepped floor of the movable stand when the former stepped floor is moved.

In order to attain the object, according to the present invention, there is provided an apparatus for moving a stepped floor straightforwardly with respect to another stepped floor in a movable stand wherein the former stepped floor and the latter stepped floor are associated with each other such that, when the movable stand is not used, the former stepped floor is accommodated in a telescopic manner below the latter stepped floor, but when the movable stand is to be used, the former stepped floor is pulled out of the latter stepped floor and extended forwardly into a stair-like configuration, characterized in that it comprises a pair of sprocket wheel trains mounted at locations on a pair of opposite left- and right-hand side walls adjacent a rear end of the former stepped floor and each including a follower sprocket wheel and a pair of guide sprocket wheels, a connecting shaft having the follower sprocket wheels mounted for integral rotation thereon, and a pair of chains extending substantially in parallel to each other and having one ends secured to the opposite left and right end portions of a front wall of the latter stepped floor and the other ends secured to the opposite left and right end portions of a rear wall of the latter stepped floor, the chains extending around and between the follower sprocket wheels and the guide sprocket wheels of the sprocket wheel trains on the former stepped floor.

With the apparatus, the former stepped floor is guided in a parallel relationship by the left and right chains when it is moved with respect to the latter stepped floor. Accordingly, during movement of the former stepped floor, it can advance or retreat straightforwardly without being oscillated leftwardly or rightwardly, which will prevent collision of the stepped floors with each other and assure smooth movement of the former stepped floor.

Where the movable stand includes three or more stepped floors, the apparatus according to the present invention may be provided between each adjacent ones of the stepped floors.

Preferably, the follower sprocket wheel of each of the sprocket wheel trains is disposed below and between the guide sprocket wheels, and an associated one of the chains extends in a substantially inverted Ω -shape along the follower sprocket wheel and the

guide sprocket wheels. The apparatus can thus be applied even to stepped floors which include a reinforcing beam mounted on a lower face of a central portion thereof and extending in the forward and backward direction.

A specific embodiment of the present invention will now be described in detail by way of example with reference to the accompanying drawings.

BRIEF DESCRIPTION OF THE DRAWINGS

Fig. 1 is a plan view, partly in section, of a movable stand in which a stepped floor moving apparatus according to the present invention is incorporated ;

Fig. 2 is a vertical sectional view taken along the center line in Fig. 1 ;

Fig. 3 is an enlarged vertical sectional view showing a train of sprocket wheels shown in Fig. 2 ;

Fig. 4 is a sectional view taken along line IV-IV of Fig. 3 ; and

Fig. 5 is a schematic side elevational view showing a conventional movable stand.

DETAILED DESCRIPTION OF THE ILLUSTRATED EMBODIMENT

Referring first to Figs. 1 and 2, a movable stand 1 is composed of a plurality of stepped floors including a first or frontmost stepped floor 2, second and third stepped floors 3 and 4 located rearwardly of the stepped floors 2 and 3, respectively, and a fourth or rear-most stepped floor (not shown) located rearwardly of the third stepped floor 3. Each of the stepped floors 2, 3 and 4 is smaller in width and height than an adjacent stepped floor on the rear side thereof.

The stepped floors 2, 3 and 4 are associated with each other such that, when the movable stand 1 is not used, the stepped floors 2, 3 and 4 are accommodated successively in a telescopic manner under the rearmost stepped floor, but when the movable stand 1 is to be used, the stepped floors 2, 3 and 4 are extended forwardly into a stair-like configuration. The stepped floors 2, 3 and 4 are driven to move by driving means (not shown).

The mechanism for moving the stepped floors 2, 3 and 4 may be similar in construction to the mechanism shown in Fig. 5. Accordingly, description of the mechanism is omitted herein to avoid redundancy, and only a stepped floor moving mechanism according to the present invention will be described herein.

The frontmost stepped floor 2 has a box-like configuration which is open at the bottom thereof and includes a base plate 2a, a pair of front and rear plates 2b and 2c extending downwardly from the opposite front and rear edges of the base plate 2a, and a pair of left-and right-hand side plates 2d extending downwardly from the opposite left-and right-hand side

edges of the base plate 2a.

Similarly, the second stepped floor 3 includes a base plate 3a, and a pair of front and rear plates 3b and 3c and a pair of side plates 3d extending downwardly from the base plate 3a while the third stepped floor 4 includes a base plate 4a, and a pair of front and rear plates 4b and 4c and a pair of side plates 4d extending downwardly from the base plate 4a.

Each of the first and second stepped floors 2 and 3 has a pair of left and right vertical mounting plates 5 provided at and extending rearwardly from upper portions of the opposite side edges of the rear plate 2c or 3c thereof.

Referring also to Figs. 3 and 4, a pair of shafts 6 and 7 are mounted in a predetermined spaced relationship at locations near an upper edge on an inner face of each of the mounting plates 5. A pair of guide sprocket wheels 8 and 9 are supported for rotation on the shafts 6 and 7, respectively.

A horizontal connecting shaft 10 is supported for rotation on and extends between a pair of bearings 10a mounted at locations between and below the front and rear guide sprocket wheels 8 and 9 on the left and right opposing mounting plates 5 of each of the stepped floors 2 and 3. A pair of follower sprocket wheels 11 are mounted for integral rotation at locations near the opposite left and right ends of the connecting shaft 10.

In Fig. 3, a left-hand side roller chain 12 is shown. The roller chain 12 shown has a front end portion 12a secured to a lower portion at the left end of a rear face of the front plate 3b of the stepped floor 3. An intermediate portion 12b of the roller chain 12 extends in a substantially inverted Ω -shape as viewed in side elevation around and between the guide sprocket wheel 8, follower sprocket wheel 11 and guide sprocket wheel 9, and a rear end portion of the roller chain 12 is secured to a front face of the rear plate 3c of the stepped floor 3.

Referring to Figs. 1 and 2, a right-hand side roller chain 13 is disposed in a symmetrical relationship to the left-hand side roller chain 12 and thus has a rear end portion 13a, an intermediate portion 13b and a rear end portion disposed in a similar manner to the corresponding ones of the left-hand side roller chain 12.

A similar mechanism is provided for the second stepped floor 3. In particular, a pair of sprocket wheel trains each including a pair of guide sprocket wheels 8 and 9 and a follower sprocket wheel 11 are mounted on the left and right mounting plates 5 of the second stepped floor 3, and a pair of left-and right-hand side roller chains 12 and 13 are secured at the opposite ends thereof to the third stepped floor 4 and extend in parallel to each other along the sprocket wheel trains on the second stepped floor 3. The follower sprocket wheels 11 are mounted for integral rotation on a connecting shaft 10.

Operation of the stepped floor moving apparatus will be described by way of example of the stepped floor 2.

When the movable stand 1 is in its accommodated condition, the stepped floors 2, 3 and 4 are positioned in a vertically overlapping relationship, and the sprocket wheel trains on the stepped floors 2, 3 and 4 are also positioned in a vertically overlapping relationship.

When the stepped floor 2 is pulled out and moved forwardly by the driving mechanism not shown, the left- and right-hand side sprocket wheel trains on the stepped floor 2 are moved forwardly while stroking the roller chains 12 and 13. In this instance, since the left and right sprocket wheels 11 are rotated in an integral relationship by means of the connecting link 10, a front end portion of the stepped floor 2 is advanced straightforwardly without being oscillated in the leftward or rightward direction.

Similarly, the stepped floor 3 is pulled out and advanced straightforwardly with respect to the adjacent stepped floor 4 on the rear side.

Claims

1. An apparatus for moving a stepped floor straightforwardly with respect to another stepped floor in a movable stand wherein the former stepped floor and the latter stepped floor are associated with each other such that, when said movable stand is not used, the former stepped floor is accommodated in a telescopic manner below the latter stepped floor, but when said movable stand is to be used, the former stepped floor is pulled out of the latter stepped floor and extended forwardly into a stair-like configuration, characterized in that it comprises a pair of sprocket wheel trains mounted at locations on a pair of opposite left- and right-hand side walls (2d, 3d) adjacent to the rear end of the former stepped floor (2, 3) and each including a follower sprocket wheel (11) and a pair of guide sprocket wheels (8, 9), a connecting shaft (10) having said follower sprocket wheels (8, 9) mounted for integral rotation thereon, and a pair of chains (12, 13) extending substantially in parallel to each other and having one ends (12a) secured to the opposite left and right end portions of a front wall (3b, 4b) of the latter stepped floor (3, 4) and the other ends secured to the opposite left and right end portions of a rear wall (3c, 4c) of the latter stepped floor (3, 4), said chains (12, 13) extending around and between said follower sprocket wheels (11) and said guide sprocket wheels (8, 9) of said sprocket wheel trains on the former stepped floor (2, 3).

2. An apparatus as set forth in claim 1, characterized in that, in each of said sprocket wheel trains, said follower sprocket wheel (11) is disposed below and between said guide sprocket wheels (8, 9), and

an associated one of said chains (12, 13) extends in a substantially inverted Ω -shape along said follower sprocket wheel (11) and said guide sprocket wheels (8, 9).

3. An apparatus as set forth in claim 1 or 2, characterized in that each of said chains (12, 13) is a roller chain.

4. An apparatus as set forth in any one of the preceding claims, characterized in that said sprocket wheel trains are mounted on a pair of left and right mounting plates (5) provided at and extending rearwardly from upper portions of the opposite side edges of the former stepped floor (2, 3).

Patentansprüche

1. Vorrichtung zur geradlinigen Bewegung eines Stufenbodens in Bezug auf einen anderen Stufenboden einer beweglichen Tribüne, bei der der erste Stufenboden und der zweite Stufenboden in der Weise einander zugeordnet sind, daß bei Nichtbenutzung der beweglichen Tribüne der erste Stufenboden teleskopisch unterhalb des zweiten Stufenbodens untergebracht ist, und zu Benutzung der beweglichen Tribüne der erste Stufenboden aus dem zweiten Stufenboden herausgezogen und nach vorne in eine Stufenförmige Anordnung gebracht wird, dadurch gekennzeichnet, daß die Vorrichtung ein Paar von Kettenradtrieben enthält, die an einem Paar von an gegenüberliegenden rechten und linken Seitenwänden (2d, 3d) am hinteren Ende des ersten Stufenbodens (2, 3) angeordnet sind, daß jeder Kettenradtrieb ein Nebenzahnrad (11) und ein Paar von Führungszahnradern (8, 9) enthält, daß die Nebenzahnräder (11) auf einer Verbindungswelle (10) zur integralen Drehung angeordnet sind und ein Paar von Ketten (12, 13) sich im wesentlichen parallel zueinander erstrecken, deren ein Ende (12a) an gegenüberliegenden linken und rechten Enden einer Vorderwand (3b, 4b) des zweiten Stufenbodens (3, 4) und die anderen Enden an gegenüberliegenden linken und rechten Enden einer Rückwand (3c, 4c) des zweiten Stufenbodens (3, 4) befestigt sind, wobei die Ketten (12, 13) um und zwischen den Nebenzahnrädern (11) und den Führungszahnradern (8, 9) der Kettenradtriebe des ersten Stufenbodens (2, 3) verlaufen.

2. Vorrichtung nach Anspruch 1, dadurch gekennzeichnet, daß in jedem der Kettenradtriebe das Nebenzahnrad (11) unterhalb und zwischen den Führungszahnradern (8, 9) angeordnet ist und die zugeordnete Kette (12, 13) in einer im wesentlichen Ω -förmigen Anordnung über das Nebenzahnrad (11) und die Führungszahnräder (8, 9) geführt ist.

3. Vorrichtung nach Anspruch 1 oder 2, dadurch gekennzeichnet, daß die Ketten (12, 13) Rollketten sind.

4. Vorrichtung nach einem oder mehreren der

vorhergehenden Ansprüche, dadurch gekennzeichnet, daß die Kettenradtriebe auf einem Paar von linken und rechten Montageplatten (5) angeordnet sind, die sich von oberen Enden gegenüberliegender Seitenkanten des ersten Stufenbodens (2, 3) nach hinten erstrecken.

5

Revendications

10

1. Dispositif pour le déplacement rectiligne d'un palier par rapport à un autre palier appartenant à un ensemble de gradins mobiles, dans lequel le premier palier et le second palier sont associés l'un à l'autre de telle façon que lorsque l'ensemble de gradins mobiles n'est pas en utilisation, le premier palier est ramené de façon télescopique en dessous du second palier, mais lorsque ledit ensemble de gradins doit être mis en position d'utilisation, le premier palier est tiré en dehors du second palier et il est mis en position d'extension vers l'avant en réalisant une conformation en escalier, caractérisé en ce qu'il comporte une paire de trains de pignons montés sur une paire de parois latérales respectivement droite et gauche (2d, 3d), voisines de l'extrémité arrière du premier palier (2, 3) et chaque train comporte un pignon asservi (11) et une paire de pignons de guidage (8, 9), un arbre (10) sur lesquels lesdits paliers asservis (11) sont montés en vue de leur rotation solidaire, et une paire de chaînes (12, 13) s'étendant sensiblement selon des parcours parallèles entre eux et ayant une extrémité (12a) solidaire respectivement des extrémités opposés droite et gauche d'une contremarche (3b, 4b) appartenant au second palier (3, 4) et les autres extrémités des dites chaînes étant solidaires des extrémités opposés respectivement droite et gauche de la paroi arrière (3c, 4c) du second palier (3, 4), lesdites chaînes (12, 13) s'étendant autour et entre ledit pignon asservi (11) et lesdits pignons de guidage (8, 9) du dit train de pignons du premier palier (2, 3).

15

20

25

30

35

40

2. Appareil selon la revendication 1, caractérisé en ce que, dans chacun des trains de pignons, ledit pignon asservi (11) est disposé en dessous et entre lesdits pignons de guidage (8, 9) et celle des chaînes (12, 13) qui lui est associée s'étend selon une configuration sensiblement en forme de Ω le long dudit pignon asservi (11) et desdits pignons de guidage (8, 9).

45

3. Appareil selon la revendication 1 ou la revendication 2, caractérisé en ce que chacune des chaînes (12, 13) est une chaîne à rouleaux.

50

4. Appareil selon d'une des revendications qui précèdent, caractérisé en ce que les dits trains de pignons sont montés sur une paire de joues (5) respectivement droite et gauche disposées et s'étendant vers l'arrière à partir des parties supérieures des côtés opposés des premiers paliers (2, 3).

55

5

FIG. 3

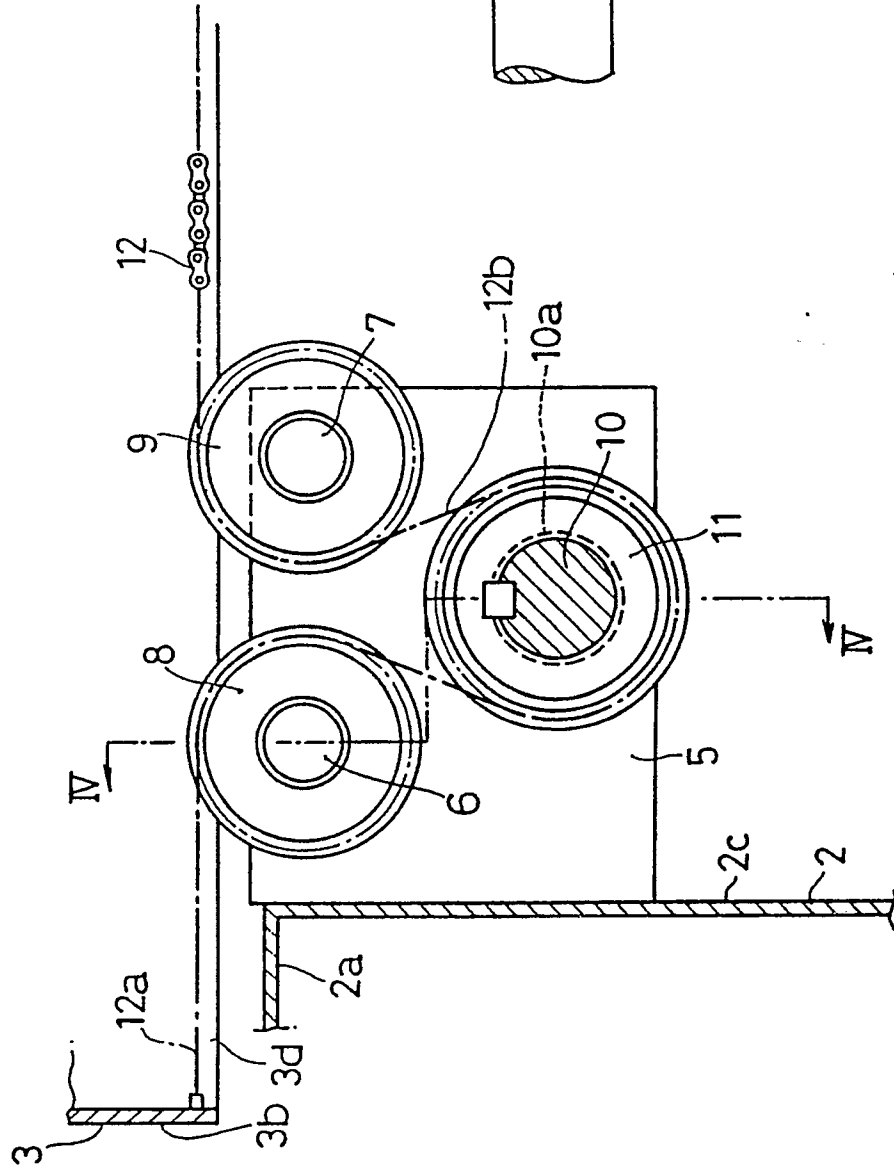

FIG. 4

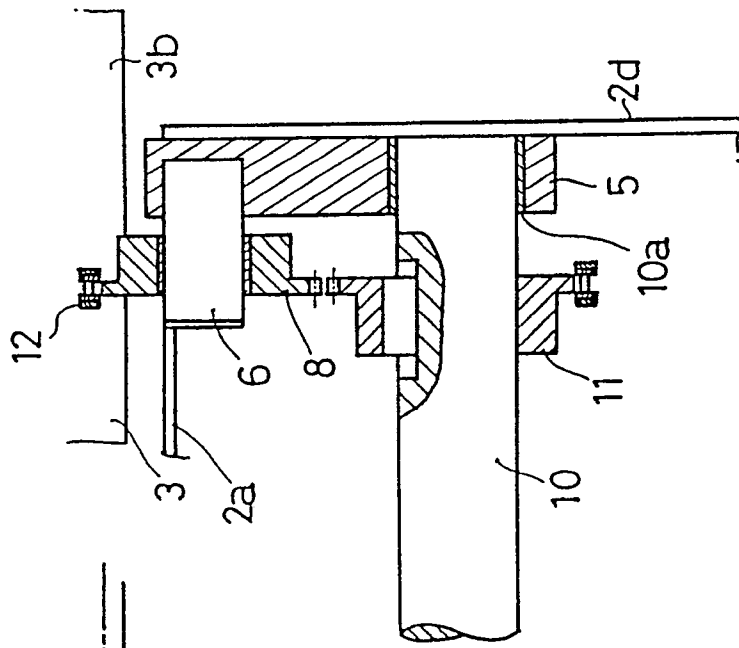

FIG. 5

