



⑫ **EUROPEAN PATENT SPECIFICATION**

④⑤ Date of publication of patent specification :
02.08.95 Bulletin 95/31

⑤① Int. Cl.⁶ : **G09G 3/36**

②① Application number : **89109852.7**

②② Date of filing : **31.05.89**

⑤④ **Liquid crystal apparatus and driving method therefor.**

③⑩ Priority : **01.06.88 JP 135907/88**

④③ Date of publication of application :
06.12.89 Bulletin 89/49

④⑤ Publication of the grant of the patent :
02.08.95 Bulletin 95/31

⑥④ Designated Contracting States :
DE FR GB IT NL

⑤⑥ References cited :
EP-A- 0 244 804

⑦③ Proprietor : **CANON KABUSHIKI KAISHA**
30-2, 3-chome, Shimomaruko,
Ohta-ku
Tokyo (JP)

⑦② Inventor : **Okada, Shinjiro**
1642-2 Ohkami
Hiratsuka-shi Kanagawa-ken (JP)
Inventor : **Inaba, Yutaka**
3-17-1-304 Ryoke
Kawaguchi-shi Saitama-ken (JP)

⑦④ Representative : **Tiedtke, Harro, Dipl.-Ing. et al**
Patentanwaltsbüro
Tiedtke-Bühling-Kinne & Partner
Bavariaring 4
D-80336 München (DE)

EP 0 344 753 B1

Note : Within nine months from the publication of the mention of the grant of the European patent, any person may give notice to the European Patent Office of opposition to the European patent granted. Notice of opposition shall be filed in a written reasoned statement. It shall not be deemed to have been filed until the opposition fee has been paid (Art. 99(1) European patent convention).

DescriptionFIELD OF THE INVENTION AND RELATED ART

5 The present invention relates to a liquid crystal apparatus, more particularly a liquid crystal apparatus using a ferroelectric liquid crystal (hereinafter sometimes abbreviated as "FLC").

Clark and Lagerwall have disclosed a bistable ferroelectric liquid crystal device using a surface-stabilized ferroelectric liquid crystal in Applied Physic Letters, Vol. 36, No. 11 (June 1, 1980), pp. 899 - 901, and U.S. Patents Nos. 4,367,924 and 4,563,059. Such a bistable ferroelectric liquid crystal device has been realized
10 by placing a ferroelectric chiral smectic liquid crystal between a pair of substrates disposed with a gap there-between sufficiently small to suppress the formation of a helical alignment structure of liquid crystal molecules which is inherent in the bulky chiral smectic phase of the liquid crystal and by aligning vertical smectic molecular layers each composed of a plurality of liquid crystal molecules in one direction.

In such a ferroelectric liquid crystal device, there are restrictively formed two stable average longer-molecular axis directions (\hat{n}) with a molecular dipole moment (\hat{p}) parallel to the vertical molecular layer so as to form a spontaneous polarization (P_s) on the average. The spontaneous polarization causes a strong coupling with an applied electric field. When such a ferroelectric liquid crystal is placed in an electric field in one direction, the dipole moments (\hat{p}) in a vertical molecular layer are oriented in the electric field direction. At this time, a maximum tilt angle is attained corresponding to one half of the apex angle of a helical cone in the helical alignment structure. (The molecular alignment state at this time may be referred to as "uniform alignment state U_1 "). When the above-mentioned electric field is removed, the molecules are realigned into another stable alignment state (referred to as "splay alignment state S_1 ") which has a lower degree of order, a lower degree of optically uniaxial characteristic and a lower tilt angle than the uniform alignment state U_1 after some relaxation period (which is generally on the order of 1 - 2 μ sec while dependent on the kind of a ferroelectric liquid crystal used). In the splay alignment state S_1 , the dipole moments of the molecules are not in a single direction but the direction of the spontaneous polarization is the same as in the uniform alignment state U_1 . Further, by application of an electric field in the reverse direction, there are similarly formed a uniform alignment state U_2 and a splay alignment state S_2 .

Accordingly, in case where the above-mentioned ferroelectric liquid crystal device is used as a display panel, the brightness or contrast of the panel is basically governed by the transmittances in the splay alignment states S_1 and S_2 . More specifically, a transmitted light intensity I through a liquid crystal is given by the following equation with respect to the incident light intensity I_0 under cross nicols when the uniaxial alignment of the molecules is assumed:

$$I = I_0 \sin^2(4\theta a) \cdot \sin^2(\pi \Delta n d / \lambda),$$

35 wherein θa denotes a tilt angle; Δn , the refractive index anisotropy of the FLC; d , the cell thickness, and λ , the wavelength of the incident light. According to our experiments, the tilt angle θa in the splay alignment states S_1 and S_2 is generally about 5 - 8 degrees which is too small for providing a sufficient contrast.

With respect to such a problem, a liquid crystal apparatus having a high-frequency AC application means (for utilizing an AC stabilization effect of providing an increased tilt angle) has been disclosed, e.g., by Japanese Laid-Open Patent Applications (KOKAI) Nos. 246722/1986, 246723/1986, 246724/1986, 249024/1986 and 249025/1986. Such an apparatus uses a means for applying a high frequency AC in addition to means for applying switching pulses for driving, so that there arises a problem of a large power consumption.

The AC stabilization effect is governed by the correlation between a torque acting on a molecule due to the spontaneous polarization P_s and a torque acting on the molecule due to the dielectric anisotropy $\Delta\epsilon$. In case of multiplex matrix drive of a ferroelectric liquid crystal device, a broad margin or latitude for a voltage range or frequency range affording a practical drive is desired. However, such a driving margin becomes remarkably narrower in a multiplex drive under such an AC-stabilized condition than in a driving system not utilizing the AC stabilization effect.

50 SUMMARY OF THE INVENTION

An object of the present invention is to provide a liquid crystal apparatus and a method for driving the same capable of applying an AC voltage for providing an increased tilt angle to ferroelectric liquid crystal pixels without superposing such an AC voltage or causing a decrease in driving voltage margin.

55 According to the present invention, this object is achieved by a liquid crystal apparatus, comprising: a liquid crystal device comprising a matrix electrode structure including scanning electrodes and data electrodes intersecting each other and forming a pixel at each intersection, and a ferroelectric liquid crystal having a negative dielectric anisotropy disposed between the scanning electrodes and the data electrodes, said liquid crys-

tal apparatus being characterized by means for applying between a selected scanning electrode and a selected data electrode a bipolar pulse for causing a conversion of one optical state to the other optical state of the selected pixel, the bipolar pulse including a unit pulse of one polarity which has a duration set to be shorter than a minimum value τ_{\min} of a current response time τ_0 , said current response time τ_0 being equal to the time period between an instant at which an applied pulse rises and an instant at which the polarization current in said liquid crystal display reaches a peak in response to said pulse.

Furthermore, this object is achieved by a driving method for a liquid crystal device comprising a matrix electrode structure including scanning electrodes and data electrodes intersecting each other and forming a pixel at each intersection, and a ferroelectric liquid crystal having a negative dielectric anisotropy disposed between the scanning electrodes and the data electrodes; said driving method being characterized by the step of applying between a selected scanning electrode and a selected data electrode a bipolar pulse for causing a conversion of one optical state to the other optical state of the selected pixel, the bipolar pulse including a unit pulse of one polarity which has a duration set to be shorter than a minimum value τ_{\min} of a current response time τ_0 , said current response time τ_0 being equal to the time period between an instant at which an applied pulse rises and an instant at which the polarization current in said liquid crystal display reaches a peak in response to said pulse.

These and other objects, features and advantages of the present invention will become more apparent upon a consideration of the following description of the preferred embodiments of the present invention taken in conjunction with the accompanying drawings.

BRIEF DESCRIPTION OF THE DRAWINGS

Figure 1 is a graph showing changes in tilt angle θ_a versus effective voltage V_{rms} with respect to several ferroelectric liquid crystals having different values of dielectric anisotropy $\Delta\epsilon$;
 Figures 2, 3 and 4 are driving waveform diagrams used in embodiments of the present invention;
 Figure 5 illustrates a correlation between an oscillogram Ch 1 representing an input pulse waveform and an oscillogram Ch 2 representing a current response including a polarization inversion current;
 Figure 6 is a characteristic diagram illustrating a correlation between an applied voltage pulse height and a current response time τ_0 (time from the rising of the voltage pulse until the peak of a polarization inversion current caused by the voltage pulse application) including a minimum value τ_{\min} given under application of varying pulse heights of the applied pulse voltage;
 Figure 7 is a circuit diagram for a polarization inversion current meter;
 Figure 8 is an illustration of an angle θ formed by a C-director;
 Figure 9 is a characteristic diagram showing a relationship between a torque and an applied voltage with the angles of C-director as parameters;
 Figure 10 is a block diagram of an apparatus of the present invention; and
 Figure 11A and 11B are graphs showing threshold characteristics of ferroelectric liquid crystal cells used in the present invention.

DETAILED DESCRIPTION OF THE INVENTION

A torque Γ_{Ps} acting on FLC molecules due to coupling of an applied electric field (E) and the dipole moment and a torque $\Gamma_{\Delta\epsilon}$ acting on FLC molecules due to coupling of the applied electric field (E) and a dielectric anisotropy ($\Delta\epsilon$) are respectively represented by the following formulas:

$$\Gamma_{Ps} \propto Ps \cdot E \quad (1)$$

$$\Gamma_{\Delta\epsilon} \propto 1/2 \cdot \Delta\epsilon \cdot \epsilon_0 \cdot E^2 \quad (2)$$

From the above formula (2), it is understood that a larger dielectric anisotropy $\Delta\epsilon$ promotes the suppression or removal of the helical alignment structure. Further, in case of $\Delta\epsilon < 0$, liquid crystal molecules are forced under an applied electric field to align so as to provide a predominant proportion of projection component on the substrate, whereby the helical alignment structure is suppressed.

Figure 1 attached hereto shows the change of tilt angles θ_a versus V_{rms} experimentally measured for 4 FLCs having different values of $\Delta\epsilon$. The measurement was conducted under application of AC rectangular pulses of 60 KHz so as to remove the influence of Ps. The curves (I) - (IV) correspond to the results obtained by using FLCs showing the following $\Delta\epsilon$ values

- (I) $\Delta\epsilon \approx -5.5$, (II) $\Delta\epsilon \approx -3.0$,
- (III) $\Delta\epsilon \approx -0$, (IV) $\Delta\epsilon \approx 1.0$.

As is clear from the graph in Figure 1, a large negative value of $\Delta\epsilon$ provides a larger θ_a at a lower voltage and thus contributes to provision of an increased I.

The maximum transmittances obtained by using the liquid crystals (I) and (III) were 15 % for (I) and 6 % for (III) (under cross nicols and application of rectangular AC waveforms of 60 KHz and ± 8 V), thus showing a clear difference.

Figures 2 - 4 respectively illustrate a driving waveform embodiment. In the figures, at S_1 , S_2 and S_3 are shown scanning signals, and at I are shown data signals. Further, at A ($S_1 - I$) is shown a combined voltage waveform applied to a pixel at the intersection of a scanning line S_1 and a data line I in a selection period and a non-selection period.

The ferroelectric liquid crystal used in the present invention may preferably be a chiral smectic liquid crystal having a negative dielectric anisotropy $\Delta\epsilon$. There is known, for example, "CS-1011" (trade name, available from Chisso K.K.) as a commercially available material. The ferroelectric liquid crystal may preferably have a dielectric anisotropy $\Delta\epsilon$ of -1.0 or below. The ferroelectric liquid crystal may preferably be disposed in a layer thin enough to suppress the formation of a helical molecular alignment structure inherent to bulk chiral smectic phase in the absence of an electric field, e.g., in a thickness of 0.5 to 10 microns, more preferably 1.0 - 5.0 microns. The ferroelectric liquid crystal layer may preferably be disposed in contact with an alignment control film comprising, e.g., a polyimide film, polyamide film, polyamide-imide film, polyester-imide film or polyvinyl alcohol film subjected to a rubbing treatment, or an SiO or SiO₂ film formed by oblique vapor deposition, so that a monodomain may be effectively formed.

The ferroelectric liquid crystal used in the present invention may cause a polarization inversion current when supplied with a voltage pulse as shown in Figure 5. A time from an instant of a pulse rise to an instant giving a peak P of the polarization inversion current may be referred to as a current response time τ_0 . The current response time τ_0 depends on the applied voltage (pulse waveheight). Figure 6 shows the dependence of the current response time τ_0 on the applied voltage V with respect to two types of liquid crystals, i.e., liquid crystal A and liquid crystal B which will be described hereinafter. As shown in Figure 6, the liquid crystal A provided a minimum value $\tau_{min} = 110$ μ sec of the current response time τ_0 in the neighborhood of an applied voltage of 20 volts (providing an electric field intensity E_1 for a cell gap of 1.5 micron), while the liquid crystal B provided no minimum value τ_{min} .

The above-mentioned current response time τ_0 may be measured by means of a current response time meter as shown in Figure 7. The meter includes a pulse generator 71 for generating a pulse of 5 Hz, a resistor 72 of 1 K Ω , a ferroelectric liquid crystal cell 73, an oscillograph Ch 1 providing an oscillogram as shown at Ch 1 in Figure 5 and also an oscillograph Ch 2 providing an oscillogram as shown at Ch 2 in Figure 5.

In a preferred embodiment, when an electric field intensity providing the above-mentioned minimum value τ_{min} is defined as E_1 (about 20 volts/1.5 micron for the liquid crystal A described hereinafter) and a maximum pulse duration ΔT in a data signal pulse train is set to below the minimum value τ_{min} , a voltage providing an electric field intensity E exceeding the electric field intensity E_1 may be applied to a half-selected point on a writing line to prevent the occurrence of crosstalk. This is presumably because, at such a half-selected point, a high-frequency AC is applied to cause a $\Delta\epsilon$ -coupling due to a dielectric anisotropy, so that the application of the voltage providing an electric field intensity exceeding E_1 suppresses the inversion of molecular orientation or the molecular fluctuation of the liquid crystal. Accordingly, in a preferred embodiment of the present invention, the electric field intensity applied at a half-selected point may be set to satisfy the following formula (3):

$$E_0 > E_1 \quad (3),$$

wherein E_1 denotes an electric field intensity (V/m or V/ μ m) corresponding to the minimum value τ_{min} ; E_0 (= V/d) denotes an electric field intensity at a half-selected point; V (volts) denotes a voltage applied at the half-selected point; and d (m or μ m) denotes a spacing between a pair of opposite electrodes.

Further, the present invention may be applicable to a static drive using a common signal and a data signal pulse train in addition to the above-mentioned multiplexing drive using a scanning selection signal and a data pulse train.

Figure 8 illustrates an angle θ of a C-director 81 with respect to an axis 84 in parallel with a substrate (hereinafter referred to as "C-director angle θ "). The C-director represents a projection of a liquid crystal molecule long axis on a vertical molecular layer comprising a plurality of chiral smectic liquid crystal molecules. Further, a direction increasing the C-director angle θ is represented by a positive torque 82, and a direction decreasing the C-director angle θ is represented by a negative torque 83.

Figure 9 shows a relationship between the applied voltage (for a thickness of 1.5 micron) and the torque with C-director angles θ as parameters.

Figure 8 shows that a larger positive torque 82 is liable to cause an inversion switching, and a large negative torque is liable to suppress the inversion switching. Figure 9 shows that a smaller C-director angle θ of 50 degrees or less provides a larger negative torque 83 so that the dielectric anisotropy coupling becomes predominant to suppress the inversion switching. On the other hand, in case where the C-director angle θ is 60 degrees,

an applied voltage of about 10 volts provides a maximum positive torque, so that an inversion switching is caused even at a relatively low applied voltage of about 10 volts, for a cell gap of 1.5 micron. Further, in case where the C-director angle is increased up to 80 degrees, the readiness of the inversion is further increased.

Accordingly, in the present invention, an increase in driving voltage margin may be attained by applying first a low-waveheight pulse and then a high-waveheight pulse for causing an inversion switching to a ferroelectric liquid crystal placed in such an alignment state as to be formed under application of an alternating voltage causing a dielectric anisotropy coupling (i.e., an alignment state set to provide a small C-director angle). Further, in a preferred embodiment of the present invention, a half-selected point at the intersection of a selected scanning electrode and a non-selected data electrode may be supplied with first a high-waveheight pulse and then with a low-waveheight pulse to effectively prevent the inversion switching.

In order to cause an alignment state providing a small C-director angle θ , there may be applied a method of applying an AC voltage of a high frequency, e.g., above a relaxation frequency, to non-selected pixels under driving (Japanese Laid-Open Patent Applications Nos. 246722/1986, 246723/1986, 246724/1986, 249024/1986 and 249025/1986, U.S. Patent No. 4668051, etc.), or a method of applying a high frequency AC prior to driving (Japanese Laid-Open Patent Applications Nos. 220930/1987 and 223729/1987).

Figure 10 illustrates a driving apparatus for a ferroelectric liquid crystal panel 101 comprising a matrix electrode arrangement used in the present invention. Referring to Figure 10, the panel comprises scanning lines 102 and data lines 103 intersecting each other, and a ferroelectric liquid crystal (not shown) is interposed between the scanning line and the data lines so as to form a pixel at each intersection. The driving apparatus further includes a scanning circuit 104, a scanning side drive circuit 105, a data side drive voltage generating circuit 106, a line memory 107, a shift register 108, a scanning side drive voltage generating power supply 109, and a microprocessor unit (MPU) 100. The scanning side drive voltage generating power supply 109 is provided with voltages V_1 , V_2 and V_C , of which the voltages V_1 and V_2 may be used as sources of the above-mentioned scanning selection signal and the voltage V_C may be used as a source of a scanning non-selection signal.

Next, the present invention will be explained based on examples.

Example

A glass substrate having thereon ITO (indium-tin-oxide) film stripes as transparent electrodes was coated with a 1000 Å-thick SiO₂ film by sputtering and further with a 500 Å-thick polyimide film by using a polyamic acid solution ("SP-710" (trade name) available from Toray K.K.). The polyimide film was treated by rubbing with acetate fiber-planted cloth.

Two of the thus rubbing-treated glass substrates were provided. On one of the glass substrates, silica beads having an average particle size of 1.5 micron was disposed to provide a cell gap of about 1.5 micron, and the other glass substrate was superposed and bonded thereto so that their stripe electrodes intersected each other and their rubbing axes were in parallel with each other.

Two blank cell were prepared in the above described manner and were filled with chiral smectic liquid crystals A and B, respectively, having the following characteristics:

Liquid Crystal A (at 25 °C)

Spontaneous polarization P_s : 12.9 nC/cm²

τ_{min} : 110 μsec (at 20 V)

$\Delta\epsilon$: -5.8

Apex angle \textcircled{H} in a helical structure:

23 degrees

Threshold pulse duration by 18 V rectangular pulse:

120 μsec

Phase transition series:

EP 0 344 753 B1

Iso. → Ch → SmA → SmC

wherein Iso denotes isotropic phase; Ch, cholesteric phase; SmA, smectic A phase; and SmC, chiral smectic C phase.

5

Liquid Crystal B (at 25 °C)

10

Spontaneous polarization Ps: 6.6 nC/cm²

τ_{min} : none

$\Delta\epsilon$: -0.1

15

Apex angle \textcircled{H} in a helical structure:

23 degrees

Threshold pulse duration by 18 V rectangular pulse:

20

50 μ sec

Phase transition series:

25

Iso. → Ch → SmA → SmC

30

The threshold characteristics of the liquid crystals A and B are shown in Figures 11A and 11B wherein Δ and \circ denote the threshold voltage values, and \blacktriangle and \bullet denote the saturation voltage values. Figure 11A shows the characteristics obtained under application of a bipolar pulse of V and -V, while Figure 11B shows the characteristics obtained under application of a unipolar pulse of V.

Then, the above-prepared two devices were driven by applying a set of driving waveforms shown in Figure 3 under the following set of conditions A, whereby the device containing the liquid crystal A provided a display image of a high contrast but the device containing the liquid crystal B provided a dark display image of a low contrast.

35

Condition A

40

$\Delta T_1 = 30 \mu\text{sec}$, $\Delta T_2 = 60 \mu\text{sec}$,

$\Delta T_3 = 30 \mu\text{sec}$,

$|\pm 17 \text{ V}| < |\pm(V_1+V_3)| < |\pm 31 \text{ V}|$

$V_1 = V_2$

Bias ratio ($= |\pm V_3| / |(V_1+V_2)|$) = 1/3 (constant).

45

Further, the devices were driven by applying a set of driving waveforms shown in Figure 2 under the following set of conditions B, whereby the device containing the liquid crystal A provided a display image of a high contrast but the device containing the liquid crystal B provided a dark display image of a low contrast.

Condition B

50

$V_1 = 14 \text{ V}$, $V_2 = 10 \text{ V}$,

$V_3 = 14 \text{ V}$, $V_4 = 10 \text{ V}$,

$36 \mu\text{sec} \leq \Delta T \leq 54 \mu\text{sec}$.

55

Further, the two devices were driven by applying a set of driving waveforms shown in Figure 4 under the following sets of conditions C and D, respectively, whereby the device containing the liquid crystal A provided display images of a high contrast but the device containing the liquid crystal B provided dark display images of a low contrast.

Condition C

$$\begin{aligned}
 V_1 &= 16 \text{ V}, & V_2 &= 16 \text{ V}, \\
 V_3 &= 8 \text{ V}, \\
 52 \text{ } \mu\text{sec} &\leq \Delta T_2 \leq 92 \text{ } \mu\text{sec}.
 \end{aligned}$$

Condition D

$$\begin{aligned}
 V_1 &= 16 \text{ V}, & V_2 &= 16 \text{ V}, \\
 V_3 &= 8 \text{ V} \\
 112 \text{ } \mu\text{sec} &\leq \Delta T_2 \leq 132 \text{ } \mu\text{sec}.
 \end{aligned}$$

With respect to the device containing the liquid crystal A, the conversion of an optical state was caused by application of a former pulse A and not caused by application of a latter pulse B under the conditions C. On the other hand, during the driving under the conditions D, the conversion of an optical state was caused not by application of a former pulse A but by application of a latter pulse B.

According to the present invention, it is further possible to control a DC bias component to an arbitrary level, preferably to zero. Further, according to the present invention, a display of a high contrast can be realized free of crosstalk.

Claims

1. A liquid crystal apparatus, comprising:
 - a liquid crystal device (101) comprising a matrix electrode structure including scanning electrodes (102) and data electrodes (103) intersecting each other and forming a pixel at each intersection, and a ferroelectric liquid crystal having a negative dielectric anisotropy disposed between said scanning electrodes (102) and said data electrodes (103), said liquid crystal apparatus being **characterized by** means for applying between a selected scanning electrode (102) and a selected data electrode (103) a bipolar pulse for causing a conversion of one optical state to the other optical state of the selected pixel, said bipolar pulse including a unit pulse (Pulse A) of one polarity which has a duration (ΔT) set to be shorter than a minimum value τ_{\min} of a current response time τ_0 , said current response time τ_0 being equal to the time period between an instant at which an applied pulse rises and an instant at which the polarization current in said liquid crystal display reaches a peak in response to said pulse.
2. An apparatus according to claim 1, **characterized in that** said means applies between non-selected scanning and data electrodes (102, 103) an AC voltage not changing the optical state of the non-selected pixels.
3. An apparatus according to claim 1 or 2, **characterized in that** said unit pulse (Pulse A) having a duration (ΔT) shorter than said minimum value τ_{\min} has a waveheight providing an electric field intensity higher than an electric field intensity (E_1) giving the minimum value τ_{\min} of said current response time τ_0 .
4. An apparatus according to claim 1 or 2, **characterized in that** said unit pulse (Pulse A) having a duration (ΔT) shorter than said minimum value τ_{\min} is disposed in a former half of said bipolar pulse.
5. An apparatus according to claim 1 or 2, **characterized in that** said unit pulse (Pulse B) having a duration (ΔT) shorter than said minimum value τ_{\min} is disposed in a latter half of said bipolar pulse.
6. An apparatus according to any of the preceding claims 1 to 5, **characterized in that** said ferroelectric liquid crystal is a chiral smectic liquid crystal.
7. A driving method for a liquid crystal device (101) comprising a matrix electrode structure including scanning electrodes (102) and data electrodes (103) intersecting each other and forming a pixel at each intersection, and a ferroelectric liquid crystal having a negative dielectric anisotropy disposed between said scanning electrodes (102) and said data electrodes (103); said driving method being **characterized by** the step of
 - applying between a selected scanning electrode (102) and a selected data electrode (103) a bipolar pulse for causing a conversion of one optical state to the other optical state of the selected pixel, said

bipolar pulse including a unit pulse (pulse A) of one polarity which has a duration (ΔT) set to be shorter than a minimum value τ_{\min} of a current response time τ_0 , said current response time τ_0 being equal to the time period between an instant at which an applied pulse rises and an instant at which the polarization current in said liquid crystal display reaches a peak in response to said pulse.

5

8. A driving method according to claim 7, **characterized by** the further step of applying between non-selected scanning and data electrodes (102, 103) an AC voltage not changing the optical state of the non-selected pixels.
- 10 9. A driving method according to claims 7 or 8, **characterized in that** said unit pulse (Pulse A) having a duration (ΔT) shorter than said minimum value τ_{\min} has a waveheight providing an electric field intensity higher than an electric field intensity (E_1) giving the minimum value τ_{\min} of said current response time τ_0 .
- 15 10. A driving method according to claims 7 or 8, **characterized in that** said unit pulse (Pulse A) having a duration (ΔT) shorter than said minimum value τ_{\min} is disposed in a former half of said bipolar pulse.
11. A driving method according to claims 7 to 8, **characterized in that** said unit pulse (Pulse B) having a duration (ΔT) shorter than said minimum value τ_{\min} is disposed in a latter half of said bipolar pulse.
- 20 12. A driving method according to any of the preceding claims 7 to 11, **characterized in that** said ferroelectric liquid crystal is a chiral smectic liquid crystal.

Patentansprüche

25

1. Flüssigkristallgerät mit einer Flüssigkristallvorrichtung (101) mit einer matrixförmigen Elektrodenstruktur, die sich gegenseitig überkreuzende Abtastelektroden (102) und Datenelektroden (103) aufweisen, und an jeder Überkreuzung einen Bildpunkt ausbilden, und einem ferroelektrischen Flüssigkristall mit einer negativen dielektrischen Anisotropie, das zwischen den Abtastelektroden (102) und den Datenelektroden (103) liegt, **gekennzeichnet durch** eine Vorrichtung zum Anlegen eines bipolaren Impulses zwischen eine ausgewählte Abtastelektrode (102) und eine ausgewählte Datenelektrode (103), wodurch eine Umwandlung des ausgewählten Bildpunktes von einem optischen Zustand in einen anderen optischen Zustand verursacht wird, wobei der bipolare Impuls einen Einheitsimpuls (Impuls A) besitzt, der eine Polarität aufweist, und dessen Zeitdauer (ΔT) auf einen Wert gesetzt wird, der kürzer als ein minimaler Wert τ_{\min} einer Strom-Ansprechzeit τ_0 ist, und wobei die Strom-Ansprechzeit τ_0 einer Zeitdauer entspricht, die von einem Zeitpunkt, an dem der angelegte Impuls ansteigt, und einem Zeitpunkt, an dem der Polarisationsstrom in der Flüssigkristallanzeige im Ansprechen auf den Impuls einen Scheitelwert erreicht, festgelegt ist.
- 40 2. Ein Gerät nach Anspruch 1, **dadurch gekennzeichnet, daß** die Vorrichtung zwischen nicht ausgewählten Abtast- und Datenelektroden (102, 103) eine Wechselspannung angelegt wird, die den optischen Zustand des nicht ausgewählten Bildpunktes nicht ändert.
- 45 3. Gerät nach Anspruch 1 oder 2, **dadurch gekennzeichnet, daß** der Einheitsimpuls (Impuls A) mit einer gegenüber dem minimalen Wert τ_{\min} kürzeren Zeitdauer (ΔT) eine Signalamplitude aufweist, die eine höhere elektrische Feldstärke aufweist, als die beim minimalen Wert τ_{\min} der Strom-Ansprechzeit τ_0 gegebene elektrische Feldstärke (E_1).
- 50 4. Gerät nach Anspruch 1 oder 2, **dadurch gekennzeichnet, daß** der Einheitsimpuls (Impuls A) mit einer gegenüber dem minimalen Wert τ_{\min} kürzeren Zeitperiode (ΔT) in einer vorderen Hälfte des bipolaren Impulses angeordnet ist.
- 55 5. Gerät nach Anspruch 1 oder 2, **dadurch gekennzeichnet, daß**

der Einheitsimpuls (Impuls B) mit einer gegenüber dem minimalen Wert τ_{\min} kürzeren Zeitdauer (ΔT) in einer späteren Hälfte des bipolaren Impulses angeordnet ist.

- 5 6. Gerät einem der Ansprüche 1 bis 5,
dadurch gekennzeichnet, daß
das ferroelektrische Flüssigkristall ein chiral-smektisches Flüssigkristall ist.
- 10 7. Verfahren zum Ansteuern eines Flüssigkristallgeräts (101) mit einer Matrixelektrodenstruktur, die sich überkreuzende Abtastelektroden (102) und Datenelektroden (103) aufweist, die an den jeweiligen Überkreuzungen einen Bildpunkt ausbildet, und einem ferroelektrischen Flüssigkristall mit einer negativen dielektrischen Anisotropie, welches zwischen den Abtastelektroden (102) und den Datenelektroden (103) angeordnet ist,
gekennzeichnet durch
den Schritt eines Anlegens eines bipolaren Impulses zwischen eine ausgewählte Abtastelektrode (102) und eine ausgewählte Datenelektrode (103), wodurch in dem ausgewählten Bildpunkt eine Umwandlung von einem optischen Zustand in einen anderen optischen Zustand verursacht wird, wobei der bipolare Impuls einen Einheitsimpuls (Impuls A) aufweist, der eine Polarität besitzt und eine gegenüber einem minimalen Wert τ_{\min} einer Strom-Ansprechzeit τ_0 kürzere Zeitdauer (ΔT) aufweist, und wobei die Strom-Ansprechzeit τ_0 einer Zeitdauer entspricht, die von einem Zeitpunkt, an dem der angelegte Impuls ansteigt und einem Zeitpunkt, an dem der Polarisationsstrom in der Flüssigkristallanzeige im Ansprechen auf den Impuls einen Scheitelwert erreicht, festgelegt ist.
- 20 8. Verfahren nach Anspruch 7,
gekennzeichnet durch
den weiteren Schritt eines Anlegens einer Wechselfspannung zwischen die nicht ausgewählten Abtast- und Datenelektroden (102, 103), wodurch der optische Zustand des nicht ausgewählten Bildpunktes nicht verändert wird.
- 30 9. Verfahren nach Anspruch 7 oder 8,
dadurch gekennzeichnet, daß
der Einheitsimpuls (Impuls A) mit einer gegenüber dem minimalen Wert τ_{\min} kürzeren Zeitdauer (ΔT) eine Signalamplitude aufweist, die eine höhere elektrische Feldstärke erzeugt, als eine beim minimalen Wert τ_{\min} der Strom-Ansprechzeit τ_0 gegebenen elektrischen Feldstärke (E_1).
- 35 10. Verfahren nach Anspruch 7 oder 8,
dadurch gekennzeichnet, daß
der Einheitsimpuls (Impuls A) mit einer gegenüber dem minimalen Wert (τ_{\min}) kleineren Zeitdauer (ΔT) in einer vorderen Hälfte des bipolaren Impulses liegt.
- 40 11. Verfahren nach Anspruch 7 oder 81,
dadurch gekennzeichnet, daß
der Einheitsimpuls (Impuls B) mit einer gegenüber dem minimalen Wert (τ_{\min}) kürzeren Zeitdauer (ΔT) in einer späteren Hälfte des bipolaren Impulses liegt.
- 45 12. Verfahren nach einem der Ansprüche 7 bis 11,
dadurch gekennzeichnet, daß
das ferroelektrische Flüssigkristall ein chiral-smektisches Flüssigkristall ist.

50 Revendications

1. Appareil à cristal liquide comprenant:
un dispositif (101) à cristal liquide comprenant une structure à matrice d'électrodes comportant des électrodes (102) de balayage et des électrodes (103) de données se coupant mutuellement et formant
55 un pixel à chaque intersection, et un cristal liquide ferroélectrique ayant une anisotropie diélectrique négative, disposé entre lesdites électrodes (102) de balayage et lesdites électrodes (103) de données, ledit appareil à cristal liquide étant caractérisé par :
un moyen pour appliquer, entre une électrode (102) de balayage sélectionnée et une électrode

- (103) de données sélectionnée, une impulsion bipolaire pour provoquer la conversion d'un état optique en l'autre état optique du pixel sélectionné, ladite impulsion bipolaire comprenant une impulsion unité (Impulsion A) d'une polarité ayant une durée (ΔT) réglée de façon à être plus courte qu'une valeur minimale (τ_{\min}) d'un temps de réponse de courant τ_0 , ledit temps de réponse de courant τ_0 étant égal au temps entre l'instant du front montant d'une impulsion appliquée et l'instant où le courant de polarisation dans ledit afficheur à cristal liquide atteint un pic en réponse à ladite impulsion.
2. Appareil selon la revendication 1, caractérisé en ce que ledit moyen applique, entre des électrodes de balayage et de données non sélectionnées (102, 103), une tension alternative ne modifiant pas l'état optique des pixels non sélectionnés.
 3. Appareil selon la revendication 1 ou 2, caractérisé en ce que ladite impulsion unité (Impulsion A) ayant une durée (ΔT) inférieure à ladite valeur minimale (τ_{\min}) a une amplitude crête-crête fournissant une intensité de champ électrique supérieure à une intensité de champ électrique (E_1) donnant la valeur minimale τ_{\min} dudit temps de réponse de courant τ_0 .
 4. Appareil selon la revendication 1 ou 2, caractérisé en ce que ladite impulsion unité (Impulsion A) ayant une durée (ΔT) inférieure à ladite valeur minimale (τ_{\min}) est disposée dans une première moitié de ladite impulsion bipolaire.
 5. Appareil selon la revendication 1 ou 2, caractérisé en ce que ladite impulsion unité (Impulsion B) ayant une durée (ΔT) inférieure à ladite valeur minimale τ_{\min} est disposée dans une deuxième moitié de ladite impulsion bipolaire.
 6. Appareil selon l'une quelconque des revendications 1 à 5 précédentes, caractérisé en ce que ledit cristal liquide ferroélectrique est un cristal liquide smectique chiral.
 7. Procédé d'attaque pour un dispositif (101) à cristal liquide comprenant une structure à matrice d'électrodes comportant des électrodes (102) de balayage et des électrodes (103) de données se coupant mutuellement et formant un pixel à chaque intersection, et un cristal liquide ferroélectrique ayant une anisotropie diélectrique négative disposé entre lesdites électrodes (102) de balayage et lesdites électrodes (103) de données; ledit procédé d'attaque étant caractérisé par l'étape consistant à :
appliquer entre une électrode (102) de balayage sélectionnée et une électrode (103) de données sélectionnée, une impulsion bipolaire pour provoquer la conversion d'un état optique en l'autre état optique du pixel sélectionné, ladite impulsion bipolaire comprenant une impulsion unité (Impulsion A) d'une polarité ayant une durée (ΔT) réglée de façon à être plus courte qu'une valeur minimale τ_{\min} d'un temps de réponse de courant τ_0 , ledit temps de réponse de courant τ_0 étant égal au temps entre l'instant du front montant d'une impulsion appliquée et l'instant où le courant de polarisation dans ledit afficheur à cristal liquide atteint un pic en réponse à ladite impulsion.
 8. Procédé d'attaque selon la revendication 7, caractérisé par l'étape supplémentaire consistant à :
appliquer entre des électrodes de balayage et de données non sélectionnées (102, 103), une tension alternative ne modifiant pas l'état optique des pixels non sélectionnés.
 9. Procédé d'attaque selon la revendication 7 ou 8, caractérisé en ce que ladite impulsion unité (Impulsion A) ayant une durée (ΔT) inférieure à ladite valeur minimale τ_{\min} a une amplitude crête-crête fournissant une intensité de champ électrique supérieure à une intensité de champ électrique (E_1) donnant la valeur minimale τ_{\min} dudit temps de réponse de courant τ_0 .
 10. Procédé d'attaque selon la revendication 7 ou 8, caractérisé en ce que ladite impulsion unité (Impulsion A) ayant une durée (ΔT) inférieure à ladite valeur minimale τ_{\min} est disposée dans une première moitié de ladite impulsion bipolaire.
 11. Procédé d'attaque selon la revendication 7 ou 8, caractérisé en ce que ladite impulsion unité (Impulsion B) ayant une durée (ΔT) inférieure à ladite valeur minimale τ_{\min} est disposée dans une deuxième moitié de ladite impulsion bipolaire.
 12. Procédé d'attaque selon l'une quelconque des revendications 7 à 11 précédentes, caractérisé en ce que ledit cristal liquide ferroélectrique est un cristal liquide smectique chiral.

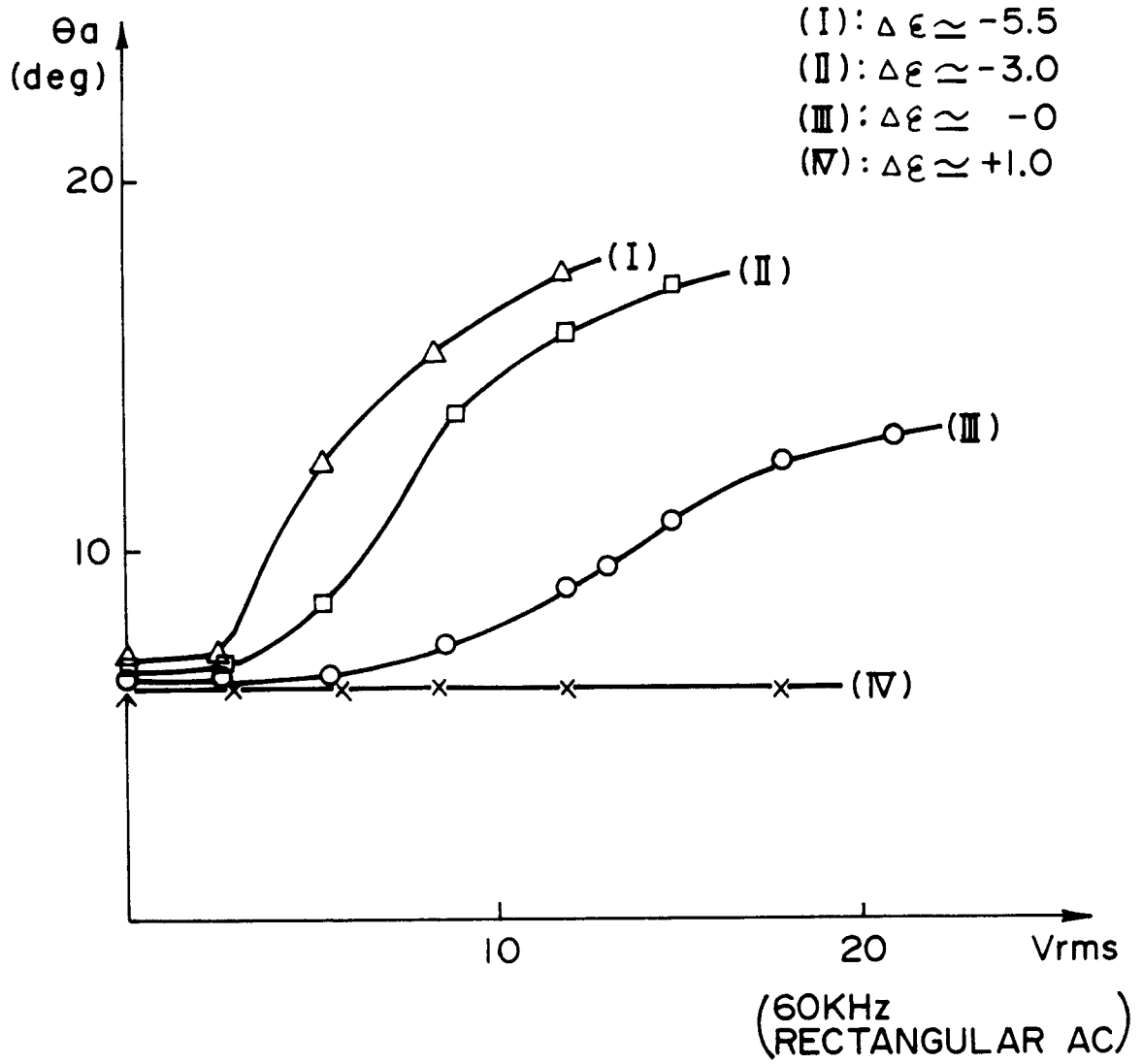

FIG. 1

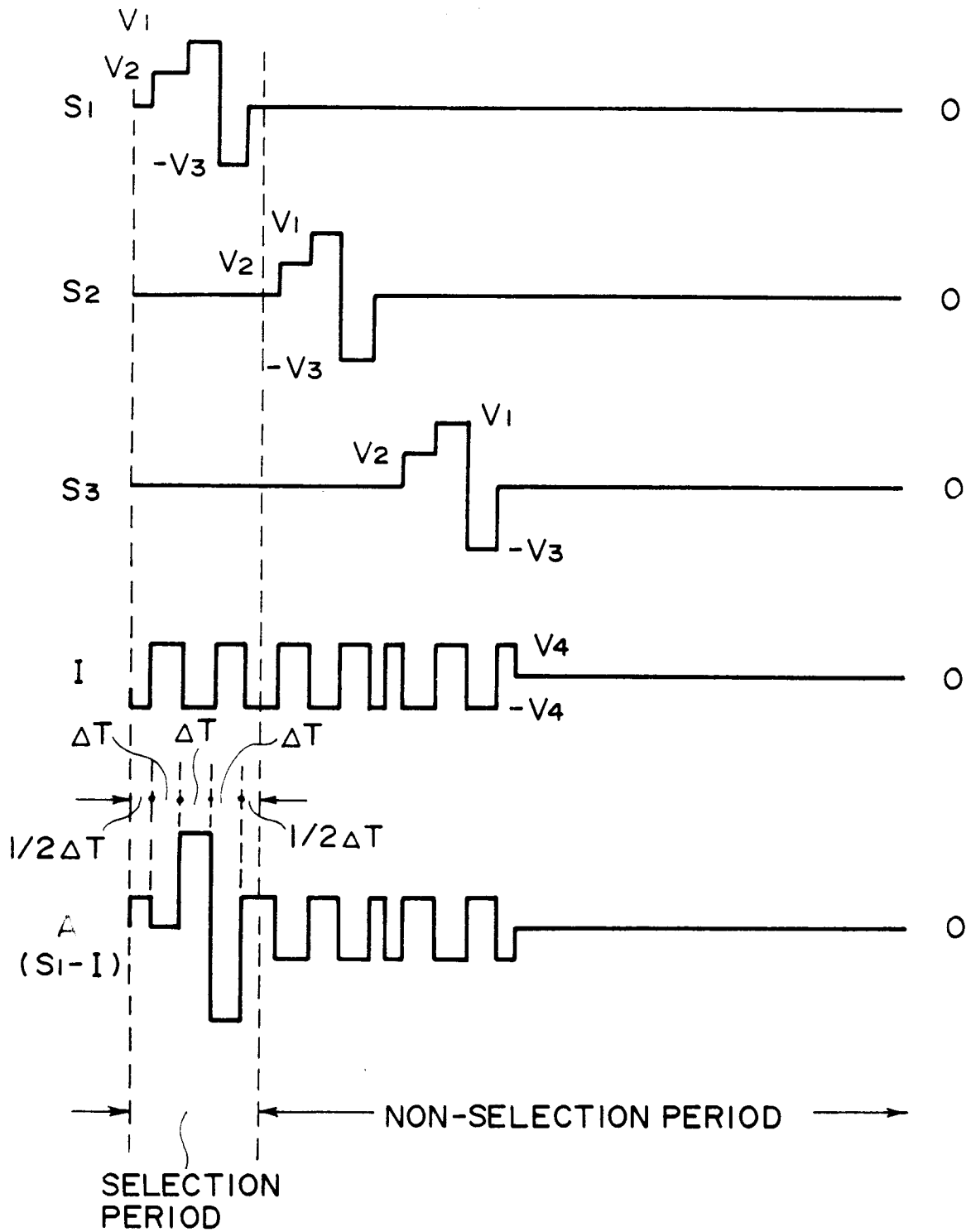

FIG. 2

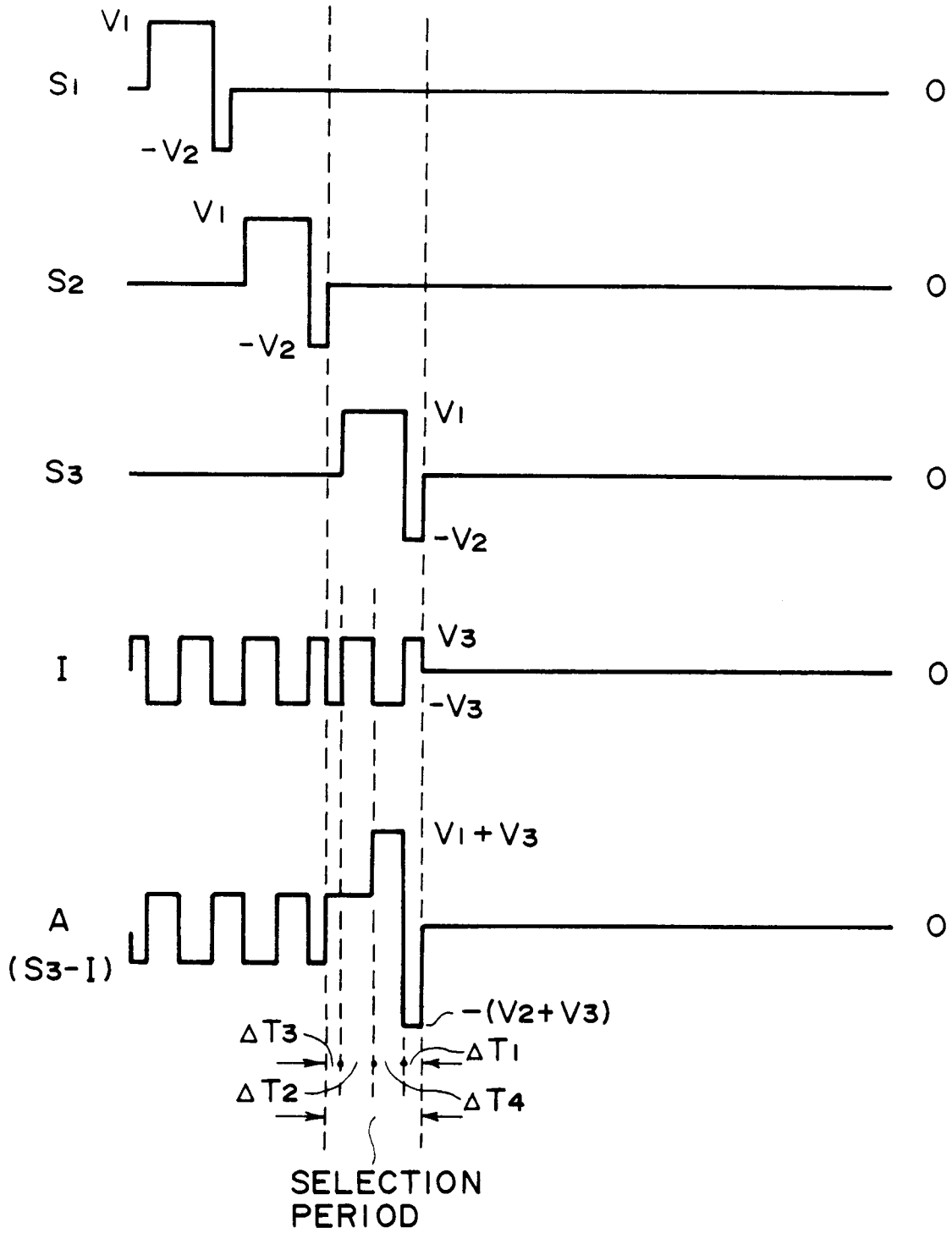

FIG. 3

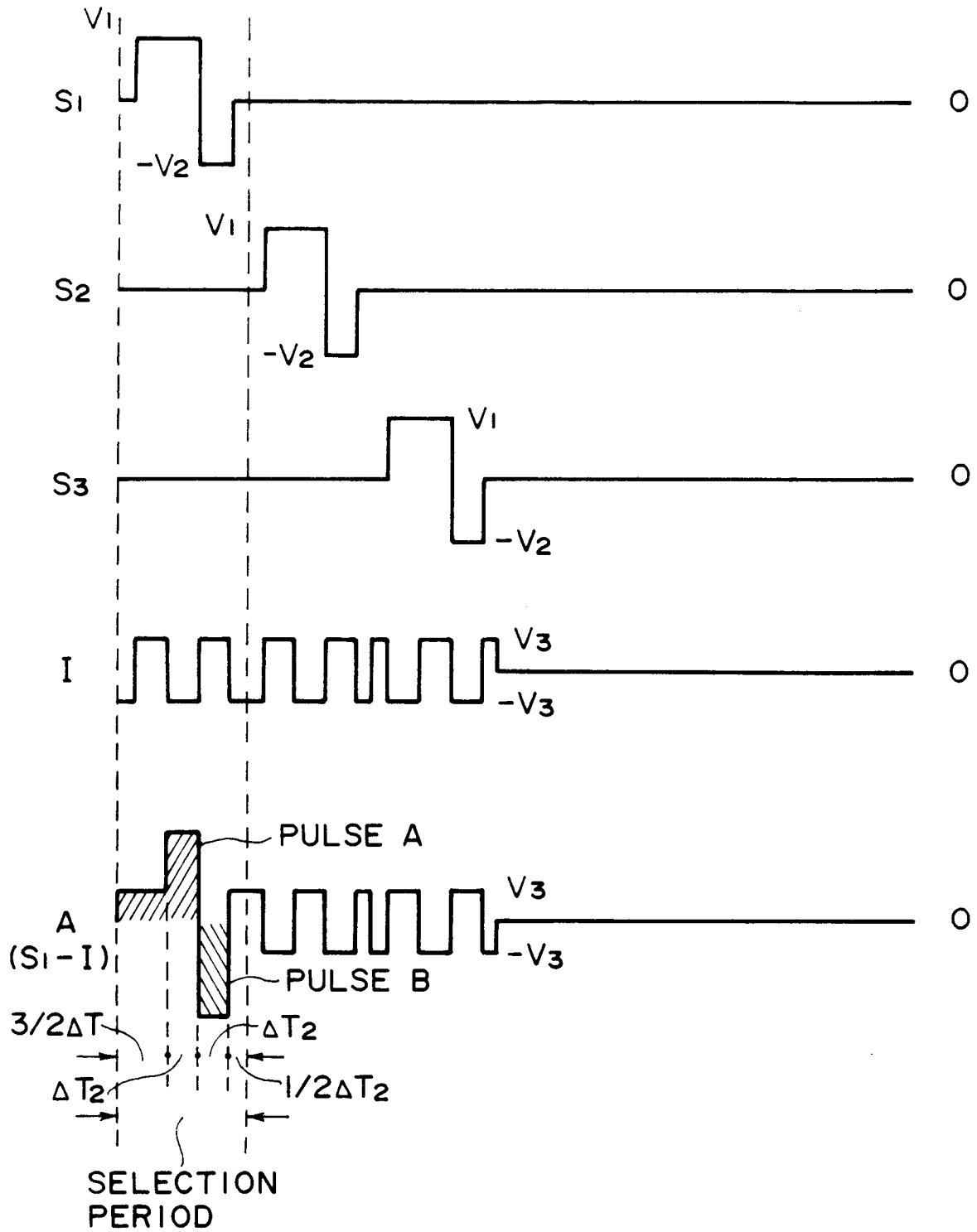

FIG. 4

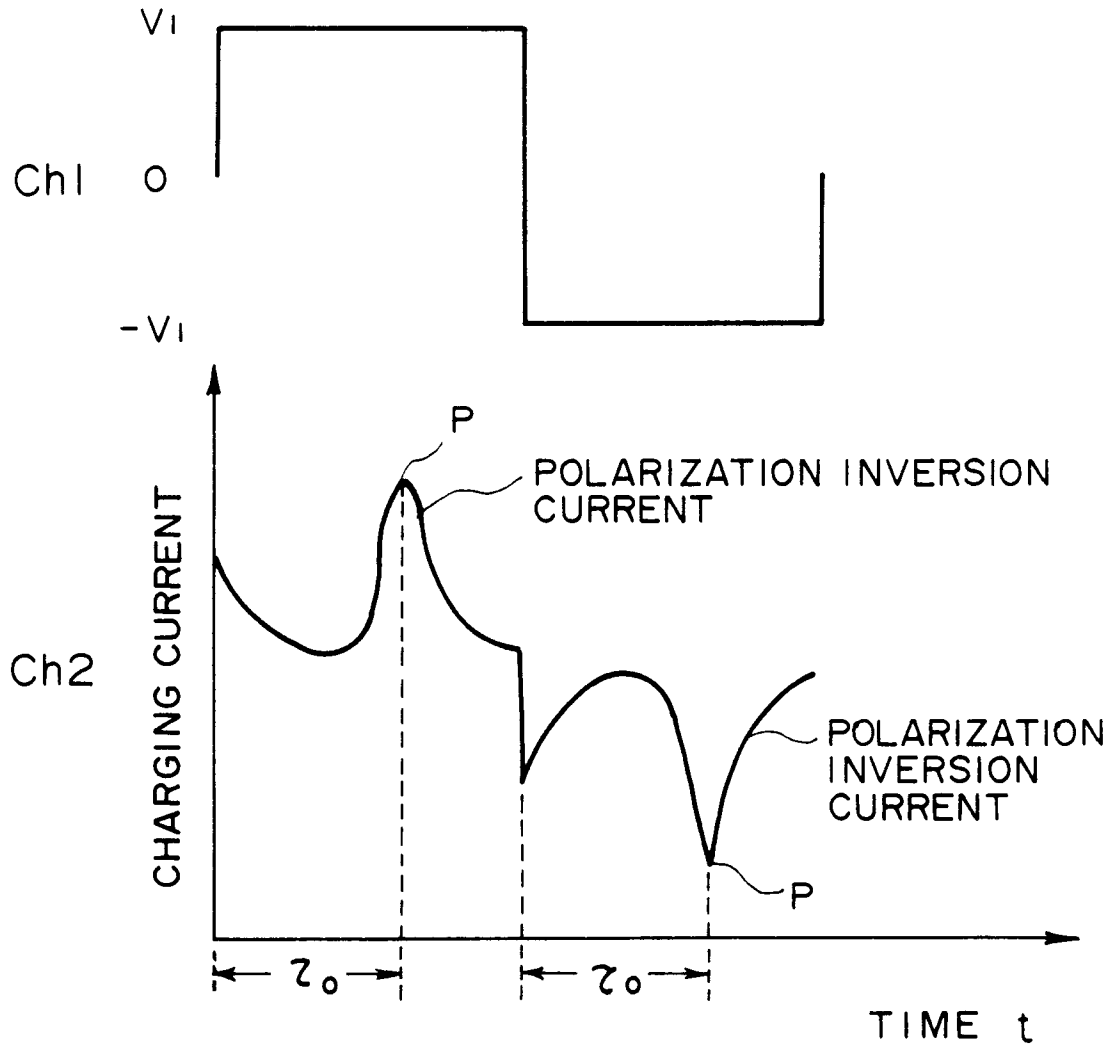

FIG. 5

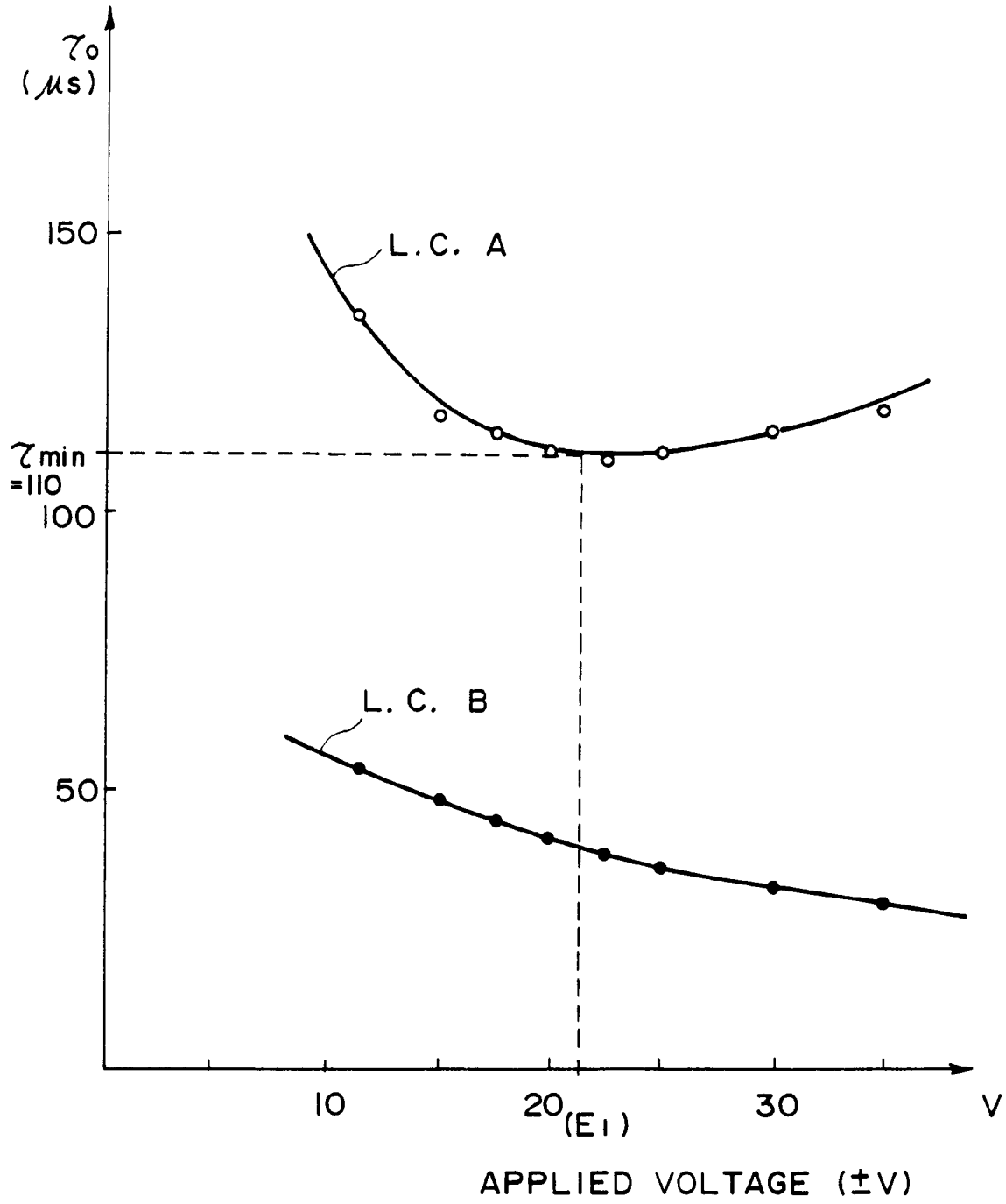

FIG. 6

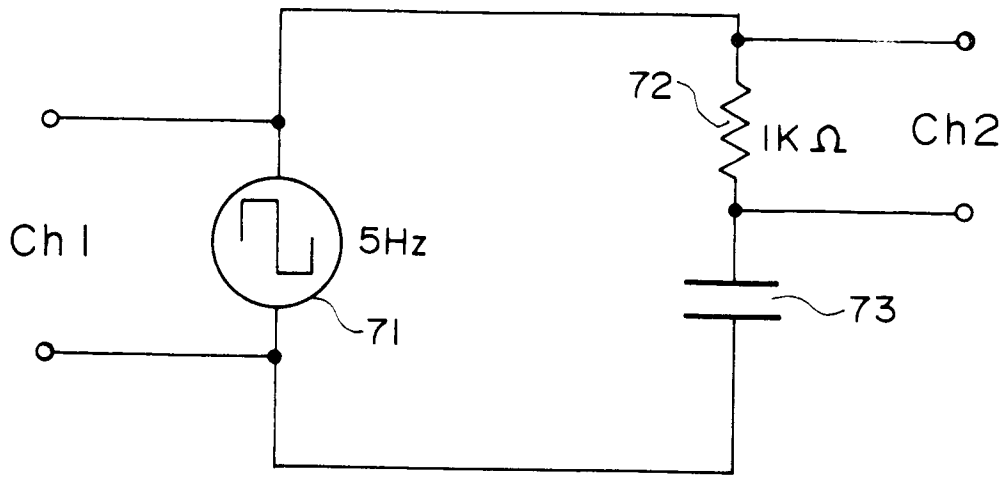

FIG. 7

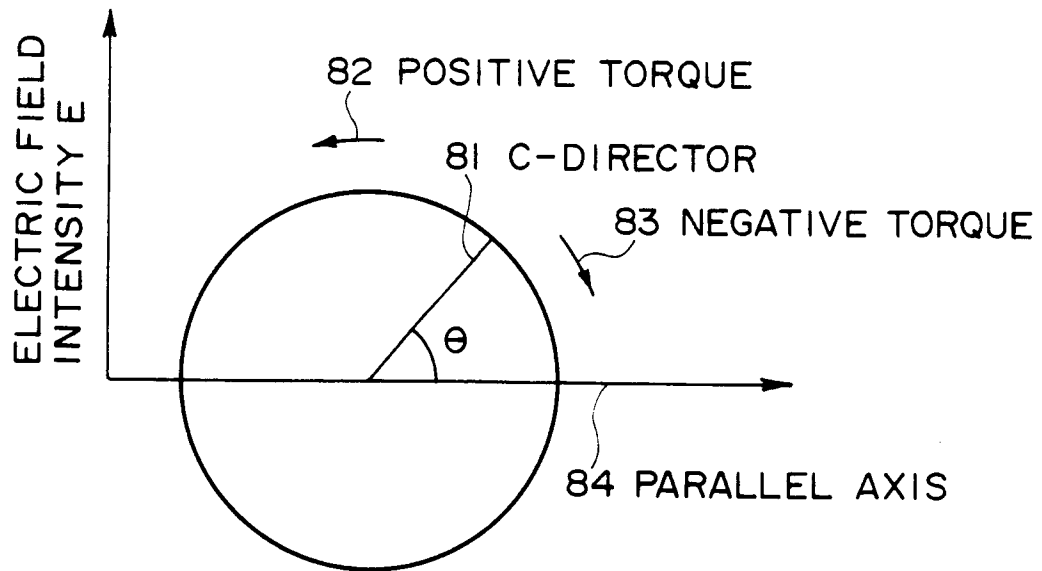

FIG. 8

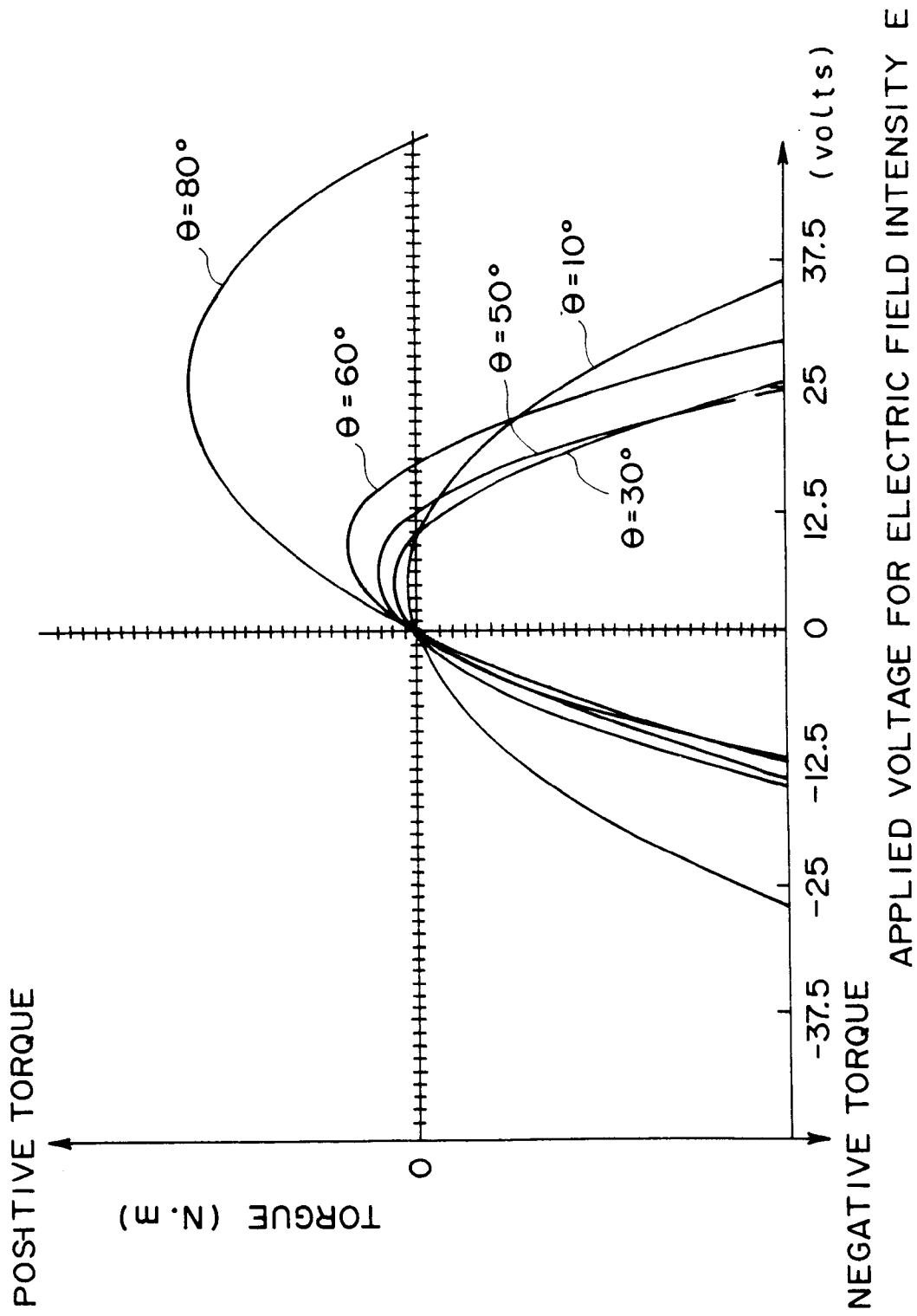

FIG. 9

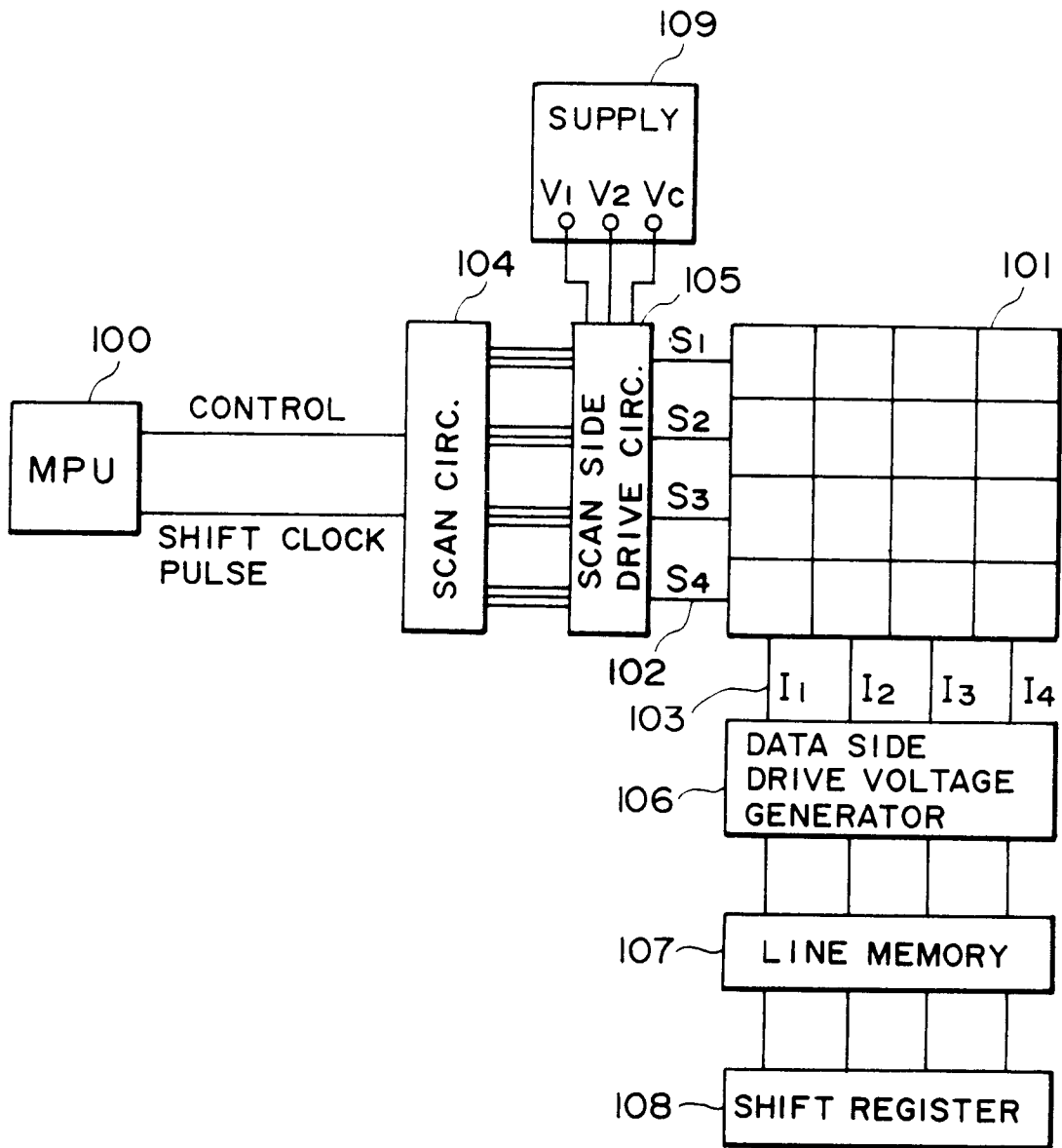

FIG. 10

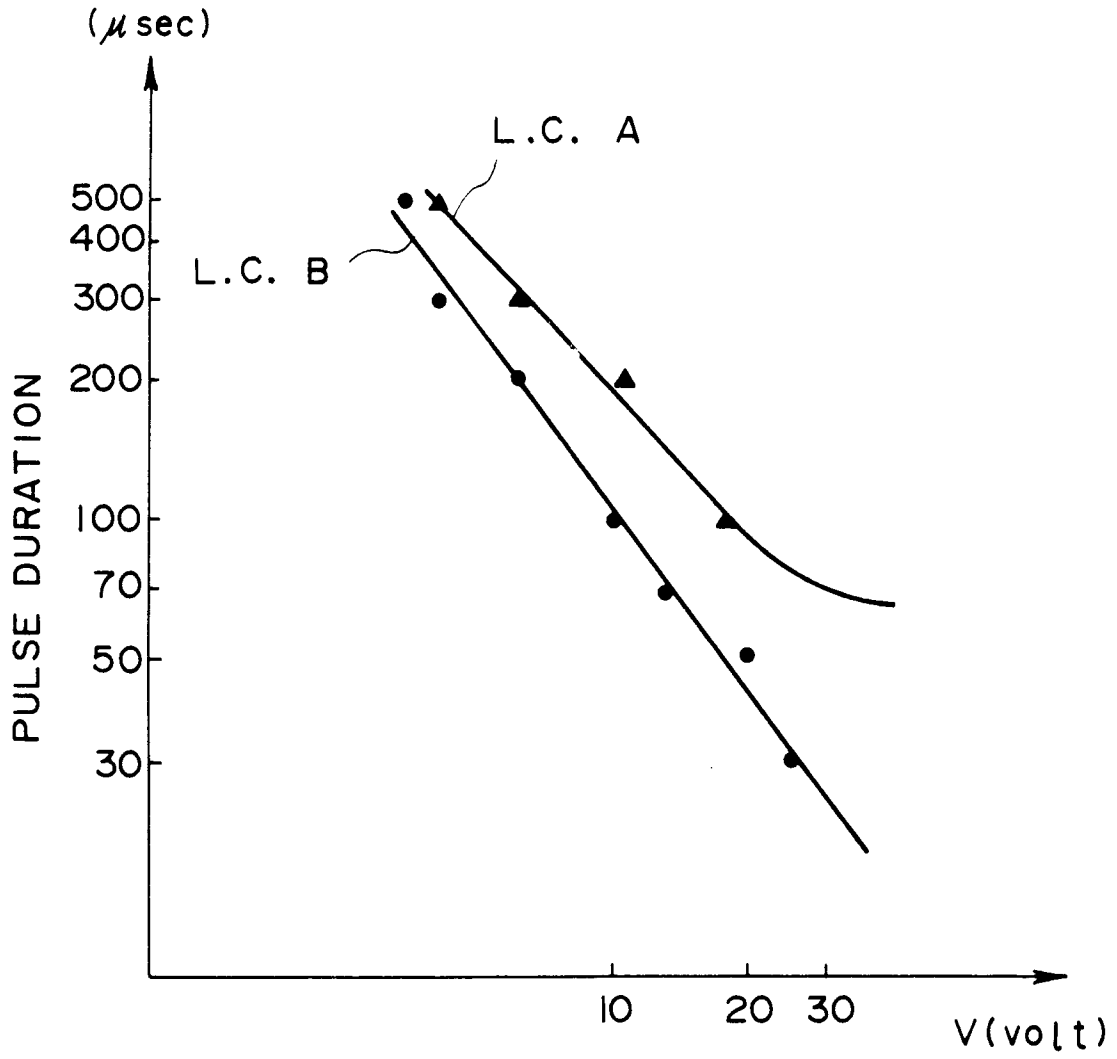
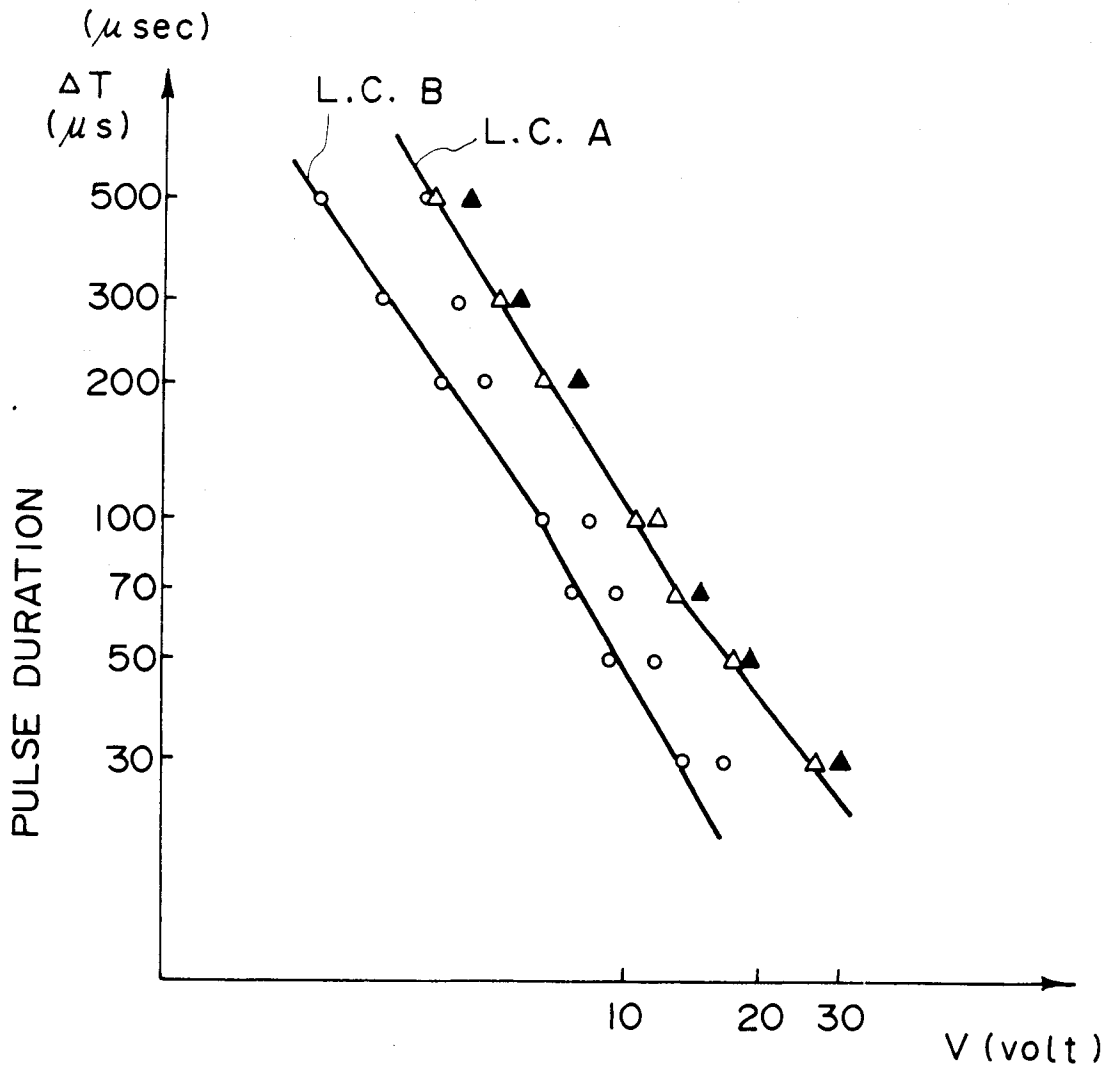

FIG. IIA



F I G. I I B