

19



Europäisches Patentamt
European Patent Office
Office européen des brevets



11 Publication number:

0 346 046 B1

12

EUROPEAN PATENT SPECIFICATION

- 45 Date of publication of patent specification: **27.10.93** 51 Int. Cl.⁵: **B41F 23/04**, F26B 13/18,
F28D 11/02
- 21 Application number: **89305651.5**
- 22 Date of filing: **05.06.89**

54 **Chill roll.**

30 Priority: **07.06.88 US 203075**

43 Date of publication of application:
13.12.89 Bulletin 89/50

45 Publication of the grant of the patent:
27.10.93 Bulletin 93/43

84 Designated Contracting States:
DE FR GB IT

56 References cited:

DE-A- 2 209 498	DE-A- 2 927 198
FR-A- 2 187 097	GB-A- 869 890
US-A- 2 915 293	US-A- 4 120 349

73 Proprietor: **W.R. Grace & Co.-Conn.**
Grace Plaza,
1114 Avenue of the Americas
New York, New York 10036-7794(US)

72 Inventor: **Moran, Kenneth J.**
1219 West Glendale
Appleton Wisconsin 54914(US)

74 Representative: **Barlow, Roy James et al**
J.A. KEMP & CO.
14, South Square, Gray's Inn
London WC1R 5EU (GB)

EP 0 346 046 B1

Note: Within nine months from the publication of the mention of the grant of the European patent, any person may give notice to the European Patent Office of opposition to the European patent granted. Notice of opposition shall be filed in a written reasoned statement. It shall not be deemed to have been filed until the opposition fee has been paid (Art. 99(1) European patent convention).

Description

BACKGROUND OF THE INVENTION

1. Field of the Invention - The present invention relates to a chill roll for cooling of printing webs, and more particularly, pertains to a chill roll with an outer roll rotating about an inner roll. Coolant is distributed evenly along the interior space between the inner and outer roll, and circulates circumferentially between the rolls to effect a uniform heat transfer across the rotating roll.

2. Description of the Prior Art -Conventional chill rolls used in the printing industry have provided for cooling of a web by passing the web over a chill roll in an effort to reduce the temperature of the web, such as a printed web, to retard ink smearing, and to reduce web temperature before it is wound on a roll.

Coolant was traditionally introduced into one side of the roll whereupon that end of the roll provided for cooling of the web adjacent to the coolant introduction area. As the coolant proceeded to the opposite end of the chill roll, the coolant temperature, as well as the web temperature across the web, increased so that the exhaust end of the roller was warmer than the introduction end of the roller. The net effect was that one edge portion of the web was cooled quite well, but the opposing edge portion was cooled substantially less due to the temperature gradient differential across the chill roll. Other existing chill roll designs featured coolant passages which were located between the outer roll shell and an inner drum, and spiraled from one side of the roll to the other side. Still other existing chill roll structures had outer and inner drums which were rotated together, and as the coolant traveled across the roll, the coolant was heated by the web so that a temperature differential still existed between the roll surface on leaving and entering the ends.

Prior art chill rolls merely pumped coolant into one end of the roll and simply forced it from the opposing end, which caused the area of the roll adjacent to the inlet to cool effectively. When the coolant picked up heat from the roll, the temperature of the area of the roll adjacent to the outlet end was much warmer than the area adjacent to the inlet. This temperature gradient across the roll would cause the web temperature to be variable in an increasing temperature differential, as well as across the roll and across the web.

Other chill roll designs depended upon an excessive coolant flow to maintain an improved and more constant temperature differential across the chill roll. The greater the flow, the smaller the temperature differential across the roll. The present invention does not require increased coolant flow to

maintain a low temperature differential because there is no differential. The same temperature exists across the roll at any given roll tangent.

The present invention overcomes the disadvantages of the prior art devices by providing a chill roll which distributes coolant in an even and uniform fashion along and across the entire length of the chill roll interior so that heat transfer is accomplished circumferentially around and about an annular space and passage between an outer rotating chill roll and a stationary roll assembly. Heat transfer is further enhanced by turbulence inducer bars causing turbulence in the coolant flow between the stationary roll and the rotary roll.

US-A-4120349 discloses a chill roll in which coolant passes along a narrow gap between (i) the internal surface of the cylindrical chill roll exterior and (ii) the external surface of a segment held stationary within that chill roll exterior, the direction of flow being such that the flow of coolant is counter-current to the direction of motion of the chill roll exterior. It is clear that this feature is only possible over a limited arc of the chill roll periphery, and there are various measures taken to confine the coolant to such a limited area and to remove any coolant which escapes from that limited area. US-A-4120349 uses stationary chill roll end journals in order to hold the chill roll inner segment stationary relative to the rotating chill roll exterior.

Claim 1 has its pre-characterising portion based on US-A-4120349.

SUMMARY OF THE INVENTION

The general purpose of the present invention is to provide a chill roll for uniform cooling across the width of an offset web. The chill roll includes a fluid flow system for delivery of coolant to an integral distribution fluid flow system contained in an inner stationary roll assembly which channels coolant from a coolant supply header, and across the longitudinal length of a chill roll. The coolant flows circumferentially in an annular space between a fixed and a rotary chill roll, and then returns through a coolant return header and return coolant exhaust.

According to the present invention, there is provided a chill roll comprising:

- (a) a cylindrical outer rotating chill roll;
- (b) cylindrical opposing first and second end roll journals supporting said chill roll and with a coolant inlet and a coolant outlet in said first and second journals, respectively;
- (c) an inner stationary roll segment presenting a cylindrical exterior surface which is of a diameter less than that of said outer chill roll to leave an annular space there-between;

characterized by

(d) the fact that there are two of said segments, namely opposing upper and lower cylindrical segments respectively secured to a coolant supply header and a coolant return header, said headers being secured about a centre tube which is supported on said end journals; by

(e) the fact that the first and second end journals are rotatable; by

(f) a plurality of holes in a coolant supply chamber in a first portion of said centre tube and a like plurality of holes in a coolant return chamber in a second portion of said centre tube; and by

(g) a plurality of holes in said coolant supply header and in said coolant return header whereby coolant flows through said first end journal, said coolant supply chamber, said coolant supply header, said space between said rolls, said coolant return header, said coolant return chamber, and out said second end journal, and whereby said stationary inner roll distributes and collects coolant across the rotating outer roll thereby evenly enhancing heat transfer.

The two end roll journals are:- a pin operator end journal and a drive end journal, each with internal passages, and they preferably extend through end plates at opposing ends of an outer rotary roll to support the bearing centre tube and stationary inner roll assembly, which encompasses the bearing centre tube. Supply coolant is introduced into the interior of the stationary inner roll through the drive end journal. The centre tube is preferably plugged at a mid-portion so as to divide the centre tube into a coolant supply chamber and a coolant return chamber. Holes in these coolant chambers connect to a coolant supply header or a coolant return header adjacent to the coolant supply and return chambers. Thrust washers and coolant-cooled carbon bearings are preferably positioned over and about the ends of the journals which extend through the rotary outer roll end plates. The centre tube, including preferably weighted inner roll assembly components, remains stationary and can free-wheel within the outer rotating chill roll assembly includes circular end discs at each end of the roll which secure to opposite ends of segmented cylindrical segments. The cylindrical segments also intersect the supply and return headers.

Fluid flow is between an annular space of the inner stationary roll and the outer rotating roll. Fluid passes through the end journal, the centre tube, the coolant supply chamber, the coolant supply header, the annular space of the rolls, the coolant return header, the coolant return chamber, and an opposing end journal. Optional turbulence inducer

bars about the cylindrical segments enhance heat transfer.

Coolant flow is distributed in a substantially equal flow along the length of the chill roll. A substantially constant temperature differential is able to be maintained between the ends of the chill roll and along the length of the chill roll. Heat transfer is further enhanced by turbulence caused by an outer roll rotating about a fixed inner roll. Heat transfer may be still further enhanced by turbulence caused by the optional turbulence inducer bars in the coolant flow on the outer surface of an inner roll, on the inner surface of an outer roll, or likewise positioned in the coolant flow.

Surface tension (between the rotating outer roll, the fixed inner roll and the interposed coolant) may move coolant by inertial feed between the rolls in the direction of rotation.

Having thus described the embodiments of the present invention, it is a principal object hereof to provide a chill roll for the cooling of an offset web or a like web member.

BRIEF DESCRIPTION OF THE DRAWINGS

Other objects of the present invention and many of the attendant advantages of the present invention will be readily appreciated as the same becomes better understood by reference to the following detailed description when considered in connection with the accompanying drawings, in which like reference numerals designate like parts throughout the figures thereof and wherein:

FIG. 1 illustrates an exploded perspective view of the major components of a chill roll;

FIG. 2 illustrates a partial cross-sectional view through the vertical axis of the chill roll;

FIG. 3 illustrates a multi-cross-sectional end view of the chill roll including half cross-sectional views through the mid-portions of the coolant supply chamber and coolant return chamber;

FIG. 4 illustrates a cross-sectional view through the vertical axis of the chill roll illustrating the center tube in plan view engaged over and about the operator end journal;

FIG. 5 illustrates the chill roll supported between bearing assemblies;

FIG. 6 illustrates a cross-sectional top view of the chill roll through the horizontal plane and an axis of the chill roll;

FIG. 7 illustrates the cross section of FIG. 3 and the flow of coolant therein; and,

FIG. 8 illustrates an alternative embodiment in cross section through the vertical axis of the chill roll.

DESCRIPTION OF THE PREFERRED EMBODIMENTS

FIG. 1 illustrates an exploded perspective view of the illustrated major components of a chill roll 10 for use in cooling a web, such as used in printing or other related fields. The chill roll 10 includes a cylindrical outer roll 12 which rotates coaxially about a cylindrical like inner roll assembly 14. The inner roll assembly 14 positions within the interior 16 of the cylindrical outer roll 12, and includes cylindrical segments 18a and 18b, each secured to the periphery of a channel like coolant supply header 20 and a channel like coolant return header 22. The coolant supply header 20 and the coolant return header 22 secure about a center tube 24. The center tube 24, the coolant supply header 20 and the coolant return header 22 include a plurality of orifices for the channeling or directing of coolant flows about the interior and exteriors of the center tube 24, the coolant supply header 20, and the coolant return header 22. A plurality of upper strengthening gussets 30a-30n and a plurality of lower strengthening gussets 32a-32n position across the coolant supply header 20 and the coolant return header 22 in the inner roll assembly 14. End discs 26 and 28 secure in a water tight manner over opposing ends of cylindrical segments 18a-18b, coolant supply header 20, coolant return header 22 and the center tube 24, each of the preceding elements being a member of the inner roll assembly 14. As described later in detail, a weight 34, resembling a cylinder segment, positions in the bottom of the inner roll assembly 14 along the length of the cylindrical segment 18b to counter any rotational tendencies of the inner roll assembly 14. A circular end cap 36, including a drive end journal 38, affixes in one end of the cylindrical outer roll 12. A removable end cap 40, which includes an operator end journal 42, secures in the opposing end of the cylindrical outer roll 12. The drive end journal 38 and the operator end journal 42 extend through end caps 36 and 40, respectively, and into opposing ends of centrally aligned center tube 24 with water cooled carbon bearings 54 and 80 interposed to support the inner roll assembly 14. A cylindrical coolant supply orifice 44, concentric within the drive end journal 38, provides a path for supply coolant to enter the inner roll assembly 14 through the center tube 24. Turbulence inducer bars 48a-48n, each being a part of the inner roll assembly 14, position longitudinally along the outer surfaces of the cylindrical segments 18a-18b. A coolant drain plug 50 locates in the removable end cap 40 to facilitate chill roll 10 drainage.

FIG. 2 illustrates a partial cross-sectional view of the support of the inner roll assembly 14 by

drive end journal 38 and operator end journal 42 taken through the vertical axis of the chill roll 10 of FIG. 1, where all numerals correspond to those elements previously described. Operator end journal 42 secures in a hole 52 and extends beyond the inner wall of the removable end 40. A shouldered water cooled carbon bearing 54 interposes between the annular surface 56 and the inner annular surface 58 of the center tube 24. A thrust washer 60 includes anti-rotational pins 62 and 64 engaged within holes 66 and 68 in the removable end cap 40, and intercedes between the water cooled carbon bearing 54 and the inner surface 40a of the removable end cap 40. Removable end cap 40 includes an annular groove 70 and an O-ring seal 72 providing a water tight seal between the removable end cap 40 and the outer roll 12. Threads 74, in the removable end cap 40, engage threads 76 on the interior of the outer roll 12. The drive end journal 38 frictionally engages within hole 78 and extends beyond the inner wall of the end cap 36. A shouldered water cooled carbon bearing 80 interposes between the annular surface 82 of the drive end journal 38 and the inner annular surface 84 of the center tube 24. A thrust washer 86 includes anti-rotational pins 88 and 90 engaged within holes 92 and 94 in the removable end cap 36. A wave washer 96 and the thrust washer 86 both interpose between the water cooled carbon bearing 80 and the inner surface 36a of the end cap 36. The center tube 24, being mounted over and being supported by drive end journal 38, operator end journal 42 and water cooled carbon bearings 80 and 54, along with its associated components including weight 34, remains stationary as the outer roll 12 is driven in rotary motion about the inner roll assembly 14 by rotational motion of the drive end journal 38. An expansion plug 100 installs in the mid-portion of the center tube 24, and divides the center tube into a coolant supply chamber 24a and a coolant return chamber 24b. The coolant supply chamber 24a includes a plurality of holes 102a-102n which port to the coolant supply header 20, which in this illustration aligns directly behind the holes 102a-102n. This mechanical relationship is illustrated in FIG. 3. Coolant return chamber 24b also includes a plurality of holes 104a-104n oriented 180° from holes 102a-102n, the location of which are illustrated in FIGS. 3 and 4. Holes 104a-104n port the coolant return header 22. The plurality of holes 102a-102n and 104a-104n substantially align in a straight path along vertical tangents of the center tube 24, and also include additional holes included in the holes 102a-102n and 104a-104n radially displaced from the vertical tangential orientation. An annular coolant passage is formed between the outer roll 12 and the inner roll assembly 14.

FIG. 3 illustrates a multi-view cross-sectional end view of the chill roll 10 including a cross section through the mid-portions of the coolant supply and return chambers 24a and 24b, and including the inner roll assembly 14 aligned in the outer roll 12 as viewed from the removable end cap 40. All numerals correspond to those elements previously described. The coolant supply header 20 includes a right angle member 110 and a planar member 112, both of which secure together at a joint 113 and to ridge areas 114 and 116 on the center tube 24. The coolant return header 22 also includes a right angle member 118 and a planar member 120, both of which secure together at a joint 115 and to ridge areas 114 and 116 on the center tube 24. The upper cylindrical segment 18a secures in an appropriate manner to the coolant supply header and return header 20 and 22 at joints 113 and 115. Additionally, joints 122 and 124 join the lower cylindrical segment 18b to the right angle members 110 and 118 of the coolant supply and return headers 20 and 22. A plurality of holes 126a-126n locate along the length of the right angle member 110 of the coolant supply header 20. Another plurality of holes 128a-128n locate along the length of the right angle member 118 of the coolant return header 22.

FIG. 4 illustrates a cross-sectional view through the vertical axis of the chill roll 10 illustrating the center tube 24 in plan view in the left portion of the illustration, and engaged over and about the operator end journal 42. All numerals correspond to those elements previously described. A portion of the plurality of holes 104a-104n located on one side of the center tube 24 are illustrated. The coolant supply chamber 24a lies directly behind the plurality of holes 104a-104n in the center tube 24. Fluid travels to the coolant return chamber 24b through the plurality of holes 104a-104n from the coolant return header 22, illustrated in FIG. 4, which abuts perpendicularly and outwardly from the center tube 24 towards the viewer of the illustration.

FIG. 5 illustrates the chill roll 10 supported for rotation between bearings 140 and 142 which are secured to side frames 144 and 146. A pulley 148 secures over the drive end journal 38 with a key 150 which engages in a keyway in the pulley 148 and a slot 152. The pulley 148 is rotated by an external motor imparting rotary motion to the outer roll 12 of the chill roll 10 while the weighted inner roll assembly 14 remains stationary. As the outer roll 12 rotates about the inner roll assembly 14, coolant is introduced and returned from the interior of the chill roll 10 through water tight rotary joints placed over and about the external portion of coolant supply and outlet orifices 44 and 46. Coolant flow is now described in detail in FIGS. 6 and 7.

MODE OF OPERATION

FIGS. 6 and 7 best illustrate the mode of operation of the chill roll 10 where all numerals correspond to those elements previously described.

FIG. 6 illustrates a cross-sectional top view through the horizontal plane and axis of the chill roll 10 illustrating longitudinal and lateral flow of coolant through the chill roll 10.

FIG. 7 illustrates a cross-sectional view of FIG. 3 illustrating circular flow of coolant 160 between the annular coolant passage 106, between the outer roll 12 and the inner roll assembly 14. It is noted that the outer roll 12 is in constant rotary motion on a common axis about the stationary inner roll assembly 14 as coolant flows through the chill roll 10. Coolant 160 is supplied to the coolant supply chamber 24a through the coolant supply orifice 44. Coolant proceeds and flows horizontally and longitudinally along the length of the coolant supply chamber 24a, and then flows horizontally and laterally through the plurality of holes 102a-102n, horizontally and laterally into the coolant supply header 20 where the uniform temperature coolant, not yet exposed to out-roll heat gradient, is uniformly directed and distributed horizontally and laterally through the plurality of holes 126a-126n and into the annular coolant passage 106.

With reference to FIG. 7, movement of uniform temperature coolant 160 from holes 126a-126n located along the length of the coolant supply header 20, and rotary motion of the outer roll 12 by means of inertial feed causes coolant 160 to circumferentially traverse along the cylindrical segment 18a of the inner roll assembly 14, and within the annular coolant passage 106 to the plurality of holes 128a-128n in the coolant return header 22. The coolant 160, with a substantially increased temperature, is collected by the coolant return header 22 through holes 128a-128n. The warmed coolant 160 is collected and passes through holes 104a-104n into the coolant return chamber 24b and overboard through the coolant outlet orifice 46. Coolant 160 is distributed uniformly along the entire length of the inner roll assembly 14 by the holes 126a-126n in the coolant supply header 20, and causes heat transfer from the outer roll 12 to the coolant 160 to be uniform across the annular coolant passage 106. A portion of the coolant proceeds full circle beyond the coolant return header 22, past and by the cylindrical segment 18b of the inner roll assembly 14, and also continues to remove heat from the outer roll 12 in a uniform fashion. The temperature across the rotating outer roll is uniformly lowered by uniform heat transfer accomplished by uniform heat removal by the coolant 160 in the annular coolant passage 106. Coolant flow turbulence is

generated between the rotating outer roll 12 and the inner roll assembly 14. Increased heat transfer occurs as the coolant 160 passes over the turbulence inducer bars 48a-48n located longitudinally along the cylindrical segments 18a and 18b. In the alternative the turbulence inducer bars 48a-48n can be located on the inner surface of the outer roll 12 to accomplish the same turbulence generation. The turbulence inducer bars 48a-48n can also be suspended in the coolant flow between the outer and inner roll assemblies.

DESCRIPTION OF THE ALTERNATIVE EMBODIMENT

FIG. 8 illustrates an alternative embodiment of a chill roll 170, where all numerals correspond to those elements previously described, featuring a solid operator end journal 172 and a drive end journal 174 with concentric supply and return passage tubes or orifices. A coolant return tube 176 is concentrically aligned in hole 178 of the drive end journal 174 and terminates in hole 180 of a plug 181, and connects to the coolant return chamber 24b. Plug 181 divides the center tube 24 into a coolant supply chamber 24a and a coolant return chamber 24b. An annular coolant supply chamber 182 locates concentrically in the drive end journal 174 between the sides of the hole 178 and about the outer circumference of the return tube 176.

In operation, coolant 160 enters the annular coolant supply chamber 182, proceeds into the coolant supply chamber 24a, and flows through holes 102a-102n, through coolant supply header 20, through holes 126a-126n, through annular coolant passage 106 circumferentially about the inner roll assembly 14 as previously described, through holes 104a-104n and into the coolant return chamber 24b. Coolant 160 proceeds from the coolant return chamber 24b through an orifice 184 in and through the return tube 176. An external rotary joint connects over the drive end journal 174 for passage of the coolant 160 in their respective directions through the annular coolant supply chamber 182 and return tube 176.

Various modifications can be made to the present invention without departing from the apparent scope of the claims. The chill roll can be used as a paper or web dryer. The chill roll can also be utilized in other applications in addition to the printing industry. The turbulence bars can be arranged in any geometrical configuration to enhance heat transfer.

Claims

1. A chill roll comprising:
 - (a) a cylindrical outer rotating chill roll (12);

(b) cylindrical opposing first and second end roll journals (38, 42; 172, 174) supporting said chill roll and with a coolant inlet (44) and a coolant outlet (46) in said first and second journals, respectively;

(c) an inner static roll segment (14) resending a cylindrical exterior surface which is of a diameter less than that of said outer chill roll to leave an annular space therebetween; characterized by

(d) the fact that there are two of said segments, namely opposing upper and lower cylindrical segments respectively secured to a coolant supply header (20) and a coolant return header (22), said headers being secured about a centre tube (24) which is supported on said end journals; by

(e) the fact that the first and second end journals are rotatable; by

(f) a plurality of holes (102a ... 102n) in a coolant supply chamber (24a) in a first portion of said centre tube and a like plurality of holes (104a ... 104n) in a coolant return chamber (24b) in a second portion of said centre tube; and by

(g) a plurality of holes (126a ... 126n; 128a ... 128n) in said coolant supply header and in said coolant return header whereby coolant flows through said first end journal (38), said coolant supply chamber (24a), said coolant supply header, said space between said rolls (12, 14), said coolant return header, said coolant return chamber (24b), and out said second end journal (42), and whereby said stationary inner roll (14) distributes and collects coolant across the rotating outer roll (12) thereby evenly enhancing heat transfer.

2. A chill roll according to claim 1 including means (48a ... 48n) for creating a high turbulence in said annular space between said rotating roll (12) and said stationary roll (14), whereby said turbulence creating means provides for enhanced heat transfer.
3. A chill roll according to claim 2 wherein said turbulence creating means are positioned on an outer surface of said inner roll.
4. A chill roll according to claim 2 wherein said turbulence means are positioned on an inner surface of said outer roll.
5. A chill roll according to any one of claims 2 to 4, wherein said turbulence means comprise turbulence inducer bars (48a ... 48n).

6. A chill roll according to any one of claims 1 to 5, wherein a first cylindrical drive end journal has a coaxial coolant inlet and outlet therein; and including a coolant return tube (176) concentrically aligned in a hole (178) of said first end journal (174) and terminating at a hole (180) in a plug (181) at a mid-portion of said centre tube (24); wherein said coolant supply chamber (24a) is between said coolant return tube and said centre tube, and said coolant supply header (20) is positioned about an outer circumference of said centre tube; and wherein said coolant return chamber (24b) is in said centre tube and between said plug (181) and said second end journal (172), and said coolant return header (22) is positioned about an outer circumference of said centre tube.

7. A chill roll according to any one of claims 1 to 6 including a weight (34) in said lower cylindrical segment (18b).

Patentansprüche

1. Kühlwalze mit:

(a) einer zylindrischen, rotierenden äußeren Kühlwalze (12);

(b) gegenüberliegenden, zylindrischen ersten und zweiten Lagerzapfen (38, 42; 172, 174), die die Kühlwalze unterstützen und mit einem Kühlmittleinlaß (44) bzw. einem Kühlmittelauslaß (46) in dem ersten bzw. dem zweiten Lagerzapfen versehen sind;

(c) einem inneren, stationären Walzensegment (14), das eine zylindrische Außenfläche aufweist, deren Durchmesser geringer ist als der der äußeren Kühlwalze, um einen ringförmigen Freiraum dazwischen freizulassen;

gekennzeichnet durch

(d) die Tatsache, daß zwei dieser Segmente vorhanden sind, nämlich gegenüberliegende untere und obere zylindrische Segmente, die jeweils an einer Kühlmittelverteilerleitung (20) und einer Kühlmittelsammelleitung (22) befestigt sind, wobei die Leitungen um ein zentrales Rohr (24) befestigt sind, das von den Lagerzapfen getragen wird; durch

(e) die Tatsache, daß die ersten und zweiten Lagerzapfen drehbar sind; durch

(f) eine Mehrzahl von Löchern (102a ... 102n) in einer Kühlmittelzufuhrkammer (24a) in einem ersten Bereich des zentralen Rohrs und einer entsprechenden Mehrzahl von Löchern (104a ... 104n) in einer Kühlmittelrückföhrkammer (24b) in einem zweiten Bereich des zentralen Rohrs; und durch

(g) eine Mehrzahl von Löchern (126a ... 126n; 128a ... 128n) in der Kühlmittelverteilerleitung und in der Kühlmittelsammelleitung, wodurch Kühlmittel durch den ersten Lagerzapfen (38), die Kühlmittelzufuhrkammer (24a), die Kühlmittelverteilerleitung, den Freiraum zwischen den Walzen (12, 14), die Kühlmittelsammelleitung, die Kühlmittelrückföhrkammer (24b) und heraus durch den zweiten Lagerzapfen (42) fließt und wodurch die stationäre innere Walze (14) Kühlmittel über die rotierende äußere Walze (12) verteilt und sammelt, wodurch die Wärmeübertragung gleichmäßig erhöht wird.

2. Kühlwalze nach Anspruch 1, mit Mitteln (48a ... 48n) zum Erzeugen einer starken Turbulenz in dem ringförmigen Freiraum zwischen der rotierenden Walze (12) und der stationären Walze (14), wodurch die Turbulenz erzeugenden Mittel eine erhöhte Wärmeübertragung schaffen.

3. Kühlwalze nach Anspruch 2, wobei die Turbulenz erzeugenden Mittel an der Außenfläche der inneren Walze angeordnet sind.

4. Kühlwalze nach Anspruch 2, wobei die Turbulenz erzeugenden Mittel an der Innenfläche der äußeren Walze angeordnet sind.

5. Kühlwalze nach einem der Ansprüche 2 bis 4, wobei die Turbulenz erzeugenden Mittel turbulenzinduzierende Stege (48a..., 48n) aufweisen.

6. Kühlwalze nach einem der Ansprüche 1 bis 5, wobei ein erster zylindrischer Antriebslagerzapfen einen koaxialen Kühlmittleinlaß und -auslaß darin aufweist; und ein Kühlmittelrückföhrrohr (176) enthält, das konzentrisch in einer Öffnung (178) des ersten Lagerzapfens (174) angeordnet ist und an einer Öffnung (180) in einem Verschlußstopfen (181) in einem mittleren Bereich des zentralen Rohrs (24) endet; wobei sich die Kühlmittelzufuhrkammer (24a) zwischen dem Kühlmittelrückföhrrohr und dem zentralen Rohr befindet und die Kühlmittelverteilerleitung (20) um den äußeren Umfang des zentralen Rohrs angeordnet ist; und wobei die Kühlmittelrückföhrkammer (24b) sich in dem zentralen Rohr und zwischen dem Verschlußstopfen (181) und dem zweiten Lagerzapfen (172) befindet, und die Kühlmittelsammelleitung (22) um den äußeren Umfang des zentralen Rohrs angeordnet ist.

7. Kühlwalze nach einem der Ansprüche 1 bis 6 mit einem Gewicht (34) in dem unteren zylindrischen Segment (18b).

Revendications

1. Tambour refroidisseur comprenant :

- (a) un tambour refroidisseur tournant externe cylindrique (12); 5
- (b) des tourillons de tambour cylindrique de première et deuxième extrémités opposés (38, 42 172, 174) supportant ledit tambour refroidisseur et avec une entrée d'agent réfrigérant (44) et une sortie d'agent réfrigérant (46) dans lesdits premier et deuxième tourillons, respectivement; 10
- (c) un segment de cylindre stationnaire interne (14) présentant une surface extérieure cylindrique dont le diamètre est inférieur à celui dudit cylindre refroidisseur externe afin de laisser subsister un espace annulaire entre ceux-ci; 15
- caractérisé par
- (d) le fait que sont prévus deux desdits segments, à savoir des segments cylindriques supérieur et inférieur opposés fixés respectivement à une tête ou extrémité d'amenée d'agent réfrigérant (20) et une tête ou extrémité de retour d'agent réfrigérant (22), lesdites têtes étant fixées autour d'un tube central (24) qui est supporté sur lesdits tourillons d'extrémité, par 20
- (e) le fait que les premier et deuxième tourillons d'extrémité sont rotatifs; par 30
- (f) une pluralité de trous (102a ...102n) dans une chambre d'amenée d'agent réfrigérant (24a) dans une première portion dudit tube central et une pluralité analogue de trous (104a ... 104n) dans une chambre de retour d'agent réfrigérant (24b) dans une deuxième portion dudit tube central ; et par 35
- (g) une pluralité de trous (126a...126n.; 128a...128n) dans ladite tête d'amenée d'agent réfrigérant et dans ladite tête de retour d'agent réfrigérant par quoi l'agent réfrigérant s'écoule à travers ledit premier tourillon d'extrémité (38), ladite chambre d'amenée d'agent réfrigérant (24a), ladite tête d'amenée d'agent réfrigérant, ledit espace entre lesdits cylindres (12, 14), ladite tête de retour d'agent réfrigérant, ladite chambre de retour d'agent réfrigérant (24b) et hors dudit deuxième tourillons d'extrémité (42), et par quoi ledit cylindre interne stationnaire (14) distribue et collecte de l'agent réfrigérant à travers le cylindre externe rotatif (12) en augmentant ainsi régulièrement un transfert de chaleur. 40 45 50

55

2. Tambour refroidisseur selon la revendication 1, comprenant des moyens (48a...48n) pour créer une turbulence élevée dans ledit espace annu-

laire entre ledit cylindre tournant (12) et ledit cylindre stationnaire (14), par quoi lesdits moyens de création de turbulence réalisent un transfert de chaleur augmenté.

3. Tambour refroidisseur selon la revendication 2, dans lequel lesdits moyens de création de turbulence sont positionnés sur une surface externe dudit cylindre interne.
4. Tambour refroidisseur selon la revendication 2, dans lequel lesdits moyens de turbulence sont positionnés sur une surface interne dudit cylindre externe.
5. Tambour refroidisseur selon l'une des revendications 2 à 4, dans lequel lesdits moyens de turbulence comprennent des barres d'induction de turbulence (48a...48n).
6. Tambour refroidisseur selon l'une des revendications 1 à 5, dans lequel un premier tourillon d'extrémité menant cylindrique possède une entrée d'agent réfrigérant coaxiale et une sortie à l'intérieur; et comprenant une tube de retour d'agent réfrigérant (176) aligné concentriquement dans un trou (178) dudit premier tourillon d'extrémité (174) et se terminant à un trou (180) dans un bouchon (181) à une portion médiane dudit tube central (24); dans lequel ladite chambre d'amenée d'agent réfrigérant (24a) se trouve entre ledit tube de retour d'agent réfrigérant et ledit tube central, et ladite tête d'amenée d'agent réfrigérant (20) est positionnée autour d'une circonférence externe dudit tube central; et dans lequel ladite chambre de retour d'agent réfrigérant (24b) est dans ledit tube central entre ledit bouchon (181) et ledit deuxième tourillon d'extrémité (172), et ladite tête de retour d'agent réfrigérant (22) est positionnée autour d'une circonférence externe dudit tube central.
7. Tambour refroidisseur selon l'une des revendications 1 à 6, comprenant un poids (34); dans ledit segment cylindrique inférieur (18b).

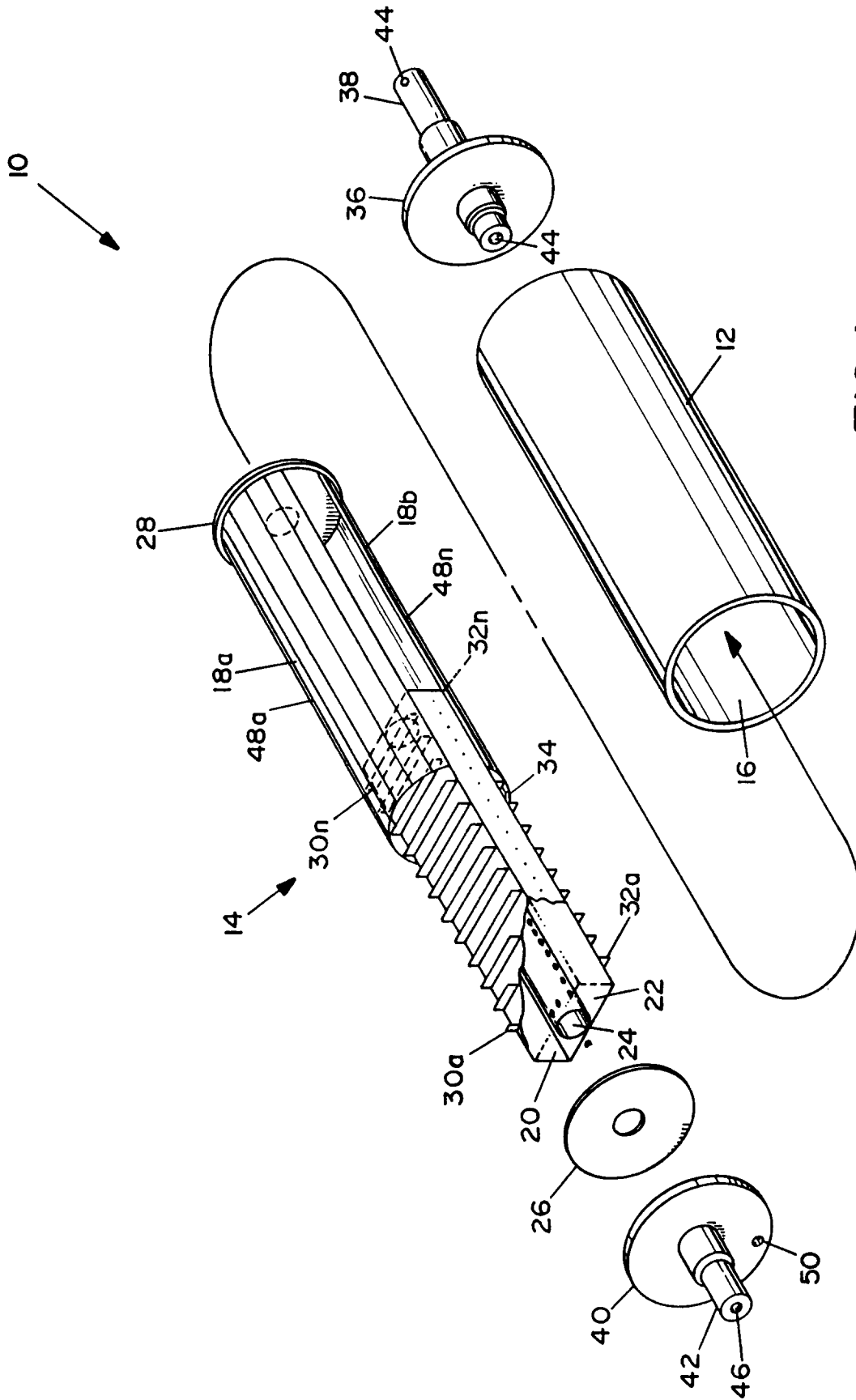

FIG. 1

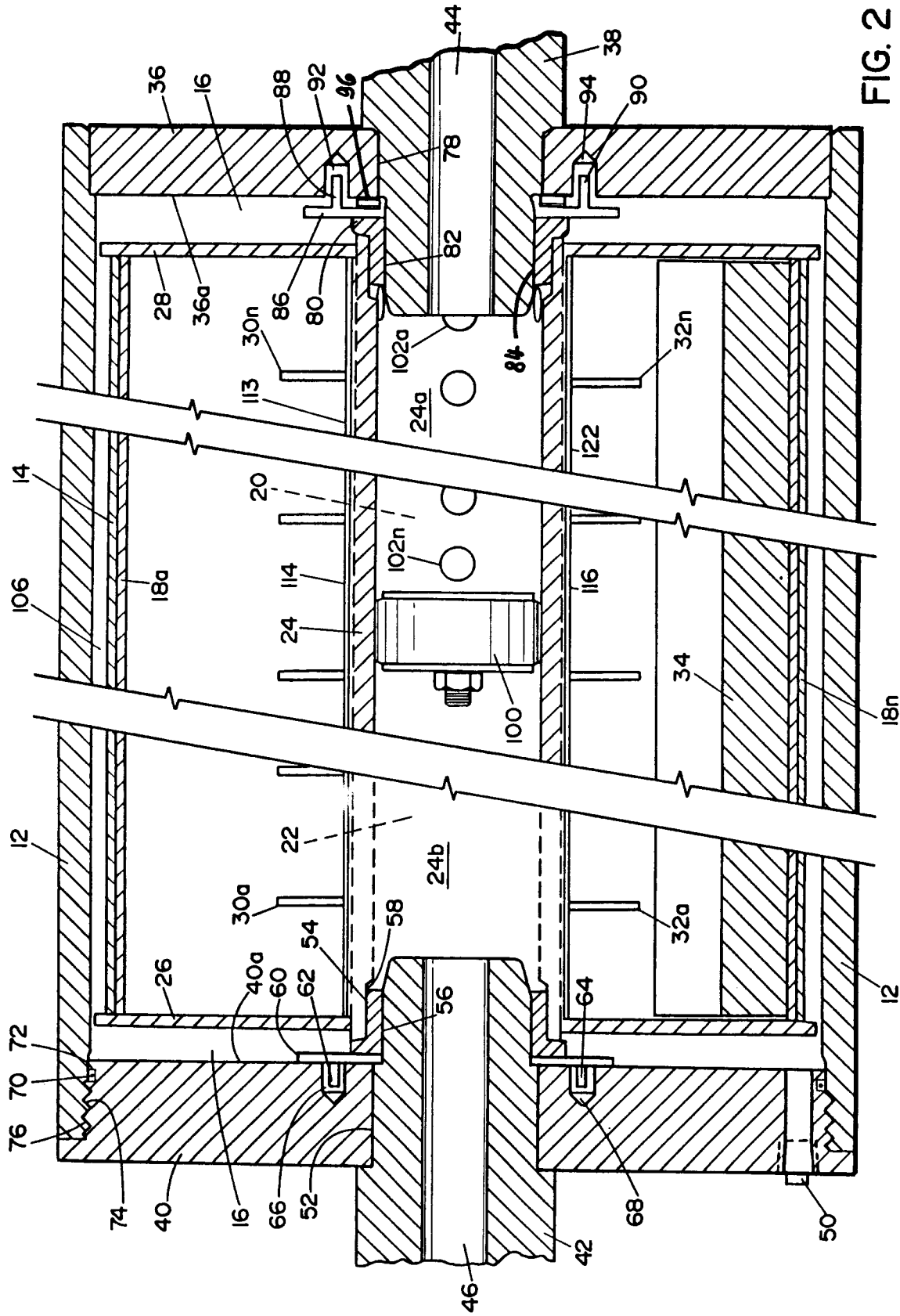

FIG. 2

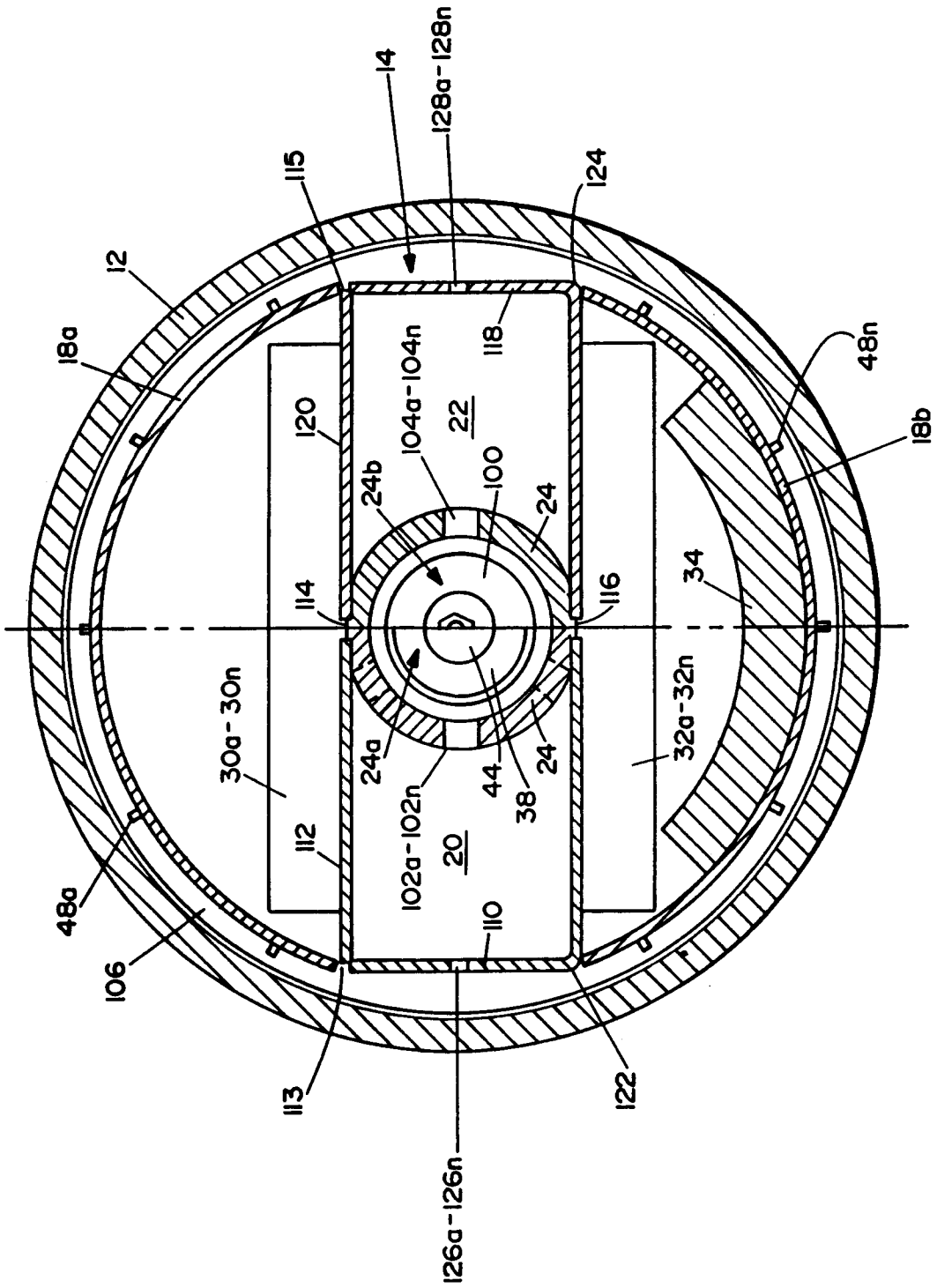

FIG. 3

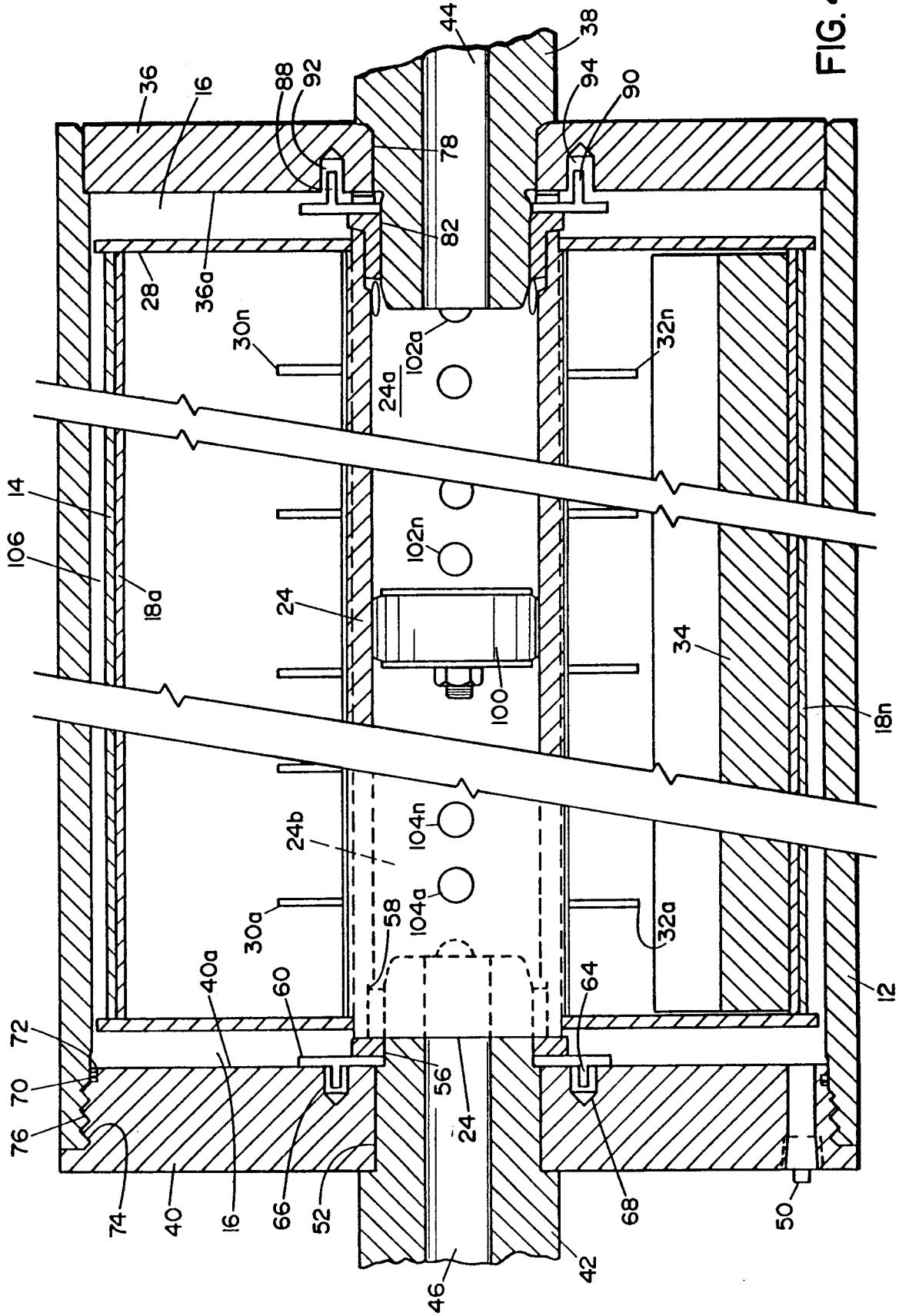

FIG. 4

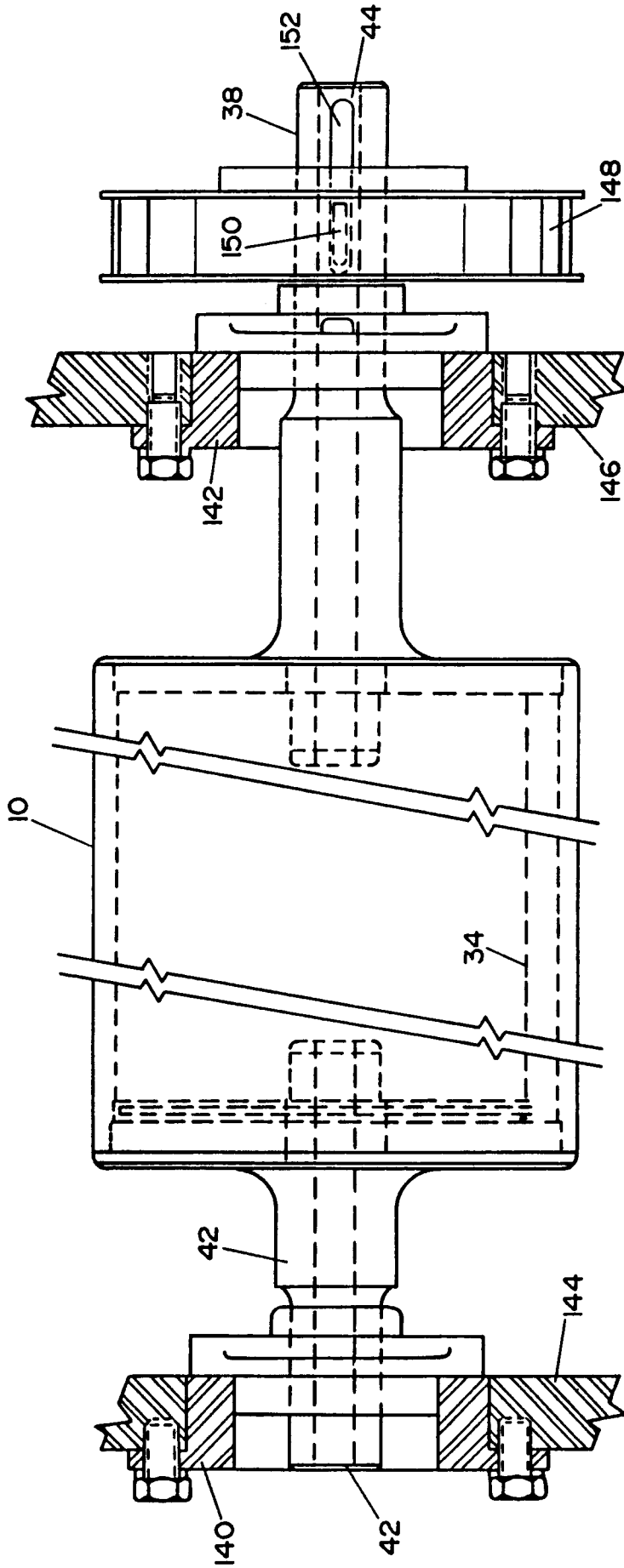

FIG. 5

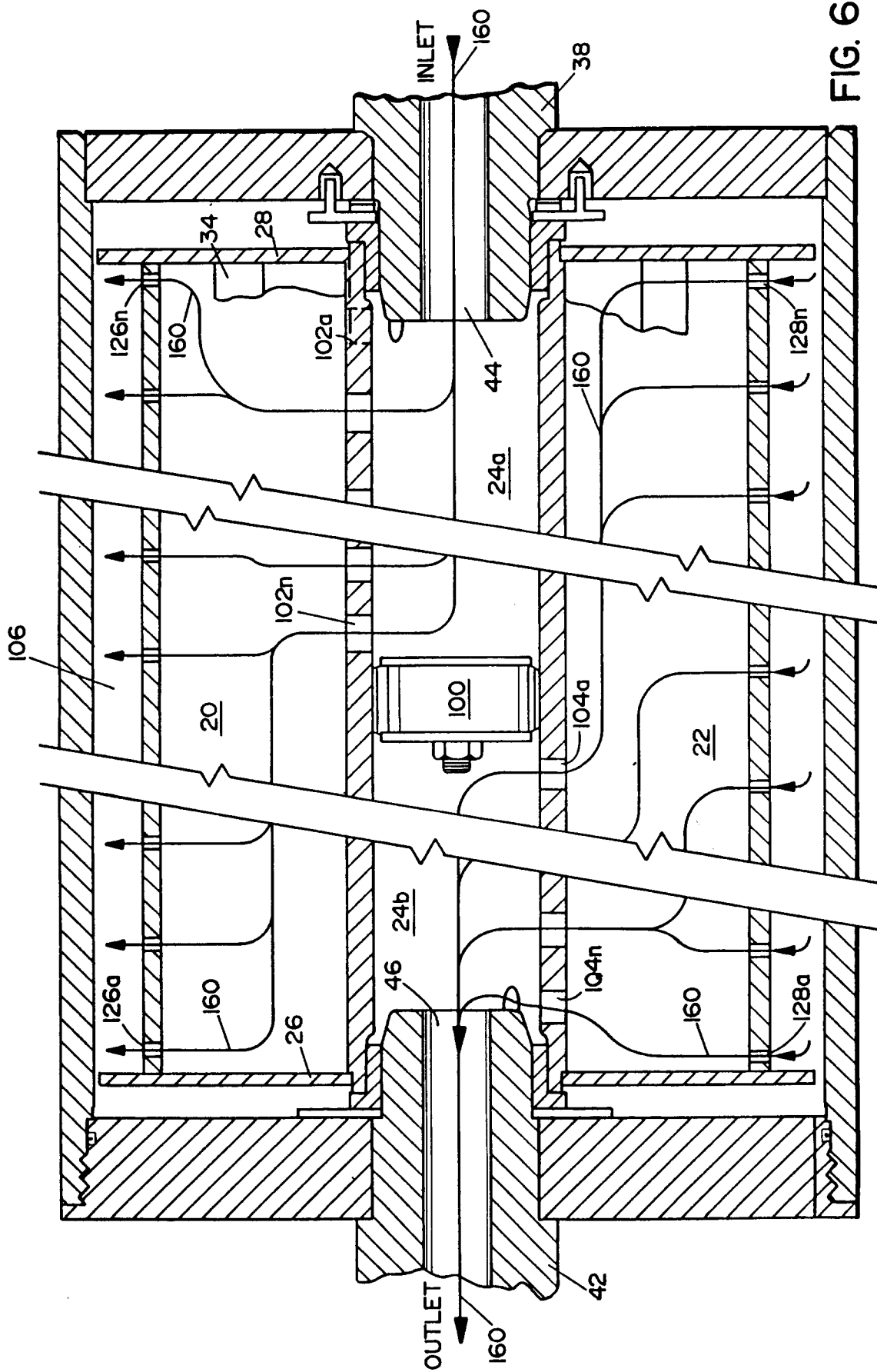

FIG. 6

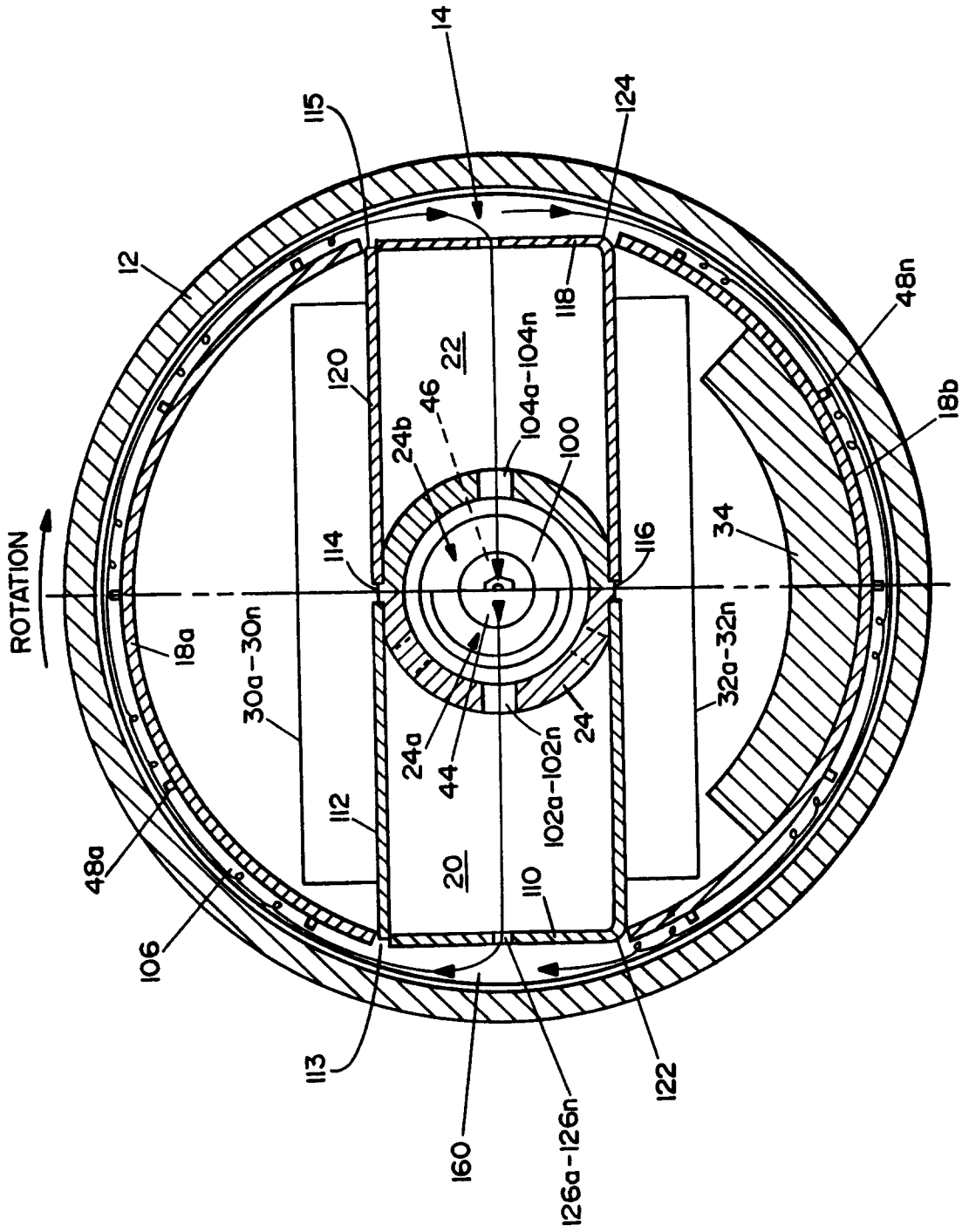

FIG. 7

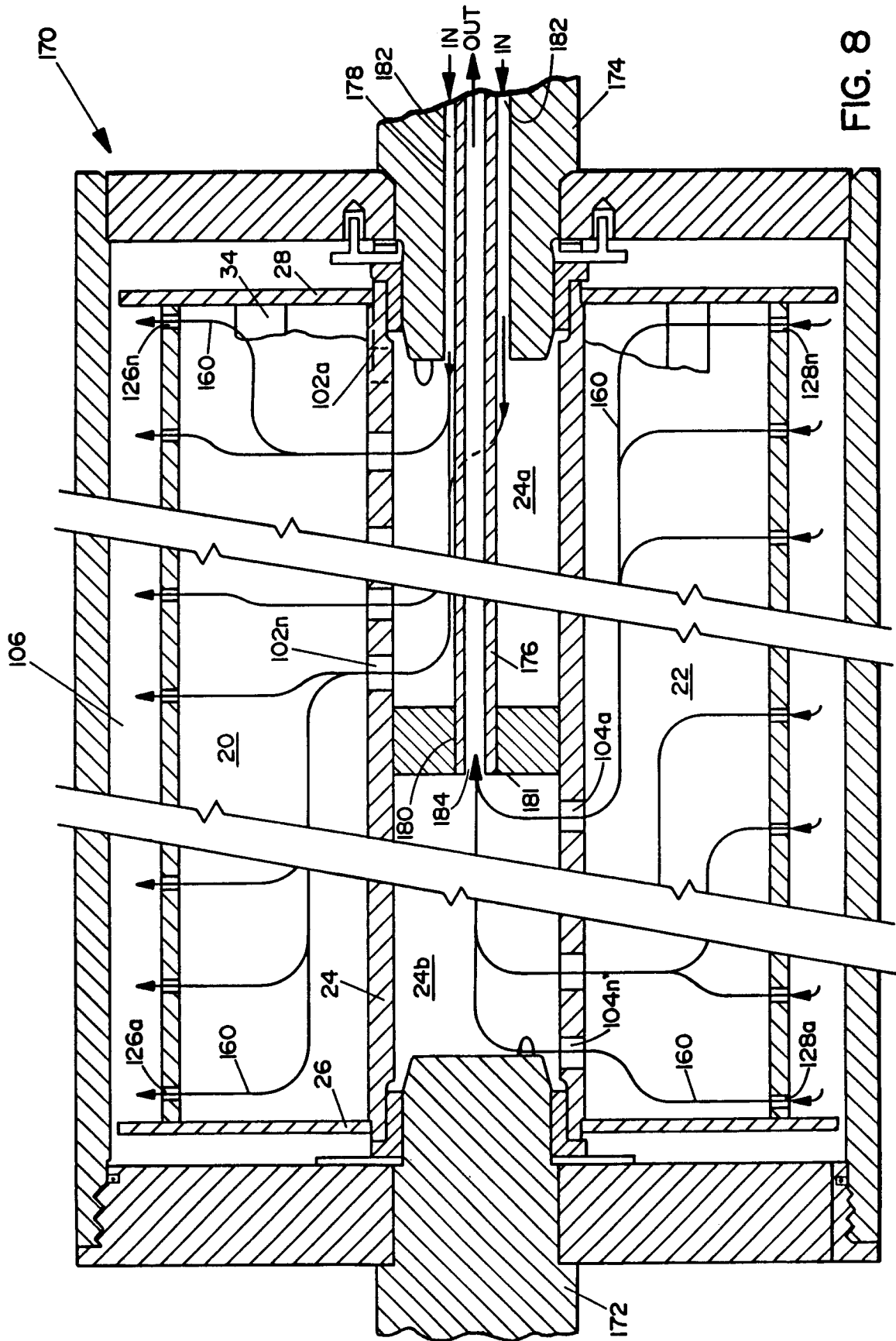

FIG. 8