

**EUROPEAN PATENT APPLICATION**

Application number: 89202953.9

Int. Cl.<sup>5</sup>: **B21D 19/08**

Date of filing: 21.11.89

Priority: 22.11.88 NL 8802876

Date of publication of application:  
30.05.90 Bulletin 90/22

Designated Contracting States:  
AT BE CH DE ES FR GB IT LI NL SE

Applicant: **van der Goot, Arnold**  
**Voorbroek 9**  
**NL-7061 GC Terborg(NL)**

Inventor: **van der Goot, Arnold**  
**Voorbroek 9**  
**NL-7061 GC Terborg(NL)**

Representative: **Lips, Hendrik Jan George, Ir.**  
**et al**  
**HAAGSCH OCTROOIBUREAU Breitnerlaan**  
**146**  
**NL-2596 HG Den Haag(NL)**

**Device for bending the rim of a sheet.**

Device for bending the rim (10) of a sheet (9,53), said device comprising a bending roll (7,50), a support block (11,48) for the bending roll, a forming die (6,46) against which the rim of the sheet (9,53) to be bent can be pressed by means of the bending roll (7,50) and a framework (1,42) serving to support the forming die (6,46) on the one hand and means for bringing the support block with the bending roll (7,50) towards the forming die (6,46), said framework (1,42) being executed substantially U-shaped, the opposite end portions of the legs (4,5; 44,45) of it serving to support the forming die (6,46) and the support block for moving the bending roll (7,50) towards the forming die respectively, said support block (11,48) being provided pivotally or slidably in respect of the web (3,43) of the U-shaped framework (1,42), said support block (11,48) extending over the whole length of the rim of the sheet (9,53) to be bent. Said framework (1,42) can be composed from substantially U-shaped lamellae (2) being provided with holes (25,26,27) in which rods (28,29,34,35) are mounted for holding said lamellae together.

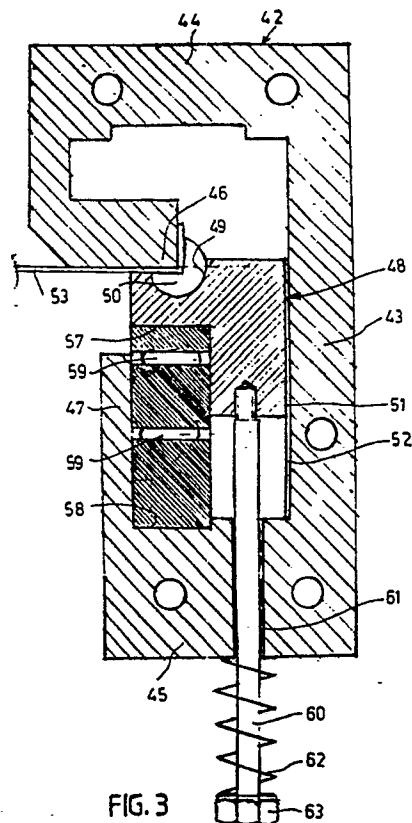

FIG. 3

EP 0 370 582 A1

### Device for bending the rim of a sheet.

The invention relates to a device for bending the rim of a sheet, said device comprising a bending roll in the shape of a cylindrical roll from which a segment is removed, in which segment a rim of a sheet can be pressed which has to be bent, a support for the bending roll by which the bending roll is supported over a part of its circumference, a forming die against which the rim of the sheet to be bent can be pressed by means of the bending roll, means for pressing the bending roll towards the forming die and a framework serving to support the forming die on the one hand and the means for bringing the bending roll towards the forming die and guiding the bending roll on the other hand.

Such a device is known from US-A-4,002,049. In case of this known device use is made of a press, the forming die being connected to the lower stationary portion of the press, the bending roll being connected to the upper portion. Now forces are exerted during bending the rim of a sheet in a direction transverse to the axis of the bending roll, which forces in one way or another will have to be absorbed by those portions of the press extending in vertical direction. This will give no problems when either a sufficiently heavy press is available so that the transverse force can be absorbed without deformations or the press being executed such that the deformations will be equal over the whole length of the sheet to be bent. Such a press, however, will be relatively expensive and so, generally speaking, will not be bought for this purpose.

In view of this the object of the invention is to provide a device which is simple of construction and in which the deformations of the framework will be equal over the whole length of a sheet to be bent by which an exact bending of the rim of a sheet can be executed.

According to the invention this is obtained because the framework is executed substantially U-shaped, the opposite end portions of the legs of the U-shaped framework serving to support the forming die and the means for moving the bending roll towards the forming die respectively, the bending roll being supported by a support block being provided pivotally or slidably in respect of the web of the U-shaped framework such that the force which during the bending of a sheet is exerted to the support block and is directed transverse to the direction of movement of said block, is absorbed by the web of said framework, said framework, said support block and the means for moving said support block towards said forming die extending themselves over the whole length of the rim of the sheet to be bent.

In this way a very stable construction is obtained in which a deformation, if any, of the U-shaped framework extends itself equally over the total length of the sheet to be bent, so that the rim of the sheet will have exactly the same cross-section over its whole length.

According to an embodiment the support block will be in the shape of a support arm one end of which is pivotally connected to the web of the framework, the other end being provided with a cavity for supporting the forming die and with a cavity provided in the opposite surface for pivotally receiving the end of at least one lever, the other end of which is pivotally connected to the one end of a second lever, the other end of which is pivotally supported by the leg of the U-shaped framework, such that said two levers together are forming an angle lever system, a driving mechanism acting on at least one of said lever systems.

In doing so it can be provided that the support arm and the levers of the angle lever system are supported by said framework in such a way that the components of the forces acting upon the end of the support arm by the bending roll on the one hand and by the angle lever system on the other hand, which components are running in a plane transverse to the plane in which the axes of the two cavities in said support arm are positioned, are oppositely directed. This contributes to a favourable dimensioning of the support arm and of the framework.

According to another embodiment the support block is movable in a direction parallel to the web of the U-shaped framework and normal to the plane of a sheet which has to be bent, said support block being comprised between two opposite parallel running surfaces of said web and of an upwardly protruding extension of the leg of the framework respectively.

For bringing said support block upwardly for bending a sheet use can be made of at least one set of elongated wedge shaped activating strips which together are forming a block with opposite parallel surfaces which are engaging a surface of the support block and of the lower leg of the U-shaped framework respectively such that by moving said strips lengthwise the surfaces of support block and of the framework leg are pressed away from each other.

In order to prevent that the support block during its movement for bending a sheet is also moved in a direction parallel to the plane of said sheet, the support block can be guided by rods running normal to the plane of the sheet and being connected to either the support block or the frame-

work and extending into a bore in the other part. In particular the rods will be partly provided with a screwthread for being screwed into the support block, the other end of said rods extending downwardly through a bore in the framework leg, a spring being provided between the end of a rod and said leg to bring the support block downwardly after the bending of a sheet.

According to a further elaboration of the invention it can be provided that the framework is composed from substantially U-shaped lamellae being provided with holes running transverse to the plane of said lamellae through which holes parallel running rods can be slid for holding said lamellae together.

Said lamellae can be obtained in a simple way by means of stamping or by another suitable operation and a number of lamellae can be joined to obtain the desired length of the frame work. By this it is obtained that after bending two rims of a sheet also another rim of the sheet can be bent which rim is crossing the already bent rims eventually at right angles because the framework can be adjusted to the distance between the two primary bent rims and so to the length of the rim which still has to be bent.

According to a preferred embodiment a number of lamellae in particular almost half the total number of lamellae will be connected to a fixed package by means of at least one of the rods and the other lamellae will be movable in respect of said package by means of two aligned screwed rods which are longitudinally movable in respect of each other but are rotatably coupled with each other, said rods extending through screwthread provided in holes in said lamellae, the length of one of said screwed rods being at least equal to the total thickness of all lamellae.

So when the one screwed rod extends itself through all lamellae the framework is having its maximum length. When the framework has to be made shorter, said screwed rod is screwed out of a number of lamellae, the aligned screwed rod simultaneously being screwed into the lamellae. When now the desired thickness of the package is obtained said screwed rods can be pulled somewhat from each other so that two separate packages of lamellae are obtained which are somewhat spaced from each other. So the thickness of the package of lamellae which has to be used substantially can be each multiple of the thickness of one single lamella.

Obviously the possibility exists to compose the support block and the other part of the device also from lamellae.

In this way the length of a device can be adjusted as much as possible to the length which is desired.

Now the invention is further described by means of embodiments, shown in the drawing, in which:

Fig. 1 is showing an end view of a device according to the invention as seen in the direction of the bending line;

Fig. 2 shows a side view of the device of fig. 1;

Fig. 3 shows a cross-section of a modified embodiment of a device according to the invention, partly according to the line III-III of fig. 4; and

Fig. 4 shows a cross-section of a detail of the device according to fig. 3.

The device shown in the figs. 1 and 2 comprises the mainly U-shaped framework 1 composed from lamellae 2. A lamella 2 consists of the web 3 and the legs 4 and 5. The leg 4 extends into the forming die 6 opposite which the bending roll 7 is lying consisting from a cylindrical portion from which a segment 8 is removed. Between the forming die 6 and the bending roll 7 a sheet 9 can be brought from which the rim 10 can be bent by pressing the bending roll 7 towards the forming die 6.

The bending roll 7 is supported by the support arm 11, a surface 12 of which is provided with a cavity 13, the opposite surface 14 being provided with a cavity 15 for pivotally receiving one end 16 of a lever 17, the other end 18 of which is pivotally connected with the end 19 of a lever 20, the other end 21 of which is pivotally supported by a cavity 22 in the legs 5 of the lamellae 2. The support arm 11 is pivotally received in a cavity 23 in the framework 1.

The levers 17 and 20 together are forming an angle lever which can be operated by pressurized medium cylinders 24, e.g. one at each end of the framework. By means of said cylinders 24 e.g. the pivot between the levers 17 and 20 can be moved in the direction of the arrow P in fig. 1, by which the arm 11 will be pivoted such that the bending roll 7 will be moved towards the forming die 6 and the rim 10 of the sheet 9 will be bent.

The lamellae 2 are provided with holes 25, 26 and 27. As in particular appears from fig. 2 rods 28 and 29 are extending through the holes 25 and 26 respectively. Almost half the number of lamellae is enclosed between thickened portions 30 of the rods 28 and 29, such that these lamellae are forming one package 31.

From the other free lamellae 2 a desired number can be added to the package 31. In fig. 2 this is one lamella, the further lamellae together forming one package 32. To this end the hole 27 of each lamella is provided with screwthread 33. The pitch of this screwthread preferably is equal to the thickness of one lamella. A first screwed rod 34 is running through the screwthread 33, the length of

which rod is at least equal to the total thickness of all lamellae. The screwed rod 35 is extending in line with the screwed rod 34, the rods 34 and 35 being coupled by means of a hexagon 36, connected to one of the screwed rods and extending in a fitting cavity in the other screwed rod. So the screwed rods 34 and 35 can be slid apart somewhat at the position of the hexagon 36 but will together being rotated as by means of a crank connected to the screwed rod 35.

To move the screwed rods 34 and 35 away from each other and towards each other, a nut 38 is provided on the screwed rod 35, said nut being provided with sideways extending pins 39. Said pins 39 cooperate with a lever 40 in a not further shown way, one end 41 of said lever 40 being pivotally supported by means of the rod 28.

In the position shown in fig. 2 the screwed rod 34 extends itself through the lamellae package 31, lying between the two thickened portions 30 of the rods 28 and 29 and through one further lamella 2, the screwed rod 35 extending itself through the other lamellae to form the package 32. By means of the lever 40 the packages 31 and 32 are somewhat pulled apart so that the device can be used for bending the rim of a sheet from which the two rims running at a right angle to said rim are already provided with a bent portion.

To protect the surface of the sheet 9 against damaging by the bending roll 7 a not shown protecting sheet can be applied between the bending roll 7 and the sheet 9 which protecting sheet only needs to have a small thickness.

In case of the embodiment of the device according to the invention shown in the figs. 3 and 4, said device again comprises a mainly U-shaped framework 42 comprising the web 43, the upper leg 44 and the lower leg 45. The upper leg 44 extends in the forming die 46, the lower leg 45 being provided with an upwardly extending portion 47. A support block 48 is provided with a cavity 49 in which the bending roll 50 is received.

The surface 51 of the support block 48 engages the web 43 of the framework 42. A bearing sheet 52 can be provided between the surface 51 and the web 43.

The support block 48 together with the bending roll 50 are shown in the position after bending a sheet 53 so in the uppermost position.

The vertical movement of the support block 48 is obtained by using elongated wedge shaped strips 54 forming blocks 55 with opposite parallel surfaces 56, one of which is engaging a surface 57 of the support block 48 and the other is engaging a surface 58 of the lower leg 45 of the framework 42. Between the strips 54 rolls 59 can be provided to decrease the frictional forces when moving the strips 54 in respect of each other. Either the lower

strips 54 can be stationary in respect of the framework 42 or the upper strips 54 can be stationary in respect of the support block 48. Between the other engaging surfaces also rolls can be provided for decreasing the friction between said surfaces when moving the related strips 54.

When a sheet 53 has to be bent the support block 48 will be in a lower position than indicated in fig. 3, in which position the bending roll 50 can be in the position as shown in fig. 1. After bringing the sheet 53 between the bending roll 50 and the forming die 46, a strip 54 e.g. the upper strip 54 is moved in the direction of the arrow R in fig. 4, so that the upper strips 54 will reach the position as shown in this figure. The movement of the strip 54 e.g. can take place by means of a pressurized medium cylinder, which is not further shown. During the movement of the strip 54 the bending roll 50 is bending the rim of the sheet 53 till the position of the bending roll 50, shown in fig. 3, is reached.

Then the strips 54 are moved in the direction opposite to that of the arrow R. To bring the support block 48 downward, said block can be connected to bolts 60 extending through an opening 61 in the lower leg 45 of the framework 42. A spring 62 can be provided around the bolt 60, engaging the head 63 of the bolt 60 on the one hand and the lower leg 45 on the other hand. The bolts 60 also can serve to prevent moving of the support block 48 in the direction of movement of the upper strips 48. This object also can be achieved by providing the framework with end-strips.

Just as in case of the embodiment according to fig. 1, between the bending roll 50 and the sheet 53 a protecting sheet can be provided to prevent damage of the sheet 53. Also between other engaging surfaces being moved in respect of each other, bearing sheets or rollers can be provided to decrease frictional forces and wear.

Obviously only some possible embodiments of the device according to the invention are shown in the drawing and are described above. Many modifications can be provided without leaving the inventive concept.

## Claims

1. Device for bending the rim (10) of a sheet (9,53), said device comprising a bending roll (7,50) in the shape of a cylindrical roll from which a segment (8) is removed, in which segment (8) a rim of a sheet can be pressed, which has to be bent, a support (11,48) for the bending roll by which the bending roll is supported over a part of its circumference, a forming die (6,46) against

which the rim of the sheet (9,53) to be bent can be pressed by means of the bending roll (7,50), means for pressing the bending roll towards the forming die (6,46) and a framework (1,42) serving to support the forming die (6,46) on the one hand and the means for bringing the bending roll (7,50) towards the forming die (6,46) and guiding the bending roll on the other hand, characterized in

that the framework (1,42) is executed substantially U-shaped, the opposite end portions of the legs (4,5; 44,45) of the U-shaped framework serving to support the forming die (6,46) and the means for moving the bending roll (7,50) towards the forming die respectively, the bending roll (7,50) being supported by a support block (11,48) being provided pivotally or slidably in respect of the web (3,43) of the U-shaped framework (1,42) such that the force which during the bending of a sheet (9,53) is exerted to the support block (11,48) and is directed transverse to the direction of movement of said block, is absorbed by the web (3,43) of said framework, said framework (1,42), said support block (11,48) and the means for moving said support block towards said forming die (6,46) extending themselves over the whole length of the rim of the sheet (9,53) to be bent.

2. Device according to claim 1, characterized in

that the support block is having the shape of a support arm (11) one end (23) of which is pivotally connected to the web (3) of the framework (1), the other end (12) being provided with a cavity (13) for supporting the forming die (7) and with a cavity (15) provided in the opposite surface (14) for pivotally receiving the end (16) of at least one lever (17), the other end (18) of which is pivotally connected to the one end (19) of a second lever (20), the other end (21) of which is pivotally supported by the leg (5) of the U-shaped framework (1), such that said two levers (17,20) together are forming an angle lever system, a driving mechanism (24) acting on at least one of said lever systems (17,20).

3. Device according to claim 2, characterized in

that the support arm (11) and the levers (17,20) of the angle lever system are supported by said framework (1) in such a way that the components of the forces acting upon the end of the support arm (11) by the bending roll (7) on the one hand and by the angle lever system (17,20) on the other hand, which components are running in a plane transverse to the plane in which the axes of the two cavities (13,15) in said support arm (11) are positioned, are oppositely directed.

4. Device according to claim 1, characterized in

that the support block (48) is movable in a direction

parallel to the web (43) of the U-shaped framework (42) and normal to the plane of a sheet (53) which has to be bent, said support block (48) being comprised between two opposite parallel running surfaces of said web (43) and of an upwardly protruding extension (47) of the leg (45) of the framework (42) respectively.

5. Device according to claim 4, characterized in

that for bringing said support block (48) upwardly for bending a sheet (53) use is made of at least one set of elongated wedge shaped activating strips (54) which together are forming a block (55) with opposite parallel surfaces (56) which are engaging a surface (57,58) of the support block (48) and of the lower leg (45) of the U-shaped framework (42) respectively such that by moving said strips lengthwise the surfaces of support block (48) and of the framework leg (45) are pressed away from each other.

6. Device according to claim 4 or 5, characterized in

that the support block (48) is guided by rods (60) running normal to the plane of the sheet (53) and being connected to either the support block (48) or the framework (42) and extending into a bore (61) in the other part.

7. Device according to claim 6, characterized in

that the rods (60) are partly provided with a screwthread for being screwed into the support block (48), the other end of said rods extending downwardly through a bore (61) in the framework leg (45), a spring (62) being provided between the end (63) of a rod (60) and said leg (45) to bring the support block (48) downwardly after the bending of a sheet (53).

8. Device according to one of the preceding claims,

characterized in

that the framework (1,42) is composed from substantially U-shaped lamellae (2) being provided with holes (25,26,27) running transverse to the plane of said lamellae through which holes parallel running rods (28,29,34,35) can be slid for holding said lamellae together.

9. Device according to claim 8, characterized in

that a number of lamellae (2) in particular almost half the total number of lamellae is connected to a fixed package (31) by means of at least one of the rods (28,29) and that the other lamellae will be movable in respect of said package (31) by means of two aligned screwed rods (34,35) which are longitudinally movable in respect of each other but are rotatably coupled with each other, said rods extending through screwthread (33) provided in holes (27) in said lamellae (2), the length of one of

said screwed rods (34) being at least equal to the total thickness of all lamellae (2).

10. Device according to claim 8 or 9, characterized in that the support block (11,48) and other parts of the device are also composed from lamellae. 5

10

15

20

25

30

35

40

45

50

55

6

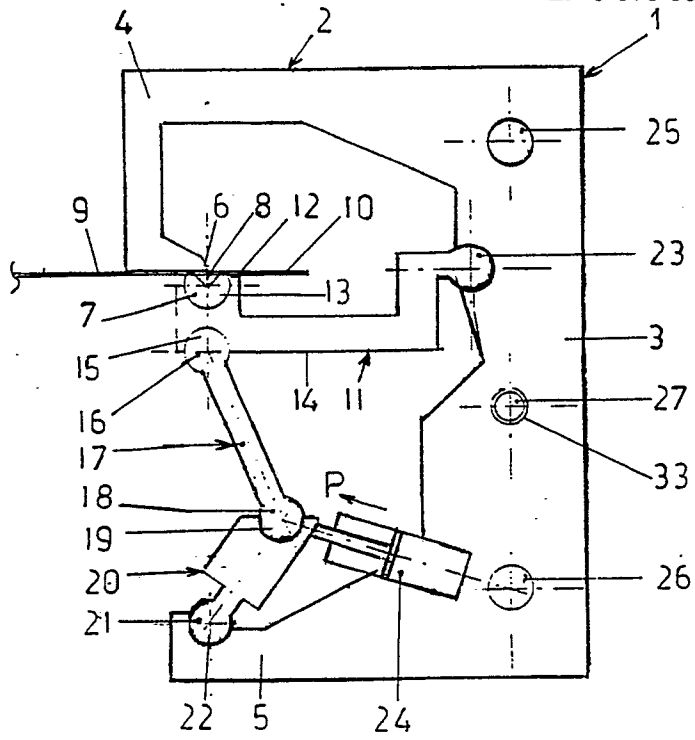

FIG. 1

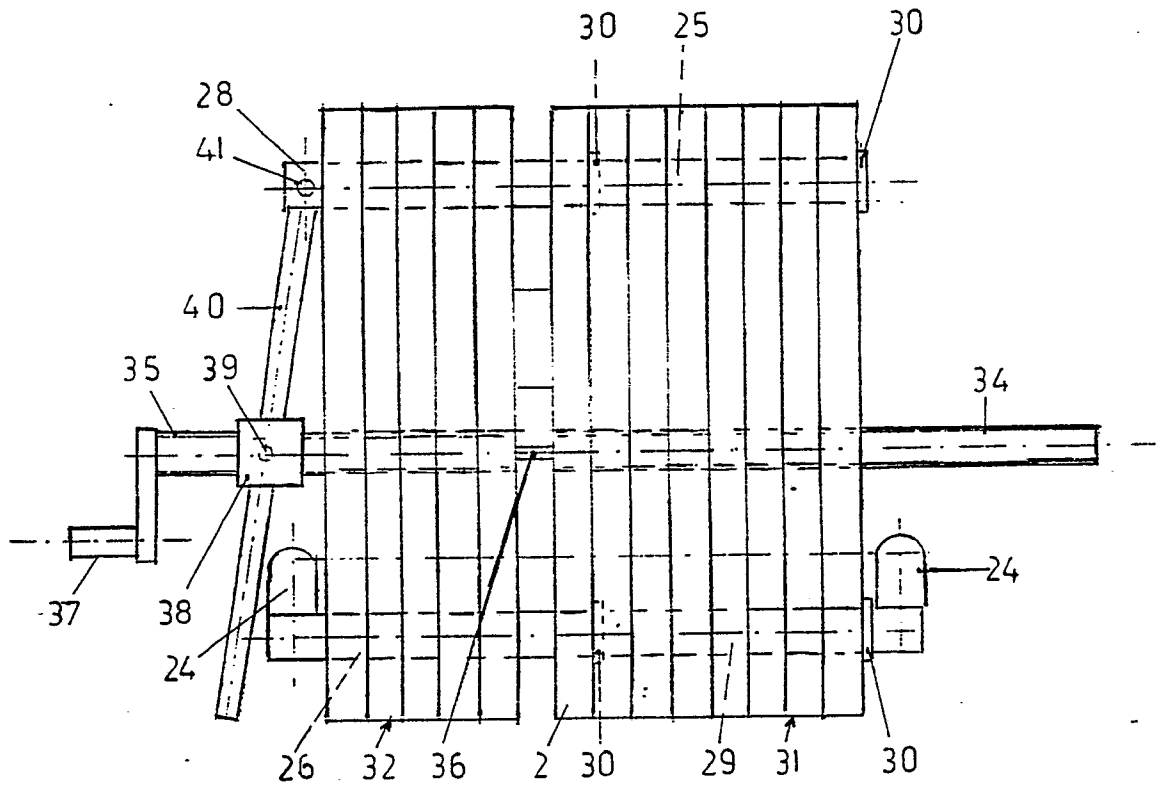

FIG. 2

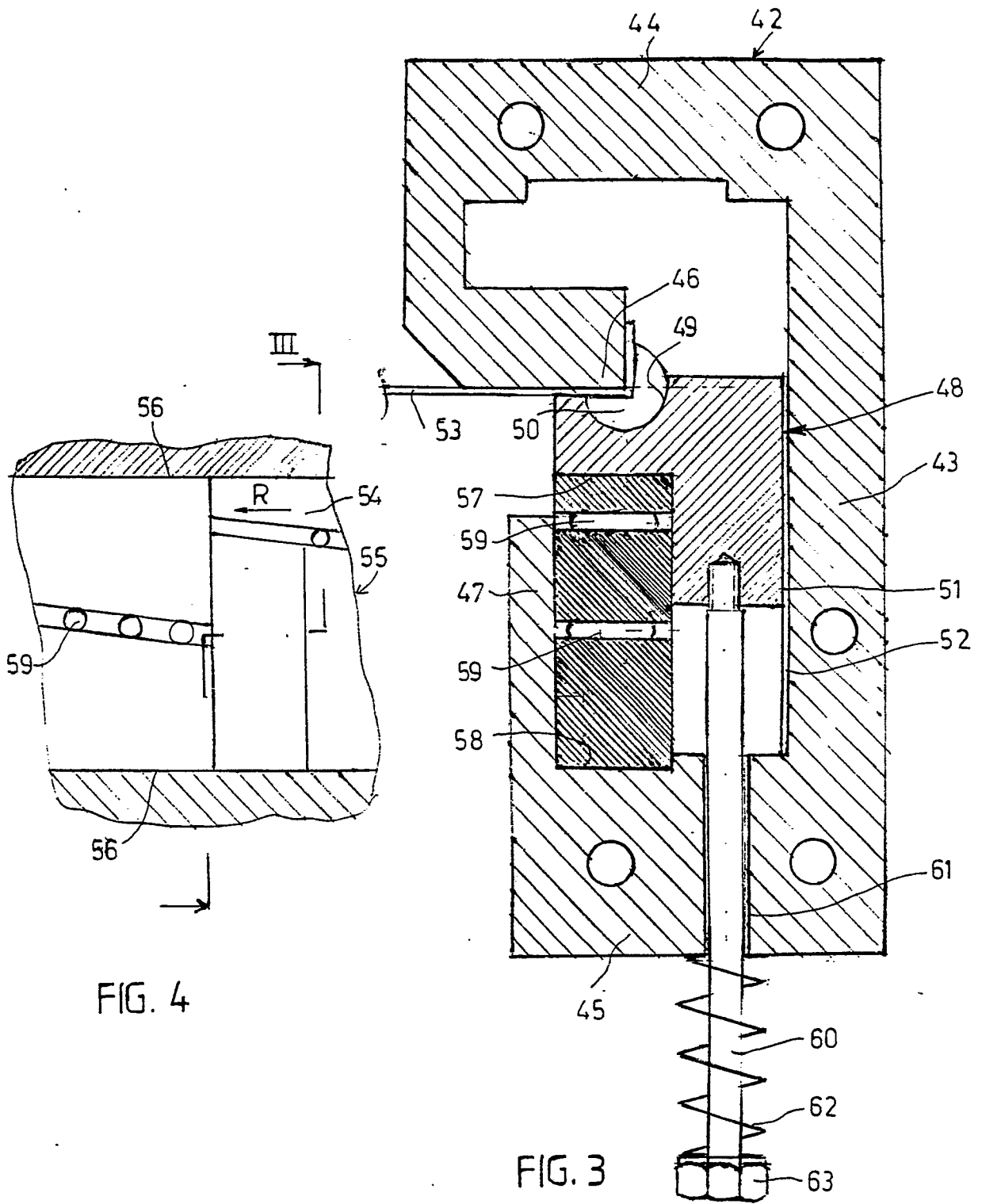

FIG. 4

FIG. 3





DOCUMENTS CONSIDERED TO BE RELEVANT			
Category	Citation of document with indication, where appropriate, of relevant passages	Relevant to claim	CLASSIFICATION OF THE APPLICATION (Int. Cl.5)
A	GB-A-2 004 216 (SALVAGNINI) * Page 2, lines 23-32; figures 1,2 * ---	1-7	B 21 D 19/08
A	US-A-3 400 568 (BRANDNER) * Fig. * ---	2,3	
A	GB-A- 301 779 (HUMPHRIS) * Figures 10,11 * ---	8-10	
D,A	US-A-4 002 049 (RANDOLPH) ---		
A	FR-A-2 252 145 (PROTOCOL) ---		
A	FR-A-2 365 383 (ECKOLD) -----		
			TECHNICAL FIELDS SEARCHED (Int. Cl.5)
			B 21 D
The present search report has been drawn up for all claims			
Place of search THE HAGUE		Date of completion of the search 24-01-1990	Examiner SCHOOF S G.G.
<b>CATEGORY OF CITED DOCUMENTS</b> X : particularly relevant if taken alone Y : particularly relevant if combined with another document of the same category A : technological background O : non-written disclosure P : intermediate document		T : theory or principle underlying the invention E : earlier patent document, but published on, or after the filing date D : document cited in the application L : document cited for other reasons ..... & : member of the same patent family, corresponding document	