

**EUROPEAN PATENT APPLICATION**

Application number: **88500126.3**

Int. Cl.<sup>5</sup>: **B65D 83/20, B65D 83/28, A47L 23/05**

Date of filing: **22.12.88**

The title of the invention has been amended (Guidelines for Examination in the EPO, A-III, 7.3).

Applicant: **ARTEBEL, S.A.**  
**Calle Maldonado, 4-Bajo B**  
**E-28006 Madrid(ES)**

Date of publication of application: **27.06.90 Bulletin 90/26**

Inventor: **Vega Garcia, Mercedes**  
**c/Maldonado 4, Bajo B**  
**E-28006 Madrid(ES)**

Designated Contracting States:  
**DE ES FR GB IT**

**Actuator for a liquid-applicator.**

Actuator-Liquid Applicator to be attached to containers closed with metering pumps or aerosol valves, for spreading a liquid in a uniform manner over a surface by means of a piece of sponge material, in such a way that the saturation of the latter can be controlled by the user.

It comprises an actuator which fits at the same time the stem (10) of a pump or valve (13) and the neck (15) of the container and pump assembly to which it is attached. This actuator moves in its entirety to actuate the pump or valve of the container, directing the discharge of liquid vertically towards a sponge (7), which is covered by a closure cap (6).

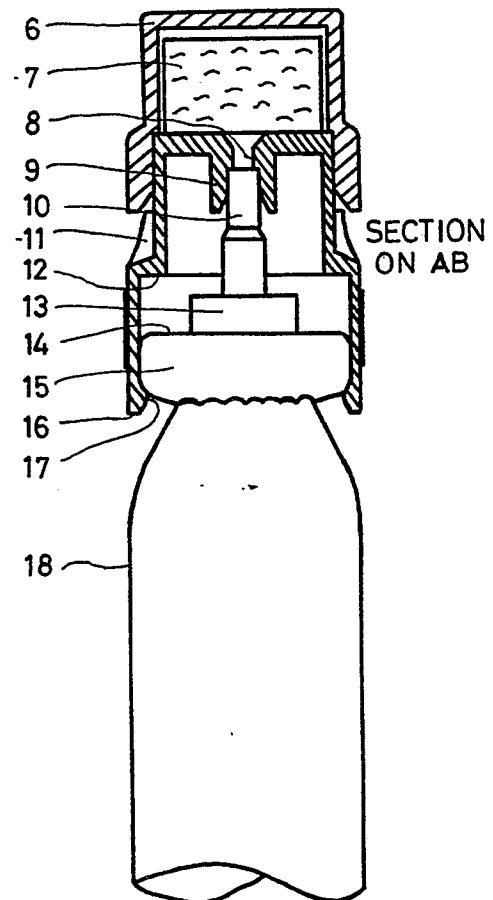

**FIG. 3**

**EP 0 374 339 A1**

### Actuator-Liquid Applicator

The invention relates to an Actuator-Liquid Applicator for attachment to containers with a metering pump or aerosol valve, permitting the uniform and adjustable application of a liquid to a surface by means of the sponge material attached to it.

Applicators with a sponge are used with liquids such as shoe polish and maintenance products and shoe dyes, whose use requires a uniform application of a liquid to a surface.

In the shoe polish market a sponge applicator is widely used, where the surface to which the sponge is attached has a skirt which fits inside the mouth of the liquid container, acting as a stopper. As a result the sponge applicator is fixed and does not move relative to the container. The liquid in the container reaches the sponge via an orifice in the surface to which the sponge is fixed. When not in use, this orifice is closed from inside the container by means of a small conical plug pushed by the spring contained in its base, forming a single unit. When closed the tip of the conical stopper protrudes through the orifice, and is concealed in the interior of the sponge. When the latter is pressed, the plug is pushed towards the interior of the container, overcoming the resistance of the spring and permitting outflow of the liquid.

In an applicator of this type the adjustment of the degree of saturation of the sponge by means of a conical stopper is very inexact since the flow of liquid towards the sponge is related in a non-linear way to the degree of movement of the stopper, and this is difficult for the user to control; especially due to the lack of visibility of the tip of the stopper, concealed in the interior of the sponge. This is likely to produce insufficient or excessive saturation of the sponge, of which the latter, apart from non-uniform application of the liquid, gives rise to leakage. In addition, the closure of the container by means of the stopper spring is insufficiently reliable over a period of time, since, being made of plastic material, it eventually becomes permanently deformed under compression, finally losing the strength required to produce a hermetic closure. The result is excessive saturation of the sponge, and leakage. An additional disadvantage is the impossibility of applying the needed pressure to the sponge during use, to remove any dirt attached to the surface to be cleaned without opening the orifice, which can give rise to leakage. This also applies to involuntary incremental pressure on the sponge.

The invention as claimed is intended to remedy these drawbacks. It solves the problem of how to spread a liquid evenly over a surface by means of a sponge attached in some way to the liquid

container, so that the degree of saturation of the sponge can be controlled by the user, with a sufficiently reliable control mechanism, thereby avoiding excessive saturation of the sponge and consequent leakage.

The advantages offered by the invention are mainly that the the sponge is saturated with the liquid only when the user wishes, pressing to this effect the Actuator-Liquid Applicator, with the container remaining completely closed at all other times. Saturation control is easily adjustable, with complete visibility of the distance travelled by the Actuator-Liquid Applicator. It also permits application of incremental pressure to the sponge, to remove any dirt attached to the surface to be cleaned, without risk of liquid leakage, as additional saturation can easily be prevented by the user. A further advantage of the invention is that not only the liquid container, but also the metering pump or valve, can be completely standard elements already on the market, with consequent high reliability. The use of containers with these pumps or valves for perfumery and pharmaceutical products is very common.

One way of carrying out the invention is described in detail below with reference to drawings which represent only one specific embodiment, in which:

Figure 1 is an elevation of an Actuator-Liquid Applicator in accordance with the invention. In this view the closure cap is not shown. Figure 2 is an overhead view of the Actuator-Liquid Applicator shown in figure 1. Figure 3 is a side view of a container with metering pump, where the Actuator-Liquid Applicator and its closure cap are shown sectioned on AB.

The figures show an Actuator-Liquid Applicator comprising an external cylinder (4), which has another cylinder of smaller diameter on top (2). The Actuator-Liquid Applicator is open at the bottom to permit it to be fitted to a container with metering pump or aerosol valve (15).

On the top a cylinder of sponge material (7) is fixed to a circular and flat surface (1), which has a hollow stem (9) underneath. This stem fits over the pump stem (10), thus permitting the liquid to reach the sponge on top, by pressing, and consequent longitudinal displacement of, the Actuator-Liquid Applicator towards the liquid container.

The Actuator-Liquid Applicator is closed by a cap (6) which fits vertically over the cylinder of lesser diameter (2). Its movement is limited by the horizontal surfaces (1 and 3). In Figure 3 this cap is shown in vertical section where it can be seen that the lower part has a larger diameter than the upper

part, and the same as the lower cylinder (4) of the Actuator-Liquid Applicator. The interior is slightly conical to facilitate fitting to the Actuator.

In accordance with the invention the lower surface of the Actuator (4) has two semicircular cut-outs (11), diametrically opposite each other. These cut-outs facilitate the placing of thumb and index finger during the displacement of the Actuator-Liquid Applicator towards the container, overcoming the compression resistance of the internal spring of the pump or valve. Below the cut-outs there are two slight protrusions in the form of an arrow (5) pointing downwards, whose function is simply an indication of the actuation method.

The Actuator-Liquid Applicator has two holes (19) diametrically opposite to each other and piercing surface (3). Their function is to permit the intercommunication of air between the internal chamber and the exterior, thus facilitating the movement of the Actuator over the neck (15) of the container with pump or valve.

In accordance with the preferred embodiment of the invention the Actuator-Liquid Applicator has, near the interior of its base, an annular protrusion (17) to avoid separation from the neck (15) of the container with pump or valve, and eliminate any unnecessary play.

In addition the hollow stem (9) is made slightly conical at the lower inside end to facilitate the entry of the pump stem (10) during assembly. The pump stem penetrates the hollow stem until it reaches a step of smaller diameter (8). The central orifice is also enlarged where it meets surface (1) to facilitate the saturation of the sponge by the liquid, and to avoid its blockage when the sponge is attached to it.

When the Actuator is pressed, it acts upon the pump or valve stem (10) which travels down until the internal step (12) seats on the top surface (14) of the pump or valve. The exterior of the container provides no obstacle to the bottom of the Actuator during the downward stroke.

## Claims

1. Actuator-Liquid Applicator for attachment to containers with a metering pump or aerosol valve, for the spreading of a liquid over a surface in a uniform and controllable manner, and comprising a piece of sponge material (7), covered by a closure cap (6) and fixed to the Actuator itself, which is attached to the pump or valve (13) fixed to the neck of a container (18). This Actuator is characterised by two superimposed cylinders (2,4). The upper cylinder is of smaller diameter than the lower one (4) and has on its top a flat circular surface (1) with a central orifice, prolonged downwards through

a hollow stem (9) which fits onto the stem (10) of the metering pump or aerosol valve of the container to which the Actuator is attached. The sponge (7), fixed to the flat circular surface (1), is covered by a closure cap (6) which, fitting closely the upper cylinder (2), is seated simultaneously on the two surfaces (1,3). The Actuator has an internal annular protrusion (17) in its lower base in order to prevent its separation from the neck (15) of the container with pump or valve. Surface (3) is pierced by two small air holes diametrically opposed to each other.

2. Actuator as claimed in claim 1, wherein the external cylinder (4) has two semicircular cut-outs (11) diametrically opposed to each other, below which there are two slight protrusions in the form of an arrow (5) pointing downwards.

3. Actuator as claimed in the previous claims, characterised in that the discharge of the pump or valve is directed vertically towards the sponge at the top.

4. Actuator as claimed in the previous claims, characterised in that the pump or valve to which it is fitted is hidden inside it, and cannot be seen.

5. Actuator as claimed in the previous claims, characterised in that it moves in its entirety when the pump or valve is operated.

6. Actuator as claimed in the previous claims, characterised in that the pumps or valves and containers used with the aforesaid actuator are freely available in the market and do not require any modification.

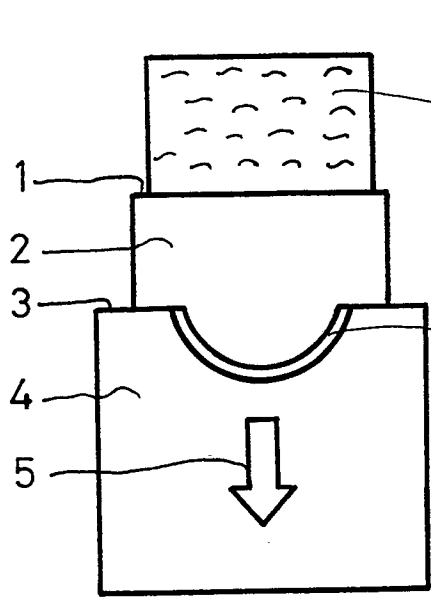

FIG. 1

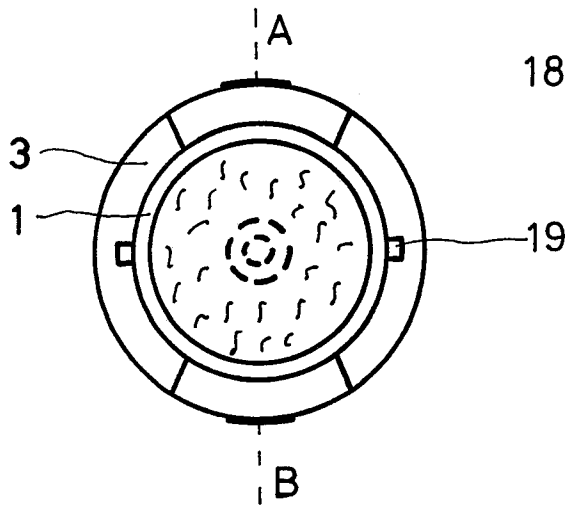

FIG. 2

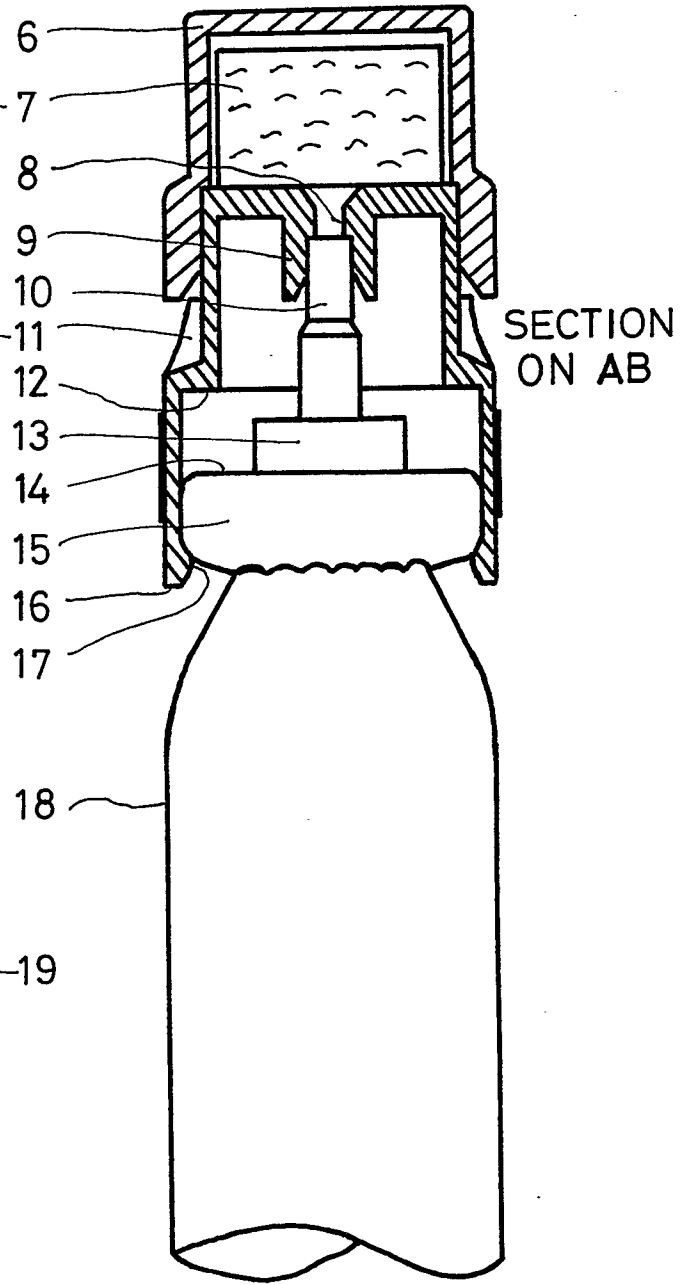

FIG. 3



DOCUMENTS CONSIDERED TO BE RELEVANT			
Category	Citation of document with indication, where appropriate, of relevant passages	Relevant to claim	CLASSIFICATION OF THE APPLICATION (Int. Cl.5)
X	CH-A- 466 176 (BAUMANN) * Column 2, line 36 - column 3, line 35; figures 1-4 *	1,3-5	B 65 D 83/20 B 65 D 83/28 A 47 L 23/05
A	----	2	
A	US-A-4 568 002 (WEINSTEIN) ----	2	
A	EP-A-0 127 453 (RECKITT AND COLMAN) * Figure 1 * -----	1	
			TECHNICAL FIELDS SEARCHED (Int. Cl.5)
			B 65 D A 47 L
The present search report has been drawn up for all claims			
Place of search THE HAGUE		Date of completion of the search 03-08-1989	Examiner NEWELL P. G.
<b>CATEGORY OF CITED DOCUMENTS</b> X : particularly relevant if taken alone Y : particularly relevant if combined with another document of the same category A : technological background O : non-written disclosure P : intermediate document T : theory or principle underlying the invention E : earlier patent document, but published on, or after the filing date D : document cited in the application L : document cited for other reasons ..... & : member of the same patent family, corresponding document			