

19



Europäisches Patentamt
European Patent Office
Office européen des brevets



11 Publication number:

0 384 096 B1

12

EUROPEAN PATENT SPECIFICATION

45 Date of publication of patent specification: **13.10.93** 51 Int. Cl.⁵: **E04B 7/10, E04B 1/32**

21 Application number: **89830068.6**

22 Date of filing: **21.02.89**

54 **Modular bearing structure, triangular in shape, for the construction of geodetic vaults.**

43 Date of publication of application:
29.08.90 Bulletin 90/35

45 Publication of the grant of the patent:
13.10.93 Bulletin 93/41

84 Designated Contracting States:
AT BE CH DE ES FR GB GR LI LU NL SE

56 References cited:
CH-A- 213 713 DE-A- 2 421 920
FR-A- 2 080 921 GB-A- 929 862
US-A- 3 255 556 US-A- 3 959 937
US-A- 4 009 543 US-A- 4 464 073
US-A- 4 542 759

73 Proprietor: **Sole, Pietro**
Via Ungaretti, 98
I-62100 Macerata(IT)

72 Inventor: **Sole, Pietro**
Via Ungaretti, 98
I-62100 Macerata(IT)

74 Representative: **Baldi, Claudio**
Piazza Ghislieri, 3
I-60035 Jesi (Ancona) (IT)

EP 0 384 096 B1

Note: Within nine months from the publication of the mention of the grant of the European patent, any person may give notice to the European Patent Office of opposition to the European patent granted. Notice of opposition shall be filed in a written reasoned statement. It shall not be deemed to have been filed until the opposition fee has been paid (Art. 99(1) European patent convention).

Description

This application relates to a triangular, supporting modular structure for constructing trellis geodetic vaults; be they cloister vaults; barrel vaults or spherical domes. There are many well known systems for constricting vault roofing but all, to a lesser or greater extent have the same problem of difficult assembly; often requiring costly scaffolds and reinforcements.

US Patent 4009543 describes a geodetic vault made by joining a large and a small triangular frame together, and having the features of the preamble of claim 1 or 3.

The three tubular bars of each frame have a flange and are connected by means of three "V" shaped couplings which make up the three vertices of the triangle.

Adjacent triangles are connected by means of bolts which fix the adjacent flanges of the adjacent bars.

Each side of the reticule of the geodetic vault consequently consists of a pair of adjacent, bolted tubular bars belonging to two different adjacent triangles.

The object of the US-A-4009543 disclosure was to design a triangular modular frame which could be connected to the adjacent frames at their vertices and not at the bars, for constricting geodetic vaults.

The object of the present invention is to design a new modular supporting structure for vault constructions being simple and inexpensive to construct, fast to assemble, easy to transport thanks to reduced sizes and weight, and being versatile, i.e. easy to adapt to the most varied requirements with the possibility of easily extending or reducing the same in the future.

The object of the invention is accomplished by the features of the characterising portions of claims 1 and 3.

In a preferred embodiment of the invention the above joint elements consist of thick box shaped sheet plate sleeves whose cross section has a "U" profile. The base of this "U" shape forms, which the two parallel and opposite sides, an angle equal to the half of the "alpha" angle corresponding to the angle at the centre of each circular section in which the geometric circle of the roofing vault is subdivided for the construction of trellis vaults.

Two half-sleeves as above are fitted at the two base vertices of the modular structure, the length of these being equal to half of the top sleeve which is obviously upside down with respect to the base half-sleeves, so that the ends of the two slanted bars can be filled and bolted into the parallel and opposite sides of the two sleeve and of the base half-sleeves, at the top and at the bottom respec-

tively.

A shelf is welded under the central side of the base half-sleeves, the same being turned towards the inside of the triangular frame and ending with a transverse tubular spacer which perfectly fits into the horizontal tubular bar of the modular structure in question. At the two ends of this bar there is a hole for the bolt which passes the above tubular spacer to fix both half-sleeves to the base bar.

At each node of the trelliswork formed by several modular structures according to the invention, and composed of top and base joint elements constructed according to the preferred embodiment as described above, two base half-sleeves being part of two adjacent modules, are positioned precisely over a top sleeve being part of a third module under the above adjacent modules.

At each node, each sleeve is fixed firmly to the two overlying half-sleeves by means of a pair of bolts which pass the matching and superimposed bases of the sleeve and half-sleeve.

According to another preferred embodiment of the top and base elements joining the bars of the modular structures, the same consist of a pair of gusset plates in which the ends of the bars are inserted and bolted.

The sizes and shape of the top pair of gusset plates, in which the two slanted bars of the triangular frame join, are obtained by positioning the two base pairs of half-gussets next to each other. The bottom edges of the half-gussets are bent around a horizontal axis to form an "alpha" angle equal to the angle at the centre of each circular section in which the geometric circle of the vault is divided for the construction of trellis "vaults".

The two top gusset plates are characterized by a double 90° horizontal bend of their upper edges, which are consequently parallel but closer with respect to their lower edges, so that at each node of the trelliswork realized using several modular structures as described above, a male and female type coupling occurs in such a way that the upper edges of each pair of top gusset plates exactly fits into the bent lower edges of two pairs of base half-gusset plates being part of two adjacent modules.

In this case the final fixing between the top and base joint elements can be made by means of a pair of bolts passed through the upper edges drawn closer together, of a pair of top gusset plates and through the bent lower edges of two pairs of base half-gusset plates.

For major clarity the description of the invention continues with reference to the enclosed drawing tables used descriptively rather than in a limiting sense, in which:

- fig. 1 illustrates the modular structure according to the invention, with joint elements constructed with sleeves and half-sleeves made

- of "U" box shaped sheet plate;
- fig. 2 illustrates a node of a trelliswork realized using several modular structures in the version illustrated in fig. 1;
- fig. 3 is the section of fig. 2 with the plane III-III of fig. 2;
- fig. 4 illustrates the modular structure according to the invention with top and base joint elements constructed with a pair of gusset plates and a pair of half-gusset plates, being suitably shaped and die-bent;
- fig. 5 illustrates a node of a trelliswork realized using several modular structures in the version illustrated in fig. 4;
- fig. 6 is the section of fig. 5 with the plane VI-VI of fig. 5;
- fig. 7 is a schematic representation of the break down of the geometric arch of a vault in circular sectors, with "alfa" angle at the centre, for the construction of trellis vaults;
- fig. 8 is a schematic representation of a section of trelliswork constructed using several modular structures according to the invention;
- figs. 9 and 10 illustrate two ridge joint elements constructed in the two above versions, one using "U" die-bent sheet plate sleeves, the other using a couple of gusset plates suitably shaped and die-bent.

With reference to figures 1, 2 and 3, the modular supporting structure according to the invention and according to its first preferred embodiment, consists of a frame having the shape of an isosceles triangle, formed by a tubular base bar (1) and by two slanted tubular bars (2) with holes (1a) and (2a) at their ends.

The two slanted bars (2) are connected by means of a joint sleeve (3), made of a "U" box metal element positioned upside down, into whose opposite sides the ends of the converging bars (2) are fitted; the converging bars (2) are fixed to the top sleeve (3) by means of bolts, which are not illustrated in the enclosed drawings, and which pass through holes (3a) made for this purpose on the sleeve (3) and through the holes (2a) of the bars (2), where an internal tubular spacer (2b) is welded as illustrated in section A-A of fig. 1.

Connection between the slanted bars and the horizontal base bar (1) is by means of two half-sleeves (4) each consisting of a metal box element having the same shape, but turned upside down with respect to that of the sleeve (3), having half the length of the latter.

The end of each bar (2) is fitted into the opposite sides of the box shaped element (4) where it is fixed firmly by means of bolts which pass through a hole (4a) made on the half-sleeves (4) and through the bushing (2b), welded in the bar (2) at the height of the above end holes (2a).

Connection between the bar (1) and the two side half-sleeves (4) is by means of a shelf (4b) welded on each half-sleeve (4) and ending with a transverse tubular spacer (4c) which perfectly fits into the bar (1) to allow the passage of the bolt which is fitted into the holes (1a) of the bar (1) so as to fix the latter to each half-sleeve (4).

With reference to figs. 3 and 7 attention is drawn to the fact that the base of the box elements (3) and (4) is slanted with respect to the horizontal direction of an angle equal to half the "alpha" angle at the centre of each circular section in which the geometric circle of the vault is divided, so that by positioning several modules on top of one another, the same are on differently slanted planes whose track forms a broken line coinciding with the spans of the circular sections in which the vault geometric circle is divided, as illustrated for purposes of clarification in fig. 7.

With reference to fig. 2, attention is drawn to the fact that the holes (3a) and (4a) of the base half-sleeves (3) and of the top sleeve (4) respectively are positioned so that by placing two half-sleeves (3) on top of a sleeve (4) the axes of the bars (2) cross at point N, through which the axis of the horizontal bars (1) also passes, forming the node, in which the longitudinal axes of the trelliswork bars, converge.

With reference to figures 4, 5 and 6, it can be noted how, according to a second preferred embodiment of the top and base elements joining the bars of the modular structure, these joint elements consist of pairs of gusset plates having suitable shape and sizes, in which the ends of the bars are bolted.

In particular, the pair of top gusset plates (30) in which the slanted bars (2) converge, is formed by two identical, adjacent metal plates, each of which has two holes (30a) through which two bolts - not illustrated in the drawing - pass and fix the two slanted bars (2) inside the pair of gusset plates (30) respectively.

The latter pair of top gusset plates are characterized in that they have a double bend of 90° along the upper edges of each plate between which there is a space less than the existing space between the lower edges of these plates in which the ends of the slanted bars (2) are fitted and bolted.

Each base element joining the slanted bars (2) and the horizontal bar (1) consists of a pair of half-gusset plates (40) composed of two identical adjacent metal plates, whose shape and sizes are half that of the plates forming the pair of top gusset plates (30).

There is a hole (40a) on the pair of base half-gusset plates (40) for the bolt - not illustrated in the drawing - which fixes the slanted bar (2) inside the

pair of half-gusset plates (40).

There is also a hole (40b) on the pair of half-gusset plates (40) for the bolt which fixes the end of the horizontal bar (1) in the pair of base half-gusset plates (40).

With reference to fig. 6 attention is drawn to the fact that the lower edges of this pair of base half-gusset plates (40) are bent around a horizontal axis by an "alpha" angle equal to the angle at the centre of each circular section in which the geometric circle of the vault is divided (see fig. 7) for the construction of the trellis vault.

The distance between the two plates forming the pair of base half-gusset plates (40) is such that the edges drawn closer together, of the pair of top gusset plates (30) can fit perfectly into the lower bent edges of said pair of base half-gusset plates (40) where these edges drawn closer together can be fixed firmly by means of a bolt passing through holes (40c) and (30c) on the edges drawn closer together of the base half-gusset plates (40) and on the lower bent edges of the top gusset plates (30) respectively.

With reference to fig. 9 attention is drawn to the fact that if the top sleeve is a ridge sleeve, i.e. a part of the module with which the trellis structure ends at the top, it has two side shelves (3b) terminating with a transverse spacer (3c) for connecting the horizontal bars (10) which join the top vertices of the adjacent modules with which the trellis structure ends at the top, as shown in fig 8.

With reference to fig. 10 attention is drawn to the fact that if the top gusset plate is a ridge gusset plate, it has two holes (30b) for the bolts connecting the horizontal bars (10) which join the top vertices of the adjacent modules with which the trellis structure ends at the top; in this case there is no double 90° bend of the upper edges of the gusset plates.

Claims

1. A triangular modular supporting structure for constructing geodetic vaults, consisting of a frame in the shape of an isosceles triangle at whose vertices three couplings are used to connect the three tubular bars characterized in that at the two base vertices the bars are connected by means of two semi-joint elements whose length and shape are half that of the top joint element used at the top vertex of the triangular frame; the joint elements and semi-joint elements comprise sleeves (3) and half-sleeves (4) respectively obtained by means of a "U" shaped metal channel section into the ends of which the converging equal length tubular bars (2) are fitted, being fixed to the top sleeves (3) and to the base half-

sleeves (4) by means of bolts fitted into holes (3a) and (4a) in the sleeves (3) and the half-sleeves (4) and into holes (2a) at the ends of the bars (2) where an internal tubular spacer (2b) is fitted to prevent deformation of the tubular bar when the respective bolts are tightened; the connection between the horizontal bar (1) and the two lateral base half-sleeves (4) is obtained by welding onto each half-sleeve (4), a flange (4b) having at one end a transverse tubular spacer (4c) which perfectly fits into the bar (1) and allows passage of the bolt which is fitted into the holes (1a) in the bar (1) through the tubular spacer so as to fix the base tubular bar to each half-sleeve (4).

2. A triangular, modular supporting structure for constructing geodetic vaults according to the previous claim characterized in that the base of the box elements (3) and (4) is slanted with respect to the horizontal direction of an angle equal to half of the "alpha" angle at the centre of each circular section in which the geometric circle of the vault is subdivided.
3. A triangular modular supporting structure for constructing geodetic vaults, consisting of a frame in the shape of an isosceles triangle at whose vertices three couplings are used to connect the three bars characterized in that at the two base vertices the bars are connected by means of two semi-joint elements whose length and shape are half that of the top joint element used at the top vertex of the triangular frame; the joint elements and semi-joint elements consist respectively of pairs of gusset plates (30) or semi-gusset plates (40) having suitable shape and sizes, between which the ends of the bars are bolted:
 - the pair of top gusset plates (30) into which the side bars (2) converge, consists of two identical and adjacent metal plates having a double 90° bend along the upper edges of each plate, between which there is a space smaller than the space between the lower edges of these plates, in which holes are provided (30a) for the bolts which fix the bars (2) in the pair of gusset plates (30);
 - the pair of base semi-gussets (4) consists of two identical and adjacent metal plates in which two holes (40a) and (40b) respectively are provided through which the bolt which fixes the side bars (2) and the bolt which fixes the base bar (1), pass.

4. A triangular, modular supporting structure for constructing geodetic vaults, according to claim 3, characterized in that the lower edges of the pair of base semi-gusset plates (40) are bent around a horizontal axis of an "alpha" angle equal to the angle at the centre of each circular section in which the vault geometric circle is subdivided for the construction of trellis vaults. 5
5. A triangular, modular supporting structure for constructing geodetic vaults according to claims 3 and 4, characterized in that the space between the two plates forming the pair of base gusset plates (40) is such that the edges drawn closer together, of the pair of top gusset plates (30) drawn closer together can be exactly fitted into the lower bent edges of said pair of base semi-gusset plates (40) where these edges drawn closer together can be firmly fixed by means of a transverse bolt, for which there are holes (40c) and (30c) on the edges drawn closer together, of the base semi-gusset plates (40) and on the lower bent edges of the top gusset plates (30) respectively. 10
15
20
25
6. A triangular, modular structure for constructing geodetic vaults according to claim 1 characterized in that, should the top sleeve be a ridge sleeve, this will have two side shelves (3b) ending with a transverse spacer (3c) for connecting the horizontal bars (10), joining the top vertices of the adjacent modules, with which the trellis structure ends at the top. 30
35
7. A triangular, modular supporting structure for constructing geodetic vaults according to claim 3, characterized in that, should the gusset plate be a ridge gusset plate, it will have two holes (30b) for the bolts which connect the horizontal bars (10) joining the top vertices of the adjacent modules with which the trellis structure ends at the top, in that the double 90° bend is no longer made along the upper edges of the gusset plates. 40
45

Patentansprüche

1. Modulare, dreieckige Tragstruktur für den Bau von geodätischen Gewölben, bestehend aus einem Rahmen in der Form eines gleichschenkligen Dreiecks, an dessen Scheiteln drei Gelenke zur Verbindung der drei Rohrstangen verwendet werden, modulare Struktur, dadurch gekennzeichnet, daß an den zwei Basis-Scheiteln die Stangen durch zwei Verbindungshalbsockel verbunden werden, dessen Längen und Formen gegenüber dem Kopfsockel halbiert 50
55

sind, der an dem Kopfscheitel des dreieckigen Rahmens verwendet wird; die oben genannten Verbindungssockel und -halbsockel besitzen jeweils aus einem U-förmigen Metallkasten gewonnene Muffen (3) und Halbmuffen (4), wo die konvergenten Rohrstangenenden gleicher Länge (2) eingesetzt werden, Stangen, die an der Kopfmuffe (3) und an den Basis-Halbmuffen (4) durch Bolzen befestigt werden, die durch die zu diesem Zweck an der Muffe (3) und Halbmuffen (4) vorgesehenen Löchern (3a) und (4a) eingeschraubt werden sowie in die zu diesem Zweck am Stangenende (2) vorgesehenen Löcher (2a), an denen ferner ein rohrförmiges internes Distanzstück (2b) vorgesehen ist, das Verformungen der Rohrschiene während des Anzugs der oben genannten Befestigungsbolzen verhindert; die Verbindung der horizontalen Stange (1) mit den beiden seitlichen Basismuffen (4) erfolgt durch Aufschweißen einer Platte (4b) auf jede Halbmuffe (4), die an ihrem einen Ende mit einem rohrförmigen Quer-Distanzstück (4c) endet, das genau in die Stange (1) eingesetzt ist und von dem in die Löcher (1a) der Stange (1) und durch das rohrförmige Distanzstück eingesetzten Bolzen durchlaufen wird, um die rohrförmige Basisstange an jeder Halbmuffe zu befestigen (4).

2. Modulare, dreieckige Tragstruktur für den Bau von geodätischen Gewölben, nach vorgenanntem Anspruch, dadurch gekennzeichnet, daß die Basis des Kastens (3) und (4) gegenüber einer horizontalen Richtung eine Winkels geneigt ist, der der Hälfte des Winkels "Alpha" im Zentrum eines jeden Kreisabschnitts, in den der geometrische Kreis des Gewölbes unterteilt wird entspricht.

3. Modulare, dreieckige Tragstruktur für den Bau von geodätischen Gewölben, bestehend aus einem Rahmen in der Form eines gleichschenkligen Dreiecks, an dessen Scheiteln drei Gelenke zur Verbindung der drei Stangen verwendet werden, modulare Struktur, dadurch gekennzeichnet, daß an den zwei Basis-Scheiteln die Stangen durch Verbindungshalbsockel verbunden werden, deren Länge und Form gegenüber dem Kopfsockel halbiert sind, der an dem Kopfscheitel des dreieckigen Rahmens verwendet wird; die vorgenannten Verbindungssockel- und halbsockel bestehen jeweils aus Eckplattenpaare (30) oder Halbeckplatten (40) geeigneter Form und Abmessung, in die die Stangenenden verschraubt werden:
- das Kopfeckplattenpaar (30), in das die seitlichen Stangen (2) konvergieren, ist

- aus zwei identischen und Seite an Seite stehenden Metallplatten gebildet, die eine doppelte 90°-Biegung an den oberen Rändern einer jeden Platte aufweisen, zwischen denen eine Entfernung besteht, die kleiner als die zwischen den unteren Rändern der genannten Platten ist, in die Löcher (30a) für die Befestigungsbolzen der Stangen (2) in das Eckplattenpaar (30) vorgesehen sind;
- das Basis-Halbeckplattenpaar (40) wird aus zwei identischen, Seite an Seite stehenden Metallplatten gebildet, auf denen zwei Löcher (40a) und (40b) jeweils für den Durchgang des Bolzens, der die seitliche Stange (2) befestigt sowie für den Bolzen der die Basisstange (1) befestigt, vorgesehen sind.
4. Modulare, dreieckige Tragstruktur für den Bau von geodätischen Gewölben, nach Anspruch 3, gekennzeichnet dadurch, daß die unteren Ränder des Halbeckplattenpaars (40) um eine horizontale Achse eines Winkels "Alpha" gebogen sind, der ebensogroß ist wie der Winkel in der Mitte eines jeden Kreisabschnitts, in den der geometrische Kreis des Gewölbes für den Bau von gitterartigen Gewölbeabdeckungen unterteilt ist.
5. Modulare, dreieckige Tragstruktur für den Bau von geodätischen Gewölben, nach Anspruch 3 und 4, dadurch gekennzeichnet, daß die Entfernung zwischen den zwei Platten, die das Basis-Eckplattenpaar (40) bilden, so bemessen ist, daß die angenäherten Ränder des Kopfeckenplattenpaars (30) genau bis zum Anschlag in die gebogenen unteren Ränder des genannten Basis-Halbeckplattenpaars (40) passen, wo die genannten angenäherten Ränder endgültig mittels eines Querbolzens befestigt werden können, für dessen Durchgang Löcher (40c) und (30c) jeweils auf den angenäherten Rändern der Basis-Halbeckplatten (40) und auf den unteren gebogenen Rändern der Kopfeckenplatten (30) vorgesehen sind.
6. Modulare, dreieckige Tragstruktur für den Bau von geodätischen Gewölben, nach Anspruch (1), dadurch gekennzeichnet, daß, falls die Kopfmuffe eine First-Muffe ist, sie zwei seitliche Plättchen (3b) aufweist, die mit einem Quer-Distanzstück (3c) zur Verbindung der horizontalen Stangen (10) enden, die die Kopfscheitel der Seite an Seite stehenden Module, mit denen die gitterartige Struktur oben endet, verbinden.

7. Modulare, dreieckige Tragstruktur für den Bau von geodätischen Gewölben, nach Anspruch 3), dadurch gekennzeichnet, daß, falls die Kopfeckenplatte eine First-Platte ist, sie zwei Löcher (30b) aufweist, an denen die Bolzen, die die horizontalen Stangen (10) verbinden, eingesetzt werden, Stangen die die Kopfscheitel der Seite an Seite stehenden Module verbinden, mit denen oben die gitterartige Struktur endet, da die doppelte 90°-Biegung der oberen Ränder der Eckplatten nicht mehr vorgesehen ist.

Revendications

1. Structure portante à modules, triangulaire, pour la construction de voûtes géodésiques, qui consiste en un châssis en forme de triangle isocèle sur les sommets duquel on utilise trois joints pour le raccordement des trois tiges tubulaires, structure à modules, caractérisée en ce que sur les deux sommets de base les tiges sont reliées au moyen de deux semi-socles de jonction ayant tant la longueur que leur forme réduite de moitié par rapport au socle de tête qui est utilisé en correspondance du sommet de tête du châssis triangulaire; les susdits socles et semi-socles englobent respectivement des fourreaux (3) et des semi-fourreaux (4) réalisés en barre métallique pliée en forme de "U" où viennent exactement s'insérer les extrémités des tiges tubulaires ayant la même longueur, convergentes (2), lesdites tiges étant fixées au fourreau de tête (3) et aux semi-fourreaux de base (4) au moyen de boulons enfilés dans les perçages (3a) et (4a) prévus à cet effet sur le fourreau (3) et sur les semi-fourreaux (4) et dans les perçages (2a), prévus à cet effet sur l'extrémité des tiges (2) en correspondance desquels on a aussi prévu une entretoise interne tubulaire (2b) apte à empêcher les déformations de la barre tubulaire pendant le serrage des respectifs et susdits boulons de fixation; le raccordement de la tige horizontale (1) aux deux semi-fourreaux latéraux de base (4) s'effectue en soudant sur chaque semi-fourreau (4) un rebord (4b) terminé, à l'une de ses extrémités, au moyen d'une entretoise tubulaire transversale (4c) qui est parfaitement insérée dans la tige (1) et traversée par le boulon qui est enfilé dans les perçages (1a) de la tige (1) et à travers l'entretoise tubulaire pour fixer la tige tubulaire de base sur chaque fourreau (4).
2. Structure portante à modules, triangulaire, pour la construction de voûtes géodésiques, selon la revendication précédente, caractérisée en ce

- que la base des barres (3) et (4) résulte inclinée par rapport à une direction horizontale avec un angle égal à la moitié de l'angle "alfa" au centre de chaque secteur circulaire qui divise le cercle géométrique de la voûte.
3. Structure portante à modules, triangulaire, pour la construction de voûtes géodésiques, qui consiste en un châssis en forme de triangle isocèle sur les sommets duquel on utilise trois joints pour le raccordement des trois tiges, structure à modules, caractérisée en ce que sur les deux sommets de base les tiges sont reliées au moyen de deux semi-socles de jonction ayant tant la longueur que leur forme réduite de moitié par rapport au socle de tête qui est utilisé en correspondance du sommet de tête du châssis triangulaire; les susdits socles et semi-socles de jonction étant respectivement constitués d'une paire de plaques de raccordement (30) et de semi-plaques de raccordement (40), de forme et dimensions appropriées, et sur lesquelles sont boulonnées les extrémités des tiges.
- la paire de plaques de raccordement de tête (30), vers lesquelles convergent les tiges latérales (2), est formée de deux plaques métalliques identiques et juxtaposées, ayant un double pliage à 90° en proximité des bords supérieurs de chaque plaque qui ont une distance mineure de celle des bords inférieurs des lesdites plaques et dans lesquels sont prévus des perçages (30a) pour les boulons de fixation des tiges (2) dans la paire de plaques de raccordement (30);
 - la paire de semi-plaques de raccordement de tête (40) est formée de deux plaques métalliques identiques et juxtaposées sur lesquelles sont prévus respectivement deux perçages (40a) et (40b) pour le passage du boulon qui fixe la tige latérale (2) et pour le passage du boulon qui fixe la tige de base (1);
4. Structure portante à modules, triangulaire, pour la construction de voûtes géodésiques, selon la revendication 3), caractérisée en ce que les bords inférieurs de la paire de semi-plaques de raccordement de base (40) résultent pliés autour d'un axe horizontal d'un angle "alfa" égal à l'angle qui se trouve au centre de chaque secteur circulaire dans lequel on divise le cercle géométrique de la voûte pour la construction de couvertures réticulaires à voûte.
5. Structure portante à modules, triangulaire, pour la construction de voûtes géodésiques, selon les revendications 3) et 4), caractérisée en ce que la distance entre les deux plaques qui forment la paire de semi-plaques de raccordement de base (40) est telle que les bords rapprochés de la paire de plaques de raccordement de tête (30) peuvent exactement s'enfiler jusqu'au battement dans les bords inférieurs pliés de ladite paire de semi-plaques de raccordement de base (40); sur ce point lesdits bords rapprochés peuvent être définitivement fixés au moyen d'un boulon transversal pour lequel deux perçages (40c) et (30c) de passage sont respectivement prévus sur les bords rapprochés des semi-plaques de raccordement de base (40) et sur les bords inférieurs pliés des plaques de raccordement de tête (30).
6. Structure portante à modules, triangulaire, pour la construction de voûtes géodésiques, selon la revendication 1), caractérisée en ce que, si le fourreau de tête est un fourreau de crête, il présente deux rebords (3b) latéraux terminés par une entretoise transversale (3c) pour le raccordement des tiges horizontales (10) qui unissent les sommets de tête des modules juxtaposés qui terminent supérieurement la structure réticulaire.
7. Structure portante à modules, triangulaire, pour la construction de voûtes géodésiques, selon la revendication 3), caractérisée en ce que, si la plaque de raccordement de tête est une plaque de raccordement de crête, elle présente deux perçages (30b) en correspondance desquels enfiler les boulons qui relient les tiges horizontales (10) qui unissent les sommets de tête des modules juxtaposés qui terminent supérieurement la structure réticulaire vu que le double pliage de 90° des bords supérieurs des plaques de raccordement n'est plus prévu.

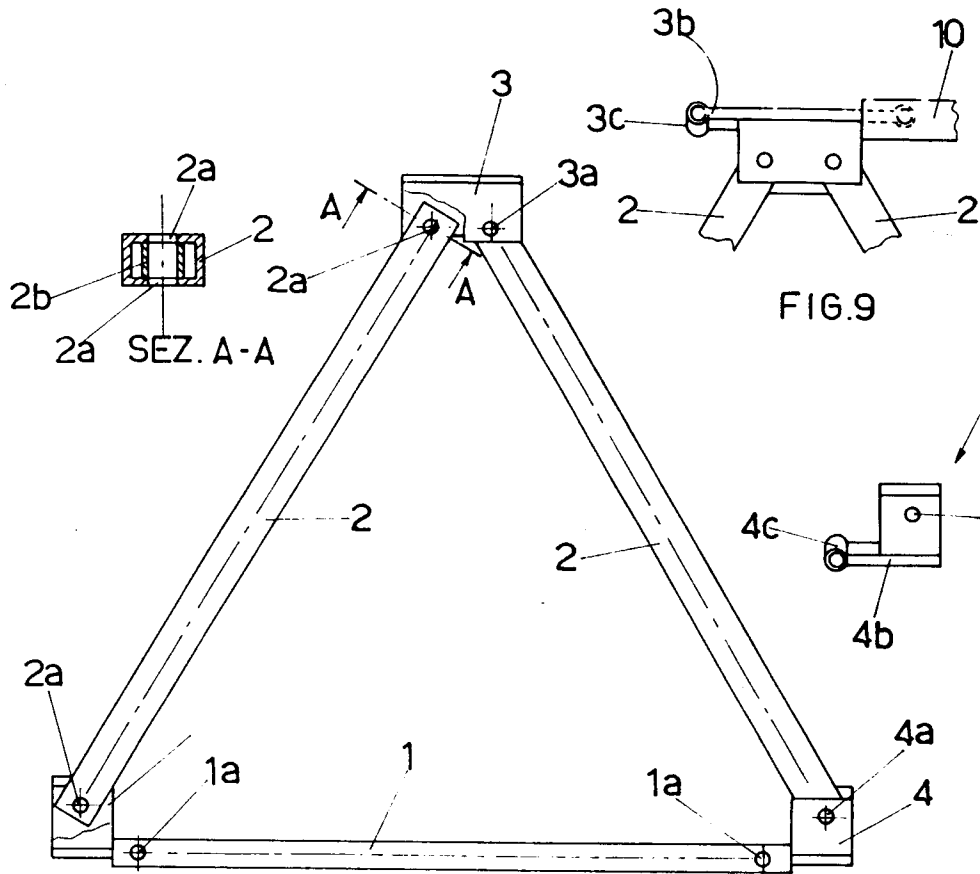

FIG. 1

FIG. 9

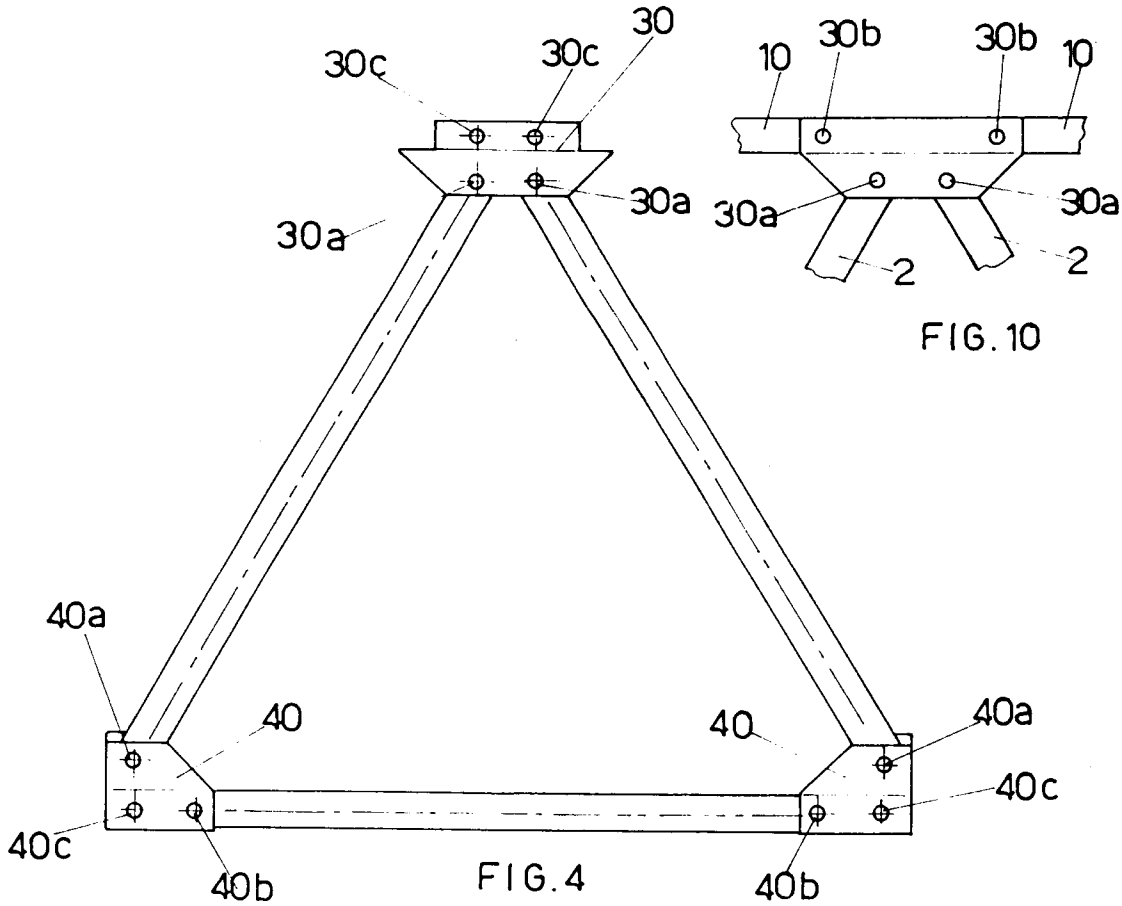
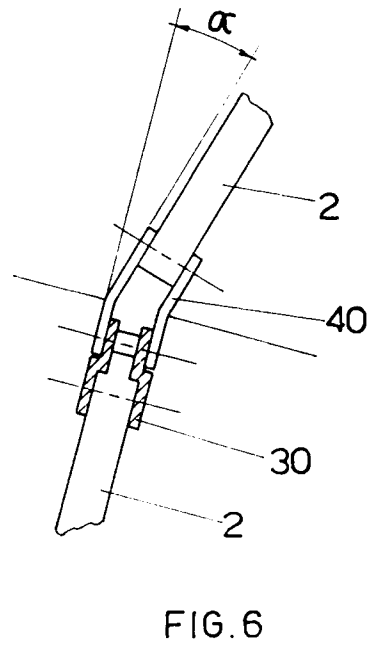
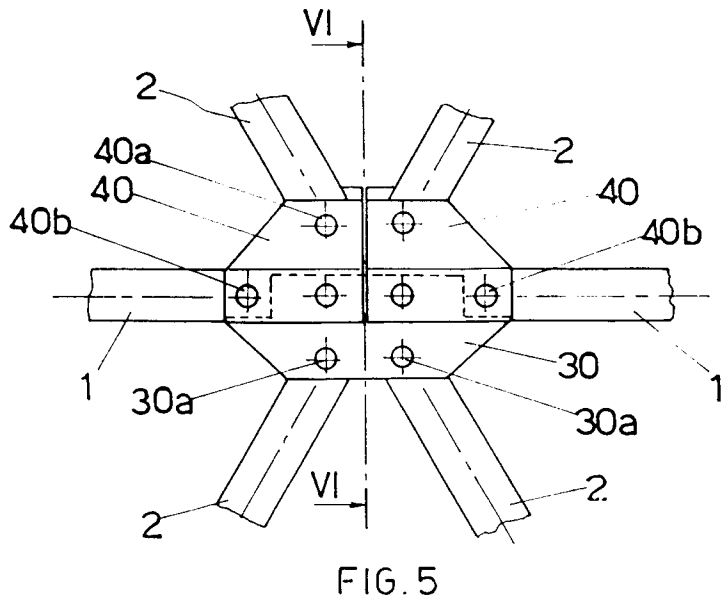
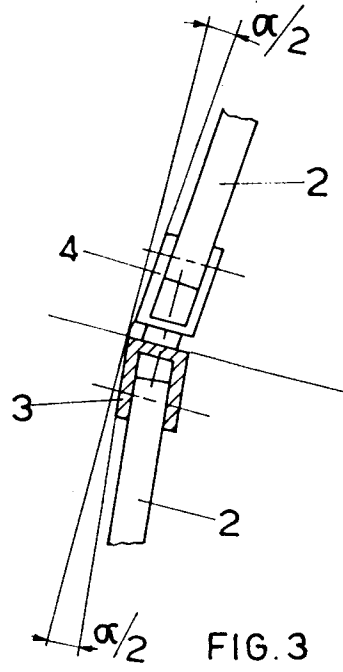
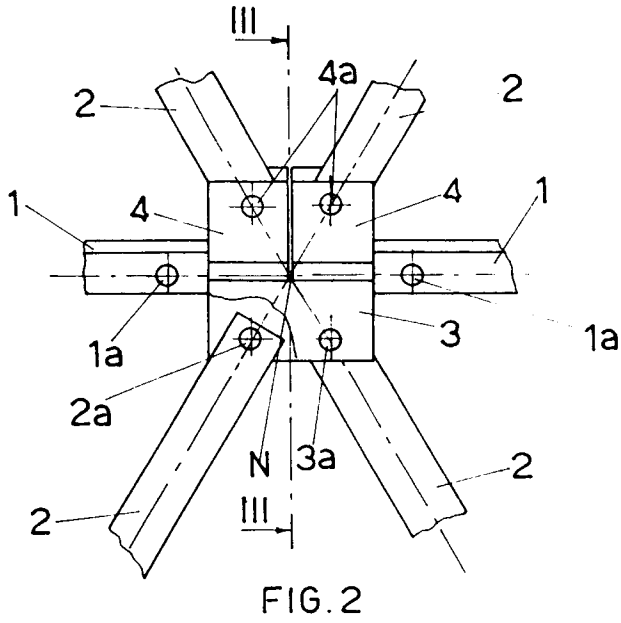

FIG. 4

FIG. 10



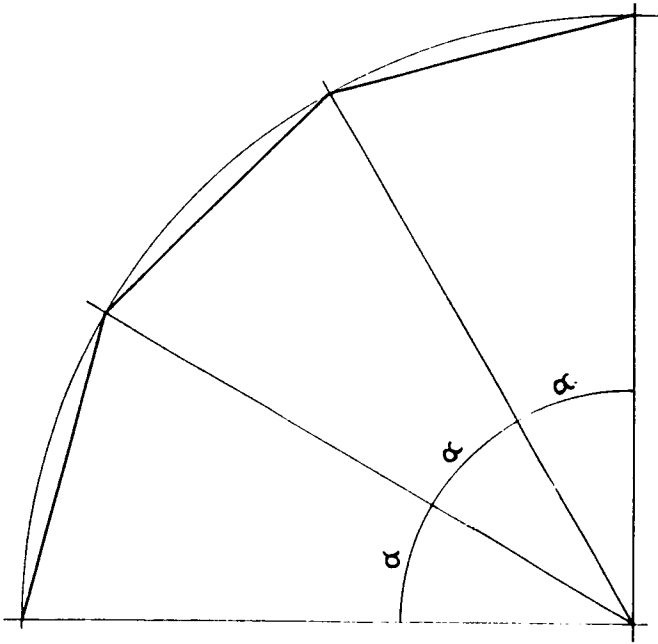

FIG.7

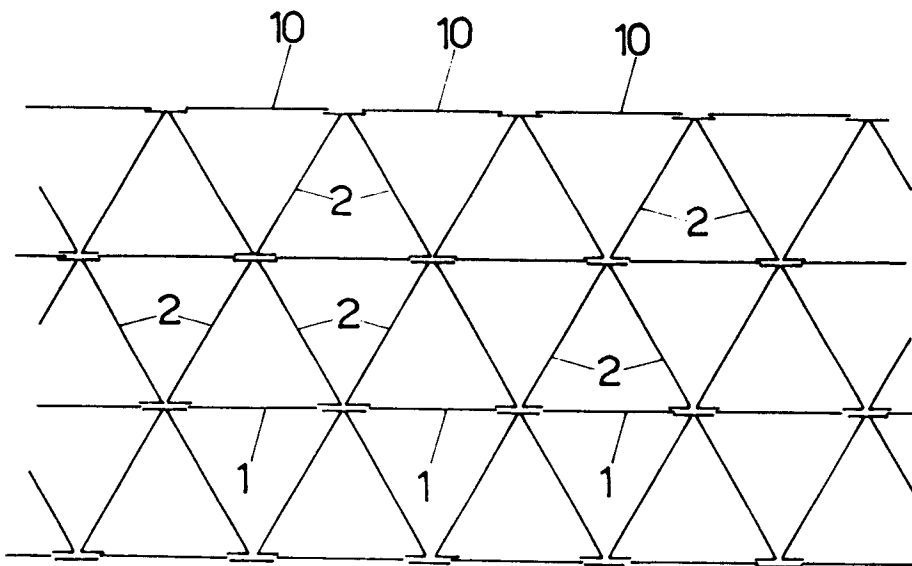

FIG.8