

(19)



Europäisches Patentamt

European Patent Office

Office européen des brevets



(11)

EP 0 390 412 B2

(12)

NEW EUROPEAN PATENT SPECIFICATION

(45) Date of publication and mention
of the opposition decision:
10.03.1999 Bulletin 1999/10

(51) Int. Cl.⁶: **B65D 41/34**

(45) Mention of the grant of the patent:
02.03.1994 Bulletin 1994/09

(21) Application number: **90303030.2**

(22) Date of filing: **21.03.1990**

(54) Tamper resistant closure cap for containers

Originalitätsverschluss für Behälter

Bouchon inviolable pour la fermeture de récipients

(84) Designated Contracting States:
BE CH DE DK FR GB LI NL SE

• **Stubbs, Peter**
Longfield, Kent (GB)

(30) Priority: **23.03.1989 GB 8906797**

(74) Representative:
Denmark, James et al
Bailey, Walsh & Co.
5 York Place
Leeds LS1 2SD Yorkshire (GB)

(43) Date of publication of application:
03.10.1990 Bulletin 1990/40

(73) Proprietor:
Johnsen & Jorgensen Plastics Limited
London SE8 5AB (GB)

(56) References cited:
EP-A- 213 742 **EP-A- 279 119**
EP-A- 0 200 293 **EP-B- 166 572**
DE-A- 3 224 002 **FR-A- 1 213 931**
US-A- 4 478 343 **US-A- 4 613 052**
US-A- 4 653 657 **US-A- 4 657 153**
US-A- 4 801 031

(72) Inventors:
• **Davis, Eugene Edward**
Barkingside, Ilford IG6 1AD (GB)

EP 0 390 412 B2

Description

[0001] This invention is concerned with the provision of a tamper resistant (TR) cap or tamper indicating cap made of plastics material and specially adapted for application to a container of standard form provided with a neck ring, as shown for example under reference number G.F.304 in a pamphlet issued by the Glass Manufacturers Federation.

[0002] Millions of such standard containers are made every year and such containers are at present closed by what is known in the trade as an ROPP (roll on pilfer proof) cap made of aluminium. ROPP caps are very satisfactory but aluminium is becoming increasingly expensive and a demand has been growing for the production of a tamper resistant cap of plastics material for these standard bottles. The main difficulty in the production of such a cap is that it is necessary for the cap to engage under the neck ring of the standard container. With the existing aluminium ROPP caps appropriate deformation of the metal is effective to shape the cap to engage under the neck ring and once deformed to the required shape the cap remains in its deformed condition. On the other hand plastics material after deformation does not normally hold its new shape unless it is positively held in position.

[0003] An attempt to solve this problem was made by Kerr Glass Manufacturing Corporation in their European Application published on 29.08.84 under No. 0117104 A2. In accordance with the Kerr Glass proposal a TR closure is provided which includes a threaded cap and TR means having upwardly and inwardly folded spaced apart tabs which lock against the lower surface of an annular shoulder formed by the neck ring on the container. A disadvantage of the Kerr Glass proposal is that it may be possible to remove the cap from the container without breaking the TR means by inserting an implement into the gaps between adjacent tabs.

[0004] Another proposal has been put forward by Owens-Illinois Inc in their European Patent Application published on 02.01.86 under No 0166572 A2. The Owens Illinois proposal also uses spaced apart tabs, which in that proposal are of wedge shape so that when there is an attempt to remove the closure the thicker portion of each tab wedges against the container wall to apply torque to the TR band which breaks the frangible means connecting the band to the skirt of the closure. Once again the gaps between adjacent tabs cause a problem.

[0005] In another proposal ACI Australia Ltd have tried to solve this problem in their European Patent Application No 0213742 A2 published on 11.03.87. In the ACI Australia proposal an annular flap is joined to the TR band of the cap but there may be a problem in the correct application of the cap to the container due to the presence of the flap which is completely annular and smooth in profile and so the cap may be difficult to apply

to a container.

[0006] Also, in US Patent 4,801,031 there has been proposed a closure having an extension skirt portion which is adapted to be tucked inwardly before application of the closure to the container neck and the inwardly turned skirt portion catches under the container neck ring to lock the closure in position, and providing a means preventing removal of the closure without featuring the closure. The application of the closure to the container in this case is inconvenient in requiring the skirt portion to be pre-tucked before application of the closure to the container.

[0007] It is an object of the present invention to provide an improved tamper resistant or tamper indicating cap of plastics material for a standard form of container with a neck ring which can be applied easily and without any modification to the container.

[0008] In accordance with the present invention there is provided a plastics material tamper resistant closure which is for application to a container having a mouth, a neck and a projecting ring in the neck, and which closure comprises a top, an annular wall depending from the top, said top and annular wall forming a cap portion, and a tamper resistant band connected by frangible means to the lower edge of the wall, and an annular container skirt connected to the lower edge of the tamper resistant band, which skirt is adapted to be tucked from a downwardly relaxed position inwardly of the closure to a locking position to engage the projecting neck ring on the container to prevent removal of the cap portion until the frangible means is broken, and wherein the said skirt in its downwardly relaxed position extends from the lower edge of the band in an inwardly tapering manner so that it is of smaller diameter at its lower edge than at its upper edge where it is connected to said band to facilitate said inward tucking of the skirt when the closure is applied to the container, characterised in that the skirt is expandable and contractible by being corrugated internally and externally.

[0009] Thus the skirt can expand as the closure is being applied to the container and can then contract again so that it is properly seated in operative position.

[0010] In order that the invention may be more clearly understood reference is now directed to the accompanying drawings, wherein:

Figure 1 is a side view of the upper part of a container of standard form according to reference GF 304; and

Figures 2 to 5 are various views of an embodiment of the invention.

[0011] Referring firstly to Figure 1 a container 1 has a mouth at the top 2, a screw thread 3 around the mouth and a neck ring 4 below the thread 3 shaped to provide a shoulder 5.

[0012] In Figures 2 to 5, a cap 6 has a top 7, a depending wall 8, a screw thread 9, and a TR band 10 con-

ned to the bottom edge of the wall 8 by frangible tongues 11. As described so far the cap 6 is of conventional construction, but in accordance with this invention the cap has an expandable or self-adjusting annular flip-over skirt 12 depending from the bottom of the band 10, in a tapered manner as shown, the skirt being internally corrugated at 13.

[0013] The cap 6 may be moulded in an injection moulding machine with the parts in the position shown in Figure 3, the cap may then be applied to the standard container 1.

[0014] If the container is intended to hold medicaments such as pills or medicines or other products which it is desired should not come into contact with plastics material, the cap may be provided with a wad or liner 15 as shown in Figure 2 so arranged that the wad or liner 15 seats on the rim around the mouth of the container and so seals the contents of the container from coming into contact with the plastics material of which the cap is made. As the cap is screwed on to the container, which is usually a glass bottle, the wad or liner 15 is compressed between the rim of the bottle and the inside of the cap so that a very effective seal is produced. If the wad or liner 15 is fitted as a means for providing a seal between bottle and cap, then the inversion of the self-adjusting annular flip-over skirt can take place during the insertion of the wad or liner 15, but in any case as the skirt is of tapered, conical form as shown the said inversion is facilitated. By this means, no further secondary operations are required to prepare the cap 6 for screwing onto the mouth of the container 1. Preferably the cap is made of Polypropylene or High Density Polyethylene.

[0015] The corrugations illustrated give the skirt 12 a sufficient degree of adjustability to enable the annular flap easily to pass over the neck ring 4 on the container 1.

[0016] In this specification by "a standard form of container" we mean a known form of container with a neck ring and substantially in accordance with Figure 1. By "a tamper resistant cap" we mean a cap that renders the assembly of cap and container resistant to tampering once the cap has been initially applied to the container because the cap cannot be removed without mutilating the cap which in turn gives evidence that the contents of the container may have been tampered with.

Claims

1. A plastics material tamper resistant closure which is for application to a container (1) having a mouth (2), a neck (3) and a projecting ring (4) in the neck (3), and which closure comprises a top, an annular wall (8) depending from the top, said top and annular wall (8) forming a cap portion, and a tamper resistant band (10) connected by frangible means (11) to the lower edge of the wall (8), and an annular container skirt connected to the lower edge of

the tamper resistant band (10), which skirt (12) is adapted to be tucked from a downwardly relaxed position inwardly of the closure to a locking position to engage the projecting neck ring (4) on the container (1) to prevent removal of the cap portion until the frangible means (11) is broken, and wherein the said skirt (12) in its downwardly relaxed position extends from the lower edge of the band (10) in an inwardly tapering manner so that it is of smaller diameter at its lower edge than at its upper edge where it is connected to said band (10) to facilitate said inward tucking of the skirt when the closure (6) is applied to the container (1), characterised in that the skirt is expandable and contractible by being corrugated internally (13) and externally (16).

Patentansprüche

1. Manipuliersicherer Verschluss aus Plastikmaterial zur Anwendung bei einem Behälter (1) mit einem Mundstück (2), einem Hals (3) und einem hervorstehenden Ring (4) am Hals, bei der der Verschluss einen Deckel und eine sich von dem Deckel erstreckende Ringwand (8) aufweist, wobei der Deckel und die Ringwand (8) einen Kappenteil bilden, und ein manipuliersicheres widerstandsband (10), das durch zerbrechliche Mittel (11) mit der unteren Kante der Wand (8) verbunden ist, und eine ringförmige Behälterschürze aufweist, die mit der unteren Kante des manipuliersicheren Bandes (10) verbunden ist, wobei die Schürze (12) in der Lage ist, von einer nach unten entspannten Position nach innen des Verschlusses in eine Verriegelungsposition gefalzt zu werden, um mit dem hervorstehenden Halsring (4) des Behälters (1) in Eingriff zu gelangen und ein Entfernen des Kappenteils solange zu verhindern, bis die zerbrechlichen Mittel (11) zerbrochen sind, und wobei die Schürze (12) in ihrer nach unten entspannten Position sich von der unteren Kante des Bandes in einer nach innen geneigten Weise erstreckt, so dass sie einen geringeren Durchmesser an ihrer unteren Kante als an ihrer oberen Kante aufweist, an der sie mit dem Band (10) verbunden ist, um die Falzung der Schürze nach innen zu erleichtern, wenn der Verschluss (6) dem Behälter (1) zugeführt wird, dadurch gekennzeichnet, dass die Schürze (12) innen und aussen gerippt (13) und dadurch dehnbar und kontrahierbar ist.

Revendications

1. Une fermeture résistante à touchage en matière plastique qui est pour application au bac (1) ayant une bouche (2), un goulot (3) et un anneau projetant (4) dans le goulot (3), et la fermeture comprend une tête, une paroi annulaire dépendant de la tête, ladite tête et la paroi (8) formant un couvercle et

une bande résistant à touchage (10) reliée par un moyen frangible (11) au bord inférieur du paroi (8), et une jupe (12) est adaptée d'être repliée, d'une position relâchée vers le bas, vers l'intérieur de la fermeture à une position de blocage pour s'engager l'anneau projetant du goulot (4) sur le bac (1) pour empêcher l'enlèvement du couvercle jusqu'au moyen frangible (11) est cassé, et en quoi ladite jupe (12) dans sa position relâchée vers le bas s'étend du bord inférieur de la bande (10) dans une façon effilante vers l'intérieur telle qu'elle est d'un diamètre plus petit à son bord inférieur qu'à son bord supérieur où elle est reliée à ladite bande (10) pour faciliter ledit répliage vers l'intérieur de la jupe quand la fermeture (6) est appliquée au bac (1), caractérisée en ce que la jupe est expansible et contractible en étant ondulée à l'intérieur et à l'extérieur.

5

10

15

20

25

30

35

40

45

50

55

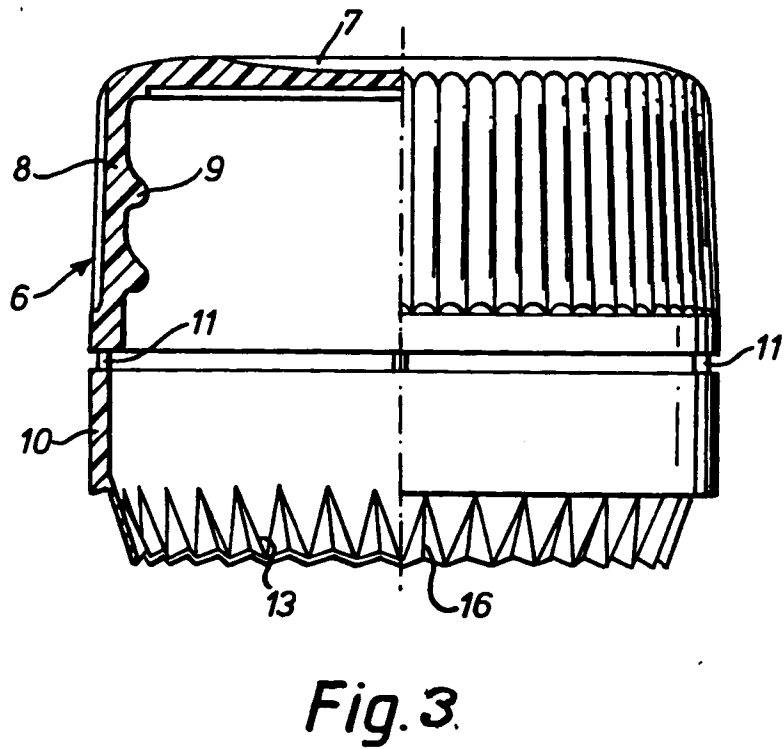
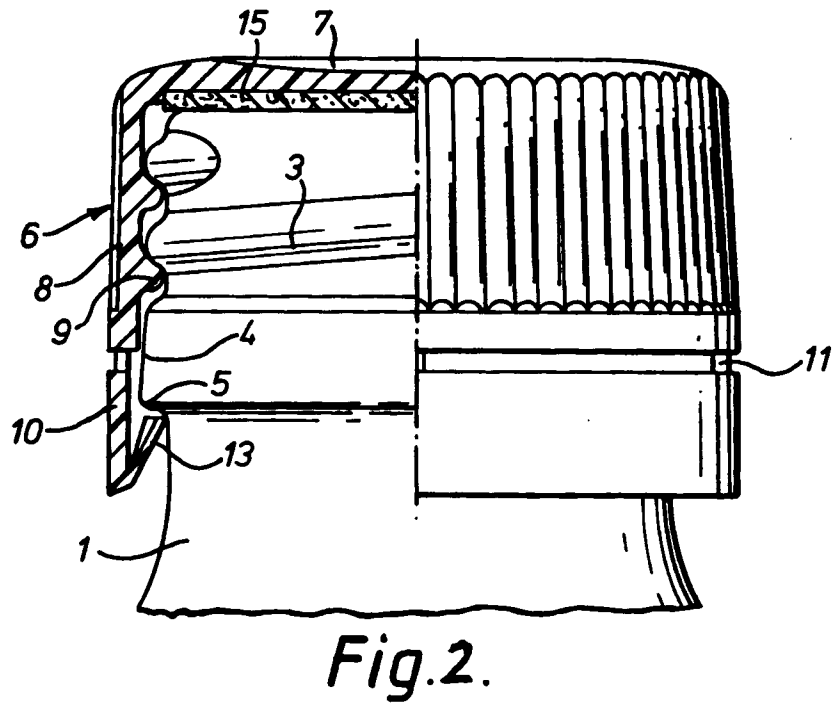
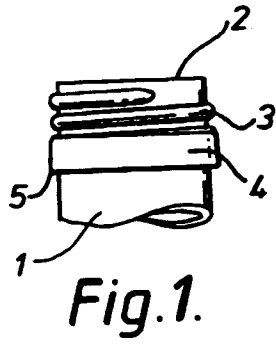

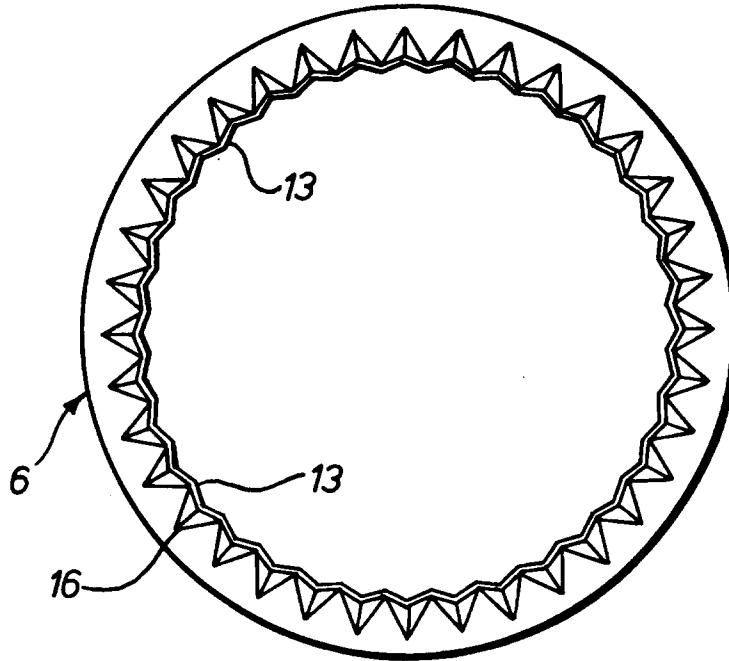

Fig. 4.

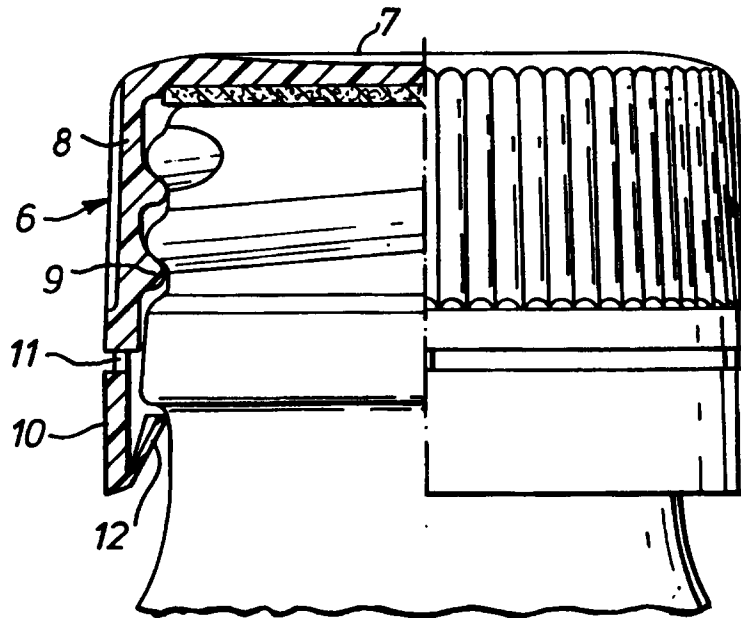

Fig. 5.