

EUROPEAN PATENT APPLICATION

Application number: **90302657.3**

Int. Cl.⁵: **B65H 43/00, B65H 29/40**

Date of filing: **13.03.90**

Priority: **31.03.89 GB 8907338**

Date of publication of application:
10.10.90 Bulletin 90/41

Designated Contracting States:
DE ES GB

Applicant: **DE LA RUE SYSTEMS LIMITED**
De la Rue House 3/5 Burlington Gardens
London W1A 1DL(GB)

Inventor: **Motion, William Cleghorn**
37, Hollow Lane
Hayling Island, Hampshire(GB)
Inventor: **Lloyd, Paul Douglas Vaughan**
2 Pennington Way
Fareham, Hampshire(GB)

Representative: **Skone James, Robert Edmund**
et al
GILL JENNINGS & EVERY 53-64 Chancery
Lane
London WC2A 1HN(GB)

Method and apparatus for feeding articles.

A method of feeding articles such as banknotes (11) into outwardly opening compartments (5) of a movable stacking device (1). The method comprises

- a) sensing (18) the passage of articles as they are fed to the stacking device (1);
- b) monitoring the movement of the device;
- c) determining whether the position of the article (11) which is sensed and the movement of the device (1) satisfy a predetermined condition in which the article will be successfully received in a compartment (5); and,
- d) if the condition is not satisfied, causing the device (1) to move at a different velocity for a fixed time (Δt) which is the same for each article so that the article is successfully received in a compartment (5).

Fig. 1.

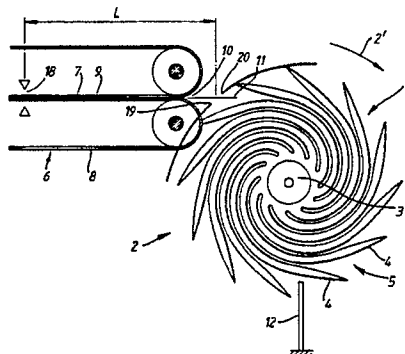

EP 0 391 550 A1

METHOD AND APPARATUS FOR FEEDING ARTICLES

The invention relates to methods and apparatus for feeding articles into outwardly opening compartments of a movable stacking device.

It is important in such apparatus to synchronise the feeding of articles with movement of the stacking device so that articles are cleanly fed into the compartments. If this is not done, then, particularly in the case of documents such as banknotes, the leading end of the article can engage a wall of the device and be deflected away from the compartment generating a so-called "flier".

Various attempts have been made in the past to deal with this problem. US-A-4244565 discloses the use of a pivoted regulating finger which can be moved into the path of an arriving article, such as a banknote, to impede its progress or can be moved away so as to remove that impedence, the degree of movement depending upon the time required to allow the rotating stacking wheel to be synchronised with the arrival of the sheet. This is a relatively complex system requiring the use of the regulating finger.

GB-A-2169103 discloses another method for synchronising the arrival of sheets at a stacking wheel in which the arrival of a leading edge of a sheet at a predetermined position upstream of the stacking wheel is detected and then the relationship between radially outwardly opening compartments of the stacking wheel and the arriving sheet is determined and if it is found that the sheet will not be synchronised with a compartment then the stacking wheel is caused to rotate at a second, higher angular velocity for a period which varies in accordance with the degree of non-synchronisation so as to bring the compartment into line with the arriving sheet. The main problem with this arrangement is that significant accelerations and decelerations may be required of the stacking wheel as it switches between its two predetermined speeds leading to severe disturbance of the wheel and the generation of vibrations in the tines defining the compartments. This leads to the need for a relative large distance between successive sheets in order to permit a recovery time for the stacking wheel.

WO83/00136 is similar to GB-A-2169103 in disclosing a synchronising system in which a fixed voltage is applied for a variable time to a drive motor. This results in wear which will degrade reliability.

In accordance with one aspect of the present invention, a method of feeding articles into outwardly opening compartments of a movable stacking device comprises

- a) sensing the passage of articles as they are fed to the stacking device;
- b) monitoring the movement of the device;
- c) determining whether the position of the article which is sensed and the movement of the device satisfy a predetermined condition in which the article will be successfully received in a compartment; and,
- d) if the condition is not satisfied, causing the device to move at a different velocity for a fixed time which is the same for each article so that the article is successfully received in a compartment.

In accordance with a second aspect of the present invention, article feeding apparatus comprises a movable stacking device having a number of outwardly opening, article receiving compartments; transport means for feeding articles to the stacking device; a sensor for sensing the passage of articles as they are fed by the transport means; a monitor for monitoring movement of the stacking device; and control means for determining whether the position of the article which is sensed by the sensor and the movement of the device as monitored by the device monitor satisfy a predetermined condition in which the article will be successfully received in a compartment of the device, and, if the condition is not satisfied, for causing the device to move at a different velocity for a fixed time which is the same for each article so that the article is successfully received in a compartment.

In contrast to the known synchronising arrangements, we have recognised that a much more efficient use of the apparatus can be achieved by fixing the time during which the velocity of the stacking device is changed from a normal, nominal velocity (step d) since this allows the magnitude of the velocity during that time to be optimised. For example, in the case of GB-A-2169103 and WO83/00136 (mentioned above) the stacking wheel is synchronised with the transport by switching the velocity to a second, higher velocity with a fixed magnitude for a period determined in accordance with the degree of non-synchronism. If the degree of non-synchronism is small then the stacker wheel would only be rotated at the higher velocity for a short time leading to high acceleration and deceleration being required. With the invention, however, the time period is fixed and the velocity varies in accordance with the degree of non-synchronism. Thus, in the case where there is only a small amount of non-synchronism, the change in velocity of the stacking device will be relatively small. This serves to minimise the rate of wear of the drive mechanism for the stacking device, the disturbance of the stacking device and, where the device comprises a stacker wheel with radially outwardly extending tines, vibrations in the tines. This avoids the need for a long recovery period leading to higher article feed rates being accommodated. Furthermore, calibration factors may be included to

overcome non-linear behaviour of the apparatus since the velocity applied is selectable.

Although the invention is primarily concerned with rotatable stacker wheels, it could also be applied to other stacking devices which operate in a cyclic manner such as an elongate belt having outwardly opening compartments. Preferably, however, in all cases the compartments are substantially equally spaced apart.

5 In general, the predetermined condition will be satisfied if an article will enter a compartment within a gap defined between the walls of the compartment and having ends spaced from the walls of the compartment. The exact dimensions of the gap will be determined empirically so as to minimise the risk of fliers occurring.

Typically, the stacking device will move at a substantially constant velocity, which may be fixed or
10 which may be linearly related to the article feed rate except during step d).

For example, in the case of a rotating stacking device, the device preferably normally rotates at a substantially constant angular velocity ω_0 (radians/sec) defined as:

$$\omega_0 = (2\pi/NT) \times NR \quad (1)$$

where NR is the article feed rate (articles/second) and NT is the number of compartments.

15 The fixed time during which the velocity is changed in step d) is preferably chosen to be less than the minimum article feed period and will generally be chosen to commence at a time when a known part, for example the centre, of a compartment is aligned with the point of entry of an article into the stacking device. If ω_1 is the calculated speed required to achieve synchronisation, and Δt is the fixed time period then this will result in a change of phase of the position of the stacking device relative to the time of sheet
20 arrival ($\Delta\theta$) defined by

$$\Delta\theta = (\omega_1 - \omega_0) \Delta t \quad (2)$$

In order to receive consecutive articles in consecutive compartments of the stacking device, it is necessary that

$$25 \Delta\theta = 2\pi/NT - \omega_0 ((NL + ING)/TS) \quad (3)$$

where

NL is the length of an article (for example in mm)

ING is the gap between successive articles (for example mm) and

TS is the article feed speed (for example mm/sec).

30 From equations (2) and (3), it is clear that

$$(\omega_1 - \omega_0) \Delta t = 2\pi/NT - \omega_0 ((NL + ING)/TS) \quad (4)$$

Equation (4) may be rewritten to define ω_1 , as

$$\omega_1 = [(2\pi/NT - \omega_0 (NL + ING)/TS)/\Delta t] + \omega_0 \quad (5)$$

The control means determines the current position of the stacking device while one or both or a
35 combination of the parameters NL and ING is monitored by the sensor.

Preferably, step (a) comprises sensing the arrival of each article at a predetermined position upstream of the stacking device so that the parameter NL + ING can be computed. Alternatively the interarticle gap ING could be determined alone by sensing the passage of a trailing edge and leading edge of successive articles past the predetermined position.

40 The mechanism will deal adequately with single articles, ie. articles which are not part of a steady stream, provided that the available range of ω_1 , and the distance L between a compartment and the position at which an article is sensed are suitably chosen.

If the maximum change in phase angle achievable in one Δt interval is equal to $\pm \frac{1}{2} \frac{2\pi}{NT}$, then it is clear that an article arriving totally asynchronous to the stacking device, or previous article stream, will be
45 accommodated provided sufficient warning of article arrival is given.

This means that:

$$L_{min} = TS \times (\Delta t + \text{device settling time}) \quad (6)$$

and

50

$$\omega_{1max} \geq \frac{\Delta\theta_{max}}{\Delta t} + \omega_0 \quad (7)$$

55

$$\omega_{1min} \leq \frac{\Delta\theta_{min}}{\Delta t} + \omega_0 \quad (8)$$

where L_{min} is the minimum permissible distance between the sensor and the point at which an article

enters the stacker.

The position of the sensor is not critical and for example could be positioned sufficiently upstream of the stacking device that more than one article can be present in the transport means between the sensor and the stacking device at one time.

5 Although in principle the transport (or article feed speed TS is constant and can be treated as a fixed parameter, in practice it is preferable to monitor the transport speed.

In addition, the average stacking device speed ω_0 can be treated as a fixed parameter or alternatively the article rate NR parameter can be monitored and used to adjust ω_0 as appropriate.

Of course ω_1 could be less than or greater than ω_0 .

10 An example of a method and apparatus for stacking banknotes will now be described with reference to the accompanying drawings, in which:-

Figure 1 is a schematic, partial view of the apparatus;

Figure 2 illustrates the control system;

Figure 3 illustrates graphically operation of the apparatus when synchronism exists; and,

15 Figure 4 illustrates graphically operation of the system when there is a degree of non-synchronism.

The apparatus shown in Figure 1 comprises a stacking device 1 which comprises a number of stacking wheels 2 mounted non-rotatably to a shaft 3 (one of the stacking wheels being shown in Figure 1). Each stacking wheel comprises a series of spiralling tines 4 between each pair of which is defined a note receiving compartment 5.

20 A note transport system 6 comprises a number of pairs of opposing belts 7, 8 which define a transport path 9 terminating adjacent to the stacking device 1 at a position 10. Banknotes are delivered into the transport system 6 in a conventional manner (not shown) and fed upon rotation of the belts 7, 8 along the transport path 9 to the exit 10. The stacking wheels 2 rotate in the direction of arrow 2' and are synchronised with note movement in the manner to be described so that as a banknote 11 exits from the transport 6 it enters between a pair of tines 4 into a compartment 5 of each stacking wheel 2. During this movement, the stacking device 1 is rotating in the clockwise direction 2', as seen in Figure 1, so that notes in each compartment are carried around until they engage a stripper plate 12 in a conventional manner which strips the notes from the compartments 5 to form a stack.

Figure 2 illustrates the control system for the apparatus shown in Figure 1. The shaft 3 is rotated by a motor 13 whose speed is controlled by a motor drive unit 14. The rotational position of the shaft 3 is determined from a sensor 15 which monitors the position of a slotted disc 16 non-rotatably mounted to the shaft 3. The sensor 15 outputs signals corresponding to the passage of each slot in the disc 16 to a controller 17. The controller 17 may be constituted in hardware, software (ie. a microcomputer) or a combination of the two and uses the information from the sensor 15 to generate a motor speed control signal which is fed to the motor drive unit 14. The controller 17 is also connected with a sensor 18 positioned, as shown in Figure 1, to detect the passage of banknotes along the transport path 9, the arrival of the leading edge of each banknote causing an appropriate signal to be fed to the controller 17. In addition, in this example, the feed speed of the transport means 6 is monitored (by means not shown) and fed to the controller 17.

40 In this example, each stacking wheel 2 has twelve tines 4 defining twelve compartments 5 so that the motion of the stacking device relative to the transport can be represented graphically as a cyclic motion extending through 30° . Thus, Figure 3 summarises the stable operating condition with the " 0° " position corresponding to the tip of a tine being in line with the leading edge of a note leaving the transport, the vertical scale representing the angular rotation of the stacking wheel, "modulo 30° ". The horizontal scale represents elapsed time. In Figure 3, a note period (NP) of 100 milliseconds has been assumed and the safe angular window or gap for the arrival of notes has been assumed to be from 9° ahead of the tine to 21° ahead of the tine ie. the note should arrive within 9° of any tine. This gap is illustrated in Figure 1 as defined between points 19, 20 on the peripheral locus of the tines. In Figure 3 the points 19, 20 are shown by horizontal lines at the 9° and 21° positions.

50 If the notes coming from the transport means 6 were perfectly timed then these notes would arrive, as shown in Figure 3, at 50ms, 150ms, 250ms, 350ms, etc. Under such conditions, the stacking wheel will rotate at a substantially constant angular velocity ω_0 although this could be trimmed by monitoring the note period itself.

Figure 4 is similar to Figure 3 but illustrates the case where a note is sensed by the sensor 18 as arriving earlier than expected. This is detected by the controller 17 which, while a downstream note is being successfully fed into the stacking device, monitors output signals from the sensor 18 so as to generate a value corresponding to the distance between the leading edge of the previous note passing the position of the sensor 18 (and now being fed to the stacking wheels 2) and the passage of the leading edge of the next

note. This value defines the term NL + ING referred to above from which the controller 17 computes the necessary correction angular velocity ω_1 in accordance the equation 3 above. Δt is preset at a suitable value which may be, for example, 60ms.

By monitoring output signals from the sensor 15, the controller 17 determines when the centre of the safe period is in line with the leading edge of the downstream note (position 21 in Figure 4) and at that instant the controller 17 instructs the motor drive unit 14 to increase the speed of the motor 13 to cause the shaft 3 to rotate at the angular velocity ω_1 . The controller allows the motor 13 to rotate at this higher angular velocity ω_1 for the period Δt and then instructs the motor drive unit 14 to cause the motor 13 to rotate the shaft 3 at the lower angular velocity ω_0 at time 22. As can be seen in Figure 4 the result of this higher speed of rotation is to change the phase of the stacking wheels 2 relative to the incoming note so that the new note, which arrives earlier than expected, will enter into a compartment 4 through the safe gap. Assuming that successive notes then arrive at expected intervals, the stacking wheels 2 will continue to rotate at the normal lower angular velocity ω_0 as shown in Figure 4.

In a similar manner, if a note is detected as arriving late then the shaft 3 will be rotated at a lower angular velocity to achieve synchronisation.

Claims

1. A method of feeding articles into outwardly opening compartments of a movable stacking device, the method comprising

- (a) sensing the passage of articles as they are fed to the stacking device;
- (b) monitoring the movement of the device;

(c) determining whether the position of the article which is sensed and the movement of the device satisfy a predetermined condition in which the article will be successfully received in a compartment; and,

(d) if the condition is not satisfied, causing the device to move at a different velocity for a fixed time which is the same for each article so that the article is successfully received in a compartment.

2. A method according to claim 1, wherein the predetermined condition is satisfied if an article will enter a compartment within a gap defined between the walls of the compartment and having ends spaced from the walls of the compartment.

3. A method according to claim 1 or claim 2, wherein the stacking device moves at a substantially constant velocity linearly related to the article feed rate except during step d.

4. A method according to claim 3, wherein a rotating stacking device is provided, the device normally rotating at a substantially constant angular velocity ω_0 (radians/sec) defined as:

$$\omega_0 = (2\pi/NT) \times NR$$

where NR is the article feed rate (articles/second) and NT is the number of compartments.

5. A method according to any of the preceding claims, wherein the fixed time during which the velocity is changed in step d is less than the minimum article feed period such that if ω_1 is the calculated speed required to achieve synchronisation, and Δt is the fixed time period then this will result in a change of phase of the position of the stacking device relative to the time of sheet arrival ($\Delta\theta$) defined by

$$\Delta\theta = (\omega_1 - \omega_0) \Delta t$$

where

NL is the length of an article (for example in mm)

ING is the gap between successive articles (for example mm) and

TS is the article feed speed (for example mm/sec).

6. Article feeding apparatus comprising a movable stacking device having a number of outwardly opening, article receiving compartments; transport means for feeding articles to the stacking device; a sensor for sensing the passage of articles as they are fed by the transport means; a monitor for monitoring movement of the stacking device; and control means for determining whether the position of the article which is sensed by the sensor and the movement of the device as monitored by the device monitor satisfy a predetermined condition in which the article will be successfully received in a compartment of the device, and, if the condition is not satisfied, for causing the device to move at a different velocity for a fixed time which is the same for each article so that the article is successfully received in a compartment.

7. Apparatus according to claim 6, in which the movable stacking device comprises a rotatable stacker wheel.

8. Apparatus according to claim 6 or claim 7 adapted to carry out a method according to any of claims 1 to 5.

Fig. 1.

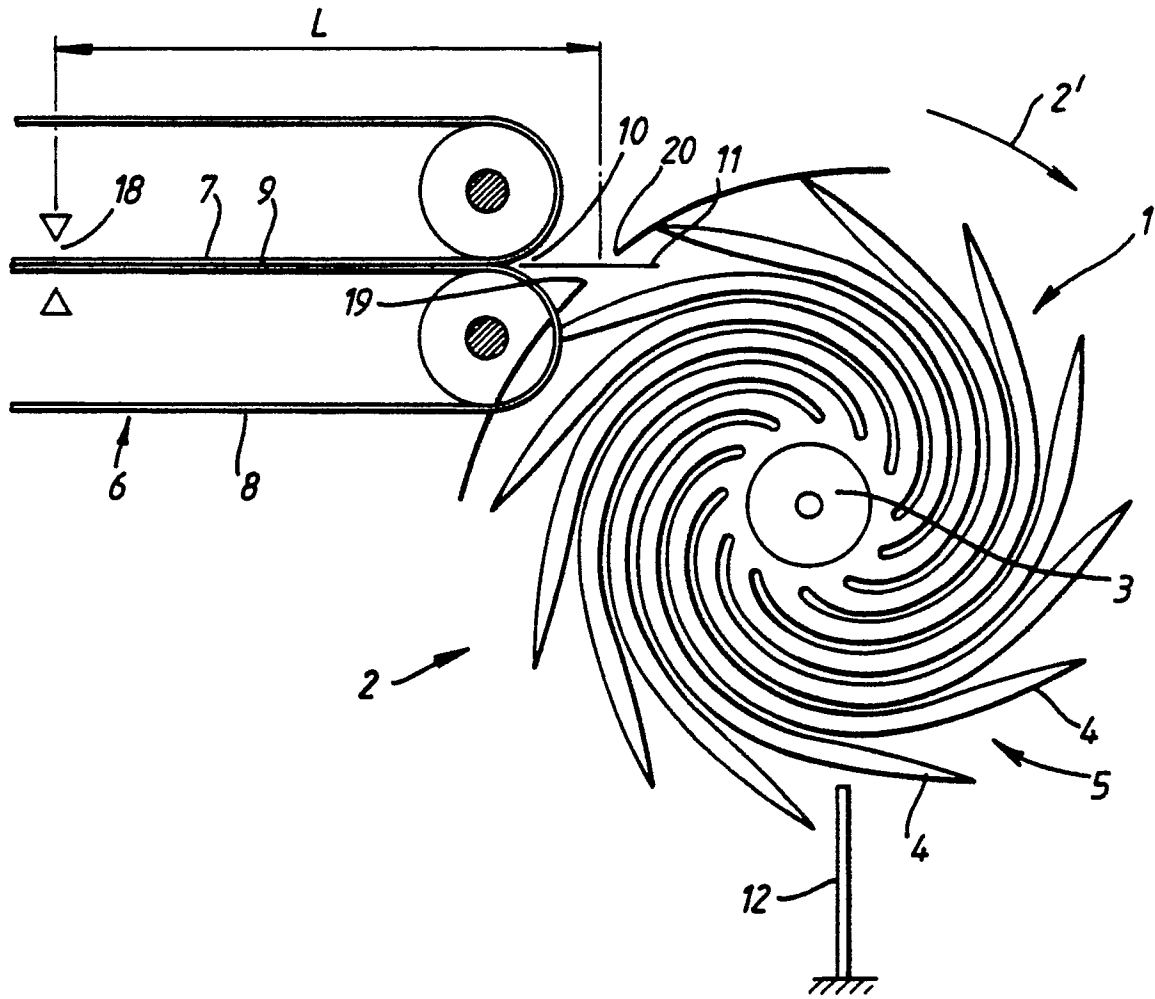

Fig. 2.

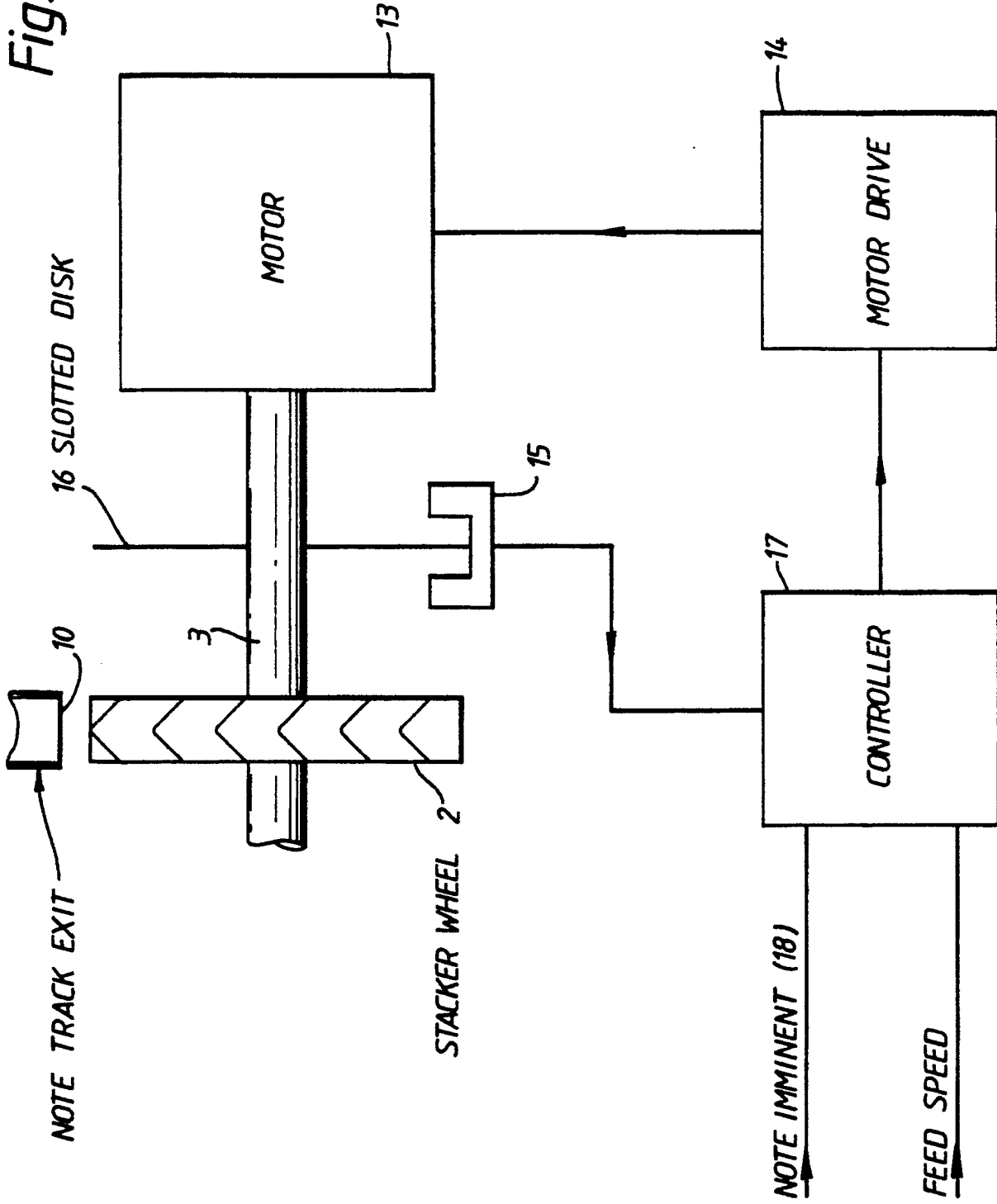

Fig. 3.

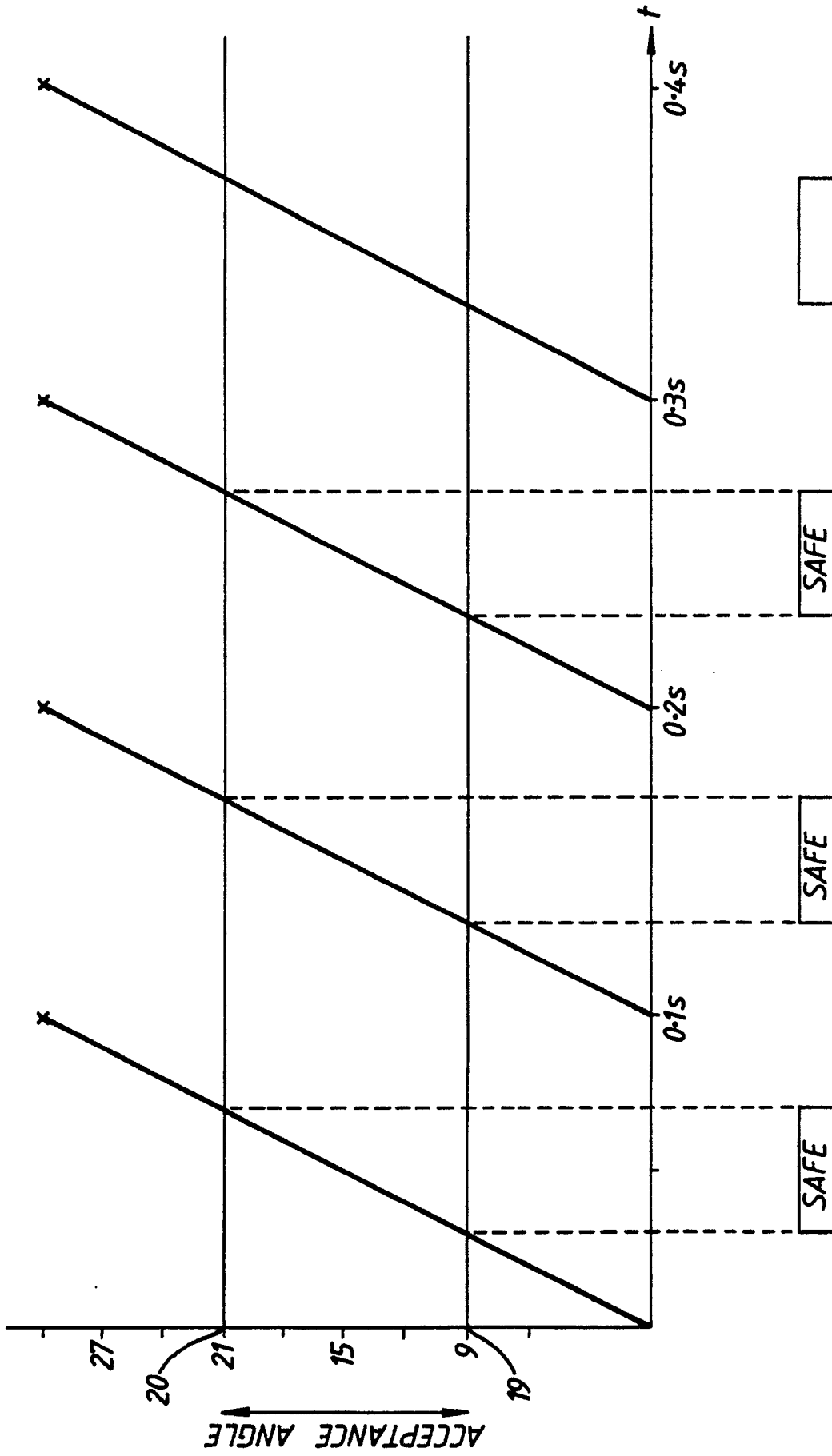
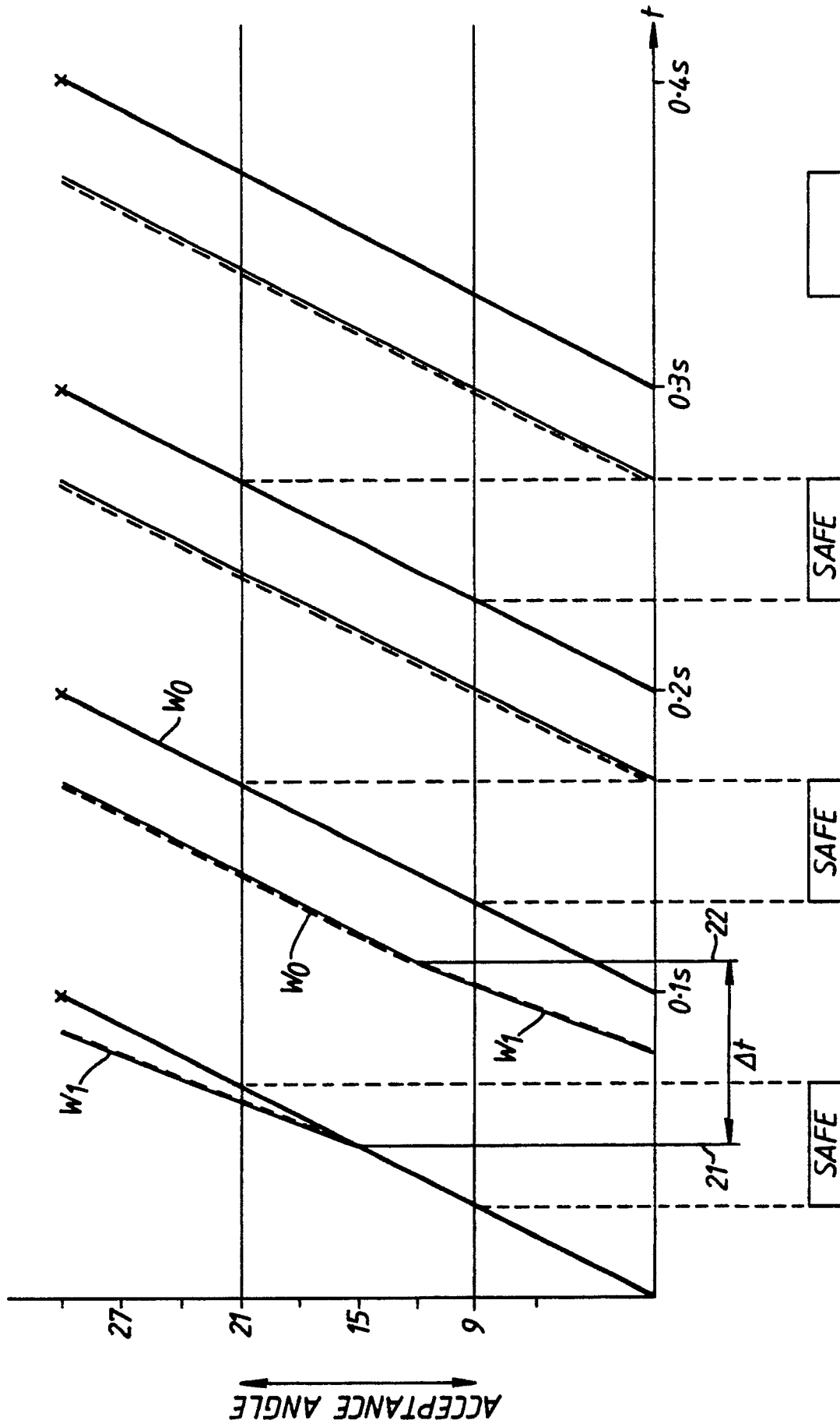

Fig. 4.





DOCUMENTS CONSIDERED TO BE RELEVANT			
Category	Citation of document with indication, where appropriate, of relevant passages	Relevant to claim	CLASSIFICATION OF THE APPLICATION (Int. Cl.5)
D,X	WO-A-8300136 (NCR CORPORATION) * abstract; claims 1-10; figures 1-9 *	1-3, 6-8	B65H43/00 B65H29/40
A	---	4-5	
X	GB-A-2168687 (DE LA RUE SYSTEMS LIMITED) * abstract; claims 1-8; figure 1 * * page 2, line 84 - page 3, line 61 *	1-2, 6-8	
A	---	3-5	
D,X	GB-A-2169103 (LAUREL BANK MACHINES) * abstract; claims 1-6; figures 1-10 *	1, 3, 6-8	
A	---	2, 4-5	
A	GB-A-2010226 (GAO-GESELLSCHAFT FUR AUTOMATION UND ORGANISATION MBH) * abstract; claim 1; figures 1-7b * * page 1, lines 5 - 40 * & US-A-4244565 (Cat. D)	1-8	
A	US-A-3719267 (REIST ET AL.) * abstract; claims 1-5; figures 1-3 *	1-8	
			TECHNICAL FIELDS SEARCHED (Int. Cl.5)
			B65H G07D
The present search report has been drawn up for all claims			
Place of search THE HAGUE		Date of completion of the search 17 JULY 1990	Examiner KOCH J. M. L.
CATEGORY OF CITED DOCUMENTS		I : theory or principle underlying the invention E : earlier patent document, but published on, or after the filing date D : document cited in the application L : document cited for other reasons & : member of the same patent family, corresponding document	
X : particularly relevant if taken alone Y : particularly relevant if combined with another document of the same category A : technological background O : non-written disclosure P : intermediate document			

EPO FORM 1503 (03.92) (P0401)