



⑫

## EUROPEAN PATENT SPECIFICATION

④⑤ Date of publication of patent specification :  
**19.05.93 Bulletin 93/20**

⑤① Int. Cl.<sup>5</sup> : **E02D 19/18, E02D 31/04**

②① Application number : **90201590.8**

②② Date of filing : **19.06.90**

⑤④ **Procedure for making a liquid-tight wall in the ground.**

③⑩ Priority : **30.06.89 NL 8901669**

⑦③ Proprietor : **Funderingstechnieken  
Verstraeten B.V.  
Brugsevaart 6  
NL-4501 NE Oostburg (NL)**

④③ Date of publication of application :  
**06.02.91 Bulletin 91/06**

⑦② Inventor : **Verstraeten, Alexander  
Roggelaan 15  
B-8300 Knokke-Heist (BE)**

④⑤ Publication of the grant of the patent :  
**19.05.93 Bulletin 93/20**

⑧④ Designated Contracting States :  
**BE DE FR GB NL**

⑦④ Representative : **Debrabandere, René  
Bureau De Rycker nv Arenbergstraat 13  
B-2000 Antwerpen (BE)**

⑤⑥ References cited :  
**EP-A- 0 198 666  
DE-A- 3 430 790  
DE-A- 3 430 791  
DE-A- 3 432 706  
DE-A- 3 727 202**

**EP 0 411 682 B1**

Note : Within nine months from the publication of the mention of the grant of the European patent, any person may give notice to the European Patent Office of opposition to the European patent granted. Notice of opposition shall be filed in a written reasoned statement. It shall not be deemed to have been filed until the opposition fee has been paid (Art. 99(1) European patent convention).

## Description

The invention relates to a method for making a liquid-tight wall in the ground, according to which method a first trench for a first panel is made in the ground, the trench is filled with support liquid, two auxiliary constructions with a slot provided with a seal over their height and on their sides facing each other, are installed at both extremities of the trench and a length of sealing foil is lowered between the two auxiliary constructions and the support liquid is allowed to harden, if hardenable, or is replaced by another, hardenable liquid which is allowed to harden, a second panel is made possibly partly or completely simultaneously with the first one, in the same way as the first one but at a distance from it by digging at a distance from the first trench a second trench and installing therein two auxiliary constructions and a length of the sealing foil and allowing to harden liquid in the trench, subsequently an intermediate trench for an intermediate panel is dug between said trenches and thus between two auxiliary constructions and filled with support liquid, after sufficient hardening of the liquid in the first and second trenches, the auxiliary constructions on both ends of the intermediate trench are removed, after which a length of sealing foil is lowered in the intermediate trench and the original liquid in this trench or another, hardenable replacement liquid is allowed to harden in the intermediate trench, whereby for a wall with more panels, more second panels and subsequent intermediate panels are made in the before mentioned way.

A method of this type is known from DE-A-3 430 790. According to this method, a multilayer membrane lowered in the first and second trenches, is provided with a identical female coupling part on both edges, said coupling parts being introduced in respectively two tube-like auxiliary constructions. After removing of the auxiliary constructions on both ends of the intermediary trench, a membrane provided on both edges with a male coupling part so that this part cooperates directly with a female coupling part of one of the above mentioned membranes.

The purpose of the invention is to provide a method for making a liquid-tight wall in the ground which is very simple and can also be easily utilized for great depths of the wall.

For this purpose, in the first and second trenches, before lowering the length of foil, not only two auxiliary constructions but also two joining constructions are installed, and the length of foil lowered in these trenches is connected to the auxiliary constructions by the intermediary of said joining constructions traversing slots in the auxiliary constructions, said slots being sealed, a joining element on one edge of a joining construction being present in each auxiliary construction while a joining element on the opposite edge of this joining construction coop-

erates with an edge of the length of foil, the length of foil lowered in the intermediate trench cooperating directly with its edges with the joining elements lying on both ends of this trench after removal of the auxiliary constructions on these ends.

In a particular embodiment of the invention, the joining element is installed together with the corresponding auxiliary construction in the trench.

The joining edge of a length of sealing foil can be formed by a folded over edge which forms a sleeve and a relatively stiff tube which is installed in this sleeve.

Suitably a rollable foil is utilized which is unwound from a drum in the trench, which foil is provided with weights.

In order to show better the characteristics of the present invention, some preferred embodiments of a method for making a liquid-tight wall in the ground and of a wall thus made according to the invention are described hereafter, as examples without any restrictive character, with reference to the enclosed drawings, in which:

Figures 1 through 8 are schematically maintained horizontal cross-sectional representation of a wall during successive steps of its manufacture according to the procedure of the invention;

figure 9 represents a part from the cross-section from figure 2 drawn on larger scale;

figure 10 represents a part of the cross-section from figure 3, also drawn on larger scale;

figure 11 represents a part of the cross-section from figure 8, also drawn on larger scale;

figure 12 is a detail from figure 10 drawn on still larger scale, and represented during a phase of the manufacture;

figure 13 represents the detail from figure 12 but in a later phase;

figure 14 represents a vertical cross-section of a trench after the installation of the auxiliary constructions but prior to the installation of a sealing foil;

figure 15 represents a vertical cross-section of a trench analogue to that from figure 14 but relating to a following phase of the procedure, namely during the installation of a sealing foil;

figure 16 represents a longitudinal vertical cross-section of a trench during the application of the procedure namely during the installation of a sealing foil in a trench.

In the various figures the same reference numbers relate to the same elements.

For making a watertight wall 1 in the ground 2 the following will be effected according to the invention.

A first trench 3 with a length of 3 to 8 meters and a width of 0.3 to 1.2 meters is dug with a trencher or trench excavator. During or immediately after the digging the trench 3 is filled with bentonite 4 or a mixture of bentonite and cement. The condition as represent-

ed in figure 1 is obtained.

At both extremities of the trench 3 an auxiliary construction 5 is let down vertically into the ground. This auxiliary construction 5 can consist of one element with a length of 12 to 16 meters or, if the trench 3 is deeper consist of several elements placed above each other, as represented in figures 14 and 15.

As especially appears from figures 9 and 10 in which a cross-section of an auxiliary construction is represented, each auxiliary construction 5 contains a hollow tubular base 6 to which protruding sleeves 7 connect on one side between which a slot 8 is formed. Two compressed air hoses 10, which form seals, are glued in semicircular notches 9 in the two sleeves 7 on the extremity of the slot 8.

The width of the base 6 is of course equal to the width of the trench 3. The two auxiliary constructions 5 are so placed in the trench 3 that the slots 8 are directed with their open extremity toward each other. If the auxiliary construction 5 consists of several elements not only the base 6 and the sleeve 7 of the elements located above each other are connected to each other but also the compressed air hoses 10 of these elements.

Before the two auxiliary constructions 5 are let down into the trench 3, a joining construction 11 is coupled to each auxiliary construction 5 which, as especially appears from figures 9 and 10 consists of a stiff metal strip 12 with a gutter-shaped joining element with C-shaped cross-section 13 respectively 14 on both edges. The two joining elements 13 and 14 consist of round tubes which are cut open on the side away from the strip 12. One of the joining elements 13 extends into the slot 8 of the auxiliary construction 5. The compressed air hoses 10 of the auxiliary construction 5 are inflated so that not only the slot 8 is sealed but also the joining construction 11 is fixed to the auxiliary construction 5.

As soon as the two auxiliary constructions 5 are fixed with the joining constructions 11 in the slot 3, a length 15 of a supple foil of plastic such as polyethylene with high density starts to be lowered. As especially appears from figures 15 and 16, the foil is unwound from a drum 16 mounted on a vehicle 17. In order to facilitate the lowering the bottom of the length 15 is weighted with elements 18 of metal or concrete. The two edges of the length 15 are folded over and so attached to each other by means of sewing, gluing or fusing together, that a sleeve 19 is formed into which a perforated tube 20 is slid. This tube 20 is made of plastic, relatively stiff but still supple enough to be able to be wound up on the drum 16. The diameter of the perforated tube 20 is smaller than the inside diameter of the joining elements 13 and 14. The length 15 has such a width that the two sleeves 19 with a perforated tube 20 therein formed on their edges can slide into the joining elements 14 located outside the two joining constructions 11 as is repre-

sented in detail in figure 12. The tube 20 sits with some play in the joining element 14 but cannot get out of this joining element sideways because its diameter is greater than the slot in the joining element.

As soon as the length 15 has reached the bottom of the trench, the foil is cut off above the ground and the upper extremity of the length 15 rests on the bottom. The vehicle 17 with the drum 16 can now be removed.

Subsequently the joining connection is further finished by injecting a swelling and stiffening liquid 21 such as a polyurethane mixture into the perforated tube 20. This liquid fills the entire inner space of the sleeve 19 through the perforations of the tube 20 and with that, especially during the swelling, presses the sleeve 19 against the internal wall of the joining element 14 as represented in figure 13. After the swelling and stiffening of the liquid 21 the connection between the length 15 and the joining construction 11 is watertight.

If the length 15 was installed in a mixture of bentonite and cement, then this mixture is allowed to harden or stiffen and then the first panel 22 is ready. If the slot 3 was only filled with bentonite 4 or a tixotropic liquid, then after the installation of the length 15 this liquid is replaced by another liquid 23 which hardens or stiffens. After the hardening or stiffening the first panel 22 and the condition represented in figure 2 is obtained.

In entirely the same manner as described above a second panel 22 is made at a distance from the first panel 22 that is somewhat smaller than the width of a length 15. The manufacture of the second panel 22 is therefore also started with the digging of a trench 3 as represented in figure 3. After that 2 auxiliary constructions 5 are installed in this trench each of which is provided with a joining construction 11. Finally a length 15 of foil is installed between the joining constructions 11 after which either the original support liquid is allowed to harden or stiffen in the trench 3 if this was hardenable or stiffenable, or this original liquid is replaced by new cement 23 which is hardenable or stiffenable which is then allowed to harden or stiffen. The condition represented in figure 4 with two completely formed panels 22 is obtained.

After the cement of the two panels 22 is sufficiently stiffened and hardened, a third trench 24 is dug out between the two formed panels 22 and in fact between the two neighboring auxiliary constructions 5 of these panels as represented in figure 5. This intermediate trench 24 is immediately filled with bentonite 4.

The intermediate panel 25 of the wall 1 is now formed in this intermediate trench as follows.

First of all the pressure is let out of the compressed air hoses 10 of the two auxiliary constructions 5 on both sides of the intermediate trench 24 and these auxiliary constructions 5 are removed as

represented in figure 7. A lengthened intermediate trench 24 is now obtained into which the joining elements 13 extend, which were located in the last mentioned auxiliary constructions 5.

Into the intermediate trench 24 a length 15 is installed with edges formed by the sleeves 19 in which sits a perforated tube 20, in the joining elements 13 of the two aforementioned joining constructions. After filling these sleeves 19 with a dilatible and stiffenable liquid 21 such as a polyurethane mixture, a watertight connection of this intermediate length 15 and the two joining constructions 11 is obtained.

After the replacement of the bentonite 4 by a stiffenable or hardenable liquid 23 and the stiffening and hardening of this mixture, an intermediate panel 25 is obtained as represented in figure 7 and therefore a uninterrupted wall 1 in which a seal is continuously present, namely a seal formed by three lengths 15 and joining constructions 11 situated between the lengths.

On both sides of the wall 1 as represented in figure 7 this wall can now further constructed as desired whereby therefore each time a following panel 22 is made in the above mentioned manner at a distance from the last panel and thereafter an intermediate panel 25 is made between these two panels 22.

In a variant of the above described embodiment a length 15 of plastic foil is not used but a length of a metal foil. The metal foil must be sufficiently pliable in order to be able to be rolled up. The edges of the length are then not formed by sleeves but just folded over edges of the metal foil. Because these edges have sufficiently stiffness the perforated tube 20 can be omitted.

In another variant of the above described embodiment, an additional non-perforated supple tube is installed in the perforated tube 20 which at the bottom ends under the tube 20. During the lowering of the length 15 bentonite is pumped through this additional tube which blows clean the inside of the corresponding joining element 13 or 14 in which the sleeve 19 is installed and thereby facilitates the lowering. As soon as the length 15 has reached the bottom of the trench 3 or the intermediate trench 24, this additional tube is withdrawn from the ground under simultaneous injection of the swelling liquid 21 which fills the perforated tube 20 and fills the corresponding sleeve 19 through the perforations.

Whatever the embodiment is, the procedure can be applied with relatively light cranes. The procedure can be utilized to any depth and on the spot welding is not necessary. The lengths 15 of foil can be taken relatively wide so that the number of connections between the lengths can be limited to a minimum.

The foil utilized for the length 15 is relatively inexpensive and, once it is in the ground in a hard or stiffened cement this foil is protected for ever and it can fulfill its watertight function.

The procedure is very fast and inexpensive.

The present invention is in no way restricted to the embodiments described above and shown in the figures, but such watertight walls can be implemented in different forms and dimensions and also the parts utilized in the procedure can take different forms and dimensions, without departing from the scope of the present invention as defined by the appended claims.

## Claims

1. Method for making a liquid-tight wall (1) in the ground (2), according to which method a first trench (3) for a first panel (22) is made in the ground (2), the trench is filled with support liquid (4), two auxiliary constructions (5) with a slot (8) provided with a seal (10) over their height and on their sides facing each other, are installed at both extremities of the trench (3) and a length (15) of sealing foil is lowered between the two auxiliary constructions (5) and the support liquid (4) is allowed to harden, if hardenable, or is replaced by another, hardenable liquid (23) which is allowed to harden, a second panel (22) is made possibly partly or completely simultaneously with the first one, in the same way as the first one but at a distance from it by digging at a distance from the first trench (3) a second trench (3) and installing therein two auxiliary constructions (5) and a length (15) of the sealing foil and allowing to harden liquid (4 or 23) in the trench (3), subsequently an intermediate trench (24) for an intermediate panel (25) is dug between said trenches (3) and thus between two auxiliary constructions (5) and filled with support liquid (4), after sufficient hardening of the liquid (4 or 23) in the first and second trenches (3), the auxiliary constructions (5) on both ends of the intermediate trench (24) are removed, after which a length (15) of sealing foil is lowered in the intermediate trench (24) and the original liquid (4) in this trench or another, hardenable replacement liquid (23) is allowed to harden in the intermediate trench (24), whereby for a wall with more panels, more second panels (22) and subsequent intermediate panels (25) are made in the before mentioned way, **characterized in that** in the first and second trenches (3), before lowering the length (15) of foil, not only two auxiliary constructions (5) but also two joining constructions (11) are installed, and the length (15) of foil lowered in these trenches (3) is connected to the auxiliary constructions (5) by the intermediary of said joining constructions (11) traversing slots (8) in the auxiliary constructions (5), said slots being sealed, a joining element (13) on one edge of a joining construction (15) being

- present in each auxiliary construction (5) while a joining element (14) on the opposite edge of this joining construction (11) cooperates with an edge of the length of foil (15), the length (15) of foil lowered in the intermediate trench (24) cooperating directly with its edges with the joining elements (13) lying on both ends of this trench after removal of the auxiliary constructions (5) on these ends.
2. Procedure according to claim 1, characterized in that the joining construction (11) is installed in the trench (3) together with the corresponding auxiliary construction (5).
3. Procedure according to one of the claims 1 and 2, characterized in that the joining edge (19, 20) of the length (15) in the first and second trench is equal to the joining edge (19, 20) of the length which is installed in the third trench.
4. Procedure according to one of the claims 1 through 3, characterized in that the joining edge (19, 20) of a length (15) of sealing foil is formed by a folded over edge which forms a sleeve (19) and a relatively stiff tube (9) installed therein.
5. Method according to any one of the claims 1 to 4, characterized in that the joining edge (19, 20) of a length (15) is sealed in a joining edge (13) of a joining construction (11) after the installation by means of a dilatible and hardenable liquid (21).
6. Method according to the claims 5 and 6 characterized in that as tube (20) in a sleeve forming edge (19) of a length (15) a perforated tube is utilized and the dilatible hardenable liquid (21) is injected through this perforated tube.
7. Method according to any one of the claims 4 and 6, characterized in that in order to facilitate the lowering of the length (15) into the tube (19) of a joining edge (19, 20) of the length (15) an additional tube is installed along which a lubricating liquid is squirted for cleaning the joining edge (13) of the joining construction (11) into which the joining edge (19, 20) of the length (11) must be brought.
8. Method according to any one of the claims 1 to 7, characterized in that as joining construction (11) an element is utilized consisting of a relatively stiff strip (12) which carries a gutter-shaped joining element (13 and 14) on both edges which has the shape of a tube which is cut open on the side away from the strip (12) and through which the joining edge (19, 20) of a length (15) can not get out sideways.
9. Method according to any one of the preceding claims, characterized in that as length (15) a length of rollable foil is utilized which is unwound from a drum (16), which foil is provided with weighting elements (18) in order to facilitate the lowering into a trench (3 or 24).
10. Method according to any one of the preceding claims, characterized in that as auxiliary construction (5) an element is utilized that has a base (6), two protruding parts (7) standing thereon between which a slot (8) is formed for a joining construction (11) while the seal (10) is formed by two compressed air hoses (10) which are installed in notches (9) in the protruding parts (7), in the slot (8).
11. Method according to any one of the preceding claims, characterized in that the trench (3 or 24) is first filled with bentonite or analogue liquid and after the installation of a length (15) in this trench (3 or 24) this liquid is replaced by a stiffenable or hardenable liquid (23).

#### Patentansprüche

1. Verfahren zur Herstellung einer flüssigkeitsdichten Wand (1) im Boden (2), gemäß welchen Verfahrens ein erster Schlitz (3) für ein erstes Paneel (22) im Boden (2) hergestellt wird, der Schlitz mit Stützflüssigkeit (4) gefüllt wird, zwei Hilfskonstruktionen (5) mit einer Nut (8), die mit einer Abdichtung (10) über ihre Höhe und an ihren einander gegenüberliegenden Seiten versehen ist, an beiden Enden des Schlitzes (3) angebracht werden und eine Bahn (15) Dichtungsfolie zwischen die beiden Hilfskonstruktionen (5) abgesenkt wird und man die Stützflüssigkeit (4) aushärten läßt, falls sie aushärtbar ist, oder sie durch eine andere, aushärtbare Flüssigkeit (23) ersetzt, die man aushärten läßt, ein zweites Paneel (22) möglicherweise zum Teil oder vollständig zur selben Zeit wie das erste hergestellt wird, auf dieselbe Art und Weise wie das erste, allerdings in einigem Abstand hierzu, durch Ausheben eines zweiten Schlitzes (3) in einem gewissen Abstand zum ersten Schlitz (3), und durch Anbringen von zwei Hilfskonstruktionen (5) und einer Bahn (15) Dichtungsfolie darin und durch Aushärtenlassen von Flüssigkeit (4 oder 23) in dem Schlitz (3), wonach ein Zwischenschlitz (24) für ein Zwischenpaneel (25) zwischen besagten Schlitz (3) und damit zwischen zwei Hilfskonstruktionen (5) ausgehoben und mit Stützflüssigkeit (4) gefüllt wird, nach ausreichendem Aushärten der Flüssigkeit (4 oder 23) im ersten und zweiten Schlitz (3) die Hilfskonstruktionen (5) an beiden Enden des Zwi-

- schenschlitzes (24) entfernt werden, wonach eine Bahn (15) Dichtungsfolie in den Zwischenschlitz (24) gesenkt und die Originalflüssigkeit (4) in diesem Schlitz oder eine andere, aushärtbare Ersatzflüssigkeit (23) in dem Zwischenschlitz (24) ausgehärtet wird, wobei für eine Wand mit mehr Paneelen weitere zweite Paneele (22) und anschließend Zwischenpaneele (25) in der vorgenannten Art und Weise hergestellt werden, dadurch gekennzeichnet, daß im ersten und zweiten Schlitz (3) vor dem Absenken der Folienbahn (15) nicht nur zwei Hilfskonstruktionen (5), sondern auch zwei Verbindungskonstruktionen (11) angebracht werden und die Folienbahn (15), die in diese Schlitz (3) abgesenkt wird, mit den Hilfskonstruktionen (5) mittels besagter Verbindungskonstruktionen (11), welche die Nuten (8) in den Hilfskonstruktionen (5) durchqueren, verbunden ist, wobei besagte Nuten abgedichtet sind und ein Verbindungselement (13) an einer Kante einer Verbindungskonstruktion (11) in jeder Hilfskonstruktion (5) vorhanden ist, während ein Verbindungselement (14) an der gegenüberliegenden Kante dieser Verbindungskonstruktion (11) mit einer Kante der Folienbahn (15) zusammenwirkt, wobei die Folienbahn (15), die in den Zwischenschlitz (24) abgesenkt worden ist, mit ihren Kanten direkt mit den an beiden Enden dieses Schlitzes befindlichen Verbindungselementen (13) zusammenwirkt, nachdem die Hilfskonstruktionen (5) an diesen Enden entfernt worden sind.
2. Verfahren nach Anspruch 1, dadurch gekennzeichnet, daß die Verbindungskonstruktion (11) zusammen mit der entsprechenden Hilfskonstruktion (5) in dem Schlitz (3) angebracht ist.
3. Verfahren nach einem der Ansprüche 1 und 2, dadurch gekennzeichnet, daß die Verbindungskante (19, 20) der Bahn (15) im ersten und zweiten Schlitz der Verbindungskante (19, 20) der Bahn, welche im dritten Schlitz angebracht wird, entspricht.
4. Verfahren nach einem der Ansprüche 1 bis 3, dadurch gekennzeichnet, daß die Verbindungskante (19, 20) einer Bahn (15) Dichtungsfolie durch eine umgefaltete Kante, die eine Röhre (19) bildet, und ein relativ steifes Rohr (9), welches darin angebracht ist, gebildet wird.
5. Verfahren nach einem der vorgenannten Ansprüche 1 bis 4, dadurch gekennzeichnet, daß die Verbindungskante (19, 20) einer Bahn (15) in einer Verbindungskante (13) einer Verbindungskonstruktion (11) nach dem Anbringen mittels einer ausdehnungsfähigen und aushärtbaren Flüssigkeit (21) abgedichtet wird.
6. Verfahren nach den Ansprüchen 5 und 6, dadurch gekennzeichnet, daß als Rohr (20) in einer eine Röhre bildenden Kante (19) einer Bahn (15) ein perforiertes Rohr benutzt wird und die ausdehnungsfähige aushärtbare Flüssigkeit (21) durch dieses perforierte Rohr injiziert wird.
7. Verfahren nach einem der vorgenannten Ansprüche 4 und 6, dadurch gekennzeichnet, daß, um das Absenken der Bahn (15) zu erleichtern, in dem Rohr (19) einer Verbindungskante (19, 20) einer Bahn (15) ein zusätzliches Rohr angebracht wird, durch welches eine Gleitflüssigkeit gespritzt wird, um die Verbindungskante (13) der Verbindungskonstruktion (11), in welche die Verbindungskante (19, 20) der Bahn (15) eingebracht werden muß, zu reinigen.
8. Verfahren nach einem der Ansprüche 1 bis 7, dadurch gekennzeichnet, daß als Verbindungskonstruktion (11) ein Element verwendet wird, das aus einer relativ steifen Leiste (12) besteht, welche an beiden Kanten ein rinnenförmiges Verbindungselement (13 und 14) in Form eines Rohrs aufweist, das an der der Leiste (12) gegenüberliegenden Seite aufgeschnitten ist und durch welches die Verbindungskante (19, 20) einer Bahn (15) seitlich nicht heraustreten kann.
9. Verfahren nach einem der vorgenannten Ansprüche, dadurch gekennzeichnet, daß als Bahn (15) eine Bahn aufrollbarer Folie benutzt wird, die von einer Trommel (16) abgespult wird, wobei diese Folie mit Gewichten (18) versehen ist, um das Absenken in einen Schlitz (3 oder 24) zu erleichtern.
10. Verfahren nach einem der vorgenannten Ansprüche, dadurch gekennzeichnet, daß als Hilfskonstruktion (5) ein Element benutzt wird, das eine Basis (6) und zwei daraufstehende hervorstehende Teile (7) aufweist, zwischen denen eine Nut (8) für eine Verbindungskonstruktion (11) gebildet wird, während die Abdichtung (10) durch zwei Druckluftschläuche (10) gebildet wird, die in Rinnen (9) in den vorstehenden Teilen (7) in der Nut (8) angebracht sind.
11. Verfahren nach einem der vorgenannten Ansprüche, dadurch gekennzeichnet, daß der Schlitz (3 oder 24) zunächst mit Bentonit oder einer entsprechenden Flüssigkeit verfüllt und nach dem Anbringen einer Bahn (15) in diesem Schlitz (3 oder 24) diese Flüssigkeit durch eine versteifbare oder aushärtbare Flüssigkeit (23) ersetzt wird.

## Revendications

1. Procédé pour fabriquer une paroi (1) étanche aux liquides dans le sol (2), procédé selon lequel on réalise une première tranchée (3) pour un premier panneau (22) dans le sol (2), on remplit la tranchée avec un liquide de support (4), on installe aux deux extrémités de la tranchée (3) deux constructions auxiliaires (5) munies d'une fente (8) équipée d'un joint étanche (10) sur leur hauteur et sur leurs faces mutuellement opposées, et on abaisse une longueur (15) de feuille d'étanchéification entre les deux constructions auxiliaires (5) et on laisse se durcir le liquide de support (4), s'il est durcissable, ou on le remplace par un autre liquide durcissable (23) qu'on laisse durcir, on réalise un second panneau (22) éventuellement en partie ou tout à fait simultanément au premier, de la même manière que le premier, mais à distance du premier en creusant, à une certaine distance de la première tranchée (3), une seconde tranchée (3) et en y installant deux constructions auxiliaires (5), ainsi qu'une longueur (15) de feuille d'étanchéification et en laissant durcir le liquide (4 ou 23) dans la tranchée (3), ensuite on creuse une tranchée intermédiaire (24) pour un panneau intermédiaire (25) entre lesdites tranchées (3) et ainsi entre deux constructions auxiliaires (5), et on la remplit avec du liquide de support (4); après un durcissement suffisant du liquide (4 ou 23) dans les première et seconde tranchées (3), on retire les constructions auxiliaires (5) aux deux extrémités de la tranchée intermédiaire (24), après quoi on abaisse une longueur (15) d'une feuille d'étanchéification dans la tranchée intermédiaire (24) et on laisse durcir le liquide initial (4) dans cette tranchée ou bien un autre liquide de remplacement durcissable (23) dans la tranchée intermédiaire (24), dans lequel, pour obtenir une paroi comprenant plusieurs panneaux, on réalise une quantité supplémentaire de seconds panneaux (22) et de panneaux intermédiaires ultérieurs (25) de la manière mentionnée ci-dessus, caractérisé en ce que, dans les première et seconde tranchées (3), avant d'abaisser la longueur (15) de feuille, on installe non seulement deux constructions auxiliaires (5), mais également deux constructions de jonction (11) et on relie la longueur (15) de feuille abaissée dans ces tranchées (3) aux constructions auxiliaires (5) par l'intermédiaire desdites constructions de jonction (11) traversant des fentes (8) pratiquées dans les constructions auxiliaires (5), lesdites fentes étant étanchées, un élément de jonction (13) sur un bord d'une construction de jonction (15) étant présent dans chaque construction auxiliaire (5), tandis qu'un élément de jonction (14) sur le bord opposé de cette construction de jonction (11) coopère avec un bord de la longueur (15) de feuille, la longueur (15) de feuille abaissée dans la tranchée intermédiaire (24) coopérant directement par ses bords avec les éléments de jonction (13) disposés aux deux extrémités de cette tranchée après retrait des constructions auxiliaires (5) à ces extrémités.
2. Procédé selon la revendication 1, caractérisé en ce que la construction de jonction (11) est installée dans la tranchée (3), conjointement avec la construction auxiliaire correspondante (5).
3. Procédé selon une des revendications 1 et 2, caractérisé en ce que le bord de jonction (19, 20) de la longueur (15) dans les première et seconde tranchées est égal aux bords de jonction (19, 20) de la longueur qui est installée dans la troisième tranchée.
4. Procédé selon une des revendications 1 à 3, caractérisé en ce que le bord de jonction (19, 20) d'une longueur (15) d'une feuille d'étanchéification est formé par un bord replié qui forme un manchon (19) et par un tube relativement rigide (9) installé en son sein.
5. Procédé selon l'une quelconque des revendications 1 à 4, caractérisé en ce que le bord de jonction (19, 20) d'une longueur (15) est étanché dans un bord de jonction (13) d'une construction de jonction (11) après l'installation au moyen d'un liquide dilatable et durcissable (21).
6. Procédé selon les revendications 4 et 5, caractérisé en ce que, comme tube (20) dans un bord (19) d'une longueur (15) formant un manchon, on utilise un tube perforé et on injecte le liquide dilatable durcissable (21) à travers ce tube perforé.
7. Procédé selon l'une quelconque des revendications 4 et 6, caractérisé en ce que, afin de faciliter l'abaissement de la longueur (15) dans le tube (19) d'un bord de jonction (19, 20) de la longueur (15), on installe un tube supplémentaire le long duquel on projette un liquide lubrifiant pour nettoyer le bord de jonction (13) de la construction de jonction (11), dans lequel on doit amener le bord de jonction (19, 20) de la longueur (11).
8. Procédé selon l'une quelconque des revendications 1 à 7, caractérisé en ce que, comme construction de jonction (11), on utilise un élément consistant en une bande relativement rigide (12) qui porte, sur ses deux bords, un élément de jonction en forme de gouttière (13 et 14), qui a la forme d'un tube qui est ouvert par découpage du côté s'écartant de la bande (12) et à travers le-

quel le bord de jonction (19, 20) d'une longueur (15) ne peut sortir latéralement.

9. Procédé selon l'une quelconque des revendications précédentes, caractérisé en ce que, comme longueur (15), on utilise une longueur de feuille enroulable qu'on déroule d'un tambour (16), ladite feuille étant munie d'éléments (18) donnant du poids afin de faciliter l'abaissement dans une tranchée (3 ou 24). 5 10
10. Procédé selon l'une quelconque des revendications précédentes, caractérisé en ce que, comme construction auxiliaire (5), on utilise un élément qui possède une base (6), deux parties saillantes (7) dressées par-dessus cette dernière, entre lesquelles une fente (8) est façonnée pour une construction de jonction (11), tandis que le joint étanche (10) est formé par deux tuyaux (10) à air comprimé, qui sont installés dans des encoches (9) pratiquées dans les parties saillantes (7), dans la fente (8). 15 20
11. Procédé selon l'une quelconque des revendications précédentes, caractérisé en ce que la tranchée (3 ou 24) est d'abord remplie de bentonite ou d'un liquide analogue et, après l'installation d'une longueur (15) dans cette tranchée (3 ou 24), on remplace ce liquide par un liquide rigidifiable ou durcissable (23). 25 30

35

40

45

50

55

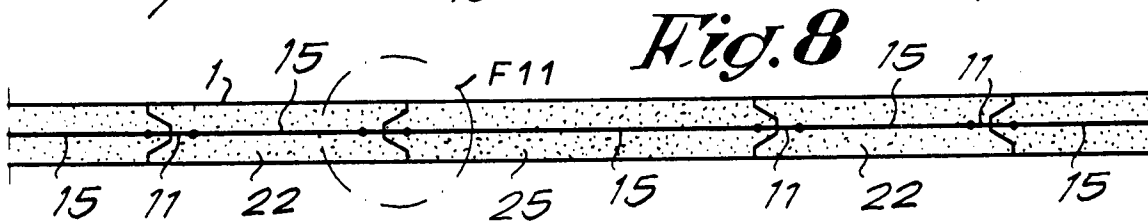
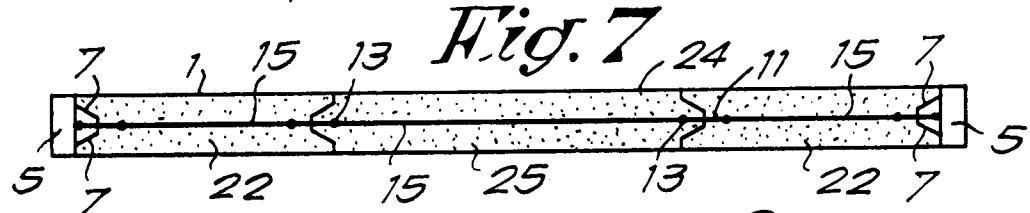
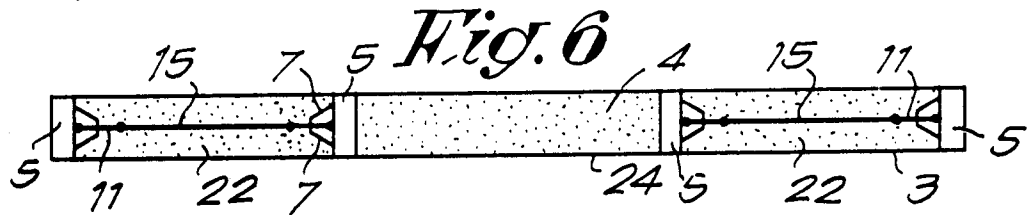
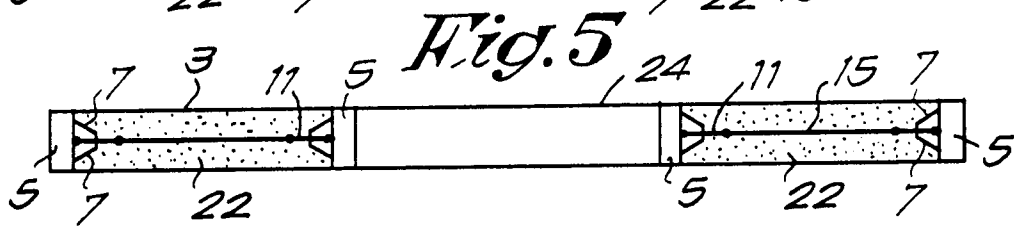
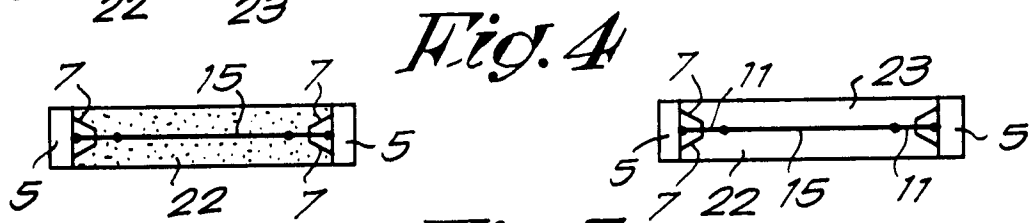
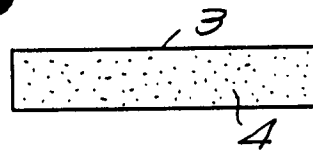
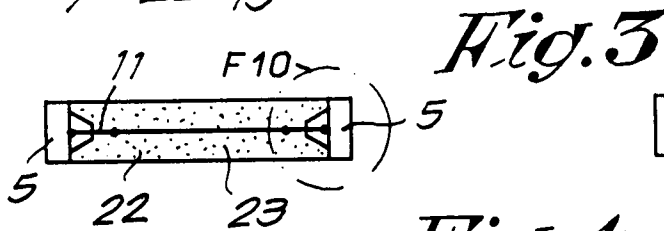
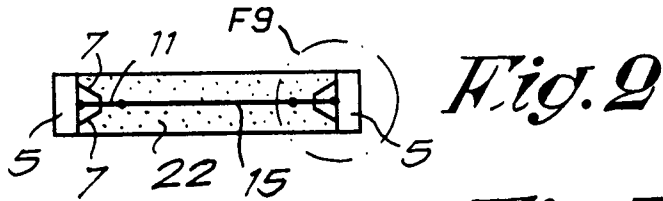
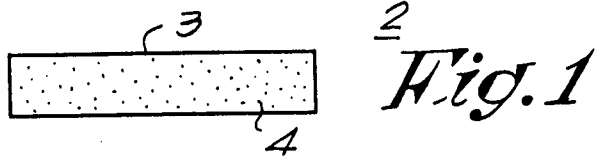

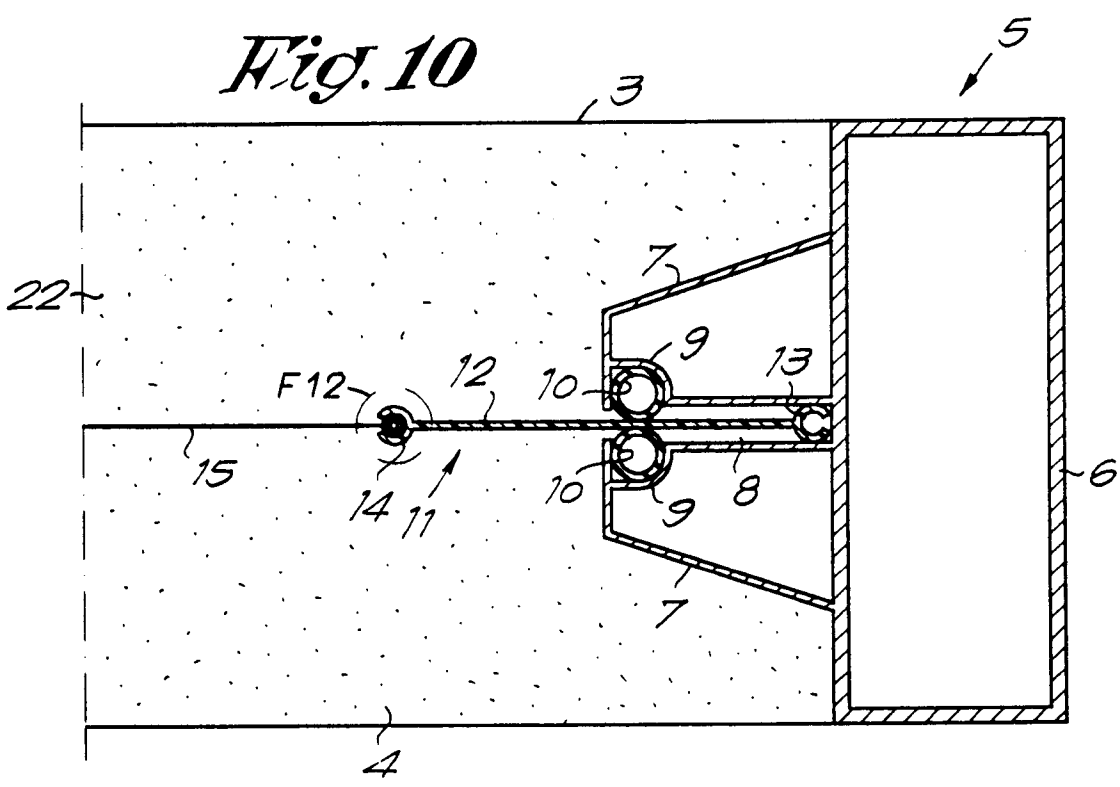
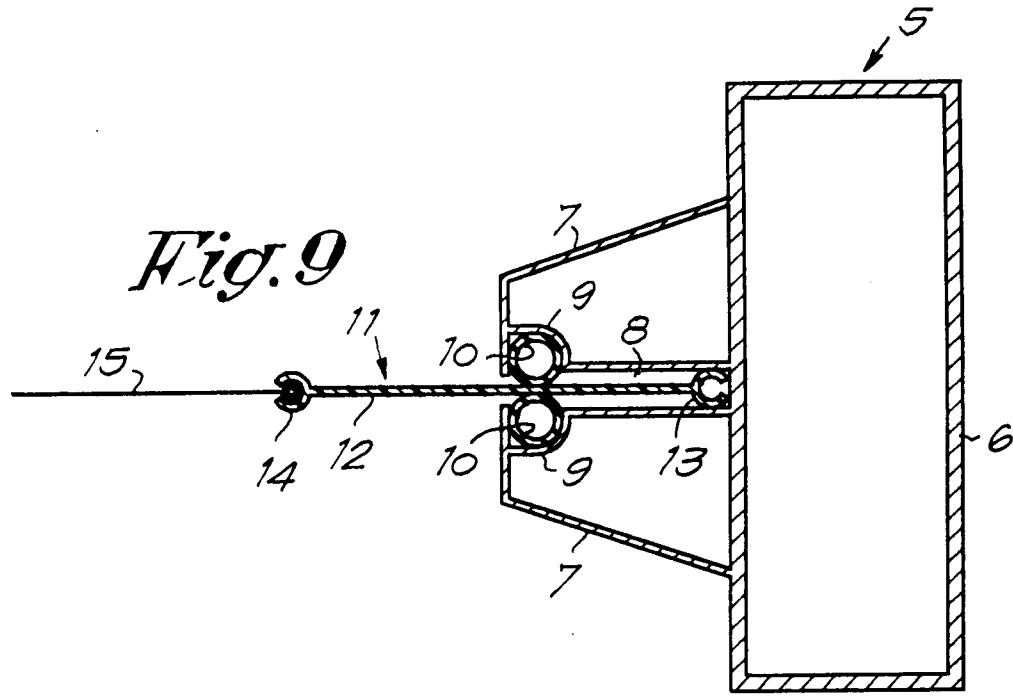

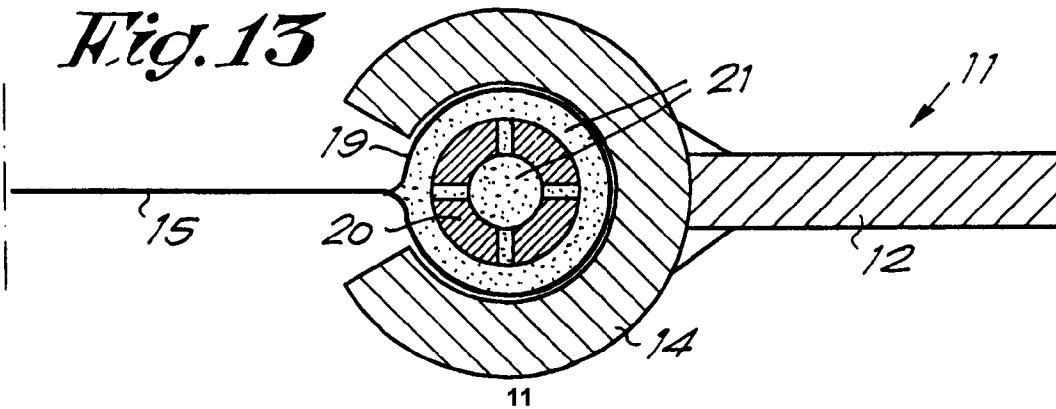
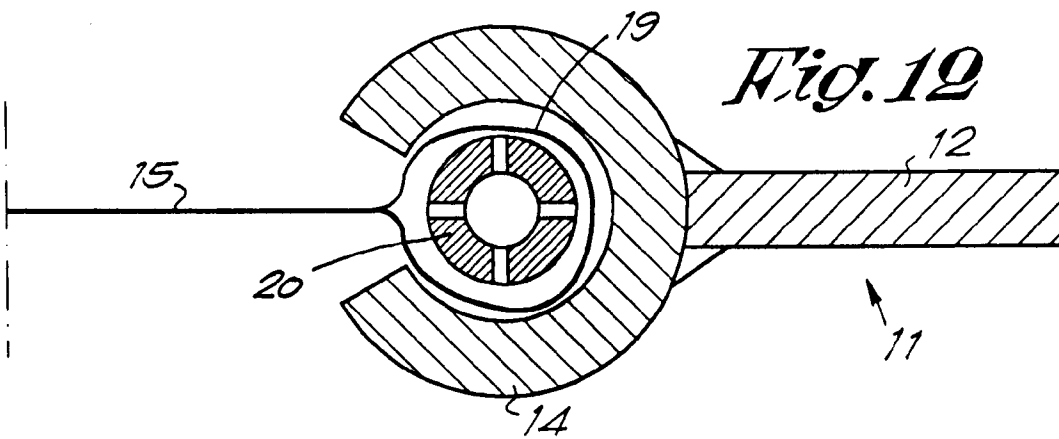
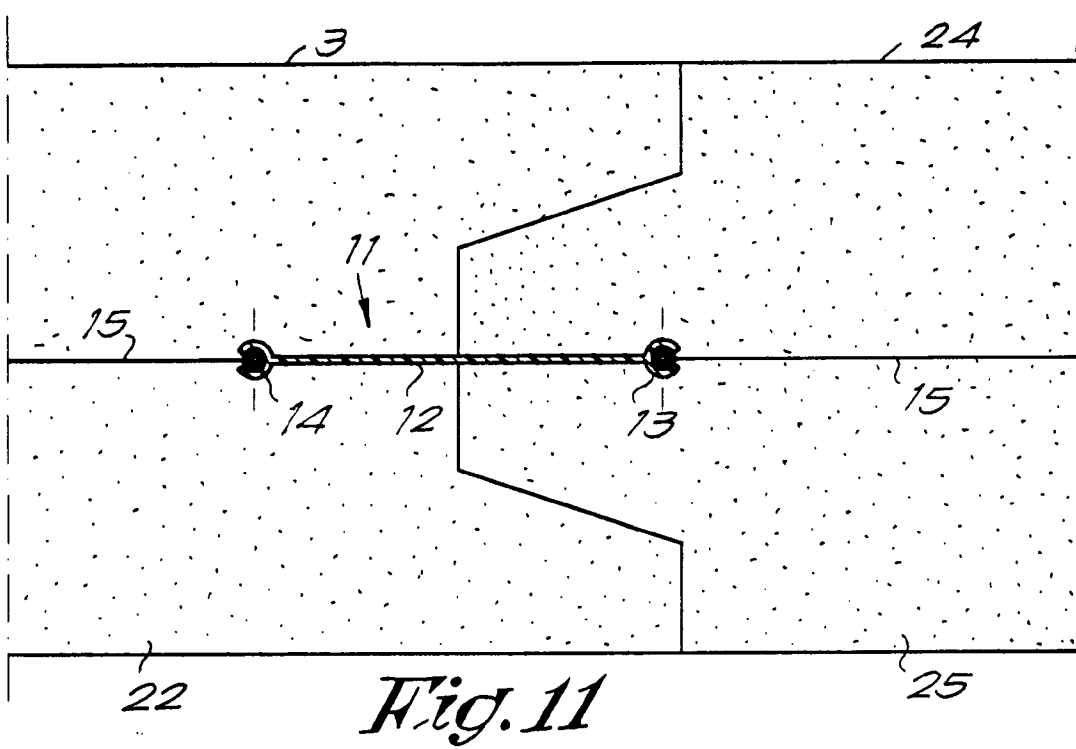

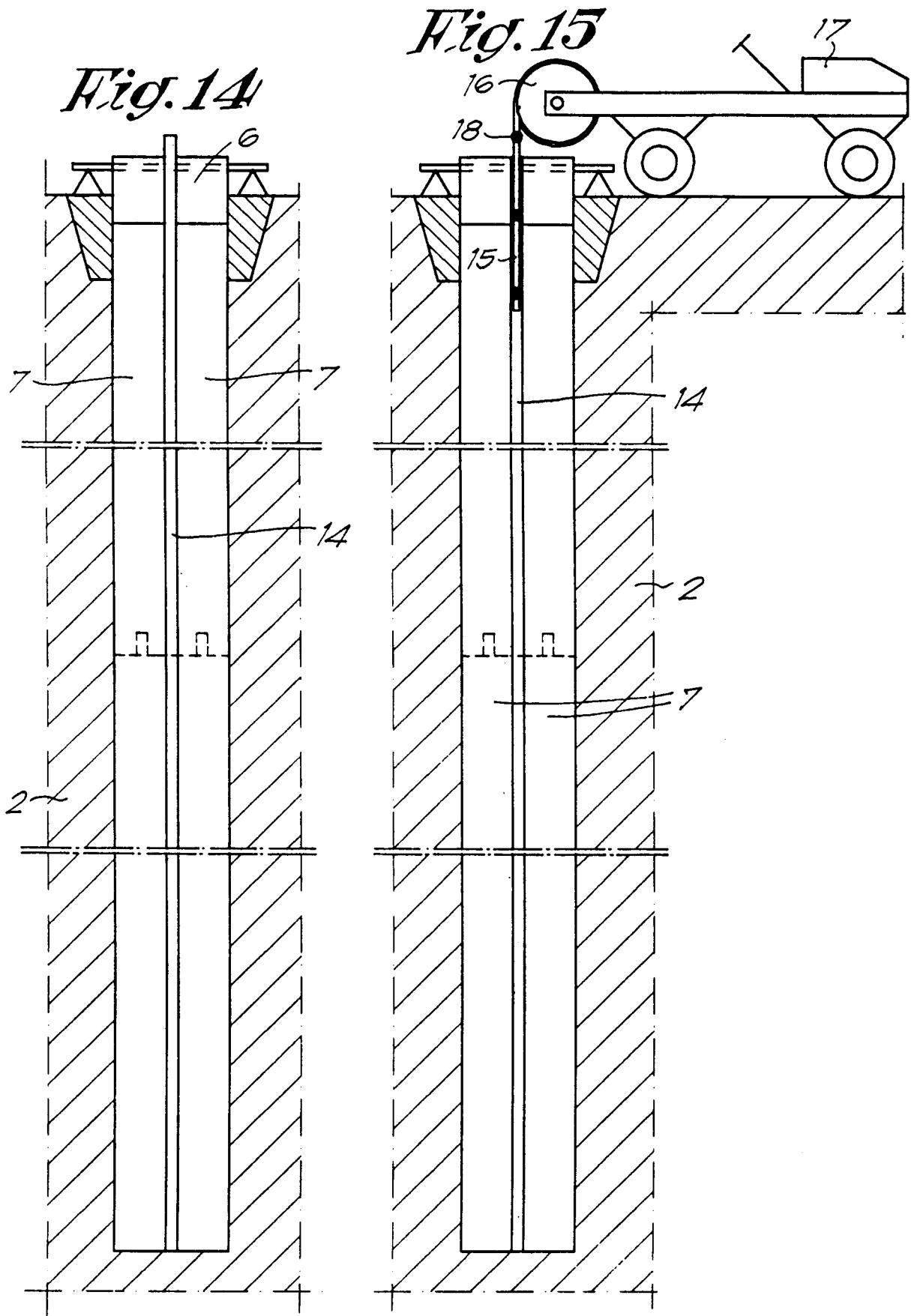

*Fig. 16*

