

(19)



Europäisches Patentamt

European Patent Office

Office européen des brevets



(11)

**EP 0 411 892 B1**

(12)

**EUROPEAN PATENT SPECIFICATION**

(45) Date of publication and mention of the grant of the patent:

**20.03.1996 Bulletin 1996/12**

(51) Int. Cl.<sup>6</sup>: **A63B 21/22**, A63B 23/02

(21) Application number: **90308400.2**

(22) Date of filing: **31.07.1990**

**(54) Energy absorbing exercising and training machine**

Energiespeicherndes Übungsgerät

Appareil d'entraînement et d'exercice à absorption d'énergie

(84) Designated Contracting States:  
**AT BE CH DE DK ES FR GB GR IT LI LU NL SE**

• **Webb, John Douglas**  
**Pinellas, Florida (US)**

(30) Priority: **01.08.1989 US 388116**

(74) Representative: **Gold, Tibor Z. et al**  
**Stephenson Harwood**  
**One, St. Paul's Churchyard**  
**London EC4M 8SH (GB)**

(43) Date of publication of application:  
**06.02.1991 Bulletin 1991/06**

(73) Proprietor: **Douglas, D. Scott**  
**Clearwater, Pinellas, Florida (US)**

(56) References cited:  
**US-A- 4 077 626**                      **US-A- 4 296 924**  
**US-A- 4 305 579**                      **US-A- 4 732 381**

(72) Inventors:  
• **Douglas, D. Scott**  
**Pinellas, Florida (US)**

**EP 0 411 892 B1**

Note: Within nine months from the publication of the mention of the grant of the European patent, any person may give notice to the European Patent Office of opposition to the European patent granted. Notice of opposition shall be filed in a written reasoned statement. It shall not be deemed to have been filed until the opposition fee has been paid. (Art. 99(1) European Patent Convention).

**Description**

BACKGROUND OF THE INVENTION

Field of the Invention

This invention relates to exercising and training machines. More particularly, this invention relates to exercising and training machines for exercising a person's ability to accelerate a portion of his body through a path of motion, such as which occurs during a baseball or golf swing.

Description of the Background Art

Presently there exist many types of exercising and training machines designed to exercise portions of a person's body. The most predominant type of exercising and training machine utilizes weight resistance which, through repetition, builds the person's muscles.

United States Patent 4,296,924 disclose a torsion exercise apparatus including adjustable weights which may be raised by rotational movement of a wheel about a vertical axes to which is connected a pair of handles and crossbar for cradling the user's shoulders, arms and hands therein. Rotational movement of the user's torso causes the wheel to rotate about the vertical axis to raise and lower the weights, thereby exercising the user's torso.

Additionally, there exists a need for an exercise and training machine which exercises a person's ability to accelerate a portion of his body through a path of motion, such a what occurs during the swinging of a baseball bat or a golf club. There also exists a need for an exercising and training machine which isolates individual muscle groups and measures acceleration of a portion of a person's body. Indeed, many professional athletes such a golfers and baseball players refrain from resistance weight training during season in fear of adversely affecting their flexibility and ability to swing their golf club or baseball bat in a controlled manner.

Therefore, it is an object of this invention to provide an apparatus which overcomes the aforementioned inadequacies of the prior art devices and provides an improvement which is a significant contribution to the advancement of the exercising art.

Another object of this invention is to provide an exercising and training machine which exercises and trains a person's ability to accelerate a portion of his body through a path of motion.

Another object of this invention is to provide an exercising and training machine which is to be utilized by golfers in exercising their golf swing.

Another object of this invention is to provide an exercising and training machine to be used by golfers in exercising their backswing.

Another object of this invention is to provide an energy absorbing exercising machine which allows the user to regulate the amount of resistance in accordance

with the user's physical ability and which can, therefore, be used for rehabilitation of muscles.

Another object of this invention is to provide an energy absorbing exercising and training machine which allows a person to time the release of energy at the instant of the most importance.

The foregoing has outlined some of the more pertinent objects of the invention. These objects should be construed to be merely illustrative of some of the more prominent features and applications of the intended invention. Many other beneficial results can be obtained by applying the disclosed invention in a different manner or modifying the invention within the scope of the disclosure. Accordingly, other objects and a fuller understanding of the invention may be had by referring to the summary of the invention and the detailed description of the preferred embodiment in addition to the scope of the invention defined by the claims taken in conjunction with the accompanying drawings.

SUMMARY OF THE INVENTION

The invention is defined by the appended claims with a specific embodiment shown in the attached drawings. For the purpose of summarizing the invention, the invention comprises an energy absorbing exercising and training machine for exercising a person's ability to accelerate a portion of his body through a path of motion, including an energy-storing device e.g. a flywheel rotatably connected to a frame by means of a pair of journal bearings. A harness assembly is provided for connection to the portion of the person,s body to be exercised. Means are provided for interconnecting the flywheel and the harness assembly allowing the flywheel to rigidly engage relative to the harness assembly upon acceleration of the harness assembly relative to the flywheel in a first direction along the path of motion of the body portion being exercised. The interconnecting means also allows the flywheel to disengage and freely rotate relative to the harness assembly upon deceleration of the harness assembly relative to the flywheel.

The body portion being exercised may therefore be forcibly accelerated in the first direction along the path of motion against the inertia of the flywheel. Upon deceleration of the body portion, the flywheel disengages relative to the harness assembly thereby precluding the inertia of the flywheel from exerting a force on the body portion along the path of motion. In the preferred embodiment, the interconnecting means comprises an overrunning clutch having an inner race mounted to a shaft which is connected to the flywheel and journaled in the pair of bearings and having an outer race connected relative to the harness assembly.

The exercising and training machine of the invention may be utilized in conditioning and training for many sports and other activities that encourage the rapid acceleration of a portion of the person's body, such as occurs in baseball, golf, and other swing-type activities. The machine is also usable in exercising individual muscle

groups that are customarily exercised through weight lifting exercises like bench presses, bi-ceps curls and overhead presses. The exercising and training machine is described herein as being utilized in conditioning for golf by exercising the twisting acceleration of the golfer's torso and legs during a golf swing.

Specifically, when utilized as a torso and legs exercising machine for golfers, the exercising and training machine of the invention comprises a stand which adjustably positions the flywheel, shaft, and overrunning clutch in a position above the golfer's head, with the harness assembly connected to the lowermost end of the shaft by means of a universal joint, preferably a constant velocity universal joint. The harness assembly comprises an inverted substantially U-shaped or V-shaped rigid configuration for fitting over the shoulders and upper torso of the golfer's body. The universal joint allows the torso harness assembly to universally pivot during the golf swing.

Preferably, the frame comprises a carried frame that is operatively connected to the stand by means of slide bearings which allow the frame, flywheel, shaft and torso harness assembly to freely reciprocate sideways above the golfer's head, the sideways movement being geared to the rotation of the torso harness of the shaft. Furthermore, the shaft is preferably slidably journaled within the pair of journal bearings and the inner race of the over-running clutch to allow the shaft to easily reciprocate vertically. The sideways movement of the carried frame, the vertical movement of the shaft, and the pivoting of the torso harness assembly via the universal joint allows the golfer to exercise and be trained in a recommended golf swing which requires canting and vertical and sideways movement of the golfer's torso during the backswing and through the golf swing.

It should be appreciated that during the golf swing, the golfer's torso may accelerate to his fullest ability and the energy created thereby forces the flywheel into accelerating rotational movement and such energy is absorbed. When the golfer's torso begins to decelerate at the end of the golf swing, the overrunning clutch disengages the shaft allowing the flywheel to freely rotate. Thus, the inertia of the rotating flywheel does not exert a force on the golfer's torso once the golfer's torso begins to decelerate or stop. Over-twisting and possible physical damage are therefore precluded.

When the exercising and training machine of the invention is adapted to be utilized as a golf exercising and training machine, it may additionally include means for providing resistance to the golfer's torso during the backswing and partial extension of the torso at the end of the backswing immediately prior to beginning the golf swing. More particularly, such means may comprise a cammed clutch for interconnecting the flywheel and the shaft. The cammed clutch allows the flywheel to rigidly engage the shaft only during a predefined arc of rotation which corresponds to the arcuate path of motion of the backswing. Thus, during the predefined arc of rotation, the flywheel is rigidly connected relative to the harness

and provides inertial resistance to the golfer's torso during the backswing. Toward the end of the backswing, the inertia of the flywheel forces slight extension of the golfer's torso immediately prior to the golfer exerting energy by twisting his torso in the opposite direction corresponding to a golf swing thereby overcoming the inertia of the flywheel and reversing its direction. Alternatively, the cammed clutch may be adjusted to disengage the flywheel from the shaft at a predefined end of the backswing to preclude overextension of the golfer's torso and possible physical damage.

Finally, a transducer may be operatively connected to the frame to sense the rotational speed of the flywheel over time, which information is then fed into a displayed device to inform the golfer of his progressive ability to accelerate the flywheel. Additional transducers may also be operatively connected to the frame to sense the vertical movement of the shaft, the sideways shifting of the frame and the angular position of the torso harness assembly relative to the shaft. All of such information may then be supplied to a computer and analyzed to determine the quality of the golf swing.

The foregoing has outlined rather broadly the more pertinent and important features of the present invention in order that the detailed description of the invention that follows may be better understood so that the present contribution to the art can be more fully appreciated. Additional features of the invention will be described hereinafter which form the subject of the claims of the invention. It should be appreciated by those skilled in the art that the conception and the specific embodiment disclosed may be readily utilized as a basis for modifying or designing other structures for carrying out the same purposes of the present invention. It should also be realized by those skilled in the art that such equivalent constructions do not depart from the scope of the invention as set forth in the appended claims.

#### BRIEF DESCRIPTION OF THE DRAWINGS

For a fuller understanding of the nature and objects of the invention, reference should be had to the following detailed description taken in connection with the accompanying drawings in which:

Fig. 1 is a perspective view of the exercising and training machine of the invention illustrating the carried frame reciprocatably mounted to a vertically adjustable stand and illustrating the flywheel rotatably journaled to the carried frame by means of a shaft with a torso harness assembly depending therebelow for exercising the torso and legs of a golfer; Fig. 2 is a rearward perspective view of the torso harness assembly illustrating the inverted substantially V-shaped configuration thereof and the universal joint which interconnects the torso harness assembly with the lowermost end of the shaft;

Fig. 3 is a top view of the exercising and training machine of the invention;

Fig. 4 is a cross-sectional view of Fig. 3 along lines 4-4 illustrating the over-running clutch which interconnects the flywheel to the shaft for rigid engagement therewith in a first direction corresponding to the golf swing and which illustrates the cammed clutch which rigidly interconnects the flywheel to the shaft during the backswing; and

Fig. 5 is an enlarged cross-sectional view of the over-running clutch, cammed clutch and upper and lower journal bearings.

Similar reference characters refer to similar parts throughout the several views of the drawings.

#### DETAILED DESCRIPTION OF THE PREFERRED EMBODIMENT

Referring to Fig. 1, the exercising and training machine 10 of the invention comprises a carriaged frame 12 reciprocatably mounted within a vertically adjustable stand, generally indicated by numeral 14. A flywheel 16 is rotatably mounted to the carriaged frame 12 by means of a shaft 18. A torso harness assembly 20 is pivotably connected to the lowermost end of the shaft 18 by means of a universal joint 22. The torso harness assembly 20 is configured to fit over a golfer's shoulders and onto his torso as shown in Figure 1. As described below in greater detail, the exercising and training machine 10 exercises and trains the golfer's ability to accelerate his torso through a twisting path of motion in a first direction corresponding to a proper golf swing. As also described below in greater detail, the exercising and training machine 10 of the invention also allows the golfer to forcibly move his torso in a second direction opposite to that of the first direction corresponding to a backstroke and further allows extension of the golfer's torso at the end of the golf swing.

As shown in Fig. 2, the torso harness assembly 20 comprises a horizontal member 24 having a substantially horizontal bracket 26 welded thereto and inverted, substantially V-shaped arms 28 extending downwardly from opposing ends thereof. The universal joint 22 is rigidly secured to the bracket 26 by means of threaded fasteners or the like. Inwardly extending pad members 30 are rigidly connected to the arms 28.

As shown in Fig. 1, the inverted V-shaped arms 28 straddle the golfer's head and slide over the golfer's shoulders onto his torso; the horizontal member 24 being positioned sufficiently above the golfer's head so as not to interfere therewith. As thus configured, the golfer's torso is firmly received within the torso harness assembly 20 and any rotational or other movement of the torso is transferred to the shaft 18 via universal joint 22. Preferably, universal joint 22 comprises a constant velocity universal joint.

Referring to Figs. 3 and 4, stand 14 comprises a generally rectangular framework having front, rear and left and right side members 32F, 32R, 32LS and 32RS, respectively, rigidly connected together to define a gen-

erally rectangular configuration having an opened center 32 $\theta$ . A bracket 34 extends from the front 32F and rear 32R frame members for rigid connection to respective cylindrical support guides or collars 36. Each support guide 36 is slideably fitted over an upstanding cylindrical support tube or pipe 38. The tubes 38 are rigidly secured in their upright position to a ground platform 40 (see Fig. 1).

The rectangular framework 32 is vertically adjustable along the length of the tubes 38. Specifically, vertical adjustment is provided by means of rotatable lifting rings 42 positioned about the respective tubes 38, each of which include a plurality of off-axis roller bearing 44 which causes the lifting ring 42 to ascend the tube 38 when rotated in one direction and descend the tube 38 when rotated in the other direction. Thus, the height of the rectangular framework 32 may be easily adjusted by rotation of the lifting ring 42 on each tube 38.

The carriaged frame 12 comprises a generally rectangular framework 46 oriented vertically and having top and bottom frame members 46T and 46B and front and rear frame members 46F and 46R rigidly connected together at their respective corners to define a substantially rectangular configuration. The rectangular framework 46 of the carriaged frame is dimensioned to fit within the opening 32 $\theta$  defined by the rectangular framework 32 of the stand 14.

The rectangular framework 46 of the carriaged frame 12 is supported by the rectangular framework 32 of the stand 14 by means of a pair of rails 48 which are rigidly secured to left and side frame members 32LS and 32RS of the framework 32 of the stand 14 to span the central opening 32 $\theta$  thereof. Slide bearings 50 are rigidly connected to the underside of the top frame member 46T of the rectangular framework 46 of the carriaged frame 12 for slideable engagement with rails 48, thereby allowing the carriaged frame 12 to reciprocate sideways within the opening of the rectangular framework 32 of the stand 14.

As shown in Fig. 5, the shaft 18 is rotatably journaled to the carriaged frame 12 by means of a pair of journal bearings 52 connected to the top and bottom frame members 46T and 46B of the rectangular framework 46. Preferably, shaft 18 comprises a spline shaft and the upper journal bearing 52 includes a sleeve 52B and a ball spline bearing 54 with keyway 51 which allows the shaft 18 to reciprocate vertically relative to the journal bearing 52U and rotate. A stop 56 is connected to the upper end of the shaft 18 by means of threaded fastener 58. Spring 60 is positioned between stop 56 and the sleeve 52B for cushioning.

Preferably, the sideways movement of the carriaged frame 12 is geared to the rotation of the shaft 18 by means of a cable 53 which is wrapped once around the sleeve 52B and the trailing ends 55 of the cable 53 are rigidly connected to the left and right side members 32LS and 32RS of the rectangular framework 32. Thus, it can be appreciated that rotation of the harness assembly 20, shaft 18 and sleeve 52B causes the carriaged frame 12

to travel sideways along the length of the cable 53. Preferably, the cable 53 is wrapped about the sleeve 52B in such a manner that the carried frame 12 is in its fully rightward position when the harness assembly 20 is rotated to a position corresponding to the start of the golfer's swing. Thus, as the golfer takes his golf swing, the carried frame 12 is forcibly moved leftward in synchronism with the rotation of the golfer's torso, thereby training the golfer to exercise a proper golf swing.

The flywheel 16 comprises a generally disk-shaped configuration (see Fig. 3). A plurality of upstanding pins 62 are positioned equidistantly about an outer periphery of the flywheel 16 for receiving removable weights 64 to attain a flywheel having a desired mass.

The flywheel 16 is rigidly connected to the upper protruding portion of the lower sleeve bushing 52LB by means of welding 66 or the like. The flywheel 16 is operatively connected to the shaft 18 by means of an over-running clutch 68 having an outer raceway 680 rigidly connected at a lower surface to the flywheel 16 by means of threaded fasteners 70. A ball spline bearing 72 is positioned within the inner raceway 681 of the clutch 68 and is keyed thereto by means of keyway 74. Ball spline bearing 72 allows vertical movement of the shaft 18 there-through while nonrotatably securing the inner raceway 681 to the shaft 18. A shim bushing 76 may be interposed between the inner raceway 681 and the spline bearing 72.

Rotation of shaft 18 in one direction causes the inner raceway 681 to rigidly engage the outer raceway 680 of the clutch 68 thereby rigidly interconnecting the flywheel 16 to the shaft 18. Deceleration of the shaft 18 relative to the flywheel 16 causes the raceway 680 and 681 to disengage allowing the flywheel 16 to freely over-run without exerting any torque on the shaft 18. Thus, with the torso harness assembly 20 connected to the end of the shaft 18, it can be readily appreciated that the golfer's twisting of his torso during the golf swing will forcibly accelerate the flywheel 16 and, at the end of the golf swing when the torso begins to decelerate, the flywheel 16 freely overruns to prevent any force being imparted to the torso harness assembly 20 which would otherwise adversely affect the golf swing and possibly cause physical damage to the golfer.

The exercising and training machine 10 of the invention further includes a cammed clutch, generally indicated by numeral 78, which interconnects the flywheel 16 and the shaft 18 and allows the flywheel 16 to rigidly engage the shaft 18 during a predefined arc of rotation of the shaft in a second direction corresponding to the golfer's backswing opposite to the first direction corresponding to the golfer's golf swing.

More particularly, the cammed clutch 78 comprises a first clutch plate 80 which is rigidly connected to the upper sleeve bushing 52LB of the upper journal bearing 52. The cammed clutch 78 further comprises a second clutch plate 82 positioned in alignment with the first clutch plate 80 and rigidly connected to the upper surface of the outer raceway 680 of the over-running clutch 68 by means of threaded fastener 84. A wearable clutch 86

is positioned between the clutch plates 80 and 82. An arcuate cam 88 is rigidly connected to the upper surface of the first clutch plate 80 and includes end ramp 88R. A corresponding cam roller 90 is rotatably connected to a bracket 92 depending from the top frame member 46T of the rectangular framework 46 in alignment with cam 88. A lower cam roller 94 may also be rotatably connected to bracket 92 for support to the underside of the second clutch plate 82.

The cam 88 is arcuately shaped to be engaged by the cam roller 90 along the predefined arc of rotation which corresponds to the backswing of the golfer when the golfer is facing forwardly. Thus, as the golfer begins his backswing, cam roller 90 engages cam 88 to frictionally engage the clutch plates 80 and 82 together and rigidly interconnects the flywheel 16 to the shaft 18 via sleeve 52B and ball spline bearing 54. The golfer must thus exert enough backswing force to rotate flywheel 16. At the end of the golfer's backswing, cam roller 90 rolls off ramp 88R of cam 88 thereby disengaging the plates 80 and 82 and allowing flywheel 16 to freely rotate. The relative positioning of ramp 88R of cam 88 determines when the flywheel 68 is disengaged. Thus, it can be appreciated that a certain amount of extension of the golfer's torso can be achieved by proper positioning of the cam ramp 88R relative to the golfer's backswing.

The present disclosure includes that contained in the appended claims, as well as that of the foregoing description. Although this invention has been described in its preferred form with a certain degree of particularity, it is understood that the present disclosure of the preferred form has been made only by way of example and that numerous changes in the details of construction and the combination and arrangement of parts may be resorted to without departing from the spirit of the invention.

## Claims

1. An exercising and training machine for exercising a person's ability to accelerate a portion of the person's body along a path of motion about an axis of rotation, comprising in combination:
  - energy-storing means, e.g. a flywheel (16);
  - a frame (12;32);
  - bearing means (52) for rotatably connecting said energy-storing means (16) relative to said frame (12);
  - a harness assembly (20), e.g. a torso harness assembly, for connection to a portion, e.g. the torso, of the person's body to be exercised; characterised by
    - means (68) for interconnecting said energy-storing means (16) and said harness assembly (20) and effective to allow the former (16) rigidly to engage relative to said harness assembly (20) upon acceleration of said harness assembly (20) relative to said energy-storing means (16) in a first direction along the path of motion of the body portion being

exercised and to disengage and freely rotate relative to said harness assembly (20) upon deceleration of said harness assembly (20) relative to said energy-storing means (16).

2. The exercising and training machine as set forth in claim 1, characterised in that said interconnecting means (68) comprises an over-running clutch having an outer race (680) connected to said energy-storing means (16) and having an inner race (681) connected relative to said harness assembly (20); and in that said hearing means (52) preferably comprises a journal bearing (52) mounted to said frame (12, 32) through which a shaft (18) is rotatably journaled.

3. The exercising and training machine as set forth in Claim 2, characterised in that said interconnecting means (68) further comprises a universal joint (22), preferably a constant velocity universal joint, interconnecting said shaft (18) and said harness assembly (20).

4. The exercising and training machine as set forth in Claim 2 or 3, characterised in that said journal bearing (52) comprises means (51, 52B, 54) for reciprocatably connecting said shaft (18) relative to said frame (12, 32) and wherein said inner race (681) of said over-running clutch (68) comprises means (72) for mounting said shaft (18) therethrough so that said shaft (18) may reciprocate relative to said frame (12, 32) and said energy-storing means (16).

5. The exercising and training machine as set forth in Claim 4, characterised in that a spring-loaded stop (56, 60) is connected to said shaft (18) to prevent said shaft (18) from sliding out of said journal bearing (52) and said inner race (681) of said over-running clutch (68) when the exercising and training machine is utilized with said shaft (18) positioned vertically and said harness assembly (20) depending therebelow.

6. The exercising and training machine as set forth in any of Claims 2 to 5 characterised in that a cammed clutch (78) is interconnecting energy-storing means (16) and said shaft (18) to allow the former rigidly to engage said shaft (18) during a predefined arc of rotation of said shaft (18) in a second direction opposite to said first direction; and further characterised in that said cammed clutch (78) may expediently comprise

a first clutch plate (80);

means (52LB) for non-rotatably, reciprocatably mounting said first clutch plate (80) to said shaft (18);

a second clutch plate (82);

means (84) for rigidly connecting said second clutch plate (82) relative to energy-storing means

(16);

a cam roller (90) rotatably mounted relative to said frame; and

a cam (88) mounted to said first clutch plate (80) for engagement by said cam roller (90) during said predefined arc of rotation,

whereby said first clutch plate (80) is cammed into frictional engagement with said second clutch plate (82) when said cam roller (90) engages said cam (88) thereby interconnecting said shaft (18) and said energy-storing means (16) during said predefined arc of rotation; and also characterised in that, optionally, a wearable clutch (86) is positioned between said first clutch plate (80) and said second clutch plate (82).

7. The exercising and training machine as set forth in any of Claims 2 to 6, characterised in that said shaft (18) is positioned vertically relative to said frame (12) with said harness assembly (20) depending therebelow and wherein said frame (12, 32) is adjustably elevated by means of a stand (14), thereby allowing adjustment of the height of said harness assembly (20); and further characterised in that, optionally, said frame comprises a carriaged frame (12) horizontally and reciprocatably mounted relative to said stand (14) allowing said carriaged frame (12) to reciprocate horizontally.

8. The exercising and training machine as set forth in any preceding Claim, characterised in that said harness assembly (20) includes an inverted substantially V-shaped configuration for fitting over the shoulders and onto the upper torso of a person's body.

9. The exercising and training machine as set forth in Claim 7, characterised in that further including means (53) for moving said carriaged frame (12) sideways as said shaft (18) is rotated.

10. The exercising and training machine as set forth in Claim 9, characterised in that said moving means comprises a flexible member (53) connected relative to said shaft (18) and whose trailing ends are rigidly connected to opposing sides (32LS, 32RS) of said upstanding stand (14) such that rotation of said shaft in one direction moves said carriaged frame (12) in one sideways direction and rotation of said shaft (18) in the other direction moves said carriaged frame (12) in the other sideways direction.

#### Patentansprüche

1. Übungs- und Trainingsmaschine zum Üben der Fähigkeit einer Person, einen Körperteil der Person entlang eines Bewegungspfades um eine Drehachse zu bewegen, die in Kombination folgendes aufweist:

- eine Energiespeichereinrichtung, z.B. ein Schwungrad (16);  
einen Rahmen (12; 32);  
eine Lagereinrichtung (52) zur drehbaren Verbindung der Energiespeichereinrichtung (16) mit dem Rahmen (12);  
eine Geschirranordnung (20), z.B. eine Oberkörpergeschirranordnung zur Verbindung mit einem Körperteil der Person, z.B. dem Oberkörper, der trainiert werden soll; gekennzeichnet durch  
eine Einrichtung (68) zur Verbindung der Energiespeichereinrichtung (16) und der Geschirranordnung (20), die derart wirksam ist, daß erstere (16) bei Beschleunigung der Geschirranordnung (20) bezüglich der Energiespeichereinrichtung (16) in einer ersten Richtung entlang des Bewegungspfad des zu trainierenden Körperteils bezüglich der Geschirranordnung (20) starr in Eingriff gelangen und bei Verzögerung der Geschirranordnung (20) bezüglich der Energiespeichereinrichtung (16) bezüglich der Geschirranordnung (20) außer Eingriff gelangen und sich frei drehen kann.
2. Übungs- und Trainingsmaschine nach Anspruch 1, dadurch gekennzeichnet, daß die Verbindungseinrichtung (68) eine Freilaufkupplung mit einem äußeren Laufring (680), der mit der Energiespeichereinrichtung (16) verbunden ist, sowie einem inneren Laufring (681) aufweist, der mit der Geschirranordnung (20) verbunden ist, und daß die Lagereinrichtung (52) bevorzugt ein an dem Rahmen (12, 32) angebrachtes Zapfenlager aufweist, über das eine Welle (18) drehbar über Zapfen gelagert ist.
3. Übungs- und Trainingsmaschine nach Anspruch 2, dadurch gekennzeichnet, daß die Verbindungseinrichtung (68) ferner ein Universalgelenk (22) und bevorzugt ein Doppeluniversalgelenk aufweist, das die Welle (18) und die Geschirranordnung (20) miteinander verbindet.
4. Übungs- und Trainingsmaschine nach Anspruch 2 oder 3, dadurch gekennzeichnet, daß das Zapfenlager (52) Mittel (51, 52B, 54) zur hin- und herbewegbaren Verbindung der Welle (18) bezüglich des Rahmens (12, 32) aufweist, wobei der innere Laufring (681) der Freilaufkupplung (68) eine Einrichtung (72) zum Anbringen der Welle (18) aufweist, so daß sich die Welle (18) bezüglich des Rahmens (12, 32) und der Energiespeichereinrichtung (16) hin- und herbewegen kann.
5. Übungs- und Trainingsmaschine nach Anspruch 4, dadurch gekennzeichnet, daß ein federbelasteter Anschlag (56, 60) mit der Welle (18) verbunden ist, um zu verhindern, daß die Welle (18) aus dem Zapfenlager (52) und dem inneren Laufring (681) der Freilaufkupplung (68) gleitet, wenn die Übungs- und Trainingsmaschine mit vertikal positionierter Welle (18) und herabhängender Geschirranordnung (20) verwendet wird.
6. Übungs- und Trainingsmaschine nach einem der Ansprüche 2 bis 5, dadurch gekennzeichnet, daß eine Nockenkupplung (78) die Energiespeichereinrichtung (16) und die Welle (18) verbindet, um es ersterer zu ermöglichen, während eines vordefinierten Drehbogens der Welle (18) starr an der Welle (18) in einer zweiten, der ersten Richtung entgegengesetzten Richtung einzugreifen; ferner dadurch gekennzeichnet, daß die Nockenkupplung (78) zweckmäßig  
eine erste Kupplungsplatte (80) aufweisen kann;  
eine Einrichtung (52LB) zum nicht drehbaren, hin- und herbewegbaren Anbringen der ersten Kupplungsplatte (80) an der Welle (18);  
eine zweite Kupplungsplatte (82);  
eine Einrichtung (84) zum starren Verbinden der zweiten Kupplungsplatte (82) bezüglich der Energiespeichereinrichtung (16);  
eine Kurvenrolle (90), die bezüglich des Rahmens drehbar gelagert ist; sowie  
eine Kurvenscheibe (88), die an der ersten Kupplungsplatte (80) zum Eingriff durch die Kurvenrolle (90) während des vordefinierten Drehbogens angebracht ist,  
wodurch die erste Kupplungsplatte (80) in kraftschlüssigem Nockeneingriff mit der zweiten Kupplungsplatte (82) steht, wenn die Kurvenrolle (90) an der Kurvenscheibe (88) eingreift, wodurch die Welle (18) und die Energiespeichereinrichtung (16) während des vordefinierten Drehbogens miteinander verbunden sind; und auch dadurch gekennzeichnet, daß zwischen der ersten Kupplungsplatte (80) und der zweiten Kupplungsplatte (82) eine verschleißbare Kupplung (86) angeordnet ist.
7. Übungs- und Trainingsmaschine nach einem der Ansprüche 2 bis 6, dadurch gekennzeichnet, daß die Welle (18) bezüglich des Rahmens (12) vertikal positioniert ist, wobei die Geschirranordnung (20) herunterhängt, und wobei der Rahmen (12, 32) mittels eines Gestells (14) verstellbar angehoben ist, wodurch die Höhenverstellung der Geschirranordnung (20) ermöglicht wird; ferner dadurch gekennzeichnet, daß der Rahmen wahlweise einen Schlittenrahmen (12) aufweist, der bezüglich des Gestells (14) horizontal und hin- und herbewegbar angebracht ist, womit es dem Schlittenrahmen (12) ermöglicht wird, sich horizontal hin- und herzubewegen.
8. Übungs- und Trainingsmaschine nach einem der vorhergehenden Ansprüche, dadurch gekennzeichnet, daß die Geschirranordnung (20) eine im

wesentlichen V-förmige, umgedrehte Ausgestaltung umfaßt, so daß sie über die Schultern und auf den Oberteil des Körpers einer Person paßt.

9. Übungs- und Trainingsmaschine nach Anspruch 7, dadurch gekennzeichnet, daß sie ferner eine Einrichtung (53) zum seitlichen Bewegen des Schlittenrahmens (12) umfaßt, wenn die Welle (18) gedreht wird. 5
10. Übungs- und Trainingsmaschine nach Anspruch 9, dadurch gekennzeichnet, daß die Bewegungseinrichtung ein flexibles Element (53) aufweist, das mit der Welle (18) verbunden ist, und dessen Hinterenden mit entgegengesetzten Seiten (32LS, 32RS) des stehenden Gestells (14) derart verbunden sind, daß die Drehung der Welle in einer Richtung den Schlittenrahmen (12) in einer seitlichen Richtung und die Drehung der Welle (18) in der anderen Richtung den Schlittenrahmen (12) in der anderen seitlichen Richtung bewegt. 10 15 20

### Revendications

1. Appareil d'entraînement et d'exercice pour exercer la capacité d'une personne à accélérer une partie de son corps le long d'un trajet de mouvement autour d'un axe de rotation, comprenant en combinaison : 25
- des moyens de stockage d'énergie, par exemple un volant moteur (16) ; 30
  - un bâti (12 ; 32) ;
  - des moyens formant palier (52) pour connecter en rotation lesdits moyens de stockage d'énergie (16) par rapport audit bâti (12) ; 35
  - un ensemble formant harnais (20), par exemple un ensemble formant harnais de tronc, pour la connexion à une partie, par exemple le tronc, du corps de la personne s'exerçant, 40
  - caractérisé par
  - des moyens (68) pour interconnecter lesdits moyens de stockage d'énergie (16) et ledit ensemble formant harnais (20) et qui sont efficaces à permettre aux premiers (16) de venir en prise rigide par rapport audit ensemble formant harnais (20) lors de l'accélération dudit ensemble formant harnais (20) par rapport auxdits moyens de stockage d'énergie (16) dans une première direction le long du trajet de mouvement de la partie du corps en cours d'exercice et à sortir de prise et tourner librement par rapport audit ensemble formant harnais (20) lors de la décélération dudit ensemble formant harnais (20) par rapport auxdits moyens de stockage d'énergie (16). 45 50
2. Appareil d'entraînement et d'exercice selon la revendication 1, caractérisé en ce que lesdits moyens d'interconnexion (68) comprennent un embrayage à roue libre ayant une piste extérieure (68θ) connectée auxdits moyens de stockage d'énergie (16) et 55
- une piste intérieure (68l) connectée par rapport audit ensemble formant harnais (20) ; et en ce que lesdits moyens formant palier (52) comprennent de préférence un palier d'appui (52) monté sur ledit bâti (12 ; 32) au travers duquel un arbre (18) est supporté en rotation.
3. Appareil d'entraînement et d'exercice selon la revendication 2, caractérisé en ce que lesdits moyens d'interconnexion (68) comprennent en outre une articulation universelle (22), de préférence une articulation universelle à vitesse constante, interconnectant ledit arbre (18) et ledit ensemble formant harnais (20). 10
4. Appareil d'entraînement et d'exercice selon la revendication 2 ou 3, caractérisé en ce que ledit palier d'appui (52) comprend des moyens (51, 52B, 54) pour connecter ledit arbre (18) par rapport audit bâti (12 ; 32) en autorisant un mouvement alternatif et en ce que ladite piste intérieure (68l) dudit embrayage à roue libre (68) comprend des moyens (72) pour monter ledit arbre (18) au travers de celui-ci de telle sorte que ledit arbre (18) peut avoir un mouvement alternatif par rapport audit bâti (12 ; 32) et auxdits moyens de stockage d'énergie (16). 15
5. Appareil d'entraînement et d'exercice selon la revendication 4, caractérisé en ce qu'une butée (56, 60) sollicitée par un ressort est connectée audit arbre (18) pour empêcher ledit arbre (18) de glisser hors dudit palier d'appui (52) et de ladite piste intérieure (68l) dudit embrayage à roue libre (68) lorsque que l'appareil d'entraînement et d'exercice est utilisé avec ledit arbre (18) positionné verticalement et que ledit ensemble formant harnais (20) en dépend par en-dessous. 20
6. Appareil d'entraînement et d'exercice selon l'une quelconque des revendications 2 à 5, caractérisé en ce qu'un embrayage à came (78) interconnecte lesdits moyens de stockage d'énergie (16) et ledit arbre (18) pour permettre au premiers de venir en prise rigide avec ledit arbre (18) pendant un arc prédéfini de rotation dudit arbre (18) dans une seconde direction opposée à ladite première direction ; et en ce que ledit embrayage à came (78) peut commodément comprendre 25
- un premier plateau d'embrayage (80) ;
  - des moyens (52LB) pour monter, de façon non rotative, mais en permettant un mouvement alternatif, ledit premier plateau (80) sur ledit arbre (18) ;
  - un second plateau d'embrayage (82) ;
  - des moyens (84) pour connecter rigidement ledit second plateau d'embrayage (82) par rapport auxdits moyens de stockage d'énergie (16) ;
  - un galet suiveur de came (90) monté rotatif par rapport audit bâti ; et 30 35 40 45 50 55

une came (88) montée sur ledit premier plateau d'embrayage (80) pour recevoir le contact dudit galet suiveur de came (90) pendant ledit arc prédéfini de rotation,

grâce à quoi ledit premier plateau d'embrayage (80) est amené en prise par friction, sous l'effet de la came, avec ledit second plateau d'embrayage (82) lorsque ledit galet suiveur de came (90) vient en contact avec ladite came (88), connectant ainsi ledit arbre (18) et lesdits moyens de stockage d'énergie (16) pendant ledit arc de rotation prédéfini ; et en ce que, éventuellement, un embrayage d'usure (86) est positionné entre ledit premier plateau d'embrayage (80) et ledit second plateau d'embrayage (82).

7. Appareil d'entraînement et d'exercice selon l'une quelconque des revendications 2 à 6, caractérisé en ce que ledit arbre (18) est positionné verticalement par rapport audit bâti (12 ; 32) avec ledit ensemble formant harnais (20) en dépendant par en-dessous, en ce que ledit bâti (12 ; 32) est réglé en hauteur au moyen d'un socle (14), permettant ainsi le réglage de la hauteur dudit ensemble formant harnais (20) ; et en ce que, éventuellement, ledit bâti (12 ; 32) comprend un bâti (12) sur chariot monté horizontalement et adapté à un mouvement alternatif par rapport audit socle (14) permettant audit bâti (12) sur chariot d'avoir un mouvement alternatif horizontal.
8. Appareil d'entraînement et d'exercice selon l'une quelconque des revendications précédentes, caractérisé en ce que ledit ensemble formant harnais (20) comprend une configuration sensiblement en V inversé pour s'adapter aux épaules et au torse de la personne.
9. Appareil d'entraînement et d'exercice selon la revendication 7, caractérisé en ce qu'il comporte en outre des moyens (53) pour déplacer le bâti (12) sur chariot latéralement lorsque ledit arbre (18) tourne.
10. Appareil d'entraînement et d'exercice selon la revendication 9, caractérisé en ce que ledit moyen de déplacement comprend un élément flexible (53) connecté par rapport audit arbre (18) et dont les extrémités de fuite sont connectées rigidement aux côtés opposés (32LS, 32RS) dudit socle vertical (14), de telle sorte que la rotation dudit arbre dans une direction déplace ledit bâti (12) sur chariot dans une direction latérale, et que la rotation dudit arbre (18) dans l'autre direction déplace ledit bâti (12) sur chariot dans l'autre direction latérale.



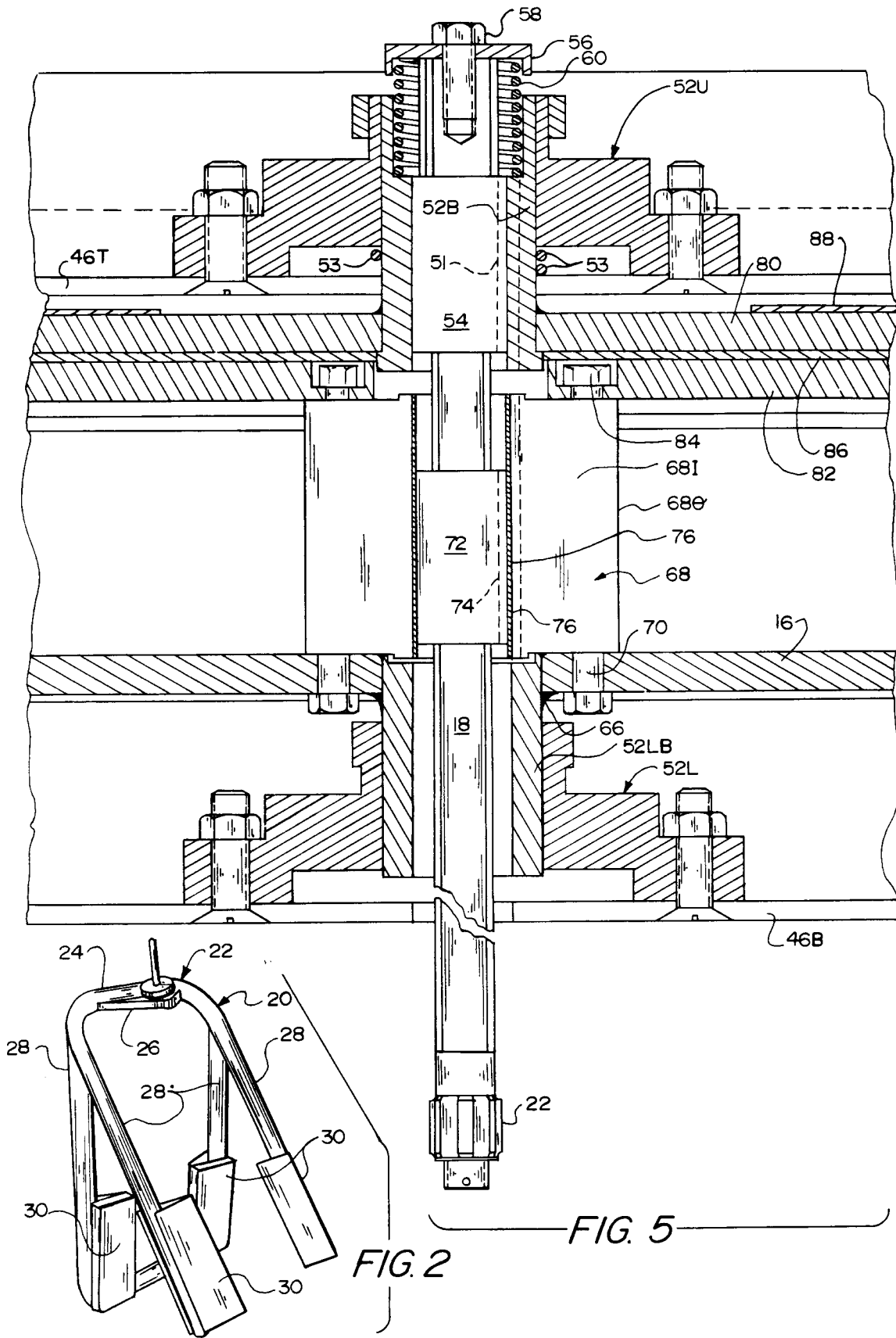
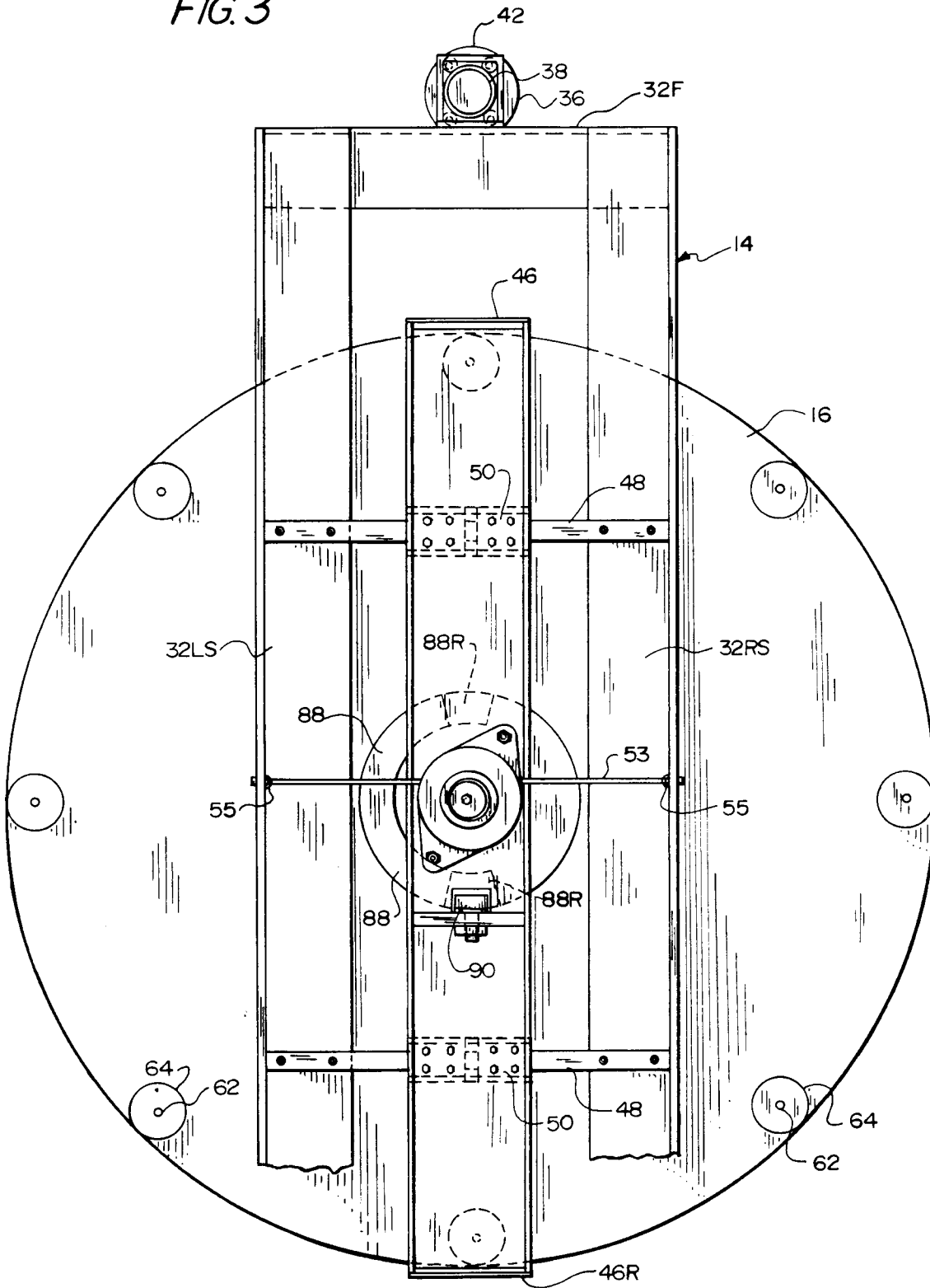

FIG. 3



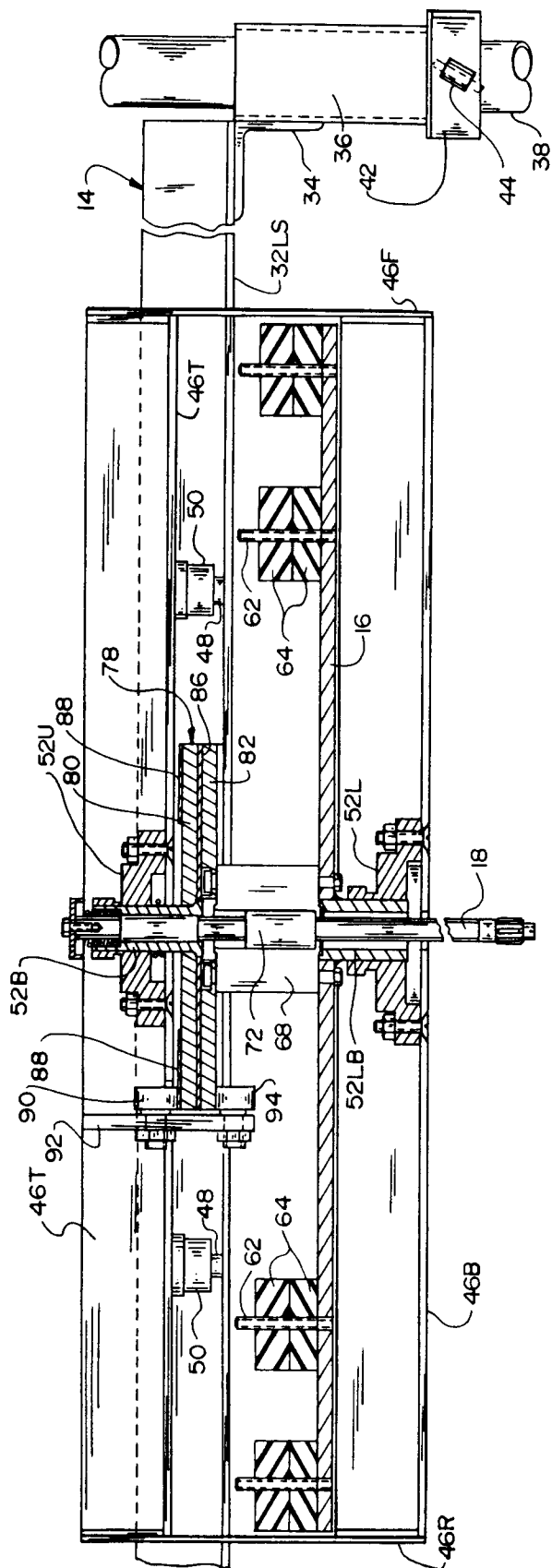

FIG. 4