



Europäisches Patentamt
European Patent Office
Office européen des brevets



Publication number:

0 418 784 A2

12

EUROPEAN PATENT APPLICATION

21 Application number: **90117866.5**

51 Int. Cl.⁵: **H01J 61/40**

22 Date of filing: **17.09.90**

30 Priority: **20.09.89 JP 241993/89**

43 Date of publication of application:
27.03.91 Bulletin 91/13

64 Designated Contracting States:
DE GB NL

71 Applicant: **HITACHI, LTD.**
6, Kanda Surugadai 4-chome
Chiyoda-ku, Tokyo 101(JP)

72 Inventor: **Miyashita, Tsune**
2196-608 Hirai, Hinode-machi

Nishitama-gun, Tokyo 190-01(JP)
Inventor: **Kodama, Masayoshi**
2196-292 Hirai, Hinode-machi
Nishitama-gun, Tokyo 190-01(JP)
Inventor: **Hatakeyama, Atsushi**
Keishin-Ryo, 888 Fujihashi
Ome-shi, Tokyo 198(JP)

74 Representative: **Strehl, Schübel-Hopf,**
Groening
Maximilianstrasse 54 Postfach 22 14 55
W-8000 München 22(DE)

54 Lamp provided with thin film for reflecting infrared rays.

57 A lamp is provided on the surface of its glass bulb with a multi-layer film comprising an alternate laminate of at least one dielectric layer (8) of a higher refractive index and at least one dielectric layer (9) of a lower refractive index, so as to transmit visible rays radiated from a light source (1) and to reflect infrared rays radiated from the light source (1), wherein a low transmittance range with a transmittance of 10 to 40% is provided in a visible region.

FIG. 1

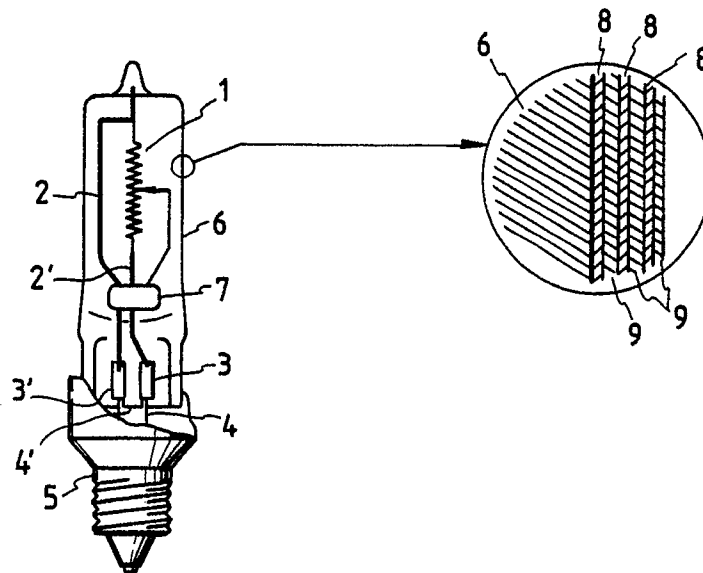

EP 0 418 784 A2

LAMP PROVIDED WITH THIN FILM FOR REFLECTING INFRARED RAYS

BACKGROUND OF THE INVENTION

This invention relates to a tungsten-halogen lamp comprising on the outer surface of a bulb a multi-layer dielectric film for transmitting visible rays and reflecting infrared rays or an HID [High Intensity
5 Discharge) lamp such as a metal halide lamp comprising a similar multi-layer dielectric film on the outer surface of an inner bulb, and more particularly to means for modifying the light-source color in such a lamp.

Provision of a transparent multi-layer dielectric film on a tungsten-halogen lamp so as to reflect infrared rays thereby improving the luminous efficacy of the lamp is disclosed in, for example, Japanese Patent Application Laid-Open (KOKAI) No. 57-119454 (1982) or Japanese Patent Publication No. 1-14258 (1989).
10 With respect to the thickness of the dielectric film in such instances, a description is given in, for example, Japanese Patent Application Laid-Open (KOKAI) No. 61-190853 (1986). Furthermore, it is also known to provide the multi-layer dielectric film with a regulated transmittance of rays in the visible region so as to cause the visible radiation from the lamp to have a yellow color, as for instance described in Japanese Utility Model Application Laid-Open (KOKAI) No. 1-86102 (1989). A description of a reflector comprising a
15 multi-layer dielectric film is made in, for example, Y. Yuge, "Review of Optical Coatings for Incandescent and Other Lamps", 5th International Symposium on the Science & Technology of Light Sources, York-England, 10-14 September, 1989.

Though the above-mentioned prior arts are free of any problems or difficulties in providing a multi-layer dielectric film on the surface of a lamp bulb as an infrared ray reflector film, the prior arts have yet been
20 unsatisfactory in achieving a modification of the light-source color of a lamp easily and with high luminous efficacy.

SUMMARY OF THE INVENTION

25 It is accordingly an object of this invention to provide a lamp which achieves a modification of the light-source color of the lamp easily and with high luminous efficacy, by improving the above-mentioned infrared ray reflector film.

The above object is attained by a lamp according to this invention in which the optical thickness of some
30 of the layers in a multi-layer dielectric film provided on the surface of a lamp bulb is different from that of the other layers, whereby interference is generated between the layers to produce a reflection range over a narrow wavelength range in the visible region, resulting in a change in the light-source color of the lamp.

It is thus possible, according to this invention, to alter the light-source color without increasing the number of layers in the multi-layer dielectric film baked on the surface of a silica glass bulb of a tungsten-halogen lamp or HID lamp. It is also possible, according to the invention, to minimize the lowering in the
35 luminous efficacy of the lamp associated with the alteration of the light-source color. In addition, the alteration of the light-source color is achieved by simply changing the thickness of film of a dielectric material, and it is therefore possible to produce the lamp easily.

The above and other objects, features and advantages of this invention will become apparent from the
40 following description and appended claims, taken in conjunction with the accompanying drawings which show by way of example some preferred embodiments of the invention

BRIEF DESCRIPTION OF THE DRAWINGS

45 Figure 1 is an illustration of a tungsten-halogen lamp according to this invention;
Figure 2 is an illustration of an HID lamp according to this invention;
Figure 3 is a characteristic diagram showing the reflectance of a multi-layer dielectric film according to this invention; and
50 Figure 4 is a characteristic diagram showing the reflectance of another multi-layer dielectric film according to this invention.

DESCRIPTION OF THE PREFERRED EMBODIMENTS

First, the principle on which this invention is based will be described below.

A multi-layer dielectric film provided on the surface of a lamp bulb produces an interference between the layers, thereby reflecting infrared rays back to the inside of the lamp. Therefore, the electric input required for heating the lamp is reduced, and energy saving is achieved. It is known that where the peak of reflection of the infrared rays by the multi-layer dielectric film is set in the vicinity of $1 \mu\text{m}$, it is possible to reduce the reflection by the multi-layer dielectric film in the visible region of about 400 to 800 nm to a minimum, so that the radiation of the visible rays from the lamp is not reduced at all, which is favorable. It is further known that optical characteristics with good luminous efficacy are obtainable by setting the optical thickness of most layers in the multi-layer dielectric film equal to $1/4$ times the wavelength and setting the optical thickness of only the uppermost, low-dielectric-constant layer equal to $1/8$ times the wavelength.

A multi-layer dielectric film having a desired reflectance in an arbitrary wavelength range in the visible region may also be provided, separately from the above-mentioned multi-layer dielectric film for reflecting the infrared rays. In that case, it is possible to cause the visible radiation from the lamp to have a desired color. The desired characteristics are not achieved, however, unless the interference between the multi-layer dielectric film for reflecting the infrared rays and the multi-layer dielectric film for reflecting the visible rays is prevented. It is therefore necessary to provide a third layer for eliminating the interference between the two multi-layer dielectric films, with the result of an increase in the number of layers of dielectric film.

With slight deviations of the optical thickness of each layer in the multi-layer dielectric film for reflecting infrared rays, from the optical thickness value of $1/4$ times the wavelength in the regular lamination, it has been possible to enhance the reflectance locally in the visible region, and therefore to alter the light-source color, through the high order interference between the dielectric layers. The reflected light in the visible region is returned to the inside of the lamp, serving as energy for heating the lamp, so that a better luminous efficacy is achieved as compared with the case where the light-source color is altered by providing the lamp with a visible ray absorber. In any case, the transmittance for visible rays is reduced, resulting in a luminous efficacy poorer than that achieved in the case of reducing the reflectance in the visible region. For obtaining a higher luminous efficacy of the lamp, therefore, it is necessary to minimize the wavelength range of reflection in the visible region, namely, the low transmittance range. When the transmittance of the low transmittance range is less than 10%, a sufficient alteration of the light-source color is not achieved. When the transmittance of the low transmittance range is more than 40%, on the other hand, the color relevant to the lowered transmittance is substantially absent in the light emitted from the lamp, which result is undesirable. Besides, when the low transmittance range is so broad as to have a half-width of more than 100 nm, an undesirable lowering in luminous efficacy would result.

Some embodiments of this invention will now be described below while referring to the drawings.

Figure 1 illustrates a tungsten-halogen lamp according to one embodiment of this invention, which comprises a tungsten filament 1, tungsten inner leads 2, 2', molybdenum foils 3, 3', molybdenum outer leads 4, 4', a base 5, a silica glass bulb 6, and beads 7. On the outer surface of the silica glass bulb 6 is baked a multi-layer dielectric film which, as shown in an enlarged view indicated by an arrow comprises an alternate laminate of titanium oxide layers (refractive index: 2.30) 8 and silicon oxide layers (refractive index: 1.45) 9.

Referring to Figure 2, there is shown a metal halide lamp as an HID lamp according to another embodiment of this invention, which comprises inner leads 12, 12', molybdenum foils 13, 13', bases 15, 15', and a silica glass bulb 16 as an inner bulb filled with a metal halide or the like. The bulb 16 is provided with a heat-insulating coating (not shown) on both ends thereof, and a pair of electrodes, not shown, are embedded in the ends of the bulb, in connection with respective molybdenum foils. Denoted by 17 is an outer bulb. Similarly to the tungsten-halogen lamp above, a multi-layer dielectric film comprising an alternate laminate of titanium oxide layers and silicon oxide layers is baked on the outer surface of a central portion of the silica glass bulb 16.

Figure 3 is a diagram showing the spectral reflectance of one example of the multi-layer dielectric film in the lamp shown in Figure 1 or 2. Curves a, b and c in the spectral reflectance diagram were obtained with the respective multi-layer dielectric films, as set forth in the following Table 1, provided on the surface of the lamp bulb. The multi-layer dielectric film comprises a first layer (layer No. 1), a second layer (layer No. 2) and so on, in that order from the side of the silica glass bulb 6 or 16. Optical thickness of film is given in the units of nd/λ_0 , where λ_0 is center of the wavelength, n is refractive index, and d is the thickness of film.

Table 1

Layer No.	Material	Optical thickness of film		
		curve a	curve b	curve c
1	titanium oxide	0.25	0.25	0.25
2	silicon oxide	0.25	0.25	0.25
3	titanium oxide	0.25	0.25	0.25
4	silicon oxide	0.20	0.25	0.30
5	titanium oxide	0.25	1.00	0.25
6	silicon oxide	0.25	0.25	0.25
7	titanium oxide	0.25	0.25	0.25
8	silicon oxide	0.125	0.125	0.125
Center of the wavelength, λ_0 (nm)		1100	970	900

The curve a, where the optical thickness of the fourth layer (layer No. 4) was changed from the predetermined value of 0.25 to a value of 0.20, indicates a weakening of a blue component of the light-source color, thereby producing the effect of increasing the warmth of color. The curve b, where the optical thickness of the fifth layer (layer No. 5) was changed from the predetermined value of 0.25 to a value of 1.00, indicates a weakening of a yellow component of the light-source color, with the resultant effect of rendering body colors more vivid. The curve c, where the optical thickness of the fourth layer (layer No. 4) was changed from the predetermined value of 0.25 to a value of 0.30, indicates a reduction in the quantity of red color in the light source color, thereby producing a refreshing feeling. Though the optical thickness of the fourth layer (layer No. 4) was deviated from the predetermined value in the case of curve a, as shown in Table 1, substantially the same effect was also obtained with a deviation of the optical thickness of the sixth layer (layer No. 6) from the predetermined value. Though the optical thickness of the fourth layer (layer no. 4) was deviated from the predetermined value in the case of curve c, a similar effect was also obtained with a deviation of the optical thickness of the sixth layer (layer No. 6) from the predetermined value; however, the effect thus obtained was lower as compared to the case of curve c.

Figure 4 is a diagram showing the spectral reflectance of another example of the multi-layer dielectric film used in the lamp shown in Figure 1 or 2. In the spectral reflectance diagram, curves a, b and c correspond to the respective multi-layer dielectric films, as set forth in the following Table 2, provided on the surface of the lamp bulb. The multi-layer dielectric film comprises a first layer (layer No. 1), a second layer (layer No. 2) and so on, in that order from the side of the silica glass bulb 6 or 16.

Table 2

Layer No.	Material	Optical thickness of film		
		curve a'	curve b'	curve c'
1	titanium oxide	0.25	0.25	0.25
2	silicon oxide	0.25	0.25	0.25
3	titanium oxide	0.25	0.25	0.25
4	silicon oxide	0.20	0.25	0.30
5	titanium oxide	0.25	1.00	0.25
6	silicon oxide	0.125	0.125	0.125
Center of the wavelength, λ_o (nm)		1100	970	900

Similarly to the cases represented in Figure 3, the followings are seen from Figure 4. The curve a', where the optical thickness of the fourth layer (layer No. 4) was changed from the predetermined value of 0.25 to a value of 0.20, indicates a weakening of a blue component of the light-source color, with the attendant effect of increasing the warmth of color. The curve b', where the optical thickness of the fifth layer (layer No. 5) was changed from the predetermined value of 0.25 to a value of 1.00, indicates a reduction in the quantity of a yellow color in the light-source color, with the resultant effect of rendering body colors more vivid. The curve c', where the optical thickness of the fourth layer (layer No. 4) was changed from the predetermined value of 0.25 to a value of 0.30, indicates a weakening of a red component of the light-source color, with the accompanying effect of producing a refreshing feeling.

Though the description of the embodiments above has been made referring to the cases of providing the multi-layer dielectric film by coating and baking, the same or similar effects can also be expected in the cases of providing the multi-layer dielectric film by vacuum deposition or sputtering or the like.

Claims

1. A lamp comprising an optically transparent bulb (6) enclosing a light-source (1) for radiating light when electric power supplied to it, and having a multi-layer dielectric film provided on the outer surface of the bulb (6) and including an alternate laminate of at least one dielectric layer (8) having a higher refractive index and at least one dielectric layer (9) having a lower refractive index, most of the dielectric layers (8, 9) having a predetermined optical thickness, the multilayer film being able to transmit visible rays and to reflect infrared rays, wherein the optical thickness of a predetermined one of the dielectric layers (8, 9) other than the outermost layer is different from the predetermined optical thickness.

2. A lamp comprising an optically transparent bulb (6) enclosing a light-source (1) for radiating light when electric power supplied to it, and having a multi-layer dielectric film provided on the outer surface of the bulb (6) and including an alternate laminate of at least one dielectric layer (8) having a higher refractive index and at least one dielectric layer (9) having a lower refractive index, most of the dielectric layers (8, 9) having a predetermined optical thickness, the multilayer film being able to transmit visible rays and to reflect infrared rays, wherein the optical thickness of a predetermined one of the dielectric layers (8, 9) other than the outermost layer is selected so as to produce a low transmittance range with a transmittance of 10 to 40% in the visible region.

3. The lamp of claim 2, wherein the half-width of the low transmittance range is not more than 100 nm.

4. The lamp of claim 2 or 3, wherein the low transmittance range is provided in any one of the red, yellow and blue visible regions.

5. The lamp of any one of claims 1 to 4 and being a tungsten-halogen lamp or a metal halide lamp.

FIG. 1

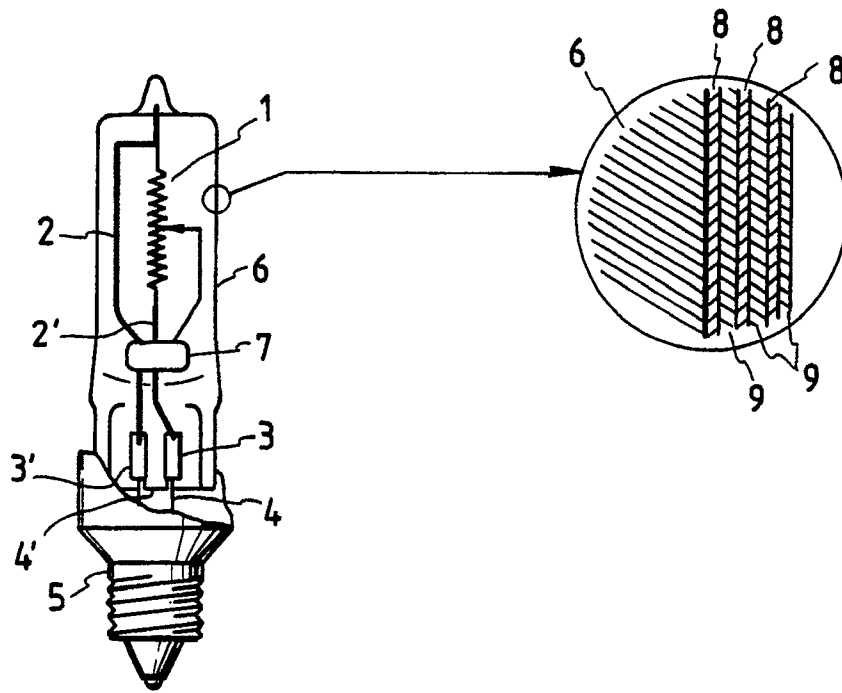

FIG. 2

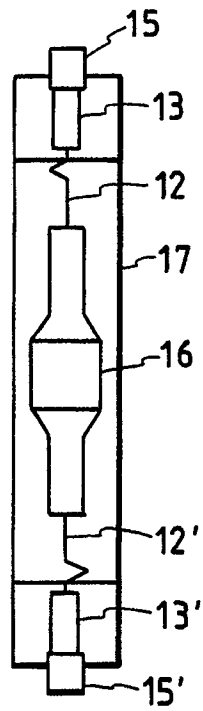

FIG. 3

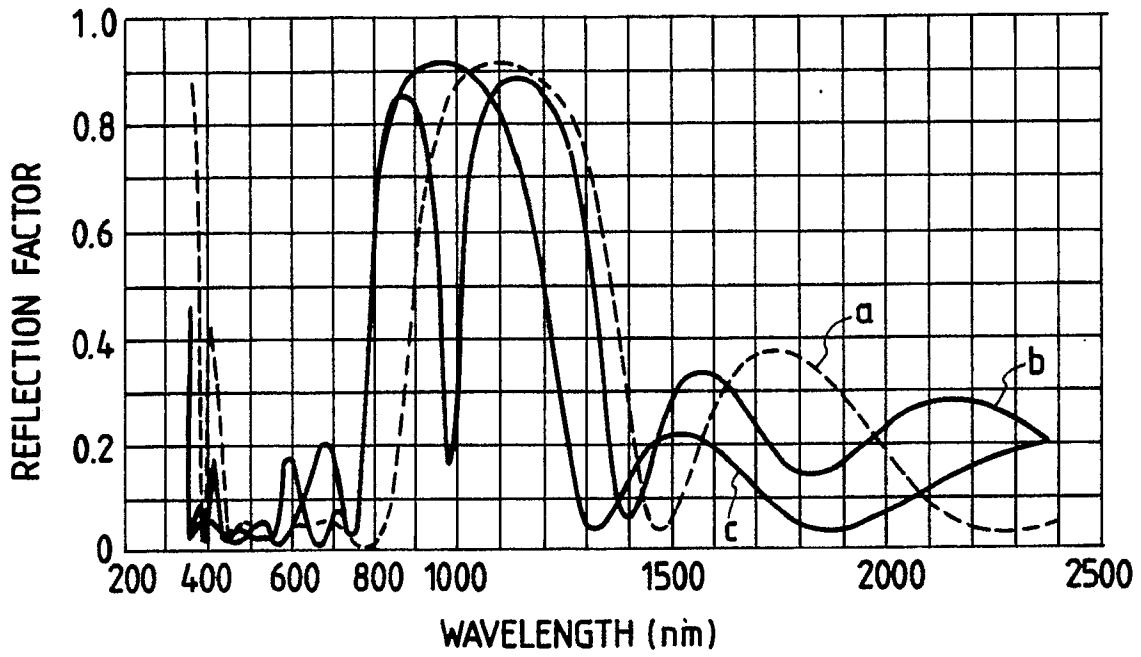

FIG. 4

