



12 **EUROPEAN PATENT APPLICATION**

21 Application number: **91100532.0**

51 Int. Cl.⁵: **H01B 3/18, H01F 27/32**

22 Date of filing: **17.01.91**

30 Priority: **07.02.90 JP 25962/90**

43 Date of publication of application:
14.08.91 Bulletin 91/33

54 Designated Contracting States:
DE FR GB IT SE

71 Applicant: **JAPAN GORE-TEX, INC.**
42-5, 1-chome Akazutsumi
Setagaya-ku Tokyo 156(JP)

72 Inventor: **Hatakeyama, Minoru**
7-1-22, Sakuragaoka-Nishi, Sanyou-Cho
Akaiwa-Gun, Okayama-Ken 709-08(JP)
Inventor: **Sasaki, Fumihiro**
291-5, Yoshinaga-Naka, Yoshinaga-Cho
Wake-Gun, Okayama-Ken 709-02(JP)
Inventor: **Wada, Jinichi**
33-18-306, 1-Chome, Nishioonuma
Sagamihara-Shi, Kanagawa-Ken 229(JP)

74 Representative: **Klunker . Schmitt-Nilson .**
Hirsch
Winzererstrasse 106
W-8000 München 40(DE)

54 **Insulant for oil-filled electrical device.**

57 An insulator for use in oil-filled electrical devices comprising layered together or spaced apart sheets of continuously porous polytetrafluoroethylene or aramide filled with an insulating oil. Higher breakdown voltage is achieved.

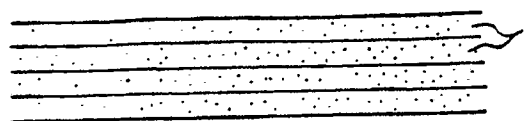

FIG. 1

FIELD OF THE INVENTION

The present invention relates to insulators for use in oil-filled electrical devices such as the transformers used in electrical power generation or for industrial purposes.

BACKGROUND OF THE INVENTION

When the machinery breaks down or the transmission of electrical energy is stopped in transformers, reactors, and other similar oil-filled electrical devices, its effect on the general public is exceedingly great, and if the power outage continues for an extended period of time, there is even the possibility that the people will panic. Accordingly, a high level of reliability is demanded of these oil-filled electrical devices. And because some oil-filled electrical devices handle high voltages, it is of particular importance that the insulators used therein are reliable.

With current insulators composed of pressboard and an insulating oil, when a lightning impulse or other similar impulse voltage has entered the coils of a transformer, a partial discharge occurs between the coils, which breaks the insulation which ultimately can result in damage to the transformer or the like. Because of this, there is a need for the development of a material for insulators used inside an oil-filled electrical device in which the voltage at which partial discharge occurs and the dielectric breakdown voltage is heightened.

An insulator has been proposed which consists of an insulating oil and a pressboard with a low dielectric constant in which polymethylpentene fibers and cellulose fibers have been blended. The dielectric constant of this insulator is 3.5. The dielectric constant of insulators consisting of an insulating oil and conventional pressboard is 4.7. If a comparison of the dielectric breakdown voltage in relation to an impulse voltage is made between the two insulators, the partial discharge commencement voltage and the dielectric breakdown voltage are at least 30% higher when the low-dielectric constant pressboard is used than with the current insulators. Specifically, it is known that the closer is the dielectric constant of the insulator to the dielectric constant of the oil alone (2.2), the more the increase in the above voltage values will be.

Furthermore, copper loss, iron loss, and the like occur in transformers through normal operation, and these factors turn into heat and heat the coils, iron cores, insulating oil, insulators, and other components. Because the deterioration in the pressboard and other paper components is particularly hastened by increases in temperature, transformers which have been in continuous operation for twenty or thirty years undergo a considerable drop in the

insulation strength of their insulators. Thus, there is a problem in that the reliability of the insulators is decreased.

The above discussion is focussed on pressboard, but the same problems hold true for crepe paper and the like as well.

Other types of materials in which it is known to fill the pores of a fluorinated resin with a dielectric fluid for enhancing corona resistance are the insulated electric conductors wherein the insulation is porous polytetrafluoroethylene, as disclosed in U.S. patents 3,150,207 and 3,217,083.

SUMMARY OF THE INVENTION

In order to solve the above problems, the present invention makes use of a composite of a continuously porous fluorinated resin or aramide resin, or one of these and another resin with a low dielectric constant in place of pressboard, crepe paper, draft paper, or the like.

More specifically, the invention is an insulator for use in oil-filled electrical devices, which is characterized by the fact that continuously porous fluorinated resin or aramide resin sheets are used after being impregnated with an insulating oil. Polytetrafluoroethylene (PTFE) fluorinated ethylene propylene copolymer (FEP), perfluoroalkoxy tetrafluoroethylene (PFA), ethylene tetrafluoroethylene copolymers (ETFE), vinylidene fluoride (PVFD), and similar compounds can be utilized for the fluorine resin. Fluorine resins and aramide resins are generally distinguished by low dielectric constants. Using PTFE as an example, the dielectric constant of the PTFE itself is 2.1, and while the dielectric constant of a continuously porous sheet of PTFE which has been impregnated with an insulating oil (dielectric constant of 2.2) will vary depending on the volumetric ratio of the PTFE and the insulating oil, it will be close to the dielectric constant of the insulating oil, and the dielectric breakdown voltage of the insulators will be increased. The dielectric constant of aramide resins is 2.6 to 2.7. Furthermore, PTFE and other fluorinated resins and aramide resins are substances that are extremely stable with respect to chemicals and temperature, with no deterioration attributable to increased temperature, thus allowing insulators to be produced with a high level of reliability that will last for many years. With the range that the strength of the insulator will tolerate, the higher the porosity, the lower and more desirable will be the dielectric constant as a whole, but there are no particular restrictions placed on this.

The invention is an insulator for use in oil-filled electrical devices, which is characterized by the fact that it is composed of a laminate of continuously porous fluorinated resin or aramide resin

layers and resin layers whose dielectric constant is 3.5 or less, wherein said continuously porous fluorinated resin or aramide resin layers are used after being impregnated with an insulating oil. This arrangement is effective when the mechanical strength in the compression direction will not be sufficient with continuously porous fluorinated resin or aramide resin layers alone. The reason for stipulating a dielectric constant of 3.5 or less for the resin is that this is useful when the dielectric strength of the insulators is increased by making the electrostatic focusing smaller and minimizing the difference between the dielectric constant of 2.2 of the insulating oil and the dielectric constant of the insulators. For this purpose, polyimides, polyether ether ketone (PEEK), polyether sulfone (PES), and other similar resins are desirable. Since a given fluorine resin or aramide resin will have a greater mechanical strength in the form of a solid resin layer than as a porous resin layer, the above arrangement can be used to this end. The continuously porous fluorinated resin or aramide resin layers and resin layers whose dielectric constant is 3.5 or less can be alternatively laminated in the required number of layers.

The present invention is an insulator for use in oil-filled electrical devices, which is characterized by the fact that it is composed of continuously porous layers formed by leaving spaces between continuously porous fluorinated resin or aramide resin layers and then packing the spaces with a resin whose dielectric constant is 4.0 or less, wherein an insulating oil is used for impregnation in the continuously porous resin layers. This arrangement is, as above, useful when the compression strength is insufficient and there is a need for the insulation distance to be maintained. The reason for stipulating a dielectric constant of 4.0 or less for the resin to be impregnated is that the resin is compounded with a fluorinated resin with a low dielectric constant and is then impregnated with an insulating oil, which means that the overall dielectric constant is lowered, and the focussing of the electrical field can be made smaller. Ethoxy resins, polyimide resins, bismalidetriazine resins (BT resins), fluorine resins, polyphenylene oxide (PPO) resins, and other similar thermosetting or thermoplastic resins can be used for the above resin, and these may be used singly or in mixtures. By leaving spaces between the resin layers used to pack the pores of the fluorinated resin or between aramide resin layers, an insulating oil can be used to impregnate these spaces. A characteristic of this arrangement is that the porosity of the continuously porous fluorinated resin or aramide resin layers, the amount and type of resin used to pack the fluorinated resin or aramide resin layers, and the final porosity after the resin packing can be ad-

justed depending on the dielectric constant and the mechanical strength required of the insulators, and are not set at fixed values.

The present invention is an insulator for use in oil-filled electrical devices, which are characterized by the fact that they are formed from solid layers in which continuously porous fluorinated resin or aramide resin layers are completely packed with a resin whose dielectric constant is 4.0 or less. Moreover, the handling characteristics of the insulators in this case are enhanced.

In the above, the continuously porous fluorinated resin or aramide resin sheets or layers include continuously porous moldings of extruded or drawn sheets, non-woven cloth, fibrous cloth, yarn cloth, and other fluorinated resin or aramide resin products having continuous pores.

BRIEF DESCRIPTION OF THE DRAWINGS

Figures 1-5 are cross-sectional diagrams of insulators of the examples.

Figure 6 is a structural diagram of a transformer as an oil-filled electrical device.

Figure 7 is a detailed section of coil windings within the transformer of Figure 6.

Figure 8 is a detailed section of the coil of the example.

DETAILED DESCRIPTION OF THE INVENTION

The invention is now described with reference to the figures to more clearly delineate the invention.

EXAMPLE 1

As is shown in Figure 1, an insulator sheet was produced by bundling four sheets of the porous PTFE sheet 1, which had a thickness of 1.6 mm and a porosity of 30%. This insulator sheet was used as the insulator between the coils, as shown in Figure 6, and was put in an insulating oil such as mineral oil, dielectric constant 2.2. Upon examining the dielectric breakdown voltage due to an impulse voltage, it was found to be 330 kv. The dielectric constant of the insulator sheet in an insulating oil-impregnated state was 2.15.

The same type of insulator sheet as that above was then produced in a thickness of 6.4 mm from conventional pressboard, and upon measuring the dielectric breakdown voltage in the same manner as above, it was found to be 200 kv. The dielectric constant was 4.7.

EXAMPLE 2

Upon subjecting to the same test as in Exam-

ple 1 an insulator sheet with a thickness of 6.4 mm and in which, as is shown in Figure 2, the porous PTFE sheet 1, which had a thickness of 1.6 mm and a porosity of 30%, and the solid PTFE sheets 2 (0.8 mm thick) were alternately layered, the dielectric constant was found to be 2.14, and the dielectric breakdown voltage had been increased to nearly the same 330 kv as in Example 1.

It was found that the deformation of the insulators due to the tightening force in the compression direction of the coils was lower than in Example 1.

EXAMPLE 3

Upon subjecting to the same test as in Example 1 an insulator sheet with a thickness of 6.4 mm and in which, as is shown in Figure 3, the porous PTFE sheets 1, which had a thickness of 1.6 mm and a porosity of 30%, and the polyimide sheets 3 (0.8 mm thick) were alternately layered, the dielectric constant was found to be 3.2, and the dielectric breakdown voltage had been increased to 300 kv. It was found that the deformation of the insulators due to the tightening force in the compression direction of the coils was lower than in Examples 1 and 2.

EXAMPLE 4

As is shown in Figure 4, porous PTFE sheet 1, which had a thickness of 0.25 mm and a porosity of 80%, was 30% impregnated with polyimide resin 4 (dielectric constant of 3.1), and was compressed to 0.2 mm with a hot press and the polyimide resin hardened (in Figure 4, 5 is the spaces). This product was used as an insulating sheet, and 32 of these insulating sheets were bundled together to form an insulator sheet with a thickness of 6.4 mm. Upon subjecting this sheet to the same test as in Example 1, the dielectric constant was found to be 2.4 and the dielectric breakdown voltage had been increased to nearly 320 kv.

Also, it was found that the mechanical strength in the compression direction had been increased significantly, and that the deformation of the insulators due to the tightening force was extremely low.

EXAMPLE 5

Porous PTFE sheet 1, which had a thickness of 0.3 mm and a porosity of 80%, was impregnated with epoxy resin 6 (dielectric constant of 2.6) and was then compressed to 0.2 mm with a hot press and the epoxy resin hardened. This product was used as an insulating sheet, and 32 of these insulating sheets were bundled together to form an insulator with a thickness of 6.4 mm. Upon subjecting this insulator to the same test as in Example 1,

the dielectric constant was found to be 2.4, and the dielectric breakdown voltage due to impulse voltage was 320 kv, nearly the same as in Example 4.

Also, it was found that the mechanical strength in the compression direction was greatest and that the deformation of the insulators was extremely low.

EXAMPLE 6

An aramide non-woven cloth was 30% impregnated with an epoxy resin (dielectric constant of 2.6), and was then hardened in a constant temperature tank. Several of these products were layered to form an insulator thickness of 6.4 mm. Upon subjecting this to the same test as in Example 1, the dielectric constant was found to be 2.4 and the dielectric breakdown voltage due to impulse voltage had been increased to nearly 320 kv.

Also, it was found that the compression and tensile mechanical strengths were greater than with the fluorinated resin.

Figure 6 shows a transformer as an example of oil-filled electrical devices. In this figure, coils, in which the windings 14 are wound around the iron cores 13, are immersed in the insulating oil of the transformer tank 11, and are connected to the bushing 16 via the lead wire 15. A soundproofing tank is denoted as 16 and a cooling device as 17. Figure 7 shows a detail of the coils, wherein the windings 14 are constructed such that insulation 22 is wound around the straight angle copper wires 21, and an insulator 23 is interposed between the individual windings to insulate them. There are also the rails 24 and the insulated tube 25, among other components. Specifically, the principal insulator of tie oil-filled electrical device is a continuously porous PTFE or aramide resin of layers which is impregnated with an insulating oil such as mineral oil.

In Figure 8 is shown a structure in which the windings 31 (straight angle copper wires wound with insulation) are bundled with the insulators 32, and if needed, the solid layers 33 interposed between these insulators. In addition to being used in place of pressboard and crepe paper around the windings 31, the insulators of the present invention can also be used as these insulators 32. In other words, they can be used for any of the insulators in an oil-filled electrical device.

The porous PTFE utilized in the invention may be the porous expanded PTFE described in U.S. Patent Nos. 3,953,566, 3,962,153, 4,096,227, 4,187,390, 4,902,423, or 4,478,665, or may be made by other methods of stretching or by extracting a soluble material from a filled PTFE or aramide resin by a suitable solvent. An aramide resin may also be made porous by dissolving it in sol-

vent, molding the solution, then removing the solvent. Other fluorinated resins than PTFE can be made porous by use of a foaming agent or an extraction process, such as that above.

Because the dielectric constant of continuously porous fluorinated resin or aramide resin sheets or layers is less than that of pressboard, crepe paper, or the like, the dielectric constant of the overall insulators impregnated with insulating oil will also be reduced. Also, the mechanical strength can be increased by laminating a solid resin layer with continuously porous fluorinated resin or aramide resin layers or by packing the pores with another resin. By limiting the dielectric constant of these resins to a specific value or less, the dielectric constant of the insulators as a whole will be lower than conventional insulators made of pressboard or the like. Further, fluorinated resins and aramide resins are chemically and thermally stable, making them excellent insulators.

Claims

1. An insulator for use in oil-filled electrical devices comprising layers of continuously porous fluorinated resin or aramide resin sheets impregnated with an insulating oil.
2. An insulator of Claim 1, wherein said layers have a dielectric constant of 3.5 or less when impregnated with an insulating oil.
3. An insulator of Claim 2, wherein said layers are solid fluorinated resin layers.
4. An insulator of Claim 1, wherein said continuously porous layers are spaced apart, said space filled with a resin whose dielectric constant is 4.0 or less, and said continuously porous layers impregnated with an insulating oil.
5. An insulator of Claim 3, wherein solid layers of continuously porous fluorinated resin or aramide resin are completely packed with a resin whose dielectric constant is 4.0 or less.
6. An insulator according to at least one of the claims 1 to 5, wherein said continuously porous fluorinated or aramide resin sheets comprise porous moldings, non-woven cloth, fibrous cloth, or yarn cloth.

55

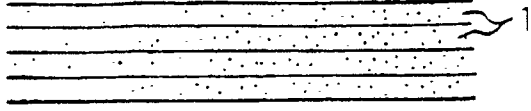

FIG. 1

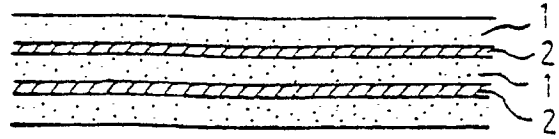

FIG. 2

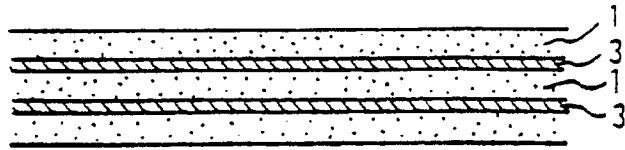

FIG. 3

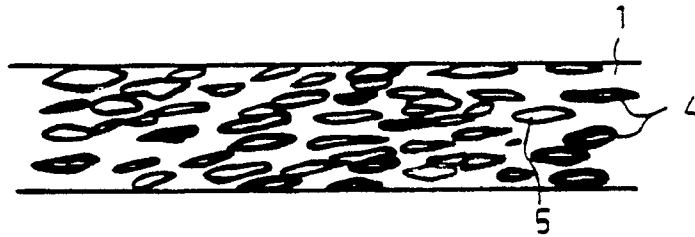

FIG. 4

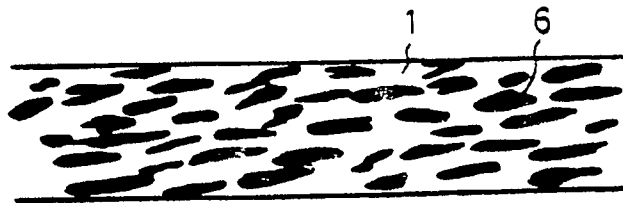

FIG. 5

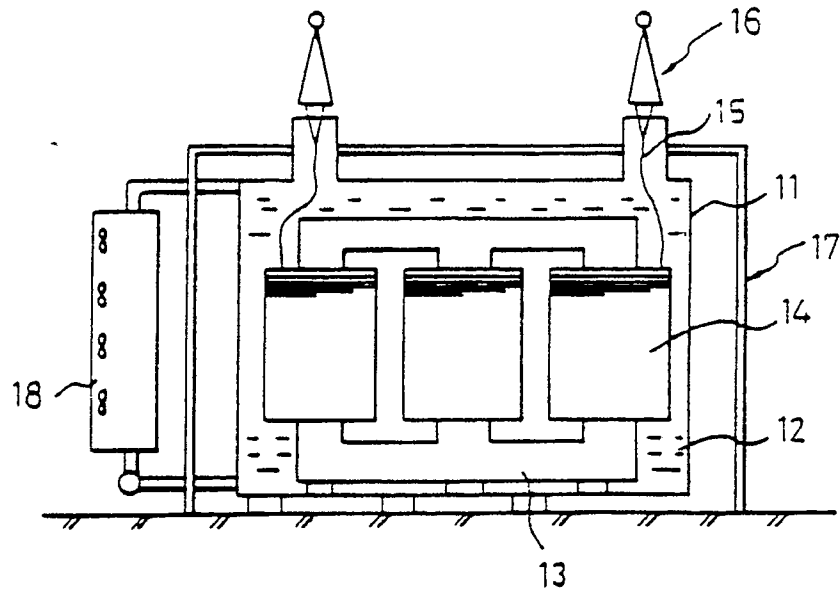

FIG. 6

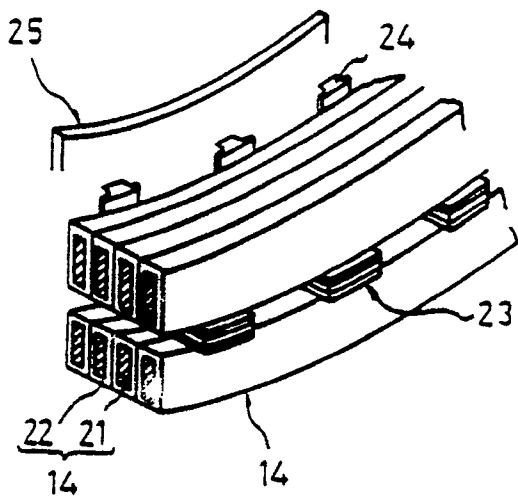

FIG. 7

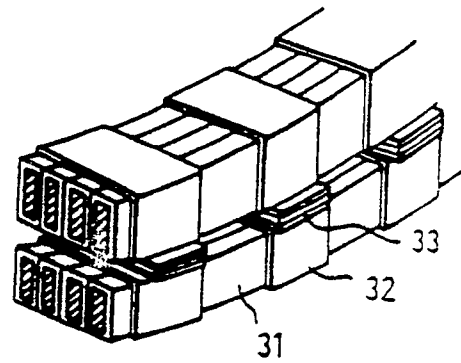

FIG. 8



EP 91100532.0

DOCUMENTS CONSIDERED TO BE RELEVANT			EP 91100532.0
Category	Citation of document with indication, where appropriate, of relevant passages	Relevant to claim	CLASSIFICATION OF THE APPLICATION (Int. Cl.5)
X;Y	<u>DE - B2 - 2 815 451</u> (MITSUBISHI) * Column 1, lines 25-31; column 2, line 52 - column 3, line 8; example 1 * --	1,2,6; 1,2,6	H 01 B 3/18 H 01 F 27/32
Y	<u>US - A - 4 187 390</u> (GORE) * Abstract; column 1, lines 25-45; column 6, lines 3-9 * --	1,2,6	
A	<u>CH - A5 - 579 812</u> (WESTINGHOUSE) * Column 1, lines 23-64 * -----	1,2,4	
			TECHNICAL FIELDS SEARCHED (Int. Cl.5) H 01 B H 01 F 27/00
The present search report has been drawn up for all claims			
Place of search	Date of completion of the search	Examiner	
VIENNA	26-03-1991	KUTZELNIGG	
CATEGORY OF CITED DOCUMENTS X : particularly relevant if taken alone Y : particularly relevant if combined with another document of the same category A : technological background O : non-written disclosure P : intermediate document		T : theory or principle underlying the invention E : earlier patent document, but published on, or after the filing date D : document cited in the application L : document cited for other reasons & : member of the same patent family, corresponding document	