



Europäisches Patentamt
European Patent Office
Office européen des brevets



Publication number: **0 443 303 A1**

12

EUROPEAN PATENT APPLICATION

21 Application number: **90850417.8**

51 Int. Cl.⁵: **E05F 5/00, E05D 13/00**

22 Date of filing: **19.12.90**

30 Priority: **20.02.90 SE 9000605**

43 Date of publication of application:
28.08.91 Bulletin 91/35

64 Designated Contracting States:
DE DK FR GB NL SE

71 Applicant: **LUMINATOR AB**
Garverigatan, 10, Box 123
S-565 00 Mullsjö(SE)

72 Inventor: **Lageson, Stephen**
Trollehöjdsvägen 5
S-565 00 Mullsjö(SE)

74 Representative: **Bjellman, Lennart Olov Henrik**
et al
DR. LUDWIG BRANN PATENTBYRA AB
Drottninggatan 7 Box 1344
S-751 43 Uppsala(SE)

54 **Position brake for sliding doors.**

57 In summary, the present invention relates to a position brake for sliding doors. The brake includes at least one brake spring (1) deflectably thrusting into the path of travel of the door (10) such as to coact with friction-reducing elements guiding the door, e.g. plastics pads or rollers (17, 18). The brake is suitably mounted in the profile (16) placed upwards of the door for guiding it.

EP 0 443 303 A1

The present invention relates to position brakes for sliding doors, and more specifically to such a brake that can be placed optionally anywhere along the path of movement of the door, and can also be placed at several locations along this path.

Although the brake in accordance with the invention is primarily intended for sliding doors, it will be understood that it can very well be used in other applications. However, in the following it will be described in connection with sliding doors.

Sliding doors are usually arranged so that the door is provided with wheels or rollers moving along a rail on, or in the floor. Upwardly, the door is supported by a profile, generally having a downwardly open U-shape, the door being provided with laterally directed rollers engaging against the legs of the profile.

A basic desire with sliding doors is that they shall stop in their extreme positions, i.e. when a door is in its fully open and its fully closed positions, and not leave these positions until acted on by a force. It is also sometimes desirable that the door can be kept in one or more intermediate positions.

In order to achieve these different stopping positions, position brakes are at present arranged in connection with the floor rail carrying the door. However, these brakes cause up and down movement of the door when they comprise elements arranged on the rail itself. There is also considerable risk that these brakes either lose their function or become unsuitably hard to operate, due to hard particles and dust getting into them when the brake is arranged in connection with the rail carrying the door. It is also customary for the position brake to consist of depressions in the rail, particularly at the extreme positions of the door. There is no possibility of adjusting such a brake, and it cannot be moved to other positions. Neither can it be caused to come into operation temporarily, except with difficulty.

The present invention has the subject of removing the above-mentioned problems. This is achieved by a position brake of the kind described in the claims, from which the features particularly characterizing the invention are also apparent.

The invention will now be described in more detail and in connection with the accompanying drawings, in which

- FIG. 1 comprises two perspective views of a leaf spring included in a position brake according to the invention,
 FIG. 2 is a schematic, partially broken cross section of a sliding door provided with an inventive position brake, and
 FIG. 3 is a partial section taken along the line III-III in Fig. 2.

In Fig. 1 there is illustrated a brake spring 1,

intended for use in a position brake for sliding doors. The spring is made from metal sheet, plastics or other resilient material that may be given the illustrated shape. The brake spring accordingly comprises an angularly bent portion 2 with substantially a right angle between its flange 3 and its web 4. Further, the flange 3 is provided with two through-holes 5 for fastening means for the mounting of the spring. The web 4 is intended to be supported by a member behind it, as will be described later on. From the web 4 a resilient leaf part 6 extends outwardly, substantially in the direction of the fold line 7 between the flange 3 and web 4. The leaf part 6 is angled somewhat outwards from the web 4 to the same side as the one having the flange 3. The free end of the leaf part 6 is rounded off by bending it backwards, for reasons which will be explained later on.

Fig. 2 is a cross section through a sliding door 10, which at its lower edge is provided with wheels 11 in a multiplicity appropriate to the size of the door. The wheel 11 is mounted for rotation in a not more closely illustrated profile 12, and has a circumferential groove 13 of a suitably rounded shape. This wheel 11 runs along a rail 14 the shape of which is complementary to the groove 13 of the wheel 11. In turn, the rail 14 constitutes a part of a profile 15 resting on a substructure, preferably a floor. In this case the profile 15 may be likened to a threshold or door sill. With the described configuration there is obtained a reliable guidance of the sliding door 10, and an easy motion of it. It is also easy to keep clean round the rail 14, and thus avoid operational disturbances due to the collection of dust and dirt around and on the rail.

At its upper end the sliding door 10 moves in a substantially U-shaped profile 16, which is downwardly open. To ensure that the door moves smoothly also in this U-profile, there are two rollers 17, 18 rotatably mounted on a profile 19 arranged along the upper edge of the door. The rollers 17, 18 are preferably arranged in pairs, and in a multiplicity suited to the individual door. The circumferences of these wheels project slightly outside the profile 19 into light engagement against the insides of the dependent legs 20, 21 of the profile 16.

It is usual that there are at least two doors sliding mutually parallel, which requires doubling the upper 16 and lower 15 profiles, which is indicated by the respective projecting portions 22 and 23, constituting intermediate portions to other profiles 16, 15. In many cases two or more doors slide one after the other on the same rail 14. It is important here that the respective sliding doors may be stopped in their envisaged positions and remain stationary, until a certain force is applied to

them for moving them out of these positions into other such positions or completely optional positions where it is, however, not certain that they remain.

When a sliding door arrives at an end position it rebounds slightly, and if there is no brake the door has perhaps sufficient momentum to roll into a completely or partially open position. If the door moves as smoothly and easily as the one described here, it will be very irritating when the door hardly ever stops by itself in the position into which it has been pushed or pulled.

As will be seen in Fig. 2, the upper U-shaped profile 16 has along its entire length a recess 24, into which screws 25 can be screwed anywhere along it. The recess 24 is at a distance from the adjacent leg 20 corresponding to the distance from the centres of the holes 5 to the folding line 7 of the spring 1. It is thus possible to arrange any number of position brakes in optional positions along the U-shaped profile 16 with the aid of the spring 1 and a pair of screws 25.

In Fig. 3 there is illustrated a position brake situated such as to brake or retain the door 10 in an intermediate position along its path. Here the position brake comprises two springs 1 in mirrored relationship with the leaf portions 6 mutually opposed, and with a small distance between their free, backwardly bent ends. The leaf portions 6 thrust resiliently into the path of the roller 17, and when the door is moved the roller first presses away the leaf portion 6 against its sloping surface, thus braking the door 10. Thereafter, when the roller 17 is located between the backwardly bent ends 8, the backwardly bent end 8 hit by the wheel gives a relatively hard braking action simultaneously as the behind located leaf portion 6 springs outwardly, and its end bent backwards gives a braking action against returning of the door 10. When the door is to be moved away from the depicted position, a certain force must be applied to it to overcome the retaining force of the respective brake spring 1.

When the door 10 arrives at an end position where there is a constructional stop preventing further movement of the door, it is sufficient with a single brake spring 1, whereas two springs are required for each intermediate stopping position, as mentioned.

The invention has been described here in an embodiment where the position brake is placed in the upper U-shaped profile 16, which is to be preferred, since it is then concealed and does not collect dust and dirt that could disturb its operation. The braking action on the door is mostly in the lateral direction, and thus there are no notable disturbing movements of the door when the door is thrust past a position brake intended as a stop in

the opposite direction of travel. Brakes acting in the vertical direction of the sliding door often cause troublesome movements of the door, as well as a bumping noise. In addition, it often happens that such brakes mounted in connection with the floor rail cause derailing of the door. A possible location of the position brake in accordance with the invention could however be in the U-shaped profile 16, such that the brake acts downwards and in coaction with a special braking wheel. This would result in an unnecessarily complicated structure, without any great advantage in comparison with the one described, which functions without any other arrangement than one or two springs 1 for each position, which of course is optional. Instead of the rollers 17, 18, low-friction plastics pads could be used, and arranged such that they slide against the dependent legs of the U-shaped profile 16.

With the aid of the present invention there has thus been achieved the object set forth in the introduction. One skilled in the art can of course modify the invention for different applications, but such modifications are intended to lie within the scope of the invention, such as it is defined in the accompanying claims.

Claims

1. Position brake for sliding doors, for placing at optional locations inside a profile guiding the sliding door (10), and taking the form of a brake spring (1) comprising a resilient leaf portion (6) and a fastening portion (3), characterized in that the brake spring includes a flanged portion (2) with substantially a right angle between its flange (3) and its web (4), the flange (3) constituting the fastening portion, which is provided with at least one through-hole (5) for a fastening means, and in that the leaf portion (6) constitutes an extension of the web (4) and departs therefrom at an angle, the position brake being intended to act against an unloaded, friction-reducing element, e.g. a guide roller (17, 18), mounted on the door.
2. Brake as claimed in claim 1, characterized in that the free end of the leaf portion (6) has a backwardly bent portion (8).
3. Brake as claimed in claim 1 or 2, characterized in that it is intended for mounting in the profile (16) upwardly guiding the door (10), and in such a case acting in a plane perpendicular to the plane of travel of the sliding door (10).
4. Brake as claimed in any one of claims 1-3, characterized in that it includes two brake springs (1) the resilient leaf portions (6) of

which are mutually opposed.

5

10

15

20

25

30

35

40

45

50

55

4

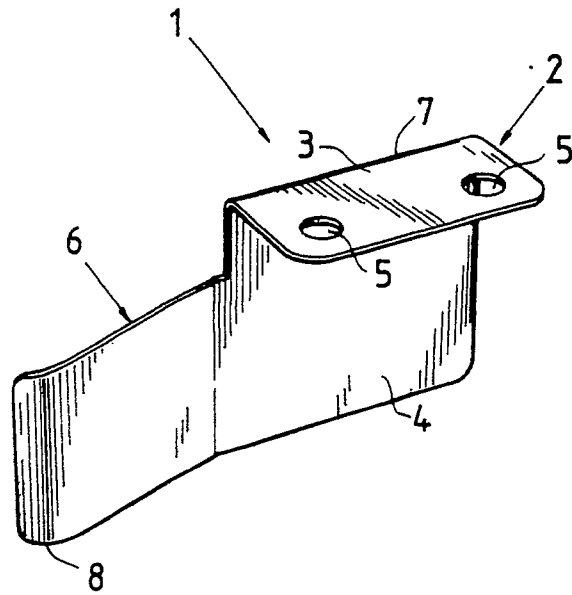
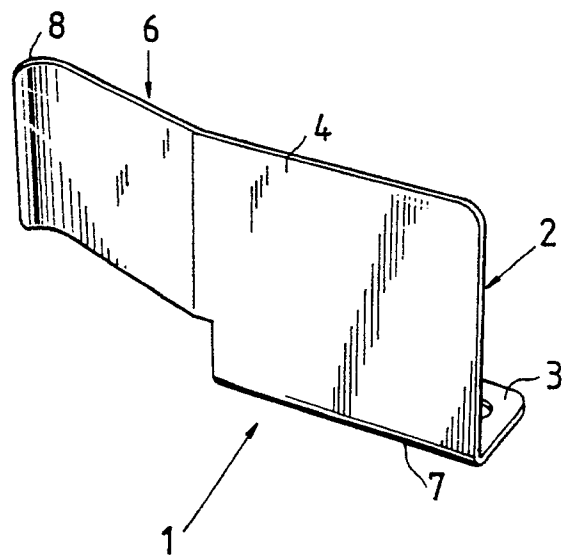

Fig. 1



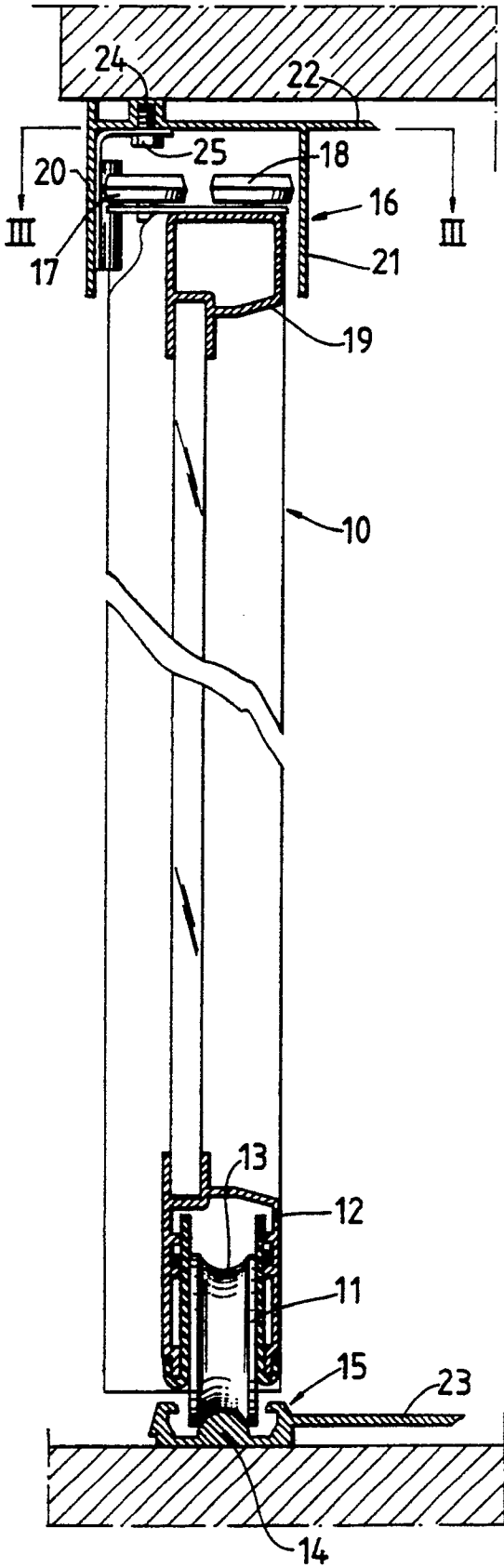

Fig. 2

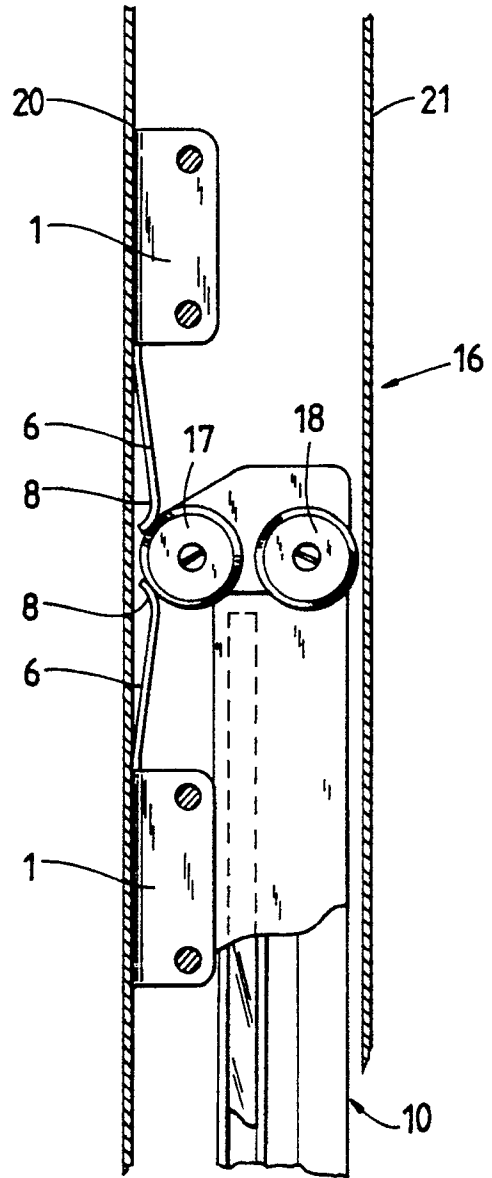

Fig. 3



DOCUMENTS CONSIDERED TO BE RELEVANT			
Category	Citation of document with indication, where appropriate, of relevant passages	Relevant to claim	CLASSIFICATION OF THE APPLICATION (Int. Cl.5)
Y	US-A-4 183 179 (GUTRIDGE) * column 2, line 13 - line 20; figures 2,3 * - - -	1-3	E 05 F 5/00 E 05 D 13/00
Y	US-A-3 166 347 (R. ANDREWS) * column 4, line 1 - column 10; figures 7,9 * - - -	1-3	
A	DE-U-8 405 712 (J. GARTNER) * page 5, line 23 - page 6, line 30; figures 2-4,6,8 * - - -	1-4	
A	DE-U-8 601 328 (P. HETTICH) * figure 1 * - - - - -	4	
			TECHNICAL FIELDS SEARCHED (Int. Cl.5)
			E 05 F E 05 D
The present search report has been drawn up for all claims			
Place of search		Date of completion of search	Examiner
The Hague		18 April 91	GUILLAUME G.E.P.
<p>CATEGORY OF CITED DOCUMENTS</p> <p>X : particularly relevant if taken alone</p> <p>Y : particularly relevant if combined with another document of the same category</p> <p>A : technological background</p> <p>O : non-written disclosure</p> <p>P : intermediate document</p> <p>T : theory or principle underlying the invention</p> <p>E : earlier patent document, but published on, or after the filing date</p> <p>D : document cited in the application</p> <p>L : document cited for other reasons</p> <p>& : member of the same patent family, corresponding document</p>			