



Europäisches Patentamt  
European Patent Office  
Office européen des brevets



Publication number:

**0 444 516 B1**

12

## EUROPEAN PATENT SPECIFICATION

49 Date of publication of patent specification: **30.11.94** 51 Int. Cl.<sup>5</sup>: **A47L 5/28**

21 Application number: **91102452.9**

22 Date of filing: **20.02.91**

54 **Stick type vacuum cleaner.**

30 Priority: **01.03.90 US 486936**

43 Date of publication of application:  
**04.09.91 Bulletin 91/36**

45 Publication of the grant of the patent:  
**30.11.94 Bulletin 94/48**

84 Designated Contracting States:  
**DE ES FR GB IT NL SE**

56 References cited:  
**EP-A- 0 286 203**  
**DE-A- 3 430 402**  
**US-A- 4 621 390**

73 Proprietor: **White Consolidated Industries, Inc.**  
**11770 Berea Road**  
**Cleveland Ohio 44111 (US)**

72 Inventor: **Ferrari, Marco**  
**516 East University Street**  
**Bloomington Illinois 61701 (US)**  
Inventor: **Fowler, Michael R.**  
**1009 Porter Lane**  
**Normal Illinois 61761 (US)**  
Inventor: **McVey, Kelly**  
**107 Meadowbrook Drive**  
**Bloomington, Illinois 61701 (US)**

74 Representative: **Herrmann-Trentepohl, Werner, Dipl.-Ing. et al**  
**Patentanwälte Herrmann-Trentepohl,**  
**Kirschner, Grosse, Bockhorni & Partner**  
**Forstenrieder Allee 59**  
**D-81476 München (DE)**

**EP 0 444 516 B1**

Note: Within nine months from the publication of the mention of the grant of the European patent, any person may give notice to the European Patent Office of opposition to the European patent granted. Notice of opposition shall be filed in a written reasoned statement. It shall not be deemed to have been filed until the opposition fee has been paid (Art. 99(1) European patent convention).

## Description

The present invention relates to a stick type vacuum cleaner having a porous filter bag and a re-usable dirt cup, the latter being for accumulating dirt picked up from the rug, or the like, during the vacuuming operation.

### BACKGROUND OF THE INVENTION

Stick type vacuum cleaners are known in which each of the cleaners is provided with a vacuum pump, a dirt tube and a porous bag for receiving the dirt entrained in the air stream and conducting the dirt into a reusable dirt cup that is attached to the housing of the vacuum cleaner. Such an arrangement is shown in U.S. Patent No. 3,199,138 to Nordeen which corresponds to the preamble of claim 1.

However, in the prior art stick type vacuum cleaners the handles are not adapted for multiple uses and, for example, it is difficult to vacuum stairs with such a device since it is elongated and if it is held vertically both the stairs and the risers cannot be adequately cleaned. DE-A-34 30 402 discloses a handle having two grasping portions such as the claimed invention. However it does not disclose a grip on the lower housing, so that this vacuum cleaner can be used in an upright position and in a horizontal position but not for above-floor operations as intended by the claimed invention. Consequently, it is an object of the present invention to provide a two position handle for a stick vacuum cleaner which can be used in one position for up-right cleaning and in another position for above-floor cleaning operations and for substantially horizontal cleaning in conjunction with a molded-in handle on the lower housing of the cleaner. Thus, stairs and risers can be adequately vacuumed.

The present vacuum cleaner is a light-weight, up-right construction and includes a vacuum motor for drawing dirt laden air into a housing, and discharging the dirt into a dirt cup as the air passes through a porous filter bag.

It is another object of the present invention to provide a support beam, or post, for a vacuum cleaner bag, which is connected to the lower housing at one end and a handle at the other end, which is disposed outside of said bag and the dirt cup.

It is an object of the present invention to provide an integral molded-in hand hold in the lower housing of the vacuum cleaner for assisting in the lifting of the nozzle of the vacuum cleaner during stair cleaning operation.

The invention is disclosed in the characterizing part of claim 1 in connection with the preamble of

the claim itself.

### BRIEF DESCRIPTION OF THE DRAWINGS

5 In order that the invention be more clearly understood, it will now be disclosed in greater detail with reference to the accompanying drawings, wherein:

10 Fig. 1 is a side elevation view of the stick vacuum cleaner constructed in accordance with the teachings of the present invention.

Fig. 2 is a cross-sectional view the device shown in Fig. 1.

15 Fig. 2a is an alternate embodiment of the dirt tube location in the present invention.

Fig. 3 is a substantially perspective view of the stick vacuum cleaner in use on a floor or floor covering.

20 Fig. 4 is a rear elevation view of a vacuum cleaner shown in Fig. 3.

Fig. 5 is an enlarged side elevational view of the handle portion of the vacuum cleaner.

Fig. 6 is a cross-sectional view of the handle shown in Fig. 5.

25 Fig. 7 is a perspective of the stick vacuum cleaner shown in a substantially horizontal position for vacuuming stairs or the like.

30 Fig. 8 is an enlarged fragmentary exploded view of the invention showing the dirt cup removed from the device and also showing the motor housing and porous filter bag.

Fig. 9 is a bottom plan view of the nozzle for the stick vacuum cleaner showing the bristle strip, as well as the wheel assembly.

35 Fig. 10 is a rear view of the nozzle shown in Fig. 9.

Fig. 11 is a side elevational view thereof.

40 Fig. 12 is a top plan view of another embodiment of the nozzle incorporating a foot pedal switch.

Fig. 13 is a bottom plan view thereof.

Fig. 14 is a side elevation thereof.

45 Fig. 15 is a top plan view showing the foot pedal switch of the embodiment shown in Fig. 9.

Fig. 16 is a top plan view of the dirt cup for the stick vacuum cleaner.

Fig. 17 is a front elevational view thereof.

Fig. 18 is a view taken along the lines 18-18 of Fig. 17,

50 Fig. 19 is a sectional view taken along the lines 19-19 of Fig. 16.

Fig. 20 is a front elevational view of the latch device which is movable within the dirt cup for securing and releasing the dirt cup from the vacuum cleaner.

55 Fig. 21 is a side elevational view thereof.

Fig. 22 is a rear elevational view of the latch shown in Fig. 20.

Fig. 23 is a view taken along the lines 23-23 of Fig. 22.

Fig. 24 is a view taken along the lines 24-24 of Figs. 22 and

Fig. 25 is a view taken along the lines 25-25 of Fig. 22.

#### DESCRIPTION OF THE PREFERRED EMBODIMENT

The lightweight stick type vacuum cleaner, as seen in Figs. 1-4 is provided with a lower housing 10 having a tubular extension 12 and the nozzle 14 pivotally attached to the extension 12 at pivot point 16. As seen in Fig. 2, an electric motor 18 and an impeller fan 20 are mounted in the lower housing 10 forming a vacuum pump for the cleaner. A dirt tube 22 is also provided for conducting air-entrained dirt into a porous filter bag 24.

The lower housing is connected to the upper handle assembly 26 by means of a cylindrical handle tube 28 located behind the porous bag and removable dirt cup 30. Consequently, dirt-laden air which enters the vacuum cleaner device through the opening 14a in the nozzle moves through the dirt tube 22 and exits into the bottom of the porous cloth filter bag 24, and thereafter the air-entrained dirt falls by gravity into the dirt cup 30, while the air flow continues up into the filter bag 24 and out to the atmosphere through the minute openings of the filter bag. However, sometimes in use, some dirt and debris clings to the inside of the porous bag 24 and is removed by means of a bag shaker 32 having a lower ring 34 attached to the top of the filter bag 24. The bag shaker 32 is provided at its upper end with a pair of springs 36, each being attached at one end to the shaker mechanism 32 and at the other end to the handle assembly 26.

It should be noted that the handle assembly is in the form of a closed loop provided a void 38 for inserting the fingers of the hand therethrough.

Referring particularly to Figs. 5 and 6 showing the handle portion 26 of the vacuum cleaner which has a two-position hand grip, in which one hand grip portion 39 is substantially linear, and in which a second handle portion 40 is integral with the hand grip portion 39, and is at an obtuse angle thereto. Thus, the user/operator of the vacuum cleaner will use the handle portion 40 when the cleaner is held at an angle for cleaning floors and floor coverings, as seen in Fig. 3, and the handle portion 39 is utilized when vacuuming stairs and risers, as seen in Fig. 7. In order to make the vacuuming of stairs and risers easier to accomplish a hand-hold 42 is provided in lower housing 10 which particularly utilizes the construction, seen in Fig. 7, as well as in Figs. 1-3.

As illustrated in Fig. 2, the handle 26 is provided with a reduced cylindrical insert 27 which fits within an end 29 of the cylindrical handle tube 28 which connects the lower housing to the handle assembly.

At the bottom of the handle 26 is a cord retainer 43 while at the top of handle 26 is mounted a cord retainer 44, for wrapping the electric power cord when not in use. As further seen in Figs. 5 and 6, the hand grip portions 39 and 40 are shaped for gripping the selected handle portion without the operator's hand slipping out of position.

An alternate embodiment of the present invention is illustrated in Fig. 2a showing the dirt tube 22a extending behind the dirt cup 30 and entering the porous filter bag 24a at an intermediate portion thereof, or at top of the bag. In this construction, the dirt tube functions not only to conduct the dirt-laden air into the filter bag but also acts as the connecting support member between the lower housing 10 and the handle assembly.

The nozzle of the present stick vacuum cleaner is provided with a small wheel assembly 50 as shown in Figs. 9-13. The nozzle opening 52 is provided with a bristle strip 54, as clearly seen in Figs. 9 and 10. In addition, the nozzle housing 56 has an opening 58 through which a rocker foot pedal 60 projects, as shown in Figs. 10.

The embodiment shown in Figs. 12-14 is provided with large nozzle propelling wheels 62 for ease in movement of the nozzle head. Pivotaly secured to the nozzle casing 56 is an elbow 64 for insertion within the tubular extension 12 of the lower housing 10, as particularly seen in Fig. 2. As seen in Fig. 13 the alternate embodiment of the nozzle construction is provided with a bristle strip 68 in the opening 70 of the nozzle housing 72.

A removable dirt cup 30 is illustrated in Figs. 8 and 16-19, and which is adapted to be inserted in the opening 33 between the hand hold 42 and the porous cloth bag 24, (Fig. 8). The dirt cup 30 is provided with a latch assembly referred to generally by the reference numeral 76, and particularly shown in Figs. 20-25 of the drawings. As seen in Fig. 8 the dirt cup has a keyway 35 in the bottom thereof for accommodating the latch assembly 76, and a track 37 on the top surface of the lower housing 10. The latch assembly 76, in addition, is provided with somewhat flexible legs 78 having end hooks 80. Furthermore, the latch assembly 76 is provided with an element 82 having slightly flexible finger pieces 84, as well as a cam 86 on the bottom of the latch. The latch assembly 76 fits within the dirt cup 30 and has limited movement therein but cannot be removed therefrom. Consequently, when it is desired to install the dirt cup 30 within the opening between the lower motor housing and cloth dirt bag, the cup 30 is pushed

into the opening and slides on the track 37 on the lower housing 10 and the cam 86 located on the bottom of the latch wedges against the lower housing of the vacuum cleaner thus locking the dirt cup in place on the stick vacuum. Since the latch assembly 76 moves freely with limited movement within the dirt cup the latter can be removed by squeezing the latch finger pieces 84 and pulling out the latch assembly whereby the cam 86 is released from the lower housing. The latch assembly, however, cannot be separated from the dirt cup since it is retained within the cup by the end hooks 80 of the legs 78 being retained in the keyways 35 of the dirt cup 30.

Fig. 19 shows the latch assembly 76 fully inserted within the keyway 35 of the dirt cup 30. It will again be noted that when the dirt cup 30 is pushed in the opening 33 and assumes the position shown in Fig. 2 the cam 86 of the latch assembly 76 is forced into engagement with the top surface of the lower housing 10 thereby maintaining the dirt cup into a latched position in the open space 33 between the bottom of the porous cloth bag 24 and the top of the lower housing 10.

As seen in Fig. 2, the dirt cup is provided with an open top 30a communicated with the porous bag 24 in order to permit the free fall of air-entrained dirt into the dirt cup 30. Furthermore, as stated above, the dirt cup 30 can be removed from the stick vacuum cleaner by grasping the finger pieces 84 on the latch assembly 76 and pulling the latch in a direction out of the dirt cup a limited distance thereby causing the cam 86 to be dislodged from engagement with the top surface of the lower housing 10.

As seen in Figs. 1-6 an on/off switch 95 is shown which is connected to a power source (not shown) and which is provided in the handle 26 for operating the present stick vacuum cleaner.

### Claims

1. An upright stick-type vacuum cleaner having a lower housing (10), a nozzle (14) movably attached to said lower housing (10), a handle (26), a support member (28) connecting said lower housing (10) to the handle (26), a vacuum pump located in the lower housing, a porous bag (24), a dirt cup (30) and a dirt tube (22) for conducting dust and dirt laden air whereby said dust and dirt is deposited in said dirt cup (30), while the air passes through said porous bag (24) to the atmosphere, **characterized by** a hand grip (42) on said lower housing (10), said handle (26) being loop-shaped and having one handle portion (39) essentially in parallel with the longitudinal axis of the stick-type vacuum cleaner and a

second handle portion (40) being integral with the first handle portion (39) and at an obtuse angle thereto, whereby the two handle portions are designed to be alternately grasped, the second portion (40) being for upright cleaning operation of the vacuum cleaner and the first portion (39) together with said hand grip (42) being for above-floor cleaning operation of the vacuum cleaner.

2. The vacuum cleaner as claimed in claim 1 **wherein** said support member (28) is an elongated rigid element that is located outside of said porous bag (24) and said dirt cup (30).
3. The vacuum cleaner as claimed in claim 1 **wherein** the dirt cup (30) has a finger-operated latch (76) fixedly mounted for restricted movement on the bottom of said dirt cup (30), said latch (76) having a cam (86) for frictional engagement between the bottom of the dirt cup and a top surface of said lower housing when said dirt cup (30) is inserted in said vacuum cleaner.
4. The vacuum cleaner as claimed in one of the previous claims, **wherein** said dirt tube (22) is connected to the bottom of said porous bag (24).
5. The vacuum cleaner as claimed in one of the previous claims, **wherein** said support member (28) is a cylindrically-shaped tube and said handle (26) is provided with a cylindrical post (27) for insertion in said support member (28) to thereby assemble said vacuum cleaner.
6. The vacuum cleaner as claimed in one of the previous claims, **wherein** said loop shaped handle (26) has a handle gripping portion provided with a first handle gripping section (39) and an integral second hand gripping section (40) angularly disposed relative thereto.
7. The vacuum cleaner as claimed in one of the previous claims, **wherein** said dirt tube (22) is connected to said porous bag (24) at a location above the lower end thereof.
8. The vacuum cleaner as claimed in one of the previous claims, **wherein** said dirt cup (30) is removable from the lower housing (10) without removing the porous bag (24).
9. The vacuum cleaner as claimed in one of the previous claims, **wherein** the movement of the latch (76) is restricted by the latch being retained within keyways (35) on the bottom of

the dirt cup (30).

10. The vacuum cleaner as claimed in one of the previous claims **characterized by** a shaker (32) having an actuating portion extending into the loop-shaped handle (26) and connected to the porous bag (24) whereby the porous bag (24) can be shaken by the actuating portion in the handle (26).
11. The vacuum cleaner as claimed in claim 10, **wherein** the shaker (32) is mounted in the support member (28).
12. The vacuum cleaner as claimed in claim 11, **wherein** the shaker (32) is connected to the top of the porous bag (24) and the actuating portion extends into the lower end of the handle (26).
13. The vacuum cleaner as claimed in claim 12, **wherein** the actuating portion is located above the top of the porous bag.

#### Patentansprüche

1. Aufrecht arbeitender Staubsauger mit einem unteren Gehäuse (10), einem Düsenansatz (14), der beweglich an genanntem unteren Gehäuse (10) angebracht ist, einem Griff (26), einem Tragglied (28), das das genannte untere Gehäuse (10) mit dem Griff (26) verbindet, einer im unteren Gehäuse befindlichen Vakuumpumpe, einem durchlässigen Beutel (24), einem Staubbehälter (30) und einem Staubrohr (22), um staub- und schmutzhaltige Luft zu führen, durch die der genannte Staub und Schmutz in dem genannten Staubbehälter (30) gelagert wird, während die Luft durch den genannten durchlässigen Beutel (24) nach außen gelangt, **gekennzeichnet durch** einen Handgriff (42) an dem genannten unteren Gehäuse (10), wobei der genannte Griff (26) schleifenförmig ausgeführt ist und einen Greifabschnitt (39), der im wesentlichen parallel zu der Längsachse des Staubsaugers verläuft, sowie einen zweiten Greifabschnitt (40), der in einem Stück mit dem ersten Greifabschnitt (39) und in einem stumpfen Winkel zu diesem ausgeführt ist, aufweist, wobei die beiden Greifabschnitte dazu bestimmt sind, alternativ ergriffen zu werden, wobei der zweite Abschnitt (40) für den Saugvorgang bei aufrechter Position des Staubsaugers vorgesehen ist, und der erste Abschnitt (39) zusammen mit dem genannten Handgriff (42) zum Saugen des Staubsaugers über dem Boden vorgesehen ist.

2. Staubsauger nach Anspruch 1, wobei das genannte Tragglied (28) ein längliches, steifes Element ist, das sich außerhalb des genannten durchlässigen Beutels (24) und des genannten Staubbehälters (30) befindet.
3. Staubsauger nach Anspruch 1, wobei der Staubbehälter (30) einen mit dem Finger zu betätigenden Riegel (76) besitzt, der am Boden des genannten Staubbehälters (30) fest angebracht ist, so daß er eine begrenzte Bewegung ausführen kann, wobei der genannte Riegel (76) einen Nocken (86) aufweist, der für den Reibeingriff zwischen dem Boden des Staubbehälters und einer Oberseite des genannten unteren Gehäuses vorgesehen ist, wenn der genannte Staubbehälter (30) in den genannten Staubsauger eingesetzt wird.
4. Staubsauger nach einem der vorherigen Ansprüche, wobei das genannte Staubrohr (22) mit dem Boden des genannten durchlässigen Beutels (24) verbunden ist.
5. Staubsauger nach einem der vorherigen Ansprüche, wobei das genannte Tragglied (28) ein zylindrisches Rohr ist und der genannte Griff (26) mit einem zylindrischen Stab (27) versehen ist, der zum Einsetzen in das genannte Tragglied (28) bestimmt ist, wodurch der genannte Staubsauger zusammengesetzt wird.
6. Staubsauger nach einem der vorherigen Ansprüche, wobei der genannte schleifenförmige Griff (26) ein Griffteil mit einem ersten Greifabschnitt (39) und einem in einem Stück mit diesem ausgeführten und in einem Winkel zu diesem angeordneten zweiten Greifabschnitt (40) aufweist.
7. Staubsauger nach einem der vorherigen Ansprüche, wobei das genannte Staubrohr (22) mit dem genannten durchlässigen Beutel (24) an einer Stelle oberhalb von dessen unterem Ende verbunden ist.
8. Staubsauger nach einem der vorherigen Ansprüche, wobei der genannte Staubbehälter (30) aus dem unteren Gehäuse (10) herausgenommen werden kann, ohne den durchlässigen Beutel (24) zu entfernen.
9. Staubsauger nach einem der vorherigen Ansprüche, wobei die Bewegung des Riegels (76) dadurch begrenzt wird, daß der Riegel in Keilnuten (35) am Boden des Staubbehälters (30) gehalten wird.

10. Staubsauger nach einem der vorherigen Ansprüche, **gekennzeichnet durch** einen Rüttler (32), dessen Betätigungsabschnitt in den schleifenförmigen Griff (26) hineinragt und mit dem durchlässigen Beutel (24) verbunden ist, so daß der durchlässige Beutel (24) mit dem Betätigungsabschnitt in dem Griff (26) gerüttelt werden kann.
11. Staubsauger nach Anspruch 10, wobei der Rüttler (32) in dem Tragglied (28) eingebaut ist.
12. Staubsauger nach Anspruch 11, wobei der Rüttler (32) mit dem oberen Ende des durchlässigen Beutels (24) verbunden ist und der Betätigungsabschnitt in das untere Ende des schleifenförmigen Griffs (26) hineinragt.
13. Staubsauger nach Anspruch 12, wobei der Betätigungsabschnitt über dem oberen Ende des durchlässigen Beutels (24) angeordnet ist.

#### Revendications

1. Aspirateur de type balai présentant un boîtier inférieur (10), un suceur (14) fixé de façon amovible audit boîtier inférieur (10), une poignée (26), un organe de support (28) reliant ledit boîtier inférieur (10) à la poignée (26), une pompe à vide située dans le boîtier inférieur, un sachet poreux (24), un godet à saleté (30) et un tube pour saleté (22) servant à guider l'air chargé en poussière et en saleté, de manière que lesdites poussière et saleté soient déposées dans ledit godet à saleté (30), tandis que l'air traverse ledit sachet poreux (24) vers l'atmosphère, caractérisé par un organe de saisie pour main (42) situé sur ledit boîtier inférieur (10), ladite poignée (26) étant réalisée en forme de boucle et présentant une partie de poignée (39) pratiquement parallèle à l'axe longitudinale de l'aspirateur de type balai et une seconde partie de poignée (40) étant réalisée d'un seul tenant avec la première partie de poignée (39), tout en formant un angle obtus par rapport à cette dernière, de manière que les parties de poignée soient conçues pour être alternativement saisies, la seconde partie (40) étant destinée à une opération de nettoyage avec l'aspirateur verticale et la première partie (39), conjointement avec l'organe de saisie pour main (42), étant destinée à une opération de nettoyage au-dessus du sol par l'aspirateur.
2. Aspirateur selon la revendication 1, dans lequel ledit organe de support (28) est un élément rigide allongé qui est situé à l'extérieur dudit sachet poreux (24) et dudit godet à saleté (30).
3. Aspirateur selon la revendication 1, dans lequel le godet à saleté (30) présente un premier verrou (76) actionné par un doigt, monté rigidement de façon à effectuer un déplacement limité au fond dudit godet à saleté (30), ledit verrou (76) présentant une came (86) servant à établir un contact de friction entre le fond du godet à saleté et une surface de sommet dudit boîtier inférieur, lorsque ledit godet à saleté (30) est inséré dans ledit aspirateur.
4. Aspirateur selon l'une des revendications précédentes, dans lequel ledit tube pour saleté (22) est relié au fond dudit sachet poreux (24).
5. Aspirateur selon l'une des revendications précédentes, dans lequel ledit organe de support (28) est un tube de forme cylindrique et ladite poignée (26) est pourvue d'un montant cylindrique (27) destiné à être inséré dans ledit organe de support (28), de manière à assembler ledit aspirateur.
6. Aspirateur selon l'une des revendications précédentes, dans lequel ladite poignée en forme de boucle (26) présente une partie de saisie de poignée pourvue d'une première section de saisie de poignée (39) et d'une seconde section de saisie de poignée (40), solidaire et disposée de façon angulaire par rapport à la précédente.
7. Aspirateur selon l'une des revendications précédentes, dans lequel ledit tube pour saleté (22) est relié audit sachet poreux (24), en un emplacement situé au-dessus de son extrémité inférieure.
8. Aspirateur selon l'une des revendications précédentes, dans lequel ledit godet à saleté (30) peut être retiré du boîtier inférieur (10) sans retirer le sachet poreux (24).
9. Aspirateur selon l'une des revendications précédentes, dans lequel le déplacement du verrou (76) est limité par le verrou maintenu dans des rainures de clavette (35) situées sur le fond du godet à saleté (30).
10. Aspirateur selon l'une des revendications précédentes, caractérisé par un secoueur (32) présentant une partie d'actionnement s'étendant dans la poignée en forme de boucle (26) et reliée au sachet poreux (24), de manière que le sachet poreux (24) puisse être secoué

par la partie d'actionnement située dans la poignée (26).

- 11.** Aspirateur selon la revendication 10, dans lequel le secoueur (32) est monté dans l'organe de support (28). 5
- 12.** Aspirateur selon la revendication 11, dans lequel le secoueur (32) est relié au sommet du sachet poreux (24) et la partie d'actionnement s'étend dans l'extrémité inférieure de la poignée (26). 10
- 13.** Aspirateur selon la revendication 12, dans lequel la partie d'actionnement se situe au-dessus du sommet du sachet poreux. 15

20

25

30

35

40

45

50

55

7

FIG.2

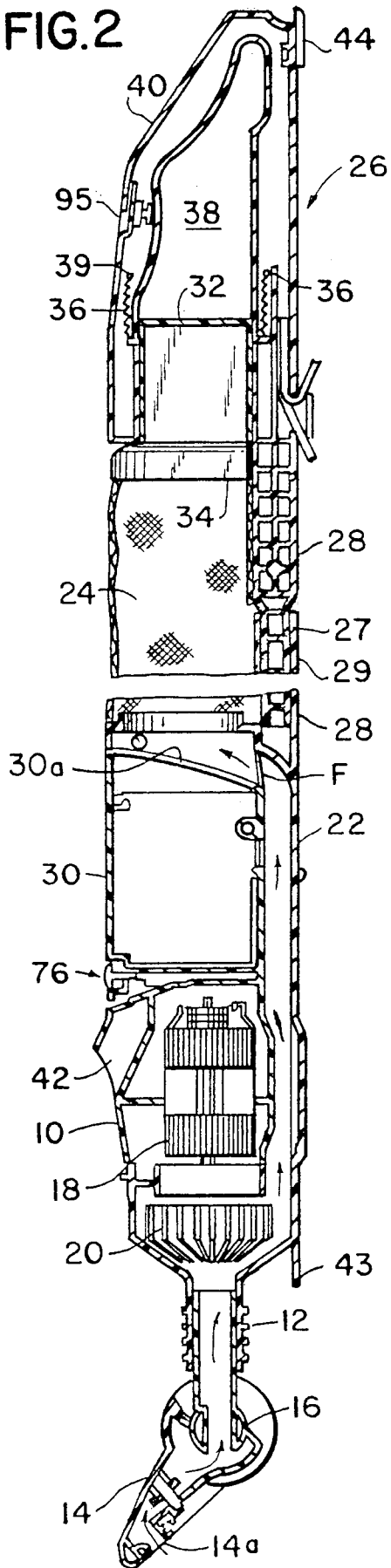

FIG.1

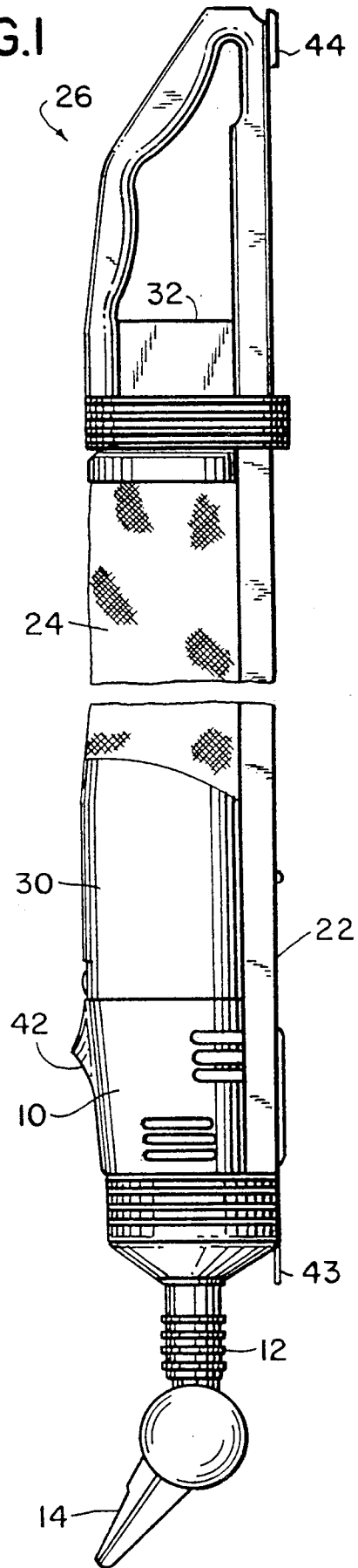
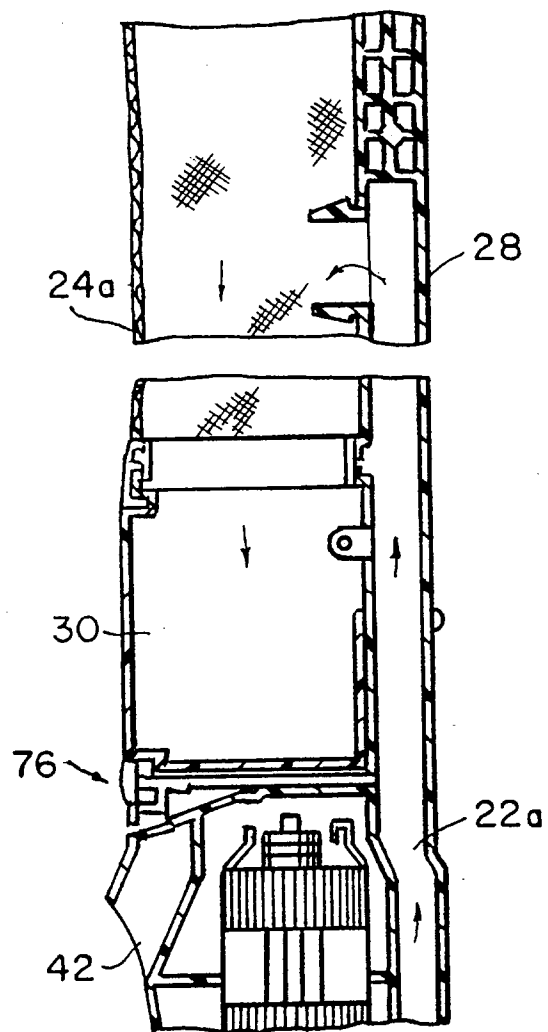

FIG.2a



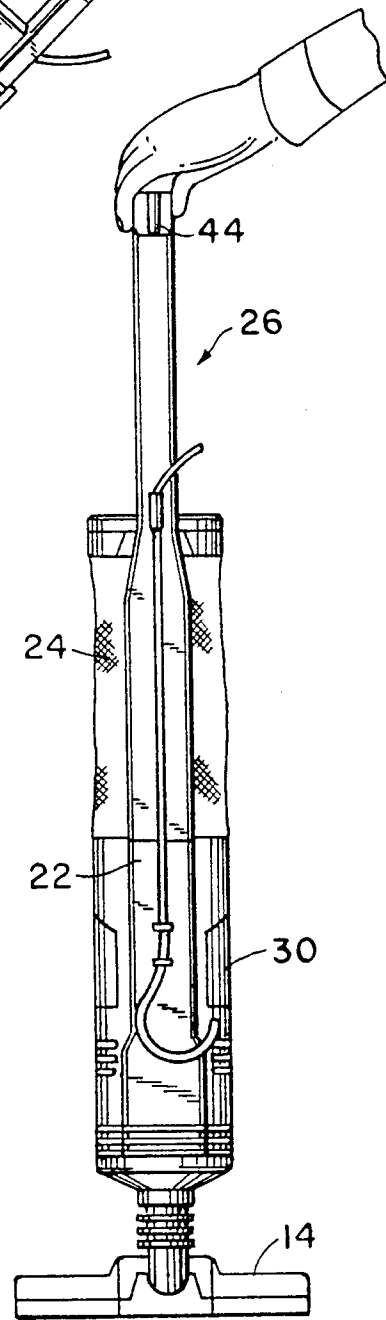
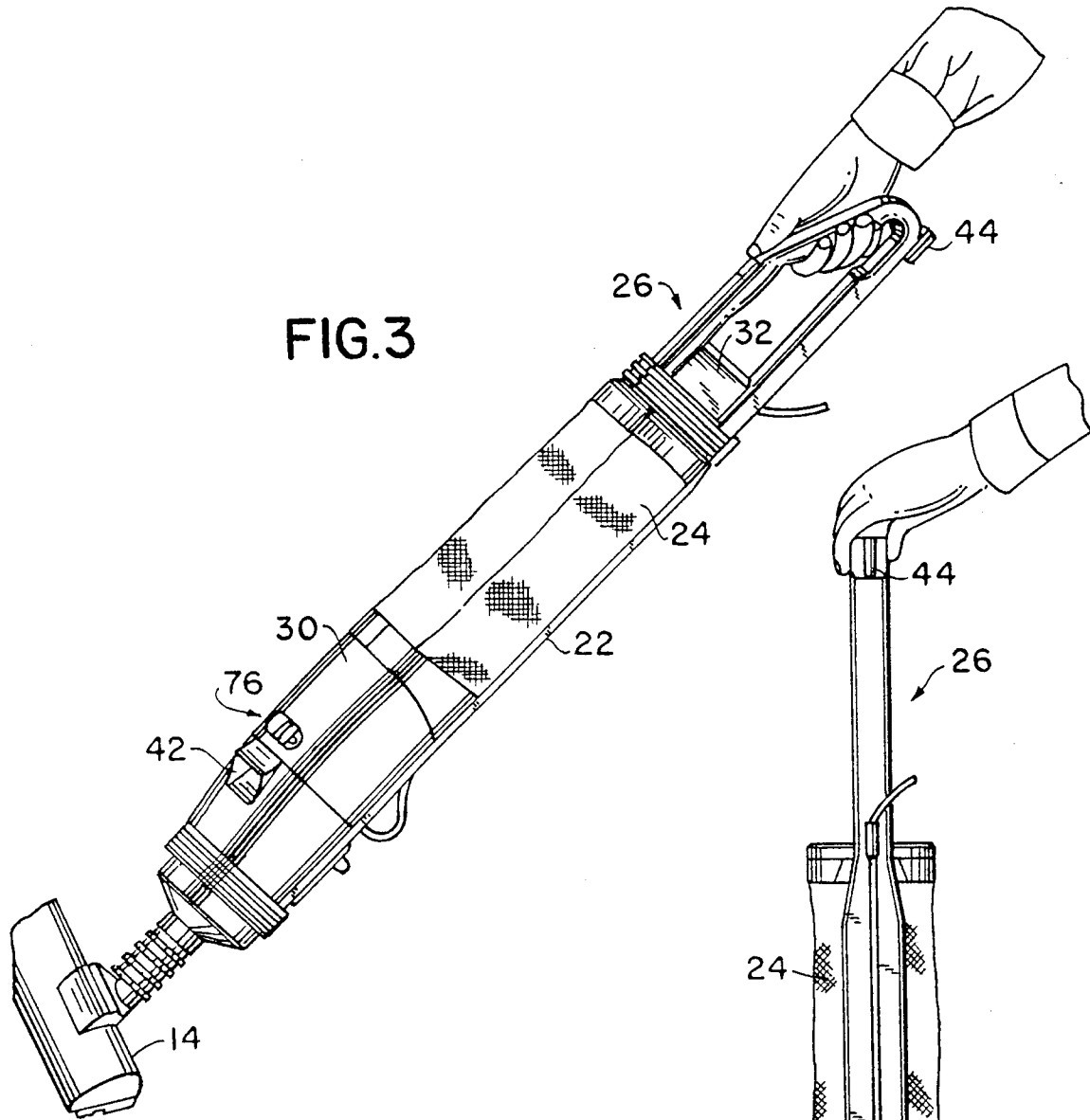

FIG.5

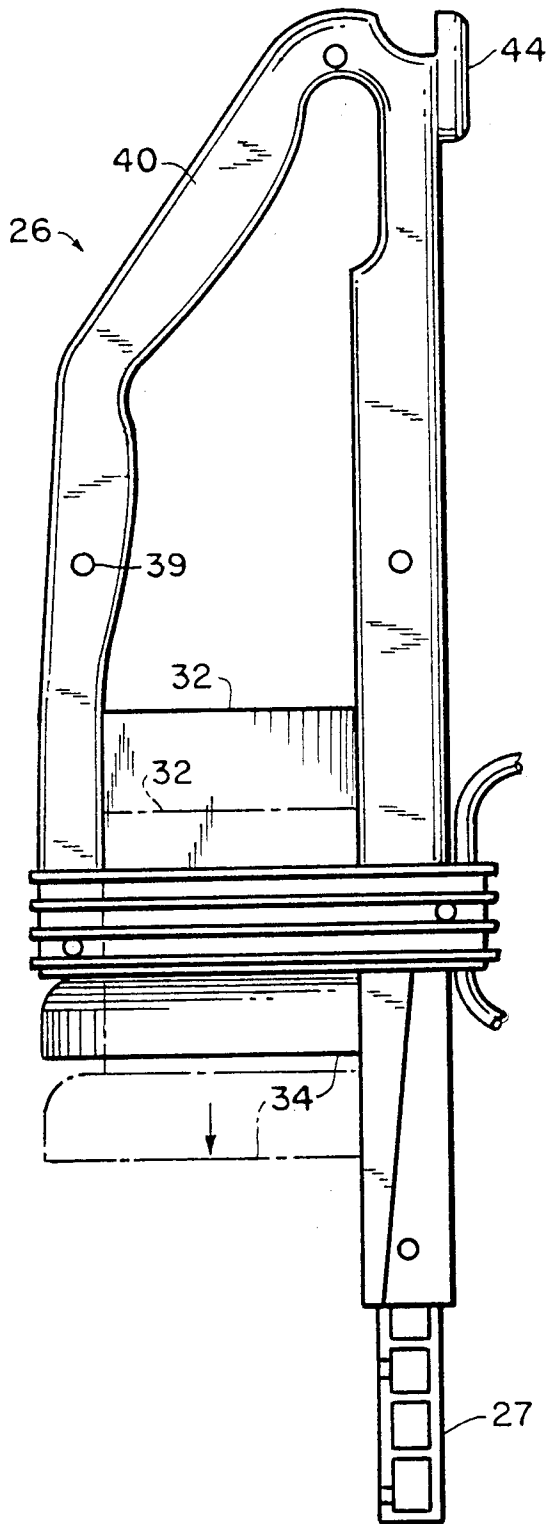
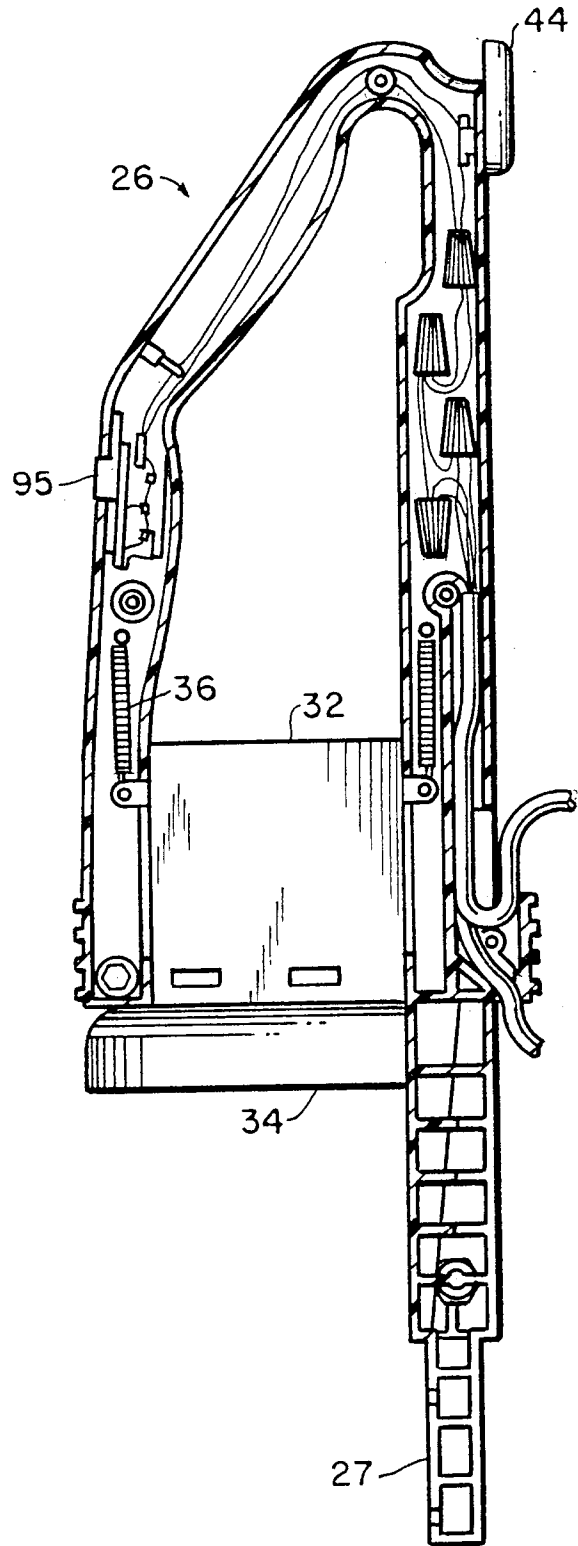

FIG.6



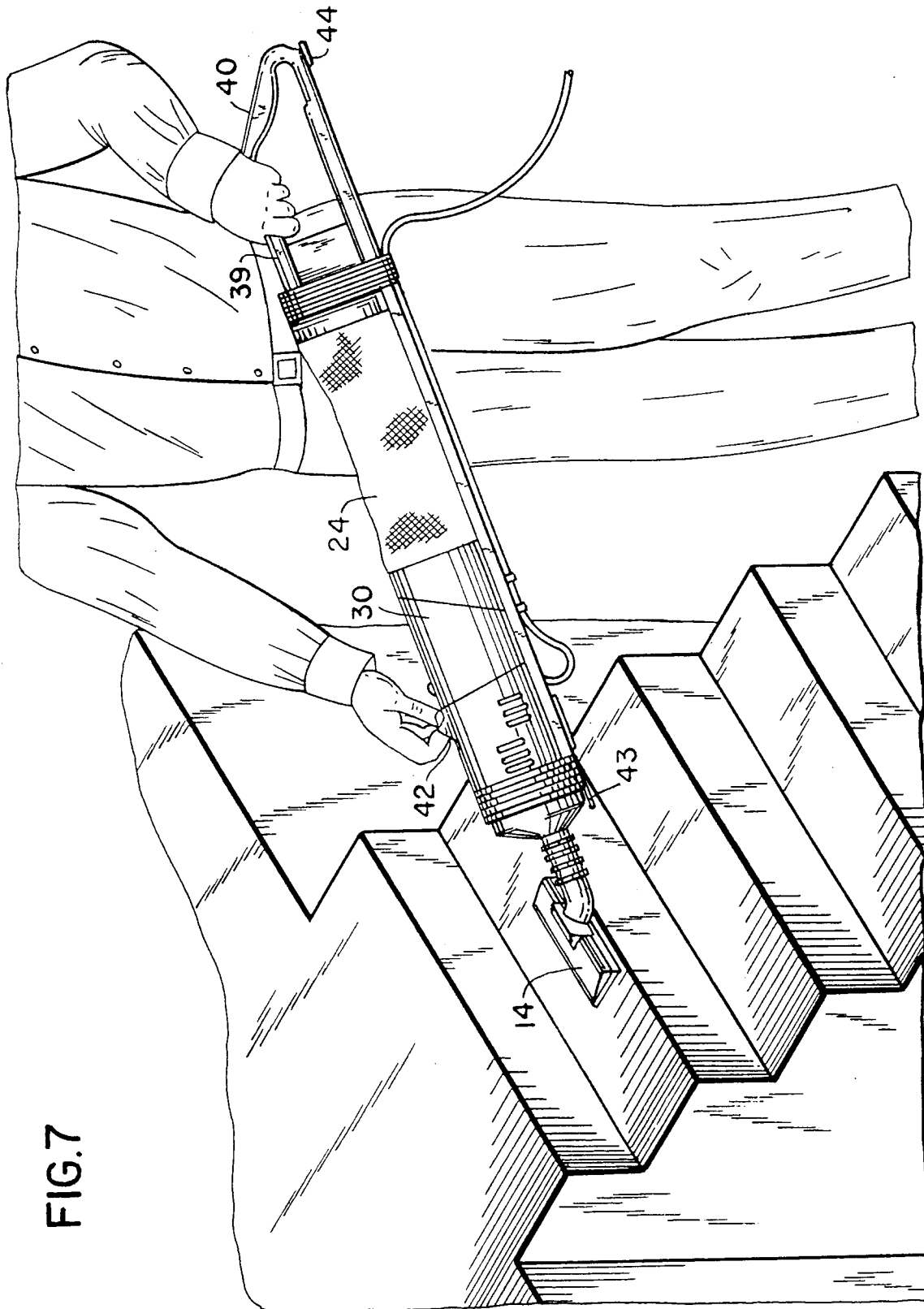

FIG.7

FIG.8

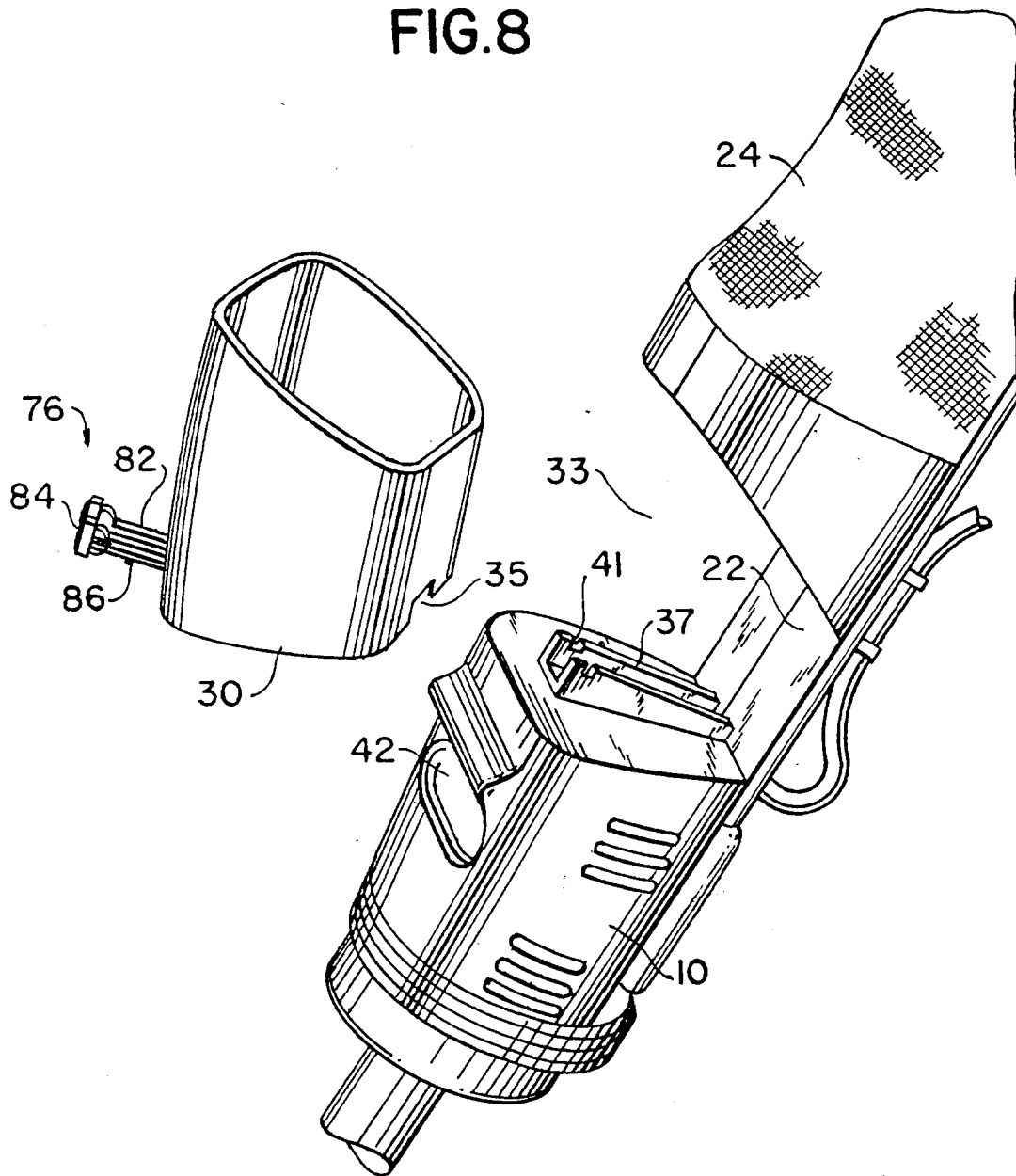

FIG.9

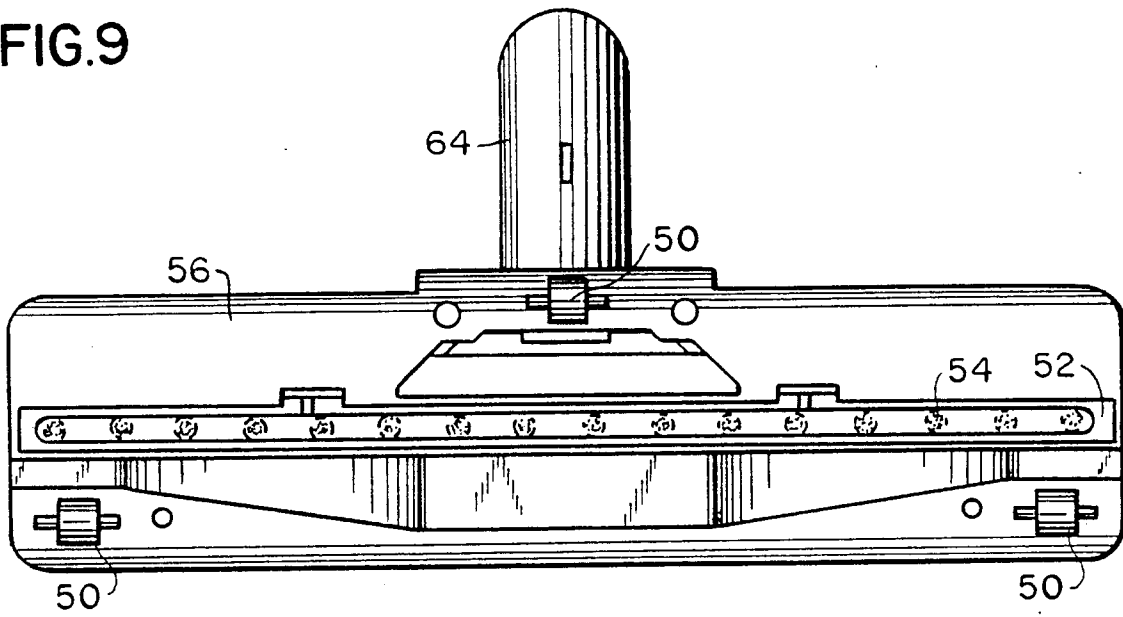

FIG.10

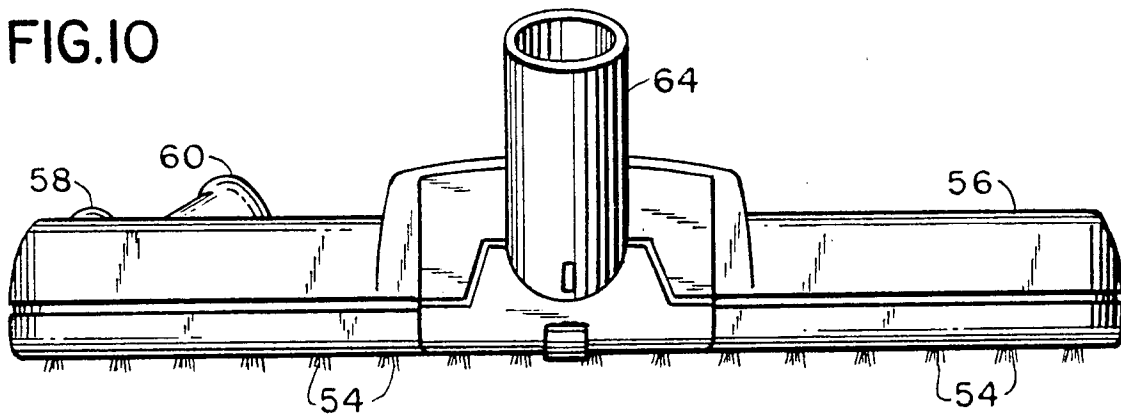

FIG.II

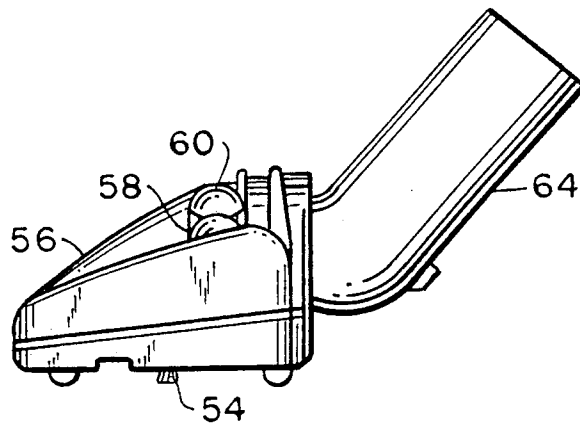

FIG.12

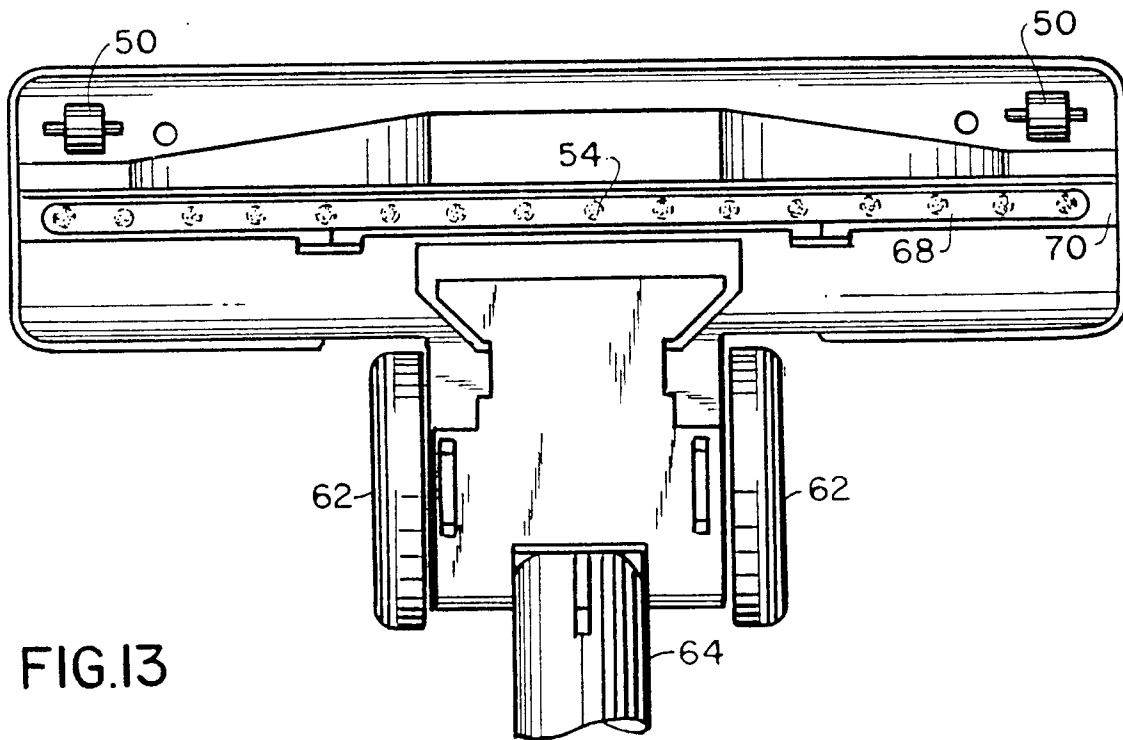
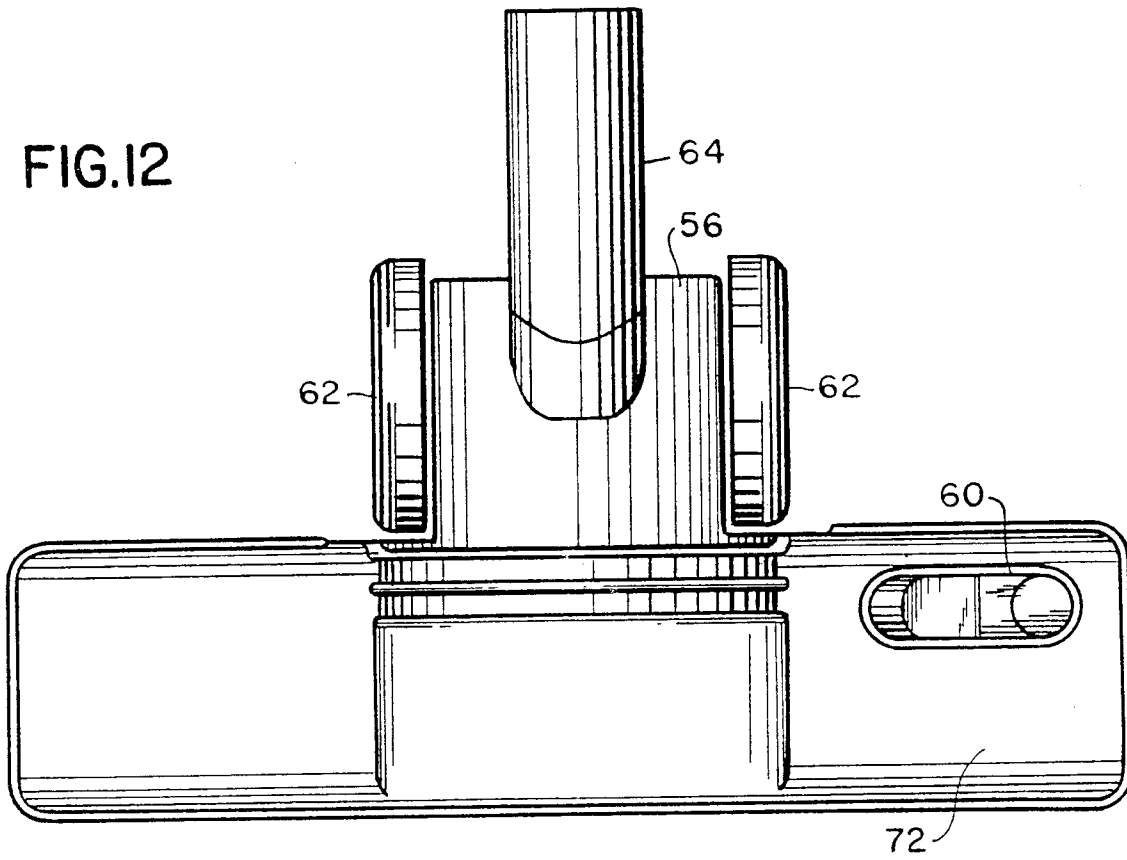

FIG.13

FIG.14

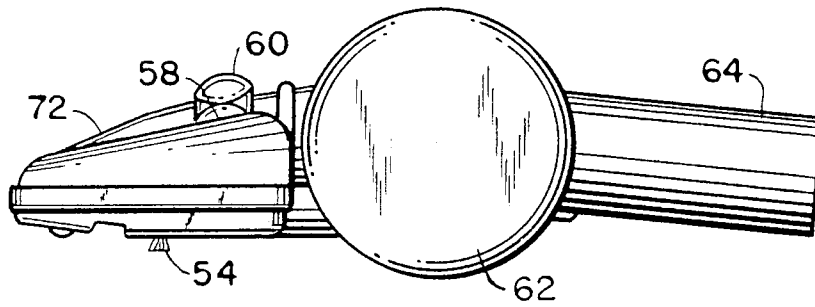
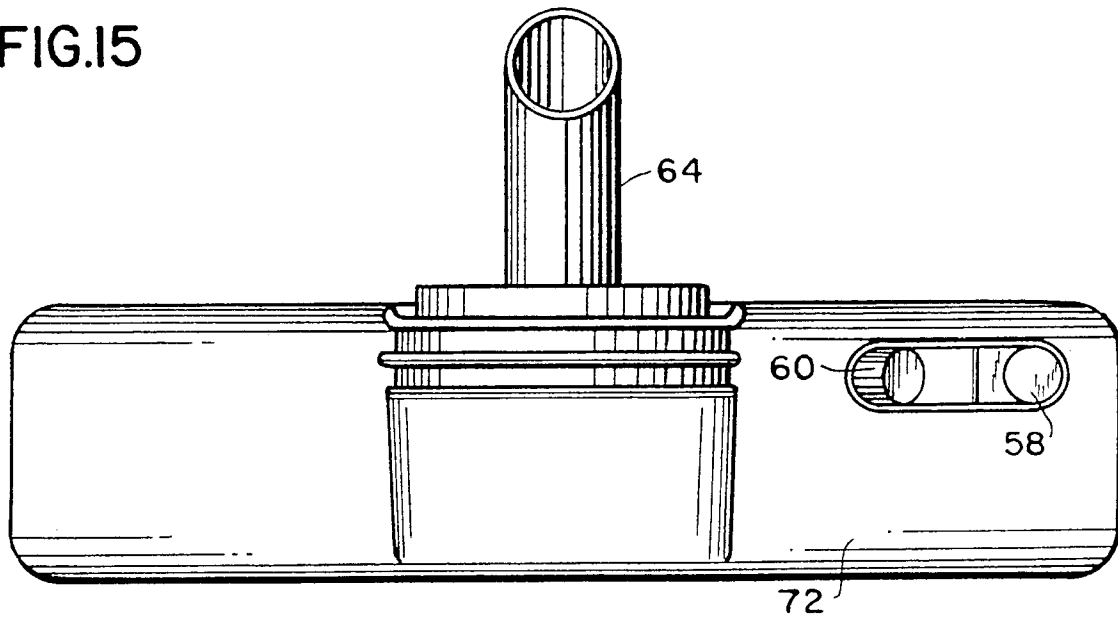

FIG.15



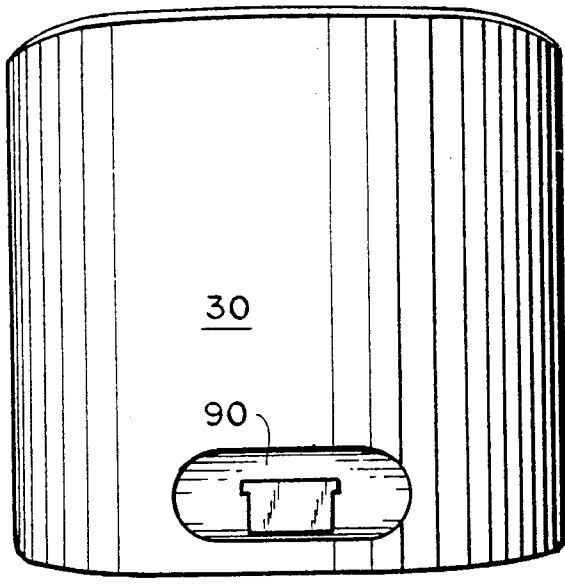

FIG. 17

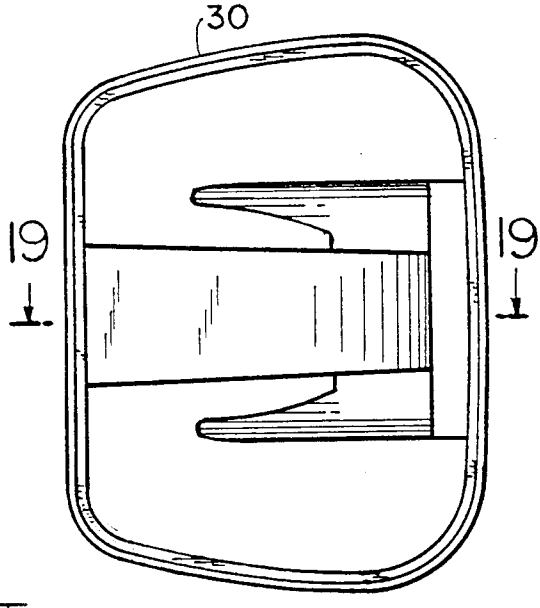

FIG. 16

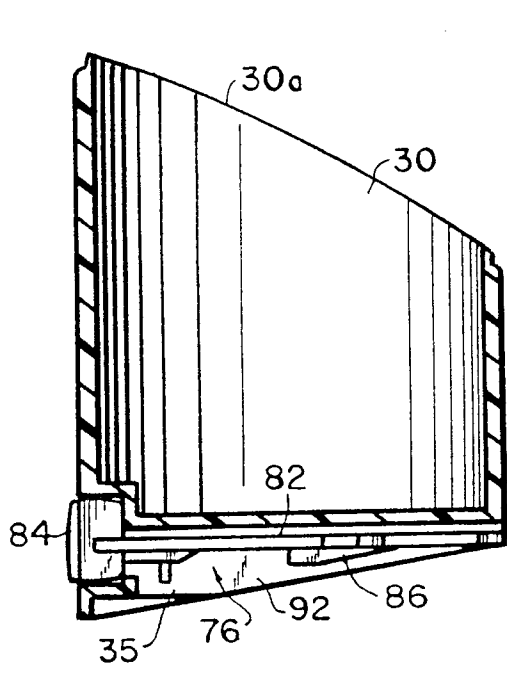

FIG. 19

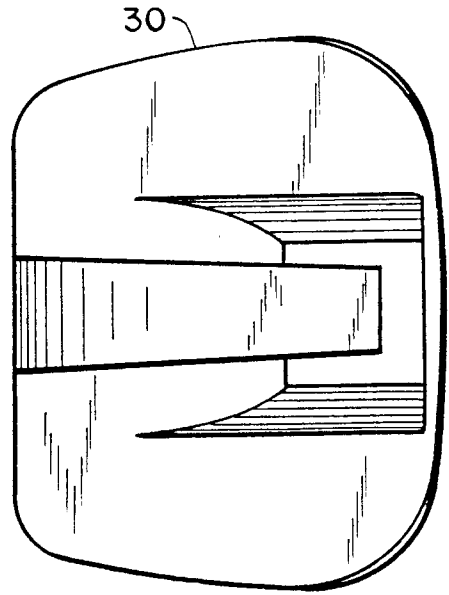

FIG. 18

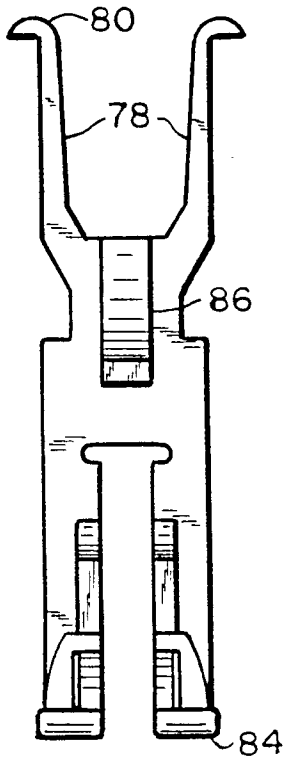

FIG. 20

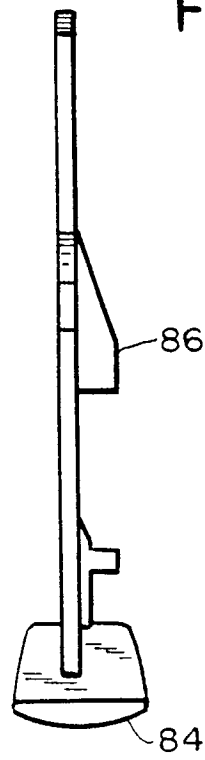

FIG. 21

FIG. 22

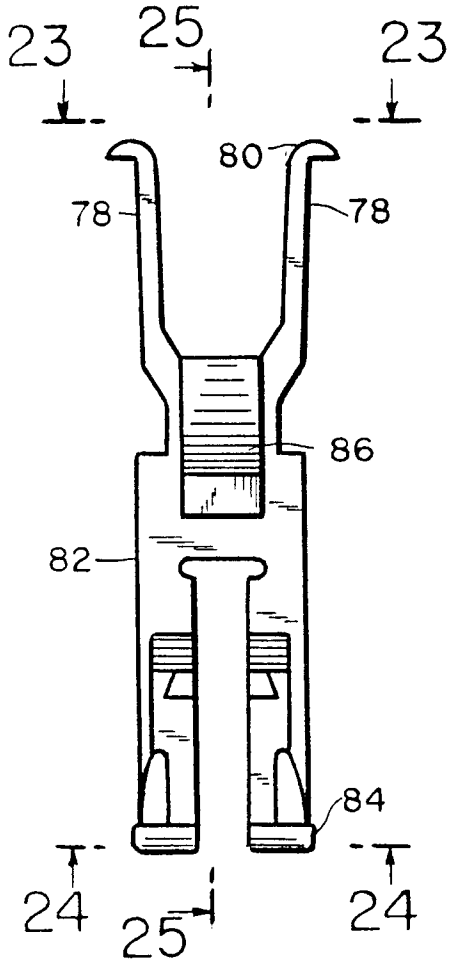

FIG. 23

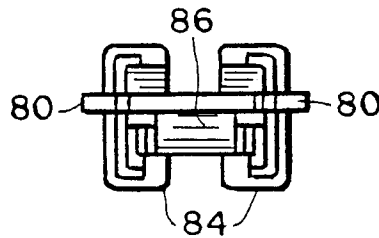

FIG. 25

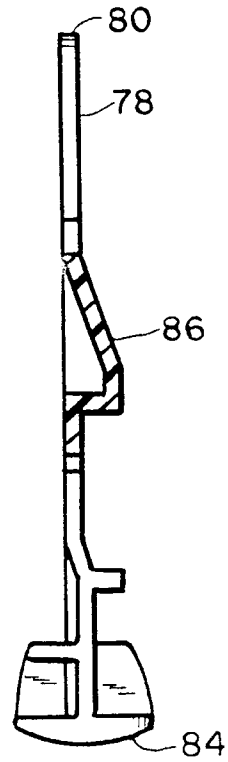

FIG. 24

