



EUROPEAN PATENT SPECIFICATION

(45) Date of publication of patent specification :
17.05.95 Bulletin 95/20

(51) Int. Cl.⁶ : **H01F 3/14, H01F 27/34,**
H01F 38/02

(21) Application number : **91102491.7**

(22) Date of filing : **20.02.91**

(54) **Coil device.**

(30) Priority : **27.02.90 JP 48830/90**
02.10.90 JP 264250/90
02.10.90 JP 264252/90

(43) Date of publication of application :
04.09.91 Bulletin 91/36

(45) Publication of the grant of the patent :
17.05.95 Bulletin 95/20

(84) Designated Contracting States :
DE FR GB NL

(56) References cited :
AU-A- 518 715
DE-A- 3 123 006
FR-A- 1 490 564
US-A- 3 434 085
US-A- 3 566 323
US-A- 3 787 790

(56) References cited :
US-A- 4 282 567
PATENT ABSTRACTS OF JAPAN vol. 4, no.
130 (E-25)(612) 12 September 1980, & JP-A-55
83210 (NIPPON DENSHI K.K.)

(73) Proprietor : **TDK CORPORATION**
13-1, Nihonbashi 1-chome
Chuo-ku Tokyo (JP)

(72) Inventor : **Ito, Shinichiro, c/o TDK Corporation**
13-1 Nihonbashi 1-chome
Chuo-ku, Tokyo (JP)
Inventor : **Kinoshita, Yukiharu, c/o TDK**
Corporation
13-1 Nihonbashi 1-chome
Chuo-ku, Tokyo (JP)

(74) Representative : **Münich, Wilhelm, Dr. et al**
Kanzlei München, Steinmann, Schiller
Wilhelm-Mayr-Str. 11
D-80689 München (DE)

EP 0 444 522 B1

Note : Within nine months from the publication of the mention of the grant of the European patent, any person may give notice to the European Patent Office of opposition to the European patent granted. Notice of opposition shall be filed in a written reasoned statement. It shall not be deemed to have been filed until the opposition fee has been paid (Art. 99(1) European patent convention).

Description

BACKGROUND OF THE INVENTION

5 1. Field of the Invention

The present invention relates to improvements in a coil device for use in a flyback transformer, a switching power transformer, a choke coil or the like and more particularly it relates to improvements in a coil device employing a magnetic core with a gap.

10

2. Description of the Prior Art

In any of the conventional transformers, choke coils and so forth known heretofore, it is customary to form a gap in a closed magnetic path so that the magnetic core thereof is not saturated when a desired current is caused to flow. For example, when a ferrite magnetic core usually having a magnetic permeability μ of 5000 or so is used in a transformer, a gap is formed there to reduce the effective permeability μ within a range of 50 to 300.

This signifies that a gap having a great magnetic reluctance needs to be in existence in a ferrite magnetic core of which magnetic reluctance is originally small, wherein a great leakage flux is generated in the periphery of the gap.

It is generally known that such leakage flux exerts at least two harmful influences as follows.
 (1) Noise is induced in peripheral apparatus (components) which are prone to be effected by magnetic induction.

(2) In case the coil is so wound as to surround the gap, there occurs abnormal generation of heat in the coil around the gap due to the leakage flux.

For the purpose of solving the above problems, a variety of improvements have been developed. In an attempt to settle the problem (1) above, there is contrived a coil device 1' of forming a gap merely in the coil alone. In Fig.17 is illustrated a structure of this conventional type of coil device 1'.

This coil device 1' is constructed such that a sectionally U-shaped first magnetic core 2' is combined with a similarly sectionally U-shaped second magnetic core 3' and then a coil 6' is wound around portions of the magnetic cores 2' and 3'.

The first magnetic 2' and the second magnetic core 3' have legs 2a' and 3a', respectively. The first magnetic core 2' and the second magnetic core 3' are arranged such that the first leg 2a' and the first leg 3a' are oppositely faced to each other via a gap 5'. The coil 6' is wound so as to cover the gap 5' within it. The opposing legs 2a' and 3a' are formed into such a shape as one in which their lateral sectional areas become equal to each other over their entire lengths. As a combination of the magnetic cores, there may be another sectionally E-shaped core.

A B-H curve shown in Fig. 18 shows a data found in the prior art coil device 1'. As shown in this figure, a maximum flux density Bm of the conventional type of coil device 1' is 5510Gs.

Table 1 below indicates a result of measurement of temperatures in a coil center X, a coil end Y, a core Z and a periphery W of the conventional type of the coil device 1' measured by a testing device T' shown in Fig. 16B (Test condition: Frequency 80 kHz, Sine wave of 1.0 A and Ambient temperature of 40°C).

45

Table 1 (°C)

50

	X	Y	Z	W
Structure	Coil center	Coil end	Core	Periphery
Prior Art	107.5	79.0	74.5	44.0

55

As indicated in Table 1, a mere arrangement of the gap 5' only in the coil 6' causes a high temperature of

more than 100°C at the coil center X and further the problem (2) above is expanded more.

As regards the problem (2) above, as already disclosed in Japanese Patent Laid-Open No. 55-77115 and Japanese Utility Model Laid-Open No. 57-130402, this problem is resolved by a method wherein the gap placed within the coil is divided magnetically into a series of plural segments so as to disperse a concentration of leakage magnetic flux. In addition, there are Japanese Utility Model Publication No. 53-53850 and Japanese Utility Model Publication No. 60-7448 in order to resolve the problems (1) and (2) above. These utility models use material as a gap filler of a material having a larger specific permeability than that of air (more than 1), having reduced magnetic reluctance at the gap and which further decreases the leakage magnetic flux.

As described above, in case that the material quality having a greater relative permeability than that of air (more than 1) is arranged within the coil as the gap member, there is a possibility that the problems (1) and (2) above can be improved to a certain degree.

However, even in this case, there remains a problem that a leakage magnetic flux may be concentrated at an interface part between the gap and the magnetic core. In addition, there is a new problem that it is hard to receive such a material which has an appropriate permeability to use it as the gap filling material, a high saturated magnetic flux density and a low magnetic core loss characteristic corresponding to the magnetic core. Due to this fact, this system may generate the following new problem. Namely, the coil wound over the interface part between the gap and the magnetic core may generate heat abnormally. In addition, the gap may also generate heat abnormally due to the loss of magnetic core at the gap filling material. Further, the B-H curve of the magnetic core having the gap filling material therein becomes of non-linear form and if this is used in a transformer, it may produce a deformed wave form. This is the present state that a more effective improvement may not be attained.

Ballast chokes for use with discharge lamps having a variable lamp voltage are known from the AU-A-0 518 715. From this reference it is known that different saturation levels are obtained by giving in the gap non-uniform dimensions. However, such embodiments result in two saturation knees. This characteristic is produced when the extreme end of a magnetic core is narrowed in such a manner that local saturation is intentionally caused.

It is therefore an object of the present invention to provide a coil device capable of resolving the aforesaid problems, reducing influence of noise against the peripheral apparatus (component), reducing a leakage magnetic flux generated around the gap and preventing an abnormal generation of heat in the coil. It is another object of the present invention to provide a coil device whose cost is less expensive and its reliability in operation is improved.

SUMMARY OF THE INVENTION

In order to accomplish the aforesaid objects, the present invention provides a coil device having magnetic cores having gaps at positions opposed to each other at least in a formed magnetic path and a coil wound to include at least one of said gaps characterized in that a shape of at least one of the opposing magnetic cores to form the gaps around which said coil is wound is made as a curve of logarithmic function ranging from its base end part to its extreme end and its extreme end is provided with a flat surface for adjusting the gaps.

The aforesaid magnetic cores may be formed by combining the U-shaped cores or E-shaped cores.

With such an arrangement, no concentration of the leakage magnetic flux is generated at the interface part between the gaps and the end surface of the magnetic core and further no gap filler material is used, resulting in that the magnetic core loss is not produced and the aforesaid objects can be accomplished.

Brief Description of the Drawings

Figs. 1(a) and (b) are a schematic view and a top plan view for showing a first preferred embodiment of the present invention.

Fig. 2 shows a shape of leg forming a gap shown in Fig. 1(a).

Figs. 3(a) and (b) are a schematic view and a top plan view for showing a coil device of a second preferred embodiment of the present invention.

Figs. 4(a) and (b) illustrate a schematic view and a top plan view of a coil device of a third preferred embodiment of the present invention.

Figs. 5(a) and (b) illustrate a schematic view and a top plan view for showing a coil device of a fourth preferred embodiment of the present invention.

Figs. 6(a) and (b) illustrate a schematic view and a top plan view for showing a coil device of a fifth preferred embodiment of the present invention.

Figs. 7(a) and (b) illustrate a schematic view and a top plan view for showing a coil device of a sixth pre-

ferred embodiment of the present invention.

Figs. 8(a) and 8(b) and Fig. 9 are perspective views for showing legs of the device shown in Figs.1 and 3 to 7, respectively.

5 Figs. 10(a) and (b) illustrate a schematic view and a top plan view for showing a coil device of a seventh preferred embodiment of the present invention.

Figs. 11(a) and (b) illustrate a schematic view and a top plan view for showing a coil device of an eighth preferred embodiment of the present invention.

Figs. 12 to 14 are perspective views for showing examples of leg portions in the device shown in Figs.10 and 11.

10 Fig. 15 is a B-H curve diagram for a coil device of the present invention.

Fig. 16(a) is an illustrative view for showing a method for measuring a temperature at each of the portions in a coil device of the present invention.

Fig. 16(b) is an illustrative view for showing a method for measuring a temperature at each of the portions in a coil device of the prior art.

15 Fig. 17 is a schematic view and a top plan view for showing an example of the prior art.

Fig. 18 is a B-H curve diagram for a coil device of the prior art.

Description of the Preferred Embodiments

20 Referring now to the drawings, some preferred embodiments of the present invention will be described.

The coil device 1 of the first preferred embodiment shown in Figs. 1(a) and (b) is constructed such that the sectionally U-shaped first magnetic core 2 is combined with the similarly sectionally U-shaped second magnetic core 3 and then a coil 6 is wound around a part of the magnetic cores 2 and 3.

25 The first magnetic core 2 has a first leg part 2a and a second leg part 2b. The second magnetic core 3 has a first leg part 3a and a second leg part 3b. The first and second magnetic cores 2 and 3 are arranged such that each of the first leg 2a, the first leg 3a, the second leg 2b and the second leg 3b is oppositely faced to each other through gaps 5 and 7, respectively.

The coil 6 is wound so as to cover one of the gaps 5 in it. The first magnetic core 2 and the second magnetic core 3 are made of ferrite, for example.

30 As shown in Fig. 2, a shape of each of the opposing first leg 2a and the first leg 3a around which the coil 6 is wound is formed such that a lateral sectional area of an extreme end B is smaller than a lateral sectional area of a base end A and further it has a curved shape given by a logarithmic function. Such a shape of the extreme end can be expressed by the logarithmic function of the following equation.

$$r_s - r = x_g \ln (X_s/x)$$

35 where,

x: distance from a center O of the gap 5 toward central axes of the legs 2a and 3a

r: distance from the central axes of the legs 2a and 3a toward a radial direction

r_s : radius of a base end A of legs 2a and 3a

X_s : distance from the base end A to the center O of the gap 5

40 x_g : distance from the extreme end B to the center O of the gap 5

The extreme end B of each of the opposing first legs 2a and 3a around which the coil 6 is wound is provided with a core member 4 having a flat surface as shown in Fig. 2. The core member 4 is used for shaving partially the flat surface in parallel when the gap 5 between the legs 2a and 3a is to be adjusted. Even if this flat surface is partially shaved, an area at the extreme end surface is not varied, resulting in that a characteristic of the device is not varied and its adjustment can be carried out. The core member 4 is made of ferrite, for example.

The coil device 10 of the second preferred embodiment shown in Figs. 3(a) and (b) is constructed such that the sectionally U-shaped first magnetic core 12 is combined with the similarly sectionally U-shaped second magnetic core 13 and the coils 6 are wound around a part of the magnetic cores 12 and 13.

50 The first magnetic core 12 has two first legs 2a of the first preferred embodiment device 1, and the second magnetic core 13 has two first legs 3a of the first preferred embodiment device 1. Each of the magnetic cores 12 and 13 is arranged so as to be opposed to each other via the gap 5 in the same manner as that of the first preferred embodiment device 1. The coil 6 is wound in such a way as each of the gaps 5 is covered in it.

55 The coil device 20 of the third preferred embodiment of the present invention shown in Fig. 4 is constructed such that the substantially sectionally U-shaped first magnetic core 22 approximating to a flat plate is combined with the sectionally U-shaped second magnetic core 23 and then the coils 6 are wound around a part of the magnetic core 23.

The first magnetic core 22 has two slight projecting ends 22a and the second magnetic core 23 has the

first two legs 23a having the similar shape as that of the first preferred embodiment device 1. The first and the second magnetic cores 22 and 23 are constructed such that each of the ends 22a and each of the first legs 23a are oppositely faced to each other via gaps 5. The coils 6 are wound around each of the first legs 23a so as to partially cover each of the gaps 5 therein.

5 The coil device 30 of the fourth preferred embodiment of the present invention shown in Fig. 5 is constructed such that the substantially sectionally U-shaped first magnetic core 32 similar to an L-shape is combined with the substantially sectionally U-shaped second magnetic core 33 similar to an L-shape and the coils 6 are wound around a part of each of the magnetic cores 32 and 33.

10 The first magnetic core 32 has a slight projecting end part 32b and the first leg 32a, and the second magnetic core 33 has a slight projecting end 33b and the first leg 33a. The first and the second magnetic cores 32 and 33 are constructed such that each of the end part 32b and the first leg 33a, and each of the end part 33b and the first leg 32a are oppositely arranged to each other via gaps 5. The coils 6 are wound around each of the first legs 32a and 33a to cover each of the gaps 5 partially within them. Each of the legs 32a and 33a is similarly constructed as that of the legs 2a and 3a of the coil device 1 shown in Fig. 1.

15 The coil device 40 of the fifth preferred embodiment of the present invention shown in Fig. 6 is constructed such that the sectionally U-shaped first magnetic core 42 is combined with the sectionally U-shaped second magnetic core 43 and the coils 6 are wound around a part of the magnetic cores 42 and 43.

20 The first magnetic core 42 has the first leg 42a and the second leg 42b. The second magnetic core 43 has the first leg 43a and the second leg 43b longer than the leg 42a and the leg 42b of the first magnetic core 42. The first magnetic core 42 and the second magnetic core 43 are constructed such that each of the first leg 42a and the first leg 43a, and each of the second leg 42b and the second leg 43b are oppositely faced to each other via gaps 5. The coils 6 are wound to cover each of the gaps 5 in them. Each of the legs 42a, 42b, 43a and 43b is similarly constructed as that of the legs 2a and 3a of the coil device 1 shown in Fig. 1.

25 The coil device 50 of the sixth preferred embodiment of the present invention shown in Fig. 7 is constructed such that the legs 42b and 43b shown in Fig. 6 are replaced and then the first magnetic core 52 of substantial U-shaped section similar to an L-shape is combined with the second magnetic core 53 of U-shaped section also similar to an L-shape.

As the aforesaid sectionally U-shaped magnetic core, the magnetic cores shown in Figs. 8(a), 8(b) and 9 are used.

30 The magnetic core 8 shown in Fig. 8(a) is made such that a leg 8b of the magnetic core having no coil 6 wound thereon around is made into a square shape and the other leg 8a is formed into a column. A magnetic core 8' shown in Fig. 8(b) is made such that both legs 8a' and 8b' are made into square shapes and a gap adjusting core member 4' of the leg 8a' around which the coil 6 is wound is formed into a square shape. The magnetic core 9 shown in Fig. 9 is made such that U-shaped square magnetic cores are connected in parallel to each other and one leg 9a is formed into a column. Both of them show a U-shaped section. A practical device is made such that the coils 6 are wound around the column-like legs 8a, 9a or the square leg 8a' while each of the legs having this shape is coupled in pairs, respectively, and each of the figures above shows only one side core. Material for these magnetic cores is ferrite, for example.

40 The coil device 60 of the seventh preferred embodiment of the present invention shown in Fig. 10 is constructed such that the magnetic cores 12 and 13 of the device 10 shown in Fig. 3 are formed into an E-shape. This device 60 is made such that the sectionally E-shaped first magnetic core 62 is coupled with the similarly sectionally E-shaped second magnetic core 63 and the coils 6 are wound around a part of the magnetic cores 62 and 63.

45 The first magnetic core 62 has the first, second and third legs 62a, 62b and 62c, and the second magnetic core 63 has the first, second and third legs 63a, 63b and 63c. The first and second magnetic cores 62 and 63 are constructed such that the first leg 62a and the first leg 63a, the second leg 62b and the second leg 63b, and the third leg 62c and the third leg 63c are oppositely faced to each other via gaps 5, respectively. The coils 6 are wound to cover each of the gaps 5 therein. The legs 62a to 62c and 63a to 63c are similarly constructed as the legs 2a and 3a of the coil device 1 shown in Fig. 1.

50 The coil device 70 of the eighth preferred embodiment of the present invention shown in Fig. 11 is made such that the magnetic cores 2 and 3 of the coil device 1 shown in Fig. 1 are formed into an E-shape. The device 70 is constructed such that the sectionally E-shaped first magnetic core 72 is combined to the second magnetic core 73, and the coil 6 is wound around a part of the magnetic cores 72 and 73.

55 The first magnetic core 72 has the first, second and third legs 72a, 72b and 72c. The first magnetic core 73 has the first, the second and the third legs 73a, 73b and 73c. The first and the second magnetic cores 72 and 73 are arranged such that the first leg 72a and the first leg 73a, the second leg 72b and the second leg 73b, and the third leg 72c and the third leg 73c are oppositely faced to each other via gaps 5 and 7, respectively. The coil 6 is wound so as to cover the central gap 5 therein. Each of the central legs 72b and 73b is similarly

constructed as the legs 2a and 3a of the coil device 1 shown in Fig. 1.

As the aforesaid sectionally E-shaped magnetic core, the magnetic cores shown in Figs. 12 to 14 are used. That is, the magnetic core shown in Fig. 12 is made such that a magnetic core 63' is formed into an E-shape and a central leg 63a' is formed into a column. The magnetic core shown in Fig. 13 is called as a pot-type core 63' in which a column-like leg 63' is formed at a central part of a cylinder having a bottom part. The magnetic core shown in Fig. 14 is made such that a part of the cylinder of the pot-type core shown in Fig. 13 is cut. Any of them has an E-shaped section. Although the practical magnetic cores are combined to each other in pairs and then a coil 6 is wound around the central leg 63a' , each of the above figures shows only one core. As the material for these magnetic cores, for example, a ferrite is applied.

Table 2 indicates a result of temperature measurement in each of the portions in the coil device produced by each of the preferred embodiments through a comparison with the prior art coil device 1'. The temperature measurement at each of the portions was carried out by using the testing device T shown in Fig. 16(a). (Test condition: Frequency of 80 kHz, 1.0A, Sine wave, Ambient temperature of 40 °C)

Table 2

(°C)

	X	Y	Z	W
Structure	Coil center	Coil end	Core	Periphery
1st Preferred Embodiment	62.0	55.0	53.5	41.0
2nd Preferred Embodiment	62.1	54.9	53.7	41.0
3rd Preferred Embodiment	57.0	60.0	50.5	41.0
4th Preferred Embodiment	56.5	61.5	52.0	41.0
5th Preferred Embodiment	58.2	59.1	50.7	41.0
6th Preferred Embodiment	57.2	60.3	51.2	41.0
7th Preferred Embodiment	61.6	55.8	53.8	41.0
8th Preferred Embodiment	61.5	56.0	53.7	41.0
Prior Art	107.5	79.0	74.5	44.0

As apparent from Table 2 above, according to each of the preferred embodiments of the present invention, it is acknowledged that temperatures at the coil center X, coil end Y, core Z and periphery W are lowered than that of the prior art. Accordingly, it is possible to prevent an abnormal generation of heat of the coil. That is, it means that the leakage magnetic flux produced around the gap having the coil wound therearound is reduced. Accordingly, it is further possible to prevent a bad influence of noise against the peripheral apparatus. In addition, the assembling operation may easily be carried out, resulting in that a cost reduction of the device can be attained.

It is further apparent that although the maximum magnetic flux density Bm of the coil device in each of the preferred embodiments of the present invention was 5510 Gs in the prior art as shown in the B-H curve in Fig. 15, this value is slightly decreased to 5480 Gs and its linear characteristic is not varied. Since the area

keeping its linear characteristic is almost invariant, there is no obstacle in practical operation even if the density B_m is decreased to such a value as above.

5 Claims

1. A coil device (1,10,20,30,40,50,60,70) including two magnetic cores (2,3,12,13,22,23,32,33,42,43,52,53,8,8',9,62,63,72,73) having legs (2a,2b,3a,3b,23a,32a,33a,42a, 42b,43a,43b,8a,8a',9a,62a,62b,62c,63a,63b,63c,72a,72b, 72c,73a,73b,73c) oppositely faced to each other through gaps (5,7) to form a magnetic path, and at least one coil (6), each coil (6) being wound to cover at least partially one of said gaps (5,7),
characterized in that:
 the end-portion of each leg (2a,2b,3a,3b,23a,32a,33a,42a, 42b,43a,43b,8a,8a',9a,62a,62b,62c,63a,63b,63c,72a,72b,72c, 73a,73b,73c) around which a coil (6) is wound has its cross-sectional area progressively reduced towards the gap (5,7) so as to have a shape made as a curve of logarithmic function, and in that the ends of the said coil-wound legs are provided with a projection for adjusting the gap (5,7), said projection having a uniform cross-sectional area from its base to its forward end.
2. A coil device (1,10,20,30,40,50,60,70) according to claim 1 in which said magnetic cores (2,3,12,13,22,23,32, 33,42,43,52,53,8,8',9,62,63,72,73) are U-shaped.
3. A coil device (1,10,20,30,40,50,60,70) according to claim 1 in which said magnetic cores (2,3,12,13,22,23,32,33,42,43,52,53,8,8',9,62,63,72,73) are E-shaped.

25 Patentansprüche

1. Spulenordnung (1, 10, 20, 30, 40, 50, 60, 70) mit zwei Magnetkernen (2, 3, 12, 13, 22, 23, 32, 33, 42, 43, 52, 53, 8, 8', 9, 62, 63, 72, 73) mit Schenkeln (2a, 2b, 3a, 3b, 23a, 32a, 33a, 42a, 42b, 43a, 43b, 8a, 8a', 9a, 62a, 62b, 62c, 63a, 63b, 63c, 72a, 72b, 72c, 73a, 73b 73c), die sich unter Bildung einer magnetischen Bahn über Spalte (5, 7) einander gegenüberstehen, und mit mindestens einer Spule (6), wobei jede Spule (6) so gewickelt ist, daß sie zumindest teilweise einen der Spalte (5, 7) überdeckt,
dadurch gekennzeichnet, daß der Endabschnitt jedes Schenkels (2a, 2b, 3a, 3b, 23a, 32a, 33a, 42a, 42b, 43a, 43b, 8a, 8a', 9a, 62a, 62b, 62c, 63a, 63b, 63c, 72a, 72b, 72c, 73a, 73b 73c), um den eine Spule (6) gewickelt ist, eine sich zum Spalt (5, 7) hin zunehmend so verringernde Querschnittsfläche aufweist daß sich eine Form ergibt, die als Kurve einer logarithmischen Funktion ausgebildet ist, und daß die Enden der von der Spule umwickelten Schenkel mit einem Vorsprung zum Einstellen des Spalts (5, 7) ausgebildet sind, wobei der Vorsprung von seinem Ansatz bis zu seinem vorderen Ende eine gleichmäßige Querschnittsfläche aufweist.
2. Spulenordnung (1, 10, 20, 30, 40, 50, 60, 70) nach Anspruch 1, bei welcher die Magnetkerne (2, 3, 12, 13, 22, 23, 32, 33, 42, 43, 52, 53, 8, 8', 9, 62, 63, 72, 73) U-förmig sind.
3. Spulenordnung (1, 10, 20, 30, 40, 50, 60, 70) nach Anspruch 1, bei welcher die Magnetkerne (2, 3, 12, 13, 22, 23, 32, 33, 42, 43, 52, 53, 8, 8', 9, 62, 63, 72, 73) E-förmig sind.

Revendications

1. Dispositif de bobine (1, 10, 20, 30, 40, 50, 60, 70) à deux noyaux magnétiques (2, 3, 12, 13, 22, 23, 32, 33, 42, 43, 52, 53, 8, 8', 9, 62, 63, 72, 73) à des branches (2a, 2b, 3a, 3b, 23a, 32a, 33a, 42a, 42b, 43a, 43b, 8a, 8a', 9a, 62a, 62b, 62c, 63a, 63b, 63c, 72a, 72b, 72c, 73a, 73b 73c) qui font face l'une à l'autre à travers des entrefers (5, 7), en formant un espace magnétique, ainsi qu'à au moins une bobine (6), chacune des bobines (6) étant enroulée de façon à couvrir, au moins en partie, un desdits entrefers (5, 7),
caractérisé en ce que la partie d'extrémité de chacune desdites branches (2a, 2b, 3a, 3b, 23a, 32a, 33a, 42a, 42b, 43a, 43b, 8a, 8a', 9a, 62a, 62b, 62c, 63a, 63b, 63c, 72a, 72b, 72c, 73a, 73b 73c), autour de laquelle est enroulée une bobine (6), a une aire de section transversale qui est progressivement réduite vers ledit entrefer (5, 7) de façon à engendrer une forme définie comme la courbe d'une fonction loga-

rithmique, et en ce que les extrémités des branches enroulées par ladite bobine sont réalisées à une partie en saillie afin d'ajuster ledit entrefer (5, 7), laquelle partie en saillie présente, à partir de sa base jusqu'à son extrémité avant, une aire de section transversale homogène.

- 5 **2.** Dispositif de bobine (1, 10, 20, 30, 40, 50, 60, 70) selon la revendication 1, dans lequel lesdits noyaux magnétiques (2, 3, 12, 13, 22, 23, 32, 33, 42, 43, 52, 53, 8, 8', 9, 62, 63, 72, 73) ont une forme en U.
- 3.** Dispositif de bobine (1, 10, 20, 30, 40, 50, 60, 70) selon la revendication 1, dans lequel lesdits noyaux magnétiques (2, 3, 12, 13, 22, 23, 32, 33, 42, 43, 52, 53, 8, 8', 9, 62, 63, 72, 73) ont une forme en E.

10

15

20

25

30

35

40

45

50

55

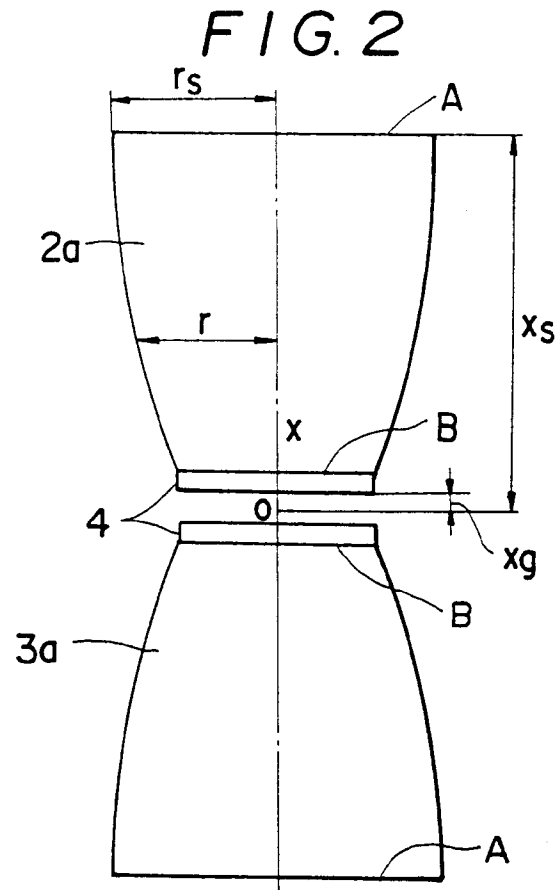
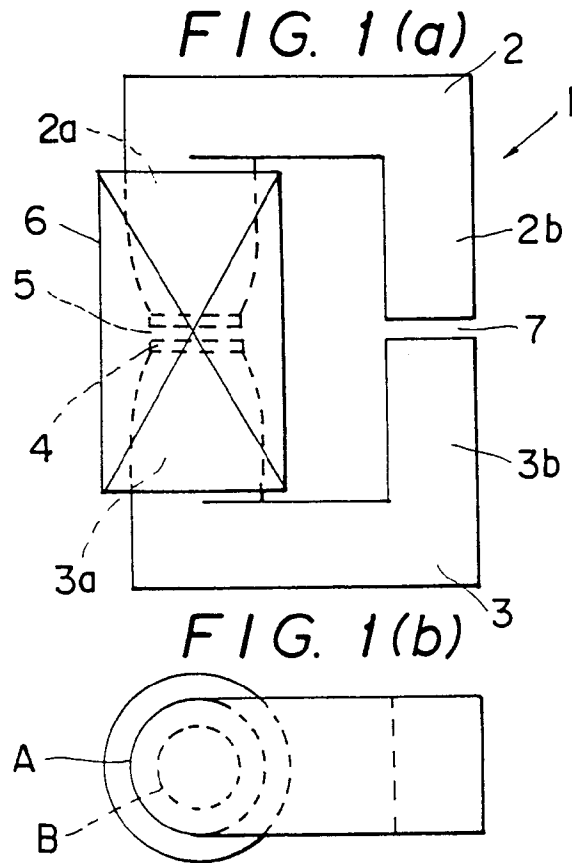

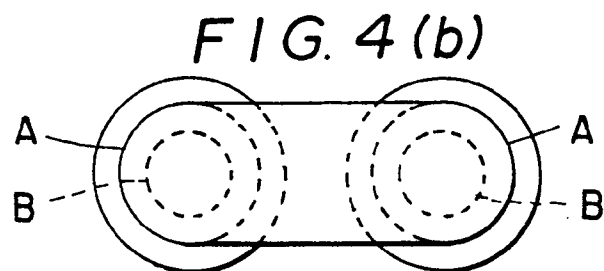
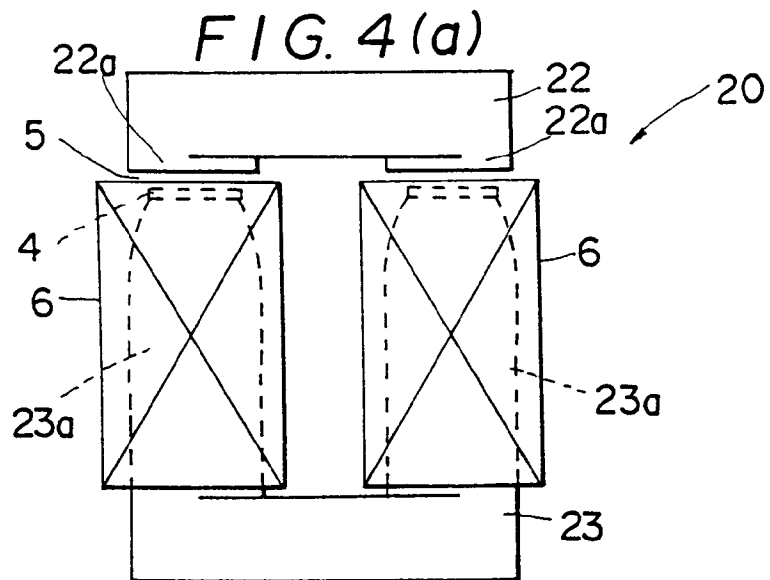
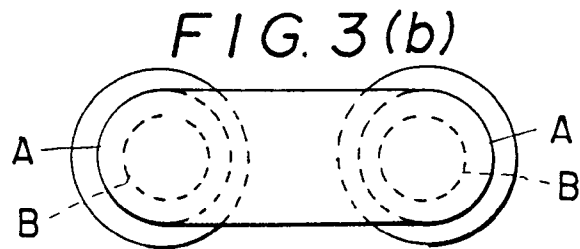
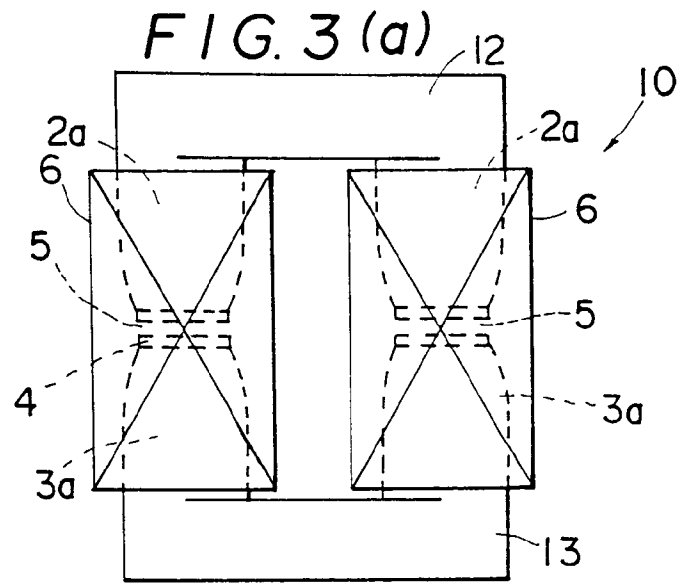

FIG. 5 (a)

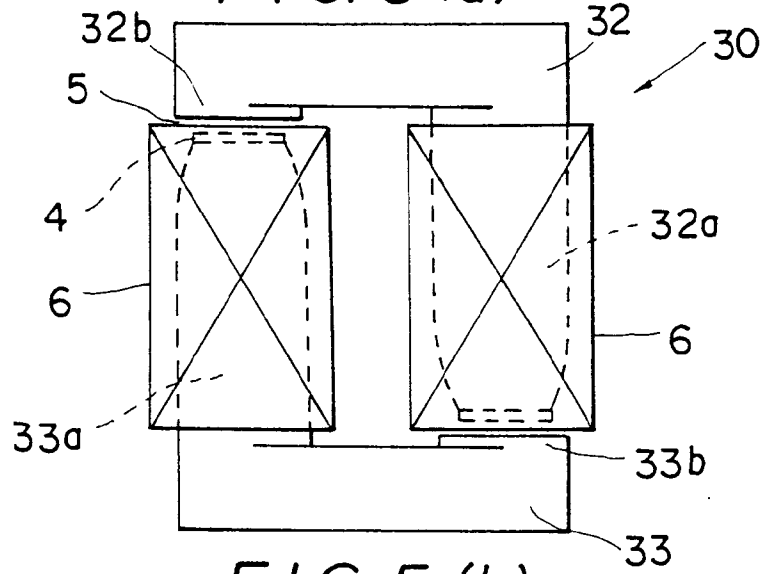

FIG. 5 (b)

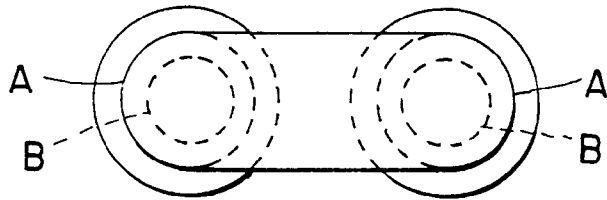

FIG. 6 (a)

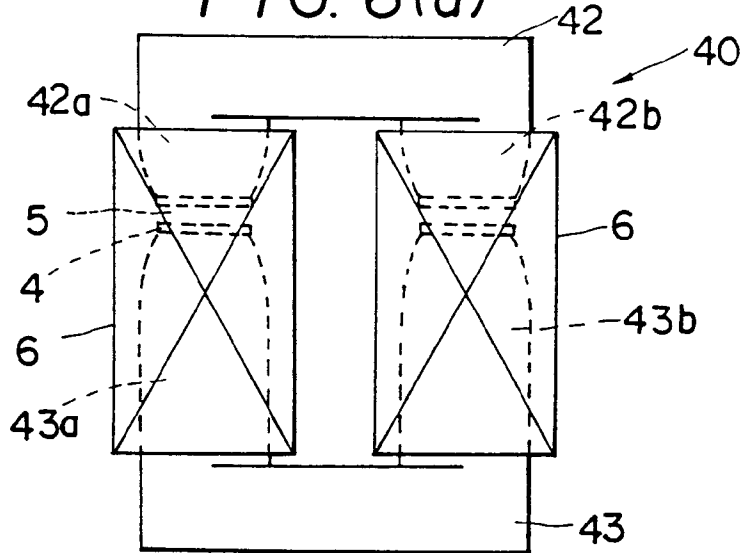

FIG. 6 (b)

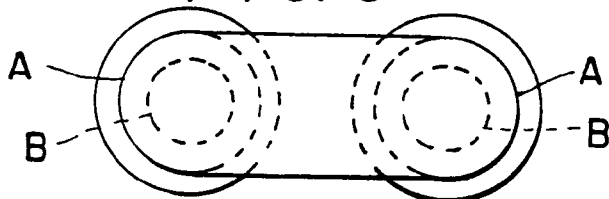

FIG. 7 (a)

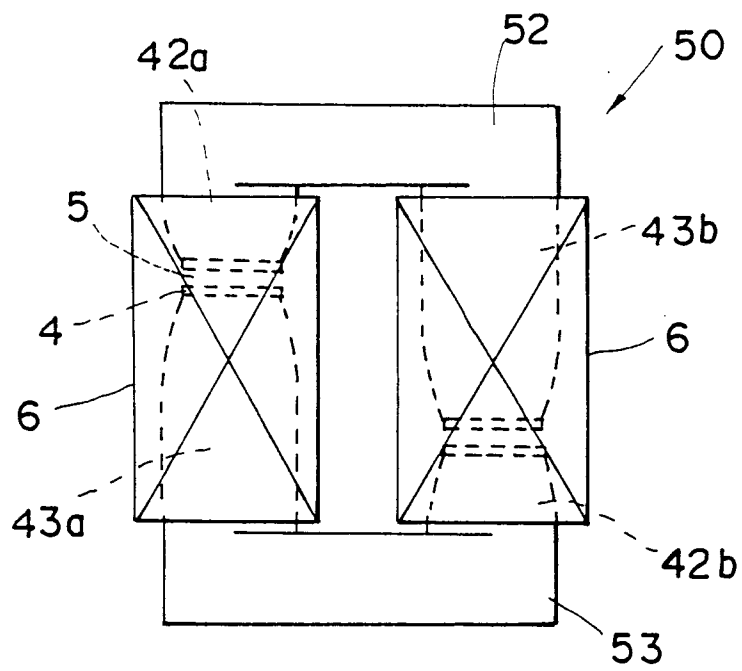

FIG. 7 (b)

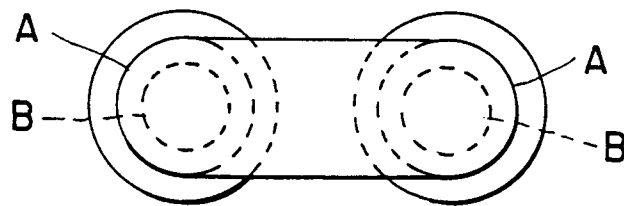

FIG. 8 (a)

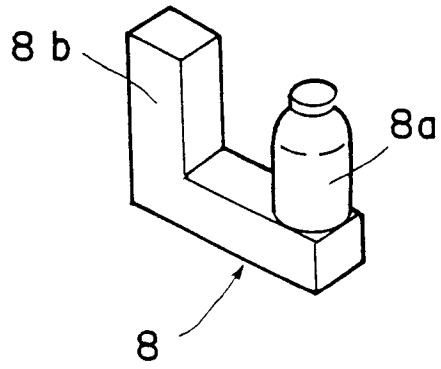

FIG. 8 (b)

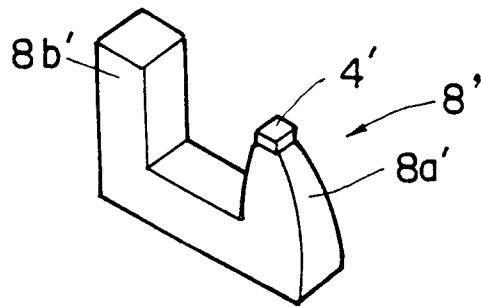
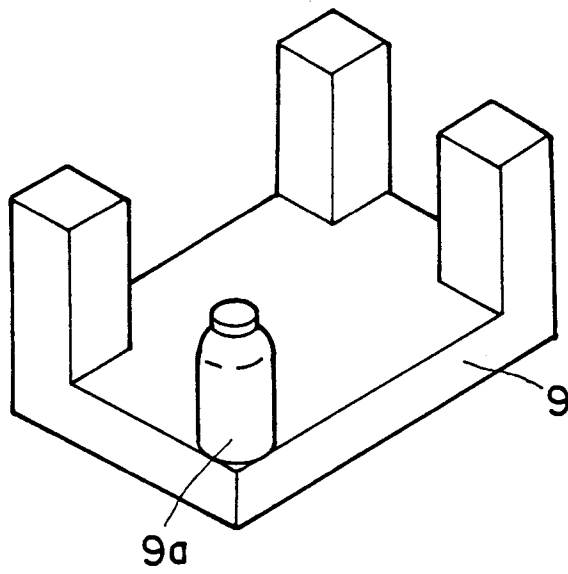

FIG. 9



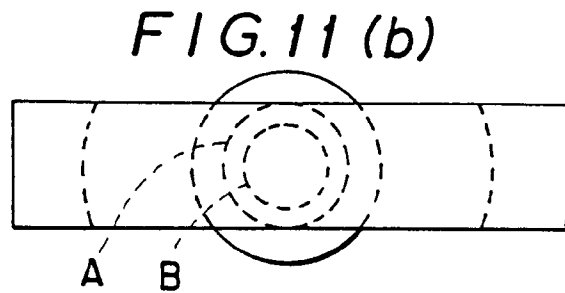
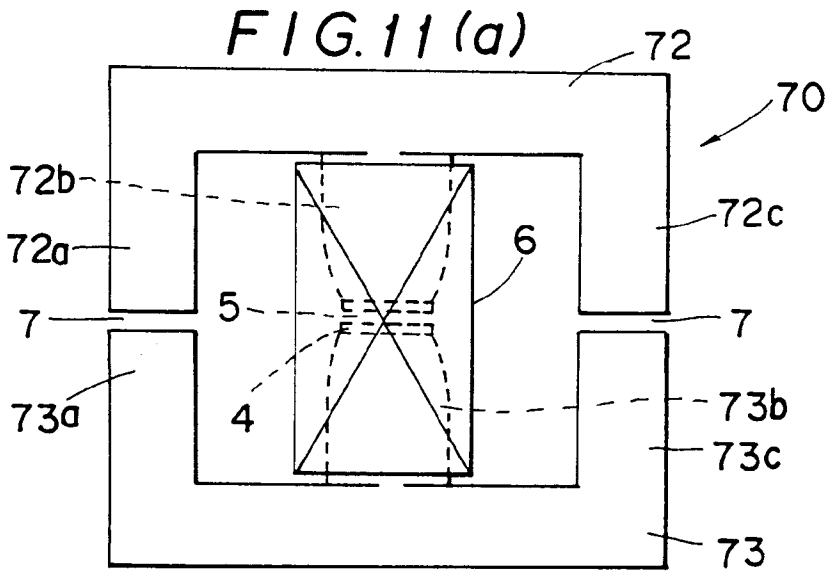
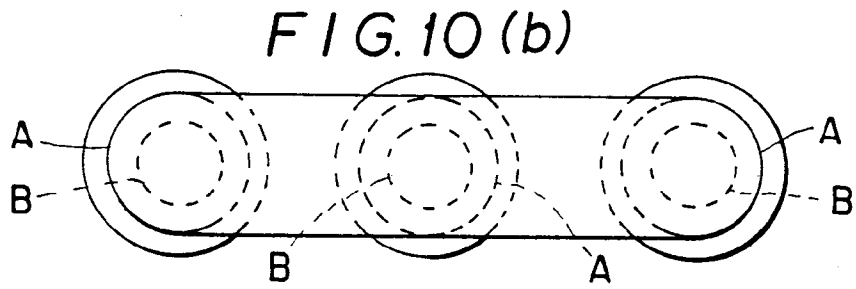
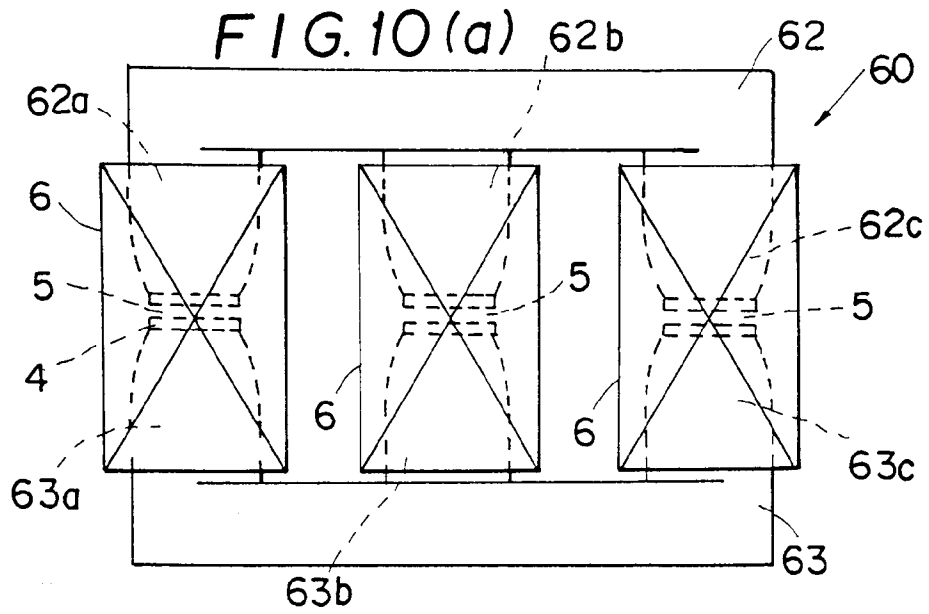

FIG. 12

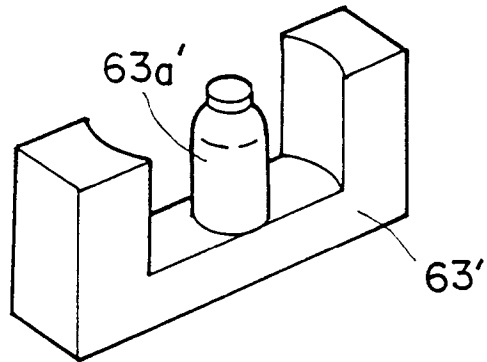

FIG. 13

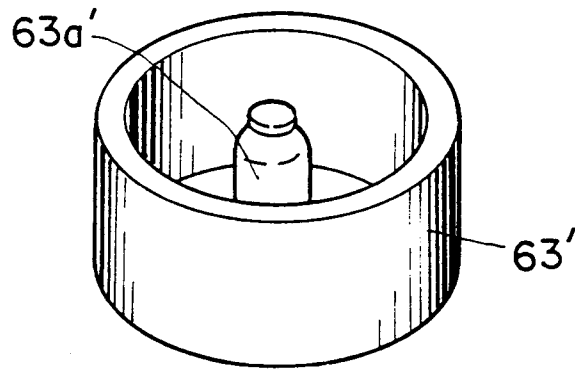

FIG. 14

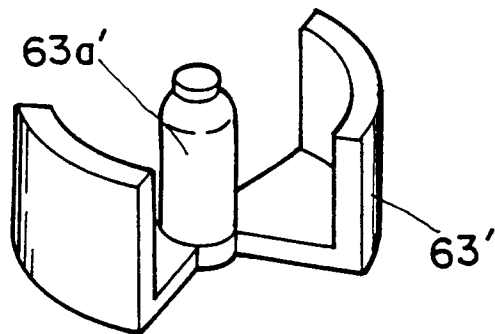

FIG. 15

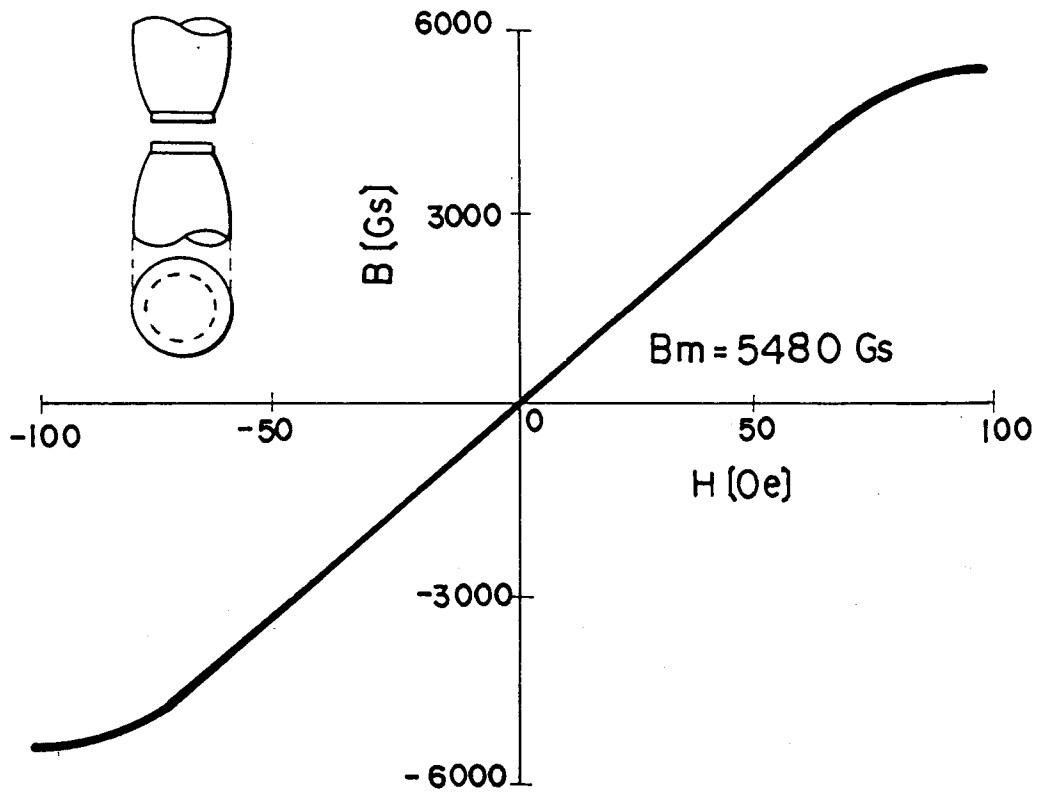

FIG.16 (a)

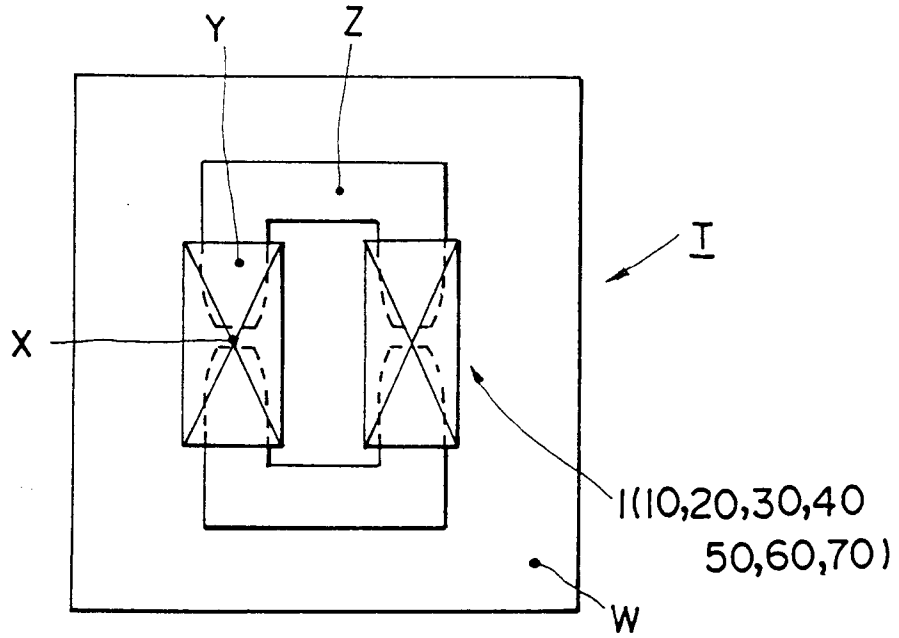

FIG.16 (b)

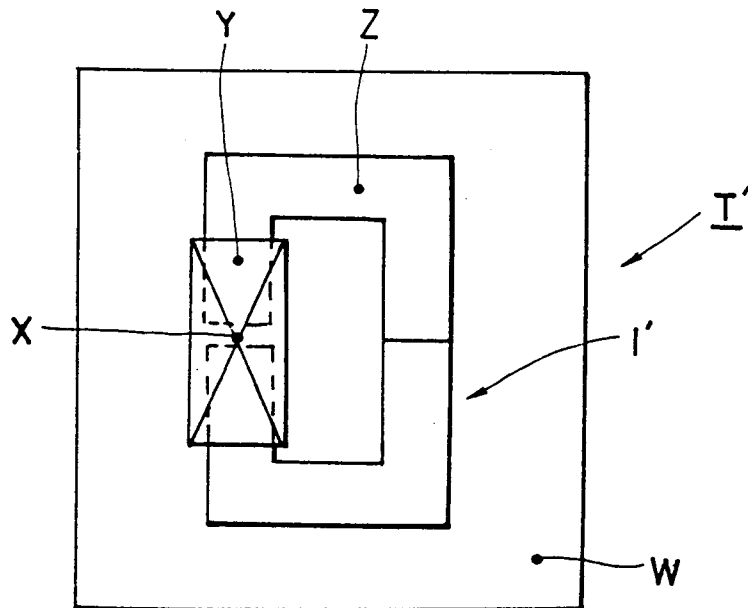

FIG.17

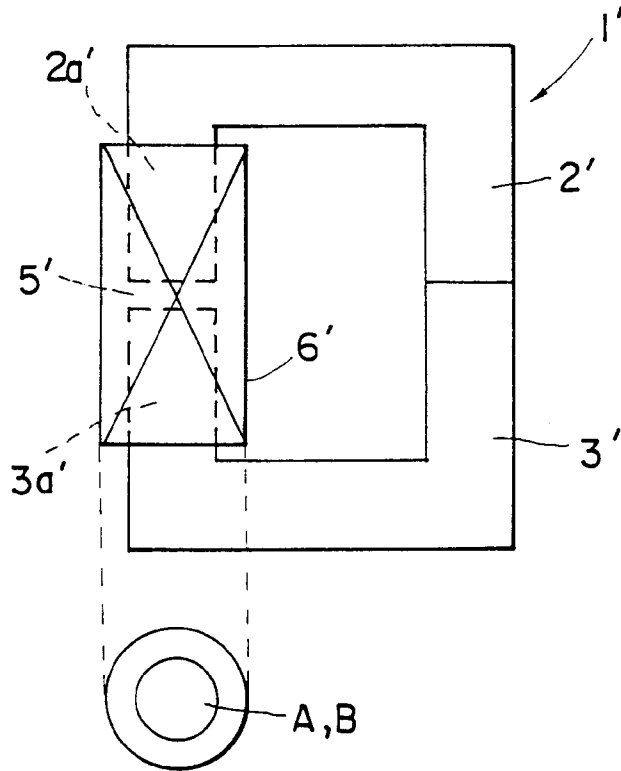

FIG.18

