



12 **EUROPEAN PATENT SPECIFICATION**

45 Date of publication of patent specification :
05.10.94 Bulletin 94/40

51 Int. Cl.⁵ : **H01R 13/11**

21 Application number : **89912351.7**

22 Date of filing : **30.10.89**

86 International application number :
PCT/US89/04793

87 International publication number :
WO 90/06602 14.06.90 Gazette 90/14

54 **ELECTRICAL CONTACT.**

30 Priority : **30.11.88 JP 156292/88 U**

43 Date of publication of application :
18.09.91 Bulletin 91/38

45 Publication of the grant of the patent :
05.10.94 Bulletin 94/40

84 Designated Contracting States :
DE FR GB IT NL

56 References cited :
DE-A- 1 465 126
DE-A- 3 105 429
GB-A- 1 571 544
JP-Y- 604 394

73 Proprietor : **THE WHITAKER CORPORATION**
Suite 450,
4550 New Linden Hill Road
Wilmington, Delaware 19808 (US)

72 Inventor : **KIKUCHI, Shoji**
43-4, Sengokugashi
Hiratsuka-shi
Kanagawa (JP)
Inventor : **ONOUE, Nobuaki**
9-2-604, Kami-tsuruma 7-chome
Sagamihara-shi
Kanagawa (JP)

74 Representative : **Klunker . Schmitt-Nilson .**
Hirsch
Winzererstrasse 106
D-80797 München (DE)

EP 0 446 220 B1

Note : Within nine months from the publication of the mention of the grant of the European patent, any person may give notice to the European Patent Office of opposition to the European patent granted. Notice of opposition shall be filed in a written reasoned statement. It shall not be deemed to have been filed until the opposition fee has been paid (Art. 99(1) European patent convention).

Description

The present invention relates to an electrical connector according to the preamble of the claim. Its electrical contact may be made by stamping and forming an electrically-conductive metal plate.

One example of such contact is a receptacle contact having a contact section for electrical connection with a section of a mating complementary plug contact between a conductor-crimping section and an insulation cover-crimping section at one side and also an engaging member in the form of a lance to prevent the contact from slipping out after being inserted in an insulation housing as disclosed in the specification of Japanese Utility Patent Publication No. 4394/85.

This known contact provides sufficient distance between the conductor-crimping section and the insulation cover-crimping section, thereby overcoming disadvantages associated with a shorter length, i.e., possible cutting of the conductor in the wire-crimping operation and improper electrical contact with the wire conductor. In this way, the electrical connection operation is made easier and the height of the insulation housing to hold the contact is reduced.

The conventional engaging member in the form of a lance is made by cutting and forming outwardly the side edges of the section at the side of the insulation cover-crimping section, thereby providing resiliency of the engaging member. In order to maintain the contact having such an engaging member in the insulation housing, the contact is inserted in a cavity of the insulation housing at one or upper opening end and the engaging member is pushed inwardly by the inner wall of the cavity against its resiliency. Simultaneously, a fixed step portion formed on the one side wall of the cavity releases the inward pushing so that a tip of the engaging member is engaged with the step portion, thereby providing the contact with lance means in the direction opposite to the insertion thereof.

However, the engaging member is made by forming outwardly a relatively thin metal member, and thus insufficient in strength. It may also be bent or deformed when pulled in the opposite direction with a relatively strong force, thus, it may be broken due to metal fatigue when it is frequently inserted in and extracted from the insulation housing, i.e., when the number of insertions and extractions increases. Also, since the engaging member forms a substantially V-shaped gap with the side edge of the contact, such engaging member tends to catch and scratch wires and the engaging member may be deformed, especially when handling electrical wires having a plurality of contacts connected thereto. If a shorter engaging member is used to avoid such problems, the resiliency will be ineffective for proper engagement with the fixed step portion.

It is, therefore, an object of this invention to over-

come the aforementioned disadvantages of the conventional contact.

This object is achieved by an electrical connector as defined in the claim.

In a preferred embodiment of the invention, the engaging member is formed by forming an outward projection in a part of the securing member at one side edge at the insulation cover-crimping section side of the securing member.

In the preferred embodiment of the present invention, the engaging member is formed outwardly from the opposite side edge of the securing member toward the one side edge.

The contact, as formed above, is inserted in the cavity of the insulation housing against the resiliency of the resilient lance formed as a part of a side wall of the cavity. The engaging member is pressed inwardly and then overrides one end of the housing lance until it is brought into an engaged condition therewith. In this way, the contact is secured in the reverse direction to the insertion direction thereof. The electrical contact section is electrically connected with a complementary mating contact secured in a separate insulation housing.

Resilient lances formed in an insulation housing for securing electrical contacts in contact receiving cavities of the insulation housing are known per se from US-A- 4 690 477 and GB-A- 1 571 544. In both cases, the resilient lance resiliently engages a shoulder limiting a recess formed between a crimping section end and a mating end of an electrical contact inserted in the cavity of the insulation housing.

The contact according to the present invention will be described in detail by way of example hereunder with reference to the accompanying drawings.

Fig. 1 is a perspective view of one embodiment of the contact according to this invention crimped to an electric wire;

Fig. 2 is a top plan view of Fig. 1;

Fig. 3 is a side elevational view of Fig. 1;

Fig. 4 is a view taken along line 4-4 of Fig. 3 showing the engaging member on the securing member;

Fig. 5 is a perspective view of a connector including a dielectric housing securing the contact crimped to an electric wire shown in Figs. 1 through 3 therein; and

Fig. 6 is a cross-sectional view of the connector of Fig. 5 mated with another connector with the receptacle contact section of the former electrically connected with the pin contact section of the later.

In Figs. 1 through 4, receptacle contact 10 is made from an electrically-conductive metal sheet by conventional stamping and forming techniques. Contact 10 formed in this manner comprises crimping section 11 for conductor core 20a of electric wire 20, crimping section 12 for insulation 20b of wire 20, elec-

trical receptacle contact section 13 for electrical connection with pin contact section 41 (see Fig. 6) of complementary mating contact 40 described hereinafter, and securing member 14 having engaging member 15 for engagement with insulation housing 30 (see Figs. 5 and 6) described hereinafter.

Conductor core-crimping section 11 comprises a pair of crimping members 11a, 11b extending to both sides at one end of contact 10. Both crimping members are bent inwardly to crimp conductor core 20a positioned therebetween. Insulation cover-crimping section 12 comprises a pair of crimping members 12a, 12b extending to both sides at the other end of contact 10 which are crimped onto insulation cover 20b positioned between crimping members 12a, 12b by bending them inwardly. Contact section 13 comprises a pair of contact members 13a, 13b extending from one side between both crimping sections 11, 12 and bent upwardly and inwardly in substantially an inverted L-shape and contact member 13c extending from one side between both contact members 13a, 13b and bent upwardly and outwardly in an inverted L-shape. Securing member 14 extends from the other side between both crimping sections 11, 12 and is bent upwardly in substantially an inverted L-shape. Engaging member 15 is a projection and is made by deforming outwardly a portion of one side edge 14a of member 14 facing insulation cover-crimping section 12. As shown in Fig. 2, engaging member 15 takes a form to gradually protrude from the other side edge 14b to the one side edge 14a of member 14 in an arcuate configuration. It is also arcuate along the one side edge 14a and in vertical cross section as clearly shown in Fig. 4. The engaging member 15 is therefore very large in mechanical strength and provides very smooth sliding against the inner wall surface of a cavity of the housing. Engaging member 15 is preferably arcuate as mentioned above. It may not necessarily be arcuate but may be, for example, polygonal as long as it protrudes gradually from the other side edge 14b to the one side edge 14a of member 14.

Referring now to Figs. 5 and 6, an electrical connector is shown having contact 10 secured in insulation housing 30. Housing 30 is molded from a suitable dielectric material and has a plurality of cavities 31 and a plurality of resilient lances 34 made by forming open section 33a and slots 33b in a side wall 32, lances 34 constituting one side wall of each cavity. Each lance 34 has a progressively-increased thickness from the upper end toward the bottom of cavity 31 and has a raised portion 35 at the inner end. Housing 30 also has a cavity 36 at one side of each cavity 31.

Contact 10 is inserted into cavity 31 from the upper end of housing 30 while engaging member 15 slides along the inner surface of lance 34 against its resiliency to push the lance 34 outwardly. When engaging member 15 overrides raised portion 35, resiliency of the lance 34 allows it to return to the initial

position to stop it within open section 33a. Therefore, the engagement between engaging member 15 and lance 34 will secure contact 10 in this position even if it is pulled upwardly. Such electrical connector having contact 10 secured in cavity 31 may be mated with another electrical connector having a complementary contact 40 secured in insulation housing 50. The mating effects electrical engagement between pin contact section 41 of contact 40 and box-shaped contact section 13 (see Fig. 1) comprising contact members 13a, 13b, 13c by way of cavity 36 as shown in Fig. 6.

According to the contact of an electrical connector of the present invention, an engaging member is formed as a raised section at one side edge of a member positioned between the conductor and insulation cover-crimping sections. The raised engaging member is immovable with respect to the member from which it is formed; thus, it is strong enough not to deform or break when the contact is pulled in the opposite direction to the insertion of the contact when it is secured in the cavity of the insulation housing. The contact according to the present invention solves all the problems mentioned hereinbefore associated with the conventional contact.

In addition, the engaging member of the present invention is made by simply pressing outwardly a part of the member from which it is formed from the inside to the outside thereof. No additional material is needed to form such engaging member, thereby reducing the total length of the contact and making of such contact is done more easily at a lower cost.

Claims

1. An electrical connector comprising:
 - an insulation housing (20) having at least one cavity (31), one wall of the housing (30) forming the cavity (31) including an inwardly-directed raised portion (35) adjacent an inner end;
 - an electrical contact (10) including a conductor crimping section (11) at a first end and an insulation-crimping section (12) at a second end of the contact (10) for respectively crimping to a conductor (20a) and insulation (20b) of an electrical wire (20), a securing member (14) having an engaging member (15) for engagement with said raised portion (35) when the contact (10) is inserted into the cavity (31) to retain the contact (10) therein, and a contact section (13) for electrical connection with a complementary contact (40), said securing member (14) and said contact section (13) being positioned between the conductor and insulation crimping sections (11, 12);
 - characterized in that said raised portion (35) is provided on a resilient lance (34) included in said one wall and in that said engaging member (15) is made by deforming outwardly a portion of one

side edge (14a) of the securing member (14) in an arcuate or polygonal configuration.

Patentansprüche

1. Elektrischer Verbinder mit:
 einem Isoliergehäuse (20) mit wenigstens einem Hohlraum (31), wobei eine den Hohlraum (31) bildende Wand des Gehäuses (30) angrenzend an ein inneres Ende einen nach innen gerichteten erhöhten Bereich (35) aufweist; einem elektrischen Kontakt (10) mit einem Leiter-Crimpabschnitt (11) an einem ersten Ende und einem Isolierungs-Crimpabschnitt (12) an einem zweiten Ende des Kontakts (10) zum Crimpen auf einen Leiter (20a) bzw. auf die Isolierung (20b) eines elektrischen Drahts (20), mit einem Befestigungselement (14), das ein Eingriffselement (15) für den Eingriff mit dem erhöhten Bereich (35) bei in den Hohlraum (31) eingeführtem Kontakt (10) zum Festhalten des Kontakts (10) in diesem aufweist, und mit einem Kontaktabschnitt (13) zur elektrischen Verbindung mit einem komplementären Kontakt (40), wobei das Befestigungselement (14) und der Kontaktabschnitt (13) zwischen dem Leiter- und dem Isolierungs-Crimpabschnitt (11, 12) positioniert sind; dadurch gekennzeichnet, daß der erhöhte Bereich (35) an einer in der genannten einen Wand beinhalteten, federnd nachgiebigen Zunge (34) vorgesehen ist, und daß das Eingriffselement (15) durch nach außen Formen eines Bereichs eines seitlichen Rands (14a) des Befestigungselements (14) in einer bogenförmig gekrümmten oder polygonalen Konfiguration gebildet ist.

Revendications

1. Connecteur électrique comportant :
 un boîtier isolant (20) ayant au moins une cavité (31), une première paroi du boîtier (30) qui forme la cavité (31) comprenant une partie surélevée (35) dirigée vers l'intérieur adjacente à une extrémité intérieure ;
 un contact électrique (10) comprenant une section (11) de sertissage sur un conducteur à une première extrémité et une section (12) de sertissage sur un isolant à une seconde extrémité du contact (10), destinées à être serties, respectivement, sur un conducteur (20a) et un isolant (20b) d'un fil électrique (20), un élément de fixation (14) ayant un élément d'engagement (15) destiné à engager ladite partie surélevée (35) lorsque le contact (10) est inséré dans la cavité (31) pour y retenir le contact (10), et une section (13) de contact pour une connexion électrique

avec un contact complémentaire (40), ledit élément (14) de fixation et ladite section de contact (13) étant positionnés entre les sections (11, 12) de sertissage sur un conducteur et un isolant ;
 caractérisé en ce que ladite partie surélevée (35) est prévue sur une languette élastique (34) incorporée dans ladite première paroi, et en ce que ledit élément d'engagement (15) est réalisé par déformation vers l'extérieur d'une partie d'un bord latéral (14a) de l'élément de fixation (14) en une configuration incurvée ou polygonale.

FIG.1

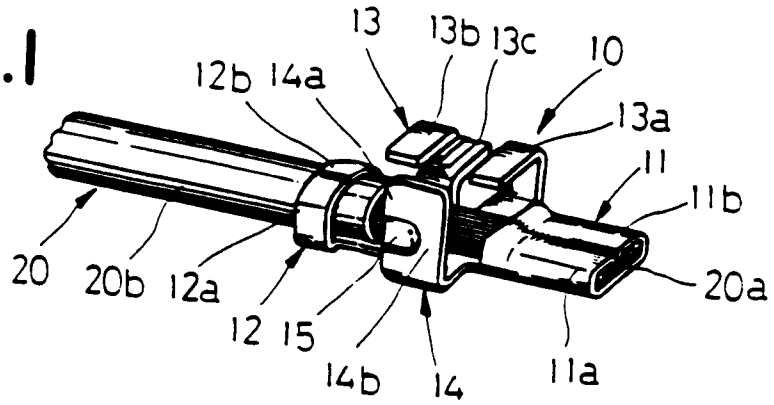

FIG.2

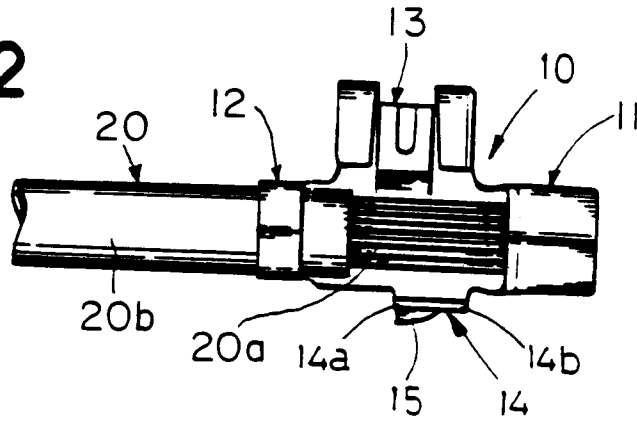

FIG.3

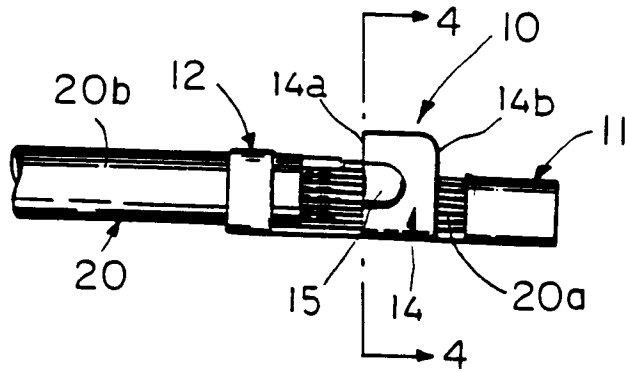

FIG.4

