



Europäisches Patentamt
European Patent Office
Office européen des brevets



Publication number: **0 451 346 B1**

EUROPEAN PATENT SPECIFICATION

- (45) Date of publication of patent specification: **05.07.95** (51) Int. Cl.⁶: **F26B 3/20**, F26B 15/18,
F26B 23/10, B27D 3/04,
(21) Application number: **90123216.5** B30B 5/06, B30B 15/34
(22) Date of filing: **04.12.90**

(54) **Plate treating apparatus using a caterpillar.**

(30) Priority: **29.03.90 JP 82088/90**

(43) Date of publication of application:
16.10.91 Bulletin 91/42

(45) Publication of the grant of the patent:
05.07.95 Bulletin 95/27

(84) Designated Contracting States:
DE FR IT

(56) References cited:
DE-C- 256 293 DE-C- 257 672
DE-C- 803 759 FR-A- 2 412 395
US-A- 2 071 999 US-A- 2 365 804

(73) Proprietor: **KABUSHIKI KAISHA TAIHEI**
SEISAKUSHO
900, Aza Shinmichi,
Ooaza Irukade Shinden
Komaki-shi,
Aichi-ken (JP)

(72) Inventor: **Ariga, Masao**
57, Kitagashira-cho 4-chome,
Minami-ku
Nagoya-shi,
Aichi-ken (JP)

(74) Representative: **Klunker . Schmitt-Nilson .**
Hirsch
Winzererstrasse 106
D-80797 München (DE)

EP 0 451 346 B1

Note: Within nine months from the publication of the mention of the grant of the European patent, any person may give notice to the European Patent Office of opposition to the European patent granted. Notice of opposition shall be filed in a written reasoned statement. It shall not be deemed to have been filed until the opposition fee has been paid (Art. 99(1) European patent convention).

Description

The present invention relates to a plate treating apparatus according to the pre-characterizing part of claim 1, 3 and claim 4, respectively. An apparatus of this type is known from DE-C-256 293 or DE-C-257 672.

Heretofore, to dry a veneer there have been proposed drying methods using various devices: for example, a dryer circulating hot air transversely or longitudinally of the veneer; a multiplaten press having hot plates vertically or laterally arranged, the hot plates being supplied with a heating medium such as steam, hot oil and warm water; a single platen press having hot plates disposed in a single layer; a continuous press having a steel belt, a mesh belt or a metallic sheet wound around each hot plate in an endless shape; a continuous press having endless chains extended around recesses formed in a pair in an outer surface of a hot plate; and a slat conveyor type press using narrow hot plates.

Dryers are widely used for drying veneers. It is well known that in terms of heat efficiency, a single stage press and a multistage press, which bring hot plates into direct contact with a veneer, are superior to an indirect heating dryer circulating hot air over surfaces of veneer. However, such presses are disadvantageous in that mechanisms to convey a veneer to and away from the hot plates are rather complicated, and in that the veneer is liable to be damaged in moving to and away from the hot plates.

In the continuous press, a veneer is placed on an endless steel belt or a pair of chain conveyor and is turned around to move to a position above a hot plate. After heat dried, the veneer is carried away by turning the steel belt or the chain conveyors. In this manner, automatic carrying in and out of the veneer is achieved. When a belt like member, such as a steel belt, is used in the veneer transporting mechanism, the hot plate makes an indirect heat contact with a veneer for heating, resulting in a low heat efficiency. Moreover, such a heating operation can cause the belt like member to be damaged with the lapse of time. In the veneer transporting mechanism using a pair of chain conveyors, an elevating mechanism is needed. The elevating mechanism is actuated to elevate the chain conveyors or a hot plate every time when a veneer is placed on or taken away from the chain conveyors, and when the veneer is brought into contact with the surface of the hot plate. This is because the veneer is turned over while transported by the conveyors.

In the slat conveyor type press, a group of slats are heated, and hence burners, heaters and like devices are arranged at predetermined posi-

tions near the caterpillar for indirect heating of a veneer.

DE-C-256 293 discloses an apparatus according to the pre-characterizing part of claim 1 in which a rotary shaft means provided between the supporting shafts is surrounded by a chamber having circular cross section. The connecting tubes extend in a radial direction from the rotary shaft means and connect said chamber with a plurality of hot plates.

DE-C-257 672 discloses a similar arrangement wherein said chamber surrounding the rotary shaft means is subdivided into a supply chamber and a discharge chamber, wherein both the supply chamber and the discharge chamber is connected to a respective hose disposed substantially parallel with respect to the endless belt of hot plates. Each hot plate is connected with said hose via a short duct. The connection between said endless hoses and the supply chamber and the discharge chamber, respectively, is achieved by means of flexible hoses. The specific structure of the rotary shaft and the supply chamber and the discharge chamber can not be seen from this documents.

The problem underlying the present invention is to provide an apparatus in which the heat transfer medium supplying passage and the heat transfer medium discharge passage can easily be connected to the hot plates.

This is achieved in accordance with the features included in claim 1, 3 or 4.

When the endless belt is actuated, the rotary shaft means is synchronously rotated so that the rotary shaft means makes one revolution for one turn of the endless belt. With such a construction, the heat transfer medium is supplied from the heat transfer medium supply portion of the rotary shaft means to the heat transfer medium passage of each hot plate for heating or cooling the hot plate. After heat exchange is accomplished, the heat transfer medium is returned from the outlet of the heat transfer medium passage to the heat transfer medium discharge portion of the rotary shaft means. Thus, the heat transfer medium is always circulated through each hot plate of the endless belt which is being turned, and hence the heat transfer medium circulating method and the plate treating apparatus according to the present invention are capable of directly heating or cooling hot plates without any outer heat source.

In the drawings;

FIG. 1 is a plan view of one embodiment of the present invention;

FIG. 2 is a side view of the embodiment in FIG. 1;

FIG. 3 is a partly taken away view taken along the line III-III in FIG. 1;

FIG. 4 is a front view of another embodiment in which a pair of caterpillars are one above the other;

FIG. 5 is a partly taken away vertical section of the plate treating apparatus of FIG. 4;

FIG. 6 is a left-hand side view of the plate treating apparatus of FIG. 4;

FIG. 7 is a right-hand side view of the embodiment of FIG. 4;

FIG. 8 is a right-hand view in vertical section of the plate treating apparatus of FIG. 4;

FIG. 9 is a side view illustrating a modified form of the plate treating apparatus of FIG. 4;

FIG. 10 is a plan view, partly taken away, of another embodiment of the present invention with separate heat transfer medium supplying and discharging systems;

FIG. 11 is an enlarged view taken along the line XI-XI in FIG. 10;

FIG. 12 is a plan view, partly taken away, of still another embodiment of the present invention with a single heat transfer medium supplying and discharging system for each caterpillar;

FIG. 13 is an enlarged view taken along the line XIII-XIII of FIG. 12;

FIG. 14 is a side view of another embodiment of the present invention with a caterpillar having a depressing mechanism;

FIG. 15 is a vertical section of the plate treating apparatus of FIG. 14;

FIG. 16 is a vertical section of a modified form of the plate treating apparatus of FIG. 14;

FIG. 17 is a horizontal section of another embodiment of the present invention in which a pair of headers are used in a caterpillar to supply and discharge a heat transfer medium;

FIG. 18 is a plan view of another embodiment of the invention in which carrying in and out of a plate to be treated are facilitated;

FIG. 19 is an enlarged view partly taken away and taken along the line XIX-XIX in FIG. 18;

FIG. 20 is another enlarged view partly taken away and taken along the line XIX-XIX in FIG. 18;

FIG. 21 is a left-hand side view of the plate treating apparatus of FIG. 18;

FIG. 22 is a view taken along the line XXII-XXII in FIG. 18;

FIG. 23 is a side view of a modified form of the plate treating apparatus of FIG. 18 in which two plate treating apparatuses are arranged in series;

FIG. 24 is an enlarged partial side view of a modified form of two combined plate treating apparatuses of FIG. 18;

FIG. 25 is a front view in section of a modified form of the plate treating apparatus of FIG. 4;

FIG. 26 is a plan view of a reciprocating mechanism for reciprocating headers of FIG. 25 to facilitate the actuation of the heat transfer medium circulating system;

FIG. 27 is a side view of the reciprocating mechanism of FIG. 26;

FIG. 28 is a plan view, partly taken away, of another embodiment of the present invention;

FIG. 29 is an enlarged front view of the plate treating apparatus of FIG. 28;

FIG. 30 is an illustration of a modified form of the caterpillar of FIG. 28 in which connecting tubes are coated with flexible cable bears;

FIG. 31 is an illustration of another modified form of the caterpillar of FIG. 28 in which steel belts are placed along connecting tubes;

FIG. 32 is an illustration of another modified form of the caterpillar of FIG. 28 in which connecting tubes are used without any cable bear or steel belt;

FIG. 33 is a fragmentary view in section of the caterpillar of FIG. 32, illustrating how to join connecting tubes and rotary shafts;

FIG. 34 is an enlarged partial view in section of the caterpillar of FIG. 32, illustrating a rotary shaft provided only on one side of the caterpillar for supplying and discharging a heat transfer medium;

FIG. 35 is a fragmentary view showing a plate treating apparatus having a guide device for assuring smooth transfer of plates to be treated from one caterpillar to the succeeding caterpillar;

FIG. 36 shows a modified form using an endless timing belt in place of endless chains;

FIG. 37 is a cross section taken along the line XXXVII-XXXVII in FIG. 36; and

FIG. 38 is a fragmentary view showing a modification of the device shown in FIG. 36.

Embodiments of the present invention will be described below with reference to the drawings.

FIGS. 1 to 3 illustrate a plate treating apparatus according to the present invention. A plate to be heat dried or cooled (hereinafter referred to as plate to be treated) is placed on the plate treating apparatus and is heat treated while being transported.

A pair of vertical frames 1 and 1 are erected on a floor on one side of a caterpillar 9 of the plate treating apparatus, and a pair of parallel beams 2 and 2 are provided to the vertical frames 1 and 1 in the same horizontal plane to laterally extend. A pair of lateral supporting shafts 3 and 3 are supported on bearings (not shown) which are arranged on beams 2 and 2 in a conveying direction of the caterpillar 9.

The caterpillar 9 is constructed as follows. A pair of sprocket wheels 4 and 4 are mounted on

opposite ends of each of the supporting shafts 3 and 3, and a pair of endless chains 5 and 5 extend between sprocket wheels 4 located at respective sides of the caterpillar 9 to form a pair of chain conveyors 6 and 6. A multiplicity of parallel strip-shaped hot plates 8 are closely arranged in an endless manner on the chain conveyors 6 and 6 through attachments 7 secured to outer faces of the chains 5. Each of the hot plates 8 is provided in it with a heat transfer medium passage through which a heating medium or a coolant (both hereinafter referred to as heat transfer medium) passes. The heat transfer medium passage may be formed in a single row or in rows.

A rotary shaft 12 is rotatably supported by bearings on portions of beams 2 and 2, the portions being surrounded by hot plates 8 of the caterpillar 9. The rotary shaft 12 is provided at its one end with a header 12A. The interior of the header 12A is separated into a heat transfer medium supplying portion 10 and a heat transfer medium discharging portion 11. The other end of the rotary shaft 12 near the vertical frames 1 and 1 has a rotary joint 15 fitted around it. The rotary joint 15 is provided with a supply port 13 and a discharging port 14. Connecting tubes 17 are provided to connect between the heat transfer medium supplying portion 10 and an inlet of the heat transfer medium passage of each hot plate 8 and between the heat transfer medium discharging portion 11 and an outlet of the heat transfer medium passage of each hot plate 8. The connecting tubes 17 have such a length that they reach turning portions 16 of the caterpillar 9. The number of the connecting tubes 17 is the same as the number of the hot plates 8 of the caterpillar 9. In the embodiment of FIGS. 1 to 3, the number of hot plates 8 is 32 and hence that of the connecting tubes 17 is 32. In FIGS. 1 and 3, reference numeral 17A designates a connecting pipe binder through which connecting tubes 17 pass for preventing them from being caught in each other.

The caterpillar 9 is, as shown in FIG. 2, rotated by transmitting a driving force of an electric motor 19 to a sprocket wheel 18, mounted around one end of the shaft 3, through a speed reducer 20 and chain 23A. A sprocket wheel 21 which has teeth different in number from the teeth of the sprocket wheel 18 is mounted around the shaft 3. The sprocket wheel 21 is connected to a sprocket wheel 22 on the rotary shaft 12 through a chain 23B in such a manner that one turn of the caterpillar 9 is synchronized with one turn of the rotary shaft 12.

In place of such a mechanical synchronizing mechanism, use may be made of an electrical synchronizing device in which pulse generators are connected to the shaft 3 of the caterpillar 9 and the

rotary shaft 12 for electrical synchronization. Although in this embodiment, the caterpillar 9 is horizontally arranged, it may be installed in an inclined manner or in a vertical manner. When the rotary shaft 12 is placed substantially at a center position within the caterpillar 9 as in this embodiment, distances from the rotary shaft 12 to opposite turning portions 16 of the caterpillar 9 are equal and thus the length of the connecting tubes 17 totally becomes short, but the rotary shaft 12 may be located nearer to one of the turning portions 16.

Supplying of the heat transfer medium to and discharging of it from hot plates 8 are not individually made but made in groups of adjacent hot plates 8. In this embodiment, there are two groups of hot plates 8, each group including 16 hot plates 8. In each group, the inlet of the heat transfer medium passage of a leading hot plate 8 is connected to one end of a U-shaped connecting tube 17. The one end of each connecting tube 17 is extendable to the turning portions 16. The outlet of a hot plate 8 and the inlet of an adjacent hot plate 8 of the same group are communicated through a U-shaped connecting joint 24 as shown in FIG. 1. The outlet of the heat transfer medium passage of a trailing hot plate 8 of the group is communicated to the heat transfer medium discharging portion 11 of the rotary shaft 12 through another connecting tube 17. With such a heat transfer medium circulating unit, only two connecting tubes 17 are used in each of the heat transfer medium supplying portion 10 and heat transfer medium discharging portion 11, and the diameter of the rotary shaft 12 and particularly the diameter of the portion connecting the connecting tube 17 is reduced.

As the electric motor 19 rotates, the caterpillar 9 and the rotary shaft 12 are synchronously controlled so that the rotary shaft 12 makes one revolution for one turn of the caterpillar 9. The rotary shaft 12 has a circular cross section and hence the peripheral speed and the angular speed thereof are constant. The caterpillar 9 forms a track-shaped locus as it turns, and hence the angular speed thereof is not constant although the peripheral speed is constant. Thus, the length of the connecting tubes 17 must be variable due to the difference in locus between the caterpillar 9 and the rotary shaft 12. To meet this requirement, the connecting tubes 17 may use an extendable mechanism, for example, a telescopic cylinder, which can extend from the rotary shaft 12 to the turning portions 16. To prevent twisting of the connecting tubes 17 due to difference in angular speed between the two members, the connecting tubes 17 may be connected through rotary joints between the hot plates 8 and the rotary shaft 12.

Flexible pipes are preferably used for the connecting tubes 17 to vary their length and to prevent twisting. When flexible tubes are used as the connecting tubes 17, their flexible portions gradually extend as hot plates 8 to which they are connected moves from positions nearest to the rotary shaft 12 to turning portions 16 of the caterpillar, and then the flexible tubes gradually bend. Although torsion is applied to each flexible tube as its one end passes through each turning portion 16, the flexibility of the pipe is capable of overcoming the torsion.

Gaps between adjacent hot plates 8 and 8 become slightly wider at each of the turning portion 16 and 16 than at the other positions. Each of the U-shaped connecting joints 24 which circulate a heat transfer medium through a group of hot plates 8 makes the distance between its legs larger at the turning portions 16. At each turning portion 16, a heat transfer medium is always supplied to and discharged from the rotary shaft 12 through the rotary joint 15. When the plate 25 to be treated is a veneer, a heat transfer medium, such as steam or hot oil, passes through the rotary shaft 12 to dry the veneer. A coolant is always transported through the rotary shaft 12 for maintaining the hot plates 8 at a predetermined temperature when the temperature of a dried veneer is to drop to a temperature, at which an adhesive is not cured, for applying the adhesive, or when a resin laminated veneer is to be cooled after hot pressed.

FIGS. 4 to 8 illustrate an embodiment in which a pair of caterpillars 9 of the preceding embodiment are arranged one above the other in an opposing manner. A plate 25 to be treated is conveyed between the caterpillars 9 and 9 in a sandwiched manner for heating or cooling treatment. The opposite surfaces of the plate 25 to be treated are subjected to a thermal treatment and hence efficiency of the thermal treatment is fairly increased.

In a driving system of the upper caterpillar 9, a sprocket wheel 27 which is mounted around the shaft 3 is connected to a sprocket wheel 26 through a chain 28, the sprocket wheel 26 being engaged with the chain 23A which interconnects the speed reducer 20 to the sprocket wheel 18 of the lower caterpillar 9 to transmit rotation. Thus, the upper and lower caterpillars 9 and 9 are turned at the same speed but in opposite directions.

The driving system of the rotary shaft 12 of the upper caterpillar 9 includes a sprocket wheel 30 which is connected to a sprocket wheel 29 through a chain 31. The sprocket wheel 29 engages the chain 23B of the lower caterpillar 9. This driving system transmits to the rotary shaft 12 of the upper caterpillar 9 rotation with the same speed as and in the opposite direction to the rotation of the rotary shaft 12 of the lower caterpillar 9.

To adapt to a change in thickness of the plate 25 to be treated, the beams 2 and 2, which support the upper and lower caterpillar 9 and its accompanying parts in a cantilever fashion, are capable of changing their vertical positions by a suitable devices (not shown) such as screw mechanisms, hydraulic jacks and a like mechanism.

In the plate treating apparatus, a plate 25 to be treated, such as a veneer, is inserted between the upper and lower caterpillars 9 and 9, so that each of opposite surfaces of the plate 25 to be treated makes a direct contact with the hot plates 8 of the corresponding caterpillar 9. As the caterpillars 9 and 9 turn, the plate 25 to be treated passes through flat portions of the caterpillars 9 and 9 to turning portions 16 and 16. During this operation, the plate treating apparatus is capable of drying the plate 25 to be treated.

In place of the upper caterpillar 9 of the plate treating apparatus of FIGS. 4-8, a depressing conveyor including parallel conveyor belts 32 may be, as shown in FIG. 9, arranged above the lower caterpillar 9 in a parallel manner. In the plate treating apparatus of FIG. 9, a plate 25 to be treated, placed on hot plates 8 of the caterpillar 9, is moved by turning the caterpillar 9. During this movement, the plate 25 to be treated is subjected at its lower surface to a direct thermal influence from hot plates 8 which are maintained at a predetermined temperature. Under such a condition, the upper surface of the plate 25 to be treated is slightly depressed by synchronously turning the depressing conveyor 32 in a direction opposite to the turning direction of the caterpillar 9, so that the depressing conveyor 32 depresses the plate 25 to be treated not to separate from the hot plates. This prevents cracks from being produced in a direction of fibers due to contraction.

FIGS. 10 to 13 illustrate two embodiments in which opposite ends of the supporting shafts 3 and 3 of the sprocket wheels are supported. In each embodiment, a pair of vertical frames 1 and 1 are erected with transverse spacing. Two pairs of beams 2 and 2 are provided to each frame 1 in a vertically spaced manner to extend horizontally for supporting corresponding sprocket wheels 4. In FIG. 11, the rotary shaft 12 of the right side of the lower caterpillar 9 is omitted for illustration purpose.

In each of the caterpillars 9 and 9 of the embodiment of FIGS. 10 and 11, a pair of opposed rotary shafts 12 and 12 are used. Each of the rotary shafts 12 is solely for supplying or discharging a heat transfer medium. In the embodiment in FIGS. 12 and 13, two rotary shafts 12 are provided to only one side frame 1 to supply and discharge a heat transfer medium.

In each of the embodiments of FIGS. 10 to 13, connecting tubes 17 are connected to the inner surfaces of the hot plates 8 and are placed within the caterpillars 9 and 9.

In FIGS. 14 and 15, there is illustrated another embodiment, in which hot plates 8 of a pair of caterpillars 9 and 9 are brought into intimate contact to a plate 25 to be treated to improve the efficiency of the thermal processing. A pressing mechanism 33 is provided to a beam 2 of one of the caterpillars 9 and 9 (the upper caterpillar 9 in this embodiment). When the plate 25 to be treated is a plywood board to which a glue is applied, the pressing mechanism 33 enhances the bonding thereof.

The pressing mechanism 33 includes a pair of fluid cylinders 34 and 34 mounted to the beam 2 in a direction perpendicular to the adjacent hot plates 8. A piston rod 35 of each fluid cylinder 34 is fastened at its lower end to one of two pressing bars 36 and 36 (only one of which is shown) through a joint member not shown. The pressing bars 36 and 36 extend in the conveying direction of the plate 25 to be treated.

Two pairs of pendants 37 and 37 are provided to depend from the beam 2 of the upper caterpillar 9. Each pair of pendants 37 and 37 slidably pass through the corresponding pressing bar 36. A locking nut 38 is threaded to the lower end of each pendant 37 to adjust the limit of depressing link portions of the chain 5 to which hot plates 8 are attached. Instead of fluid cylinders 34, conventional crank mechanisms, screw mechanisms or springs may be used.

In the lower caterpillar 9, three pairs of supporting members 39 and 39 are supported on the beam 2 in a threaded manner for adjustment of vertical positions thereof although two pairs of supporting members 39 and 39 are shown in FIG. 16. Two pairs of supporting members 39 and 39 are arranged right below the pressing bars 36 and 36, respectively, and the other one pair is located at a center position of the lower caterpillar 9. Each pair of supporting members 39 and 39 are connected at their upper ends to a supporting bar 40 which is in contact with a link portion of the chain 5 of the lower caterpillar 9. The supporting members 39 and 39 serve to bear reaction forces of the upper caterpillar 9 through the supporting bars 40.

With such a construction, the lower limit of the hot plates which constitute caterpillars 9 and 9 is determined by turning the locking nuts 38 threaded around pendants 37 according to the thickness of the plate 25 to be treated.

In this condition, the piston rods 35 of the fluid cylinders 34 are extended to lower the pressing bars 36. This produces a predetermined pressure between the pressing bars 36 and the supporting

bars 40 of the lower caterpillar 9. When a plate 25 to be treated is inserted between the upper and lower caterpillars 9 and 9, opposite surfaces of the plate 25 to be treated come into direct contact with hot plates 8 of the caterpillars 9 and 9 under pressure, and as the caterpillars 9 and 9 turn, the plate 25 to be treated moves through flat portions thereof to a delivery position at one of the turning portions 16 and 16 of each caterpillar. The plate 25 treated is taken out from the delivery position.

The caterpillars 9 and 9 of FIGS. 14 and 15 are supported on frame 1 in a cantilever fashion. To horizontally maintain the traveling plane of the plate 25 to be treated, a reaction force bearing mechanism may be provided for bearing the upper and lower caterpillars 9 and 9, and is preferably arranged at the sides of the caterpillars 9 and 9 remote from the frame 1. As the reaction force bearing mechanism, a strut, using trains of rollers, or a conveyor including a wide endless belt may be provided in such a manner that the upper traveling surface thereof makes a contact with the lower traveling plane of the lower caterpillar 9. Alternatively, supporting members including discs 51 may be, as illustrated in FIG. 16, arranged to bear the lower traveling plane of lower caterpillar 9, each disc being supported on a pair of rails 50. The discs 51 are located at least at positions just below supporting shafts 3 of the caterpillars 9 and may be also arranged on the side of frame 1 to totally bear vertical reaction forces.

FIG. 17 illustrates another embodiment in which a pair of headers 41 and 41 are provided to supply and discharge a heat transfer medium. The headers 41 and 41 are made of a resilient material such as rubber and are capable of bending at the turning portions 16 and 16 of a caterpillar 9 as the caterpillar 9 turns. More specifically, each of the hot plates 8 is provided at its inner surface with an inlet 42 and outlet 43 of the heat transfer medium passage. The headers 41 and 41 are disposed in parallel with each other along the traveling direction of each caterpillar 9. One of the headers 41 and 41 serves to supply a heat transfer medium and the other to discharge the heat transfer medium. Each of the headers 41 and 41 is longitudinally provided at its outer surface with supply ports or discharge ports which are connected to corresponding inlets 42 or outlets 43 of hot plates 8 through joints (not shown). Both the number of the joints to connect the inlets 42 of hot plates 8 to the supply ports of the one header 41 and the number of the joints to connect outlets 43 to the discharge ports are 32 when the number of the hot plates 8 is 32.

Rotary joints 15 and 15 which supply and discharge the heat transfer medium are arranged in the vicinity of respective vertical frames 1 and 1 opposingly erected. A rotary shaft 12 is rotatably

supported at its proximal end to each of the rotary joints 15 and 15 and is connected at its distal end to the corresponding header 41 through a conventional joint such as a flange.

The flexible headers 41 and 41 is capable of deforming in the shape of the track of the caterpillar 9, and hence they follow the turning of the caterpillar 9 with a gap equal to the length of the joints which interconnect the caterpillar 9 and the headers 41. Also in this embodiment, the headers 41 and 41 are expanded at the turning portions of the caterpillar 9 as gaps between adjacent hot plates 8 become larger.

FIGS. 18 to 22 show an embodiment in which plates 25 to be treated are smoothly carried in and out of plate treating apparatus above described.

A pair of V-shaped or U-shaped grooves 45 and 45 are, as shown in FIG. 20, formed in an outer surface of each hot plate 8 with a longitudinal interval and in parallel with the conveying direction. Two sets of four pulleys 44, 44, 44 and 44 are arranged close to the veneer-carrying-in position and carrying-out position of the lower caterpillar 9, the two sets being disposed in a transversely spaced manner. An endless guiding belt 46, such as a wire, a piano wire and a chain, extends around each set of the pulleys 44, 44, 44 and 44 and fits into a corresponding groove 45.

When a plurality of (two in the embodiment of FIG. 23) plate treating apparatuses are closely installed in series, the caterpillars 9 are arranged so that corresponding grooves 45 of end-to-end facing caterpillars 9 of adjacent plate treating apparatuses are aligned. Several sets of pulleys 44, 44, 44 and 44 are arranged in the vicinity of the plate-carrying-in and -out positions of the combined plate treating apparatuses as shown in FIG. 23, and a guiding belt 46 extends around each set of pulleys 44, 44, 44 and 44 to fit in corresponding grooves 45 of the plate treating apparatuses. This embodiment facilitates the carrying in and out of the plate 25 to be treated and transfer of the plate 25 between two plate treating apparatuses.

Another embodiment in which plate treating apparatuses are arranged in series without guide belts 46 above described is illustrated in FIG. 24. The hot plates 8 of this embodiment are made smaller in width than those of the preceding embodiments. A lower caterpillar 9 of one of adjacent plate treating apparatuses is arranged to project at its one end, for example, a trailing end from one end (trailing end) of the upper caterpillar 9 of the same plate treating apparatus. As shown in FIG. 24, an upper sprocket wheel 4A of the trailing end of the lower caterpillar 9 of the left-hand plate treating apparatus is projected from the trailing end of the upper caterpillar 9 of the same plate treating apparatus. On the other hand, a leading end of an

upper caterpillar 9 of an adjacent or right hand plate treating apparatus is located to project from the leading end of the lower caterpillar 9 of the same plate treating apparatus. Thus in the right-hand plate treating apparatus, a lower sprocket wheel 4B of the leading end of the upper caterpillar 9 is located to project from the leading end of the lower caterpillar 9. The plate treating apparatuses are arranged in such a manner that the projected leading end of the upper caterpillar 9 of the left-hand plate treating apparatus overlaps the projected trailing end of the lower caterpillar of the right-hand plate treating apparatus. In this embodiment, a guide plate member 47 is provided between the projected end of the lower caterpillar 9 of the left-hand plate treating apparatus and the retreated end of the lower caterpillar 9 of the right-hand plate treating apparatus for guiding a plate to be treated.

FIG. 25 illustrates another embodiment in which a heat transfer medium circulating system is provided outside the caterpillars 9 and 9. Sprocket wheels 4 of the caterpillars 9 and 9 are rotatably supported on beams 2 and 2 horizontally projected from one of two vertical frames 1 and 1. The other frame 1 rotatably supports horizontal rotary shafts 12 and 12 of which heat transfer medium supplying portions 10 and heat transfer medium discharging portions 11 are connected to connecting tubes 17. The connecting tubes 17 are connected to hot plates 8 of the caterpillars 9 and 9. Also in this embodiment, the caterpillars 9 and 9 and the rotary shafts 12 and 12 are synchronously turned to swing connecting tubes 17 like jumping ropes to supply and discharge the heat transfer medium.

As shown in FIGS. 26 and 27, the heat transfer medium supplying and discharging header 12A of each rotary shaft 12 is capable of reciprocating between a projection limit X and retreat limit Y by fluid cylinders 48 or like members in such a manner that the heat transfer medium supplying portion 10 and heat transfer medium discharging portion 11 make one reciprocating movement for one turn of the corresponding caterpillar to keep the connecting tubes 17 from being excessively slackened.

FIGS. 28 to 34 illustrate embodiments which enhances the capacity of connecting tubes 17 to follow the shape of the caterpillars 9 and 9. The connecting tubes 17 connect hot plates 8 of the caterpillars 9 and 9 and rotary shafts 12.

In FIGS. 28 and 29, two pairs of sprocket wheels 4 and 4 of each caterpillar 9 are supported on respective vertical frames 1 and 1 erected along opposite sides of the caterpillars 9 and 9. The supporting structure of the caterpillars 9 and 9 and their related structure are the same as those of FIGS. 10 to 13, and hence corresponding parts are designated by like reference numerals and descrip-

tions thereof are omitted. In this embodiment, a flexible member 150 is attached at its opposite ends to each connecting tube 17 in the vicinity of respective ends for protecting the connecting tube 17. The flexible member 150 is deformable according to the curvature of the turning portions 16 and 16. The resiliency and flexibility of the flexible members 150 enables that one revolution of the rotary shafts 12 is synchronized with one turn of respective caterpillars 9. Cable bears 151 which are bendable in the shape of jointed limbs as shown in FIG. 30 or steel belts 152 as in FIG. 31 are suitably used as the flexible members 150. Both connecting tubes 17 and flexible members 150 are resilient and hence bend to follow the curvature of the inner circumference of the caterpillar 9 every time when they reach the turning portions 16. Although each connecting tubes 17 and the corresponding flexible belt 150 cannot be separated from each other, they may be, as shown in FIG. 31, bound with binding members such as a wire 153 at an appropriate interval for positively preventing separation.

The connection of the header 12A of the rotary shaft 12 and hot plates 8 through connecting tubes 17 as shown in FIGS. 30 to 33 is effective for turning the rotary shaft 12 together with the caterpillar 9.

As shown in FIGS. 28 and 29, a sprocket wheel 54 is mounted around one of the supporting shafts 3 and 3 of each pair and is rotated by an electric motor 19 through a speed reducer 55 and a chain (not shown). Each caterpillar 9 is provided with a hollow inside, and hence this embodiment adopts a caterpillar driving system in which supporting shafts 3 and 3 of each pair are independently rotated. The other supporting shaft 3 of the same pair is rotated synchronously with the one supporting shaft 3 by the motor 19 through the speed reducer 55 and a chain transmission including a synchronizing shaft 56. The synchronizing shaft 56 transversely extends below the lower caterpillar 9.

When each of the caterpillars 9 and 9 is turned, the rotary shaft 12 can be synchronously rotated only by the pulling force of the connecting tubes 17 as shown in FIG. 32 since the connecting tubes 17 have rigidity to some extent. Alternatively, a sprocket wheel 57 having teeth different in number from the teeth of the sprocket wheel 54 may be mounted around the same shaft 3, and the sprocket wheel 57 may be connected to a sprocket wheel 58 mounted on the rotary shaft 12 through a chain 59. With this arrangement, the rotary shaft 12 is synchronously controlled in a mechanical manner to make a revolution for a turn of the caterpillar 9. Instead of the mechanical control, an electrical synchronizing control may be adopted in which pulse generators are provided to shafts 3 and rotary

shafts 12 of each caterpillar 9.

In FIGS. 30 and 31, the caterpillars 9 and the rotary shafts 12 thereof are as previously described synchronized by the flexible members 150 and hence the mechanical or electrical synchronization is not necessary.

Also in the embodiments of FIGS. 28 to 32, supplying and discharging of a heat transfer medium are carried out for each group of hot plates 8. Each caterpillar 9 of the embodiments includes two groups of adjacent hot plates 8, each group containing 16 hot plates 8. An inlet 8a of a leading hot plate 8 of each group is connected to a heat transfer medium supplying portion 10 of the rotary shaft 12 through a connecting tube 17 which extends along the inner faces of the hot plates 8 in a plane perpendicular to the rotary shaft 12. As shown in the upper caterpillar 9 of FIG. 29, each of the hot plates 8 is provided in its inner surface with an inlet 8a and an outlet 8b. The inlet 8a of one of the hot plates 8 is connected to the outlet 8b of the adjacent hot plate 8 of the same group through a connecting joint 24. On the other hand, in the lower caterpillar 9 of FIG. 29, each hot plate 8 is provided at its opposite ends with an inlet 8a and an outlet 8b, and the inlet 8a of one end of a hot plate 8 is connected to the outlet 8b of one end of the adjacent hot plate 8 of the same group. The outlet 8b of a hot plate 8, from which the heat transfer medium of the group of the hot plates 8 are discharged, is connected to a discharging part of the rotary shaft 12 through another connecting tube 17, which extends perpendicularly to the rotary shaft 12 and partly along the inner surfaces of some hot plates 8. With such an arrangement, only two connecting tubes 17 are needed for each group of hot plates 8, and hence the diameter of the header 12A of the rotary shaft 12 is reduced. In the plate treating apparatus of FIGS. 28 and 29, a pair of connecting tubes 17 project from each header 12A with an angular interval 180° about an axis of the header 12A.

When only connecting tubes 17 are used or when connecting tubes 17 are combined with flexible members 150, as in FIGS. 28 to 31, the rotary shafts 12 are pulled by those members while rotated, and hence the rotary shafts 12 follows the rotation of the caterpillar 9 with a time lag.

FIG. 34 illustrate a heat transfer medium circulating system for a caterpillar 9 which is supported on a frame in a cantilever fashion. In the system, a pipe 60 is inserted into a hollow rotary shaft 12 and is communicated at one end to a supplying chamber 12B of a header 12A and at the other end to a rotary joint 15. A discharging passage 61 is defined between the rotary shaft 12 and the pipe 60. The discharging passage 61 is communicated at one end to a discharging chamber

12C of the header 12A and the other end thereof is closed with a sealing member 62. An outer shell member 63 surrounds the other end of the rotary shaft 12 to define a discharging chamber 64. The discharging passage 61 communicates to the discharging chamber 64 through a communication hole 65 formed through the rotary shaft 12. The discharging chamber 64 is connected to a drain or a recirculating system through a conduit 66.

In the plate treating apparatus of FIG. 34, connecting tubes 17 are connected to the header 12A perpendicularly to the axis of the rotary shaft 12. This arrangement produces little torsional stress in the connecting tubes 17 and provides excellent synchronization of the rotary shaft 12 with the caterpillar 9. Thus, it is possible to make the circumferential length of the caterpillar 9 fairly long. The rotary shaft 12 is rotated by the pulling force of the connecting tubes 17 plus the physical synchronization control.

FIG. 35 shows a guide device 70 disposed between two adjoining caterpillars for assuring smooth transfer of plates to be treated from one caterpillar to the succeeding caterpillar. The device 70 comprises a guide member 71 pivotally supported by a horizontal pivot 72 which is disposed at a position higher than the supporting shafts of the sprocket wheels 4. The guide member 71 has a concave surface 73 having a curvature equivalent to the curvature of the turning portion 16. At the upper and lower ends of the concave surface 73 there are provided horizontally extending protrusions 74a and 74b. The device 70 further comprises a stationary structure 75 having an upper surface 76 and an upwardly sloping bridging plate 77. Upper and lower compression coil springs 78 and 79 may be interposed between the stationary structure 75 and the guide member 71.

In the horizontal extension of the caterpillar, the hot plates 8 are in mutually adjoining relation without clearances therebetween. However, in the region of the turning portion 16 open gaps are formed between adjoining hot plates 8, as shown, so that without any measures the spring biased upper protrusion 74a would plunge into the gaps. To prevent this, the dimensional relations of the two protrusions and the hot plates on the caterpillar are determined such that during the period in which the upper protrusion 74a is closely facing the surface of any one of the hot plates 8, the lower protrusion 74b is also closely facing the surface of one of the hot plates 8 and that during the period in which the upper protrusion 74a is facing the gaps between adjoining hot plates 8, the lower protrusion 74b is facing the gaps between adjoining hot plates 8 and caused to plunge into the gaps due to the force of the lower spring 79 whereby the upper protrusion 74a is positively prevented from

engaging the gaps.

It will therefore be understood that the upper protrusion 74a slidably engage the surfaces of the hot plates 8 while it is facing the surfaces, thereby to serve for peeling the plates being treated off the surfaces of the hot plates at the moment each plate is entering the region of the turning portion 16, and that the upper protrusion 74a is prevented from plunging into the gaps between adjoining hot plates 8, to positively avoid interference between the protrusion 74a and the hot plates 8. The thus peeled plates are conveyed onto the succeeding caterpillar via the plates 76 and 77.

FIGS. 36 and 37 indicate a modified form in which the caterpillar includes timing belts 80 instead of the endless chains used in the foregoing embodiments. The timing belts 80 have teeth 81 that engage teeth 82 of pulleys 4A used in place of the sprocket wheels 4. To the outer surface of the timing belt 80 is secured a flexible endless plate 83 of a heat resisting material. The plate 83 may be formed integrally with the timing belts 80. Hot plates 8 are secured to the outer surface of the plate 83 by means of bolts 84. Alternatively, the hot plates 8 may be secured to the endless plate 83 through engagement of protrusions 85 and recesses of a dovetail-shaped cross section, as shown in FIG. 38.

The embodiment shown in FIG. 37 has two spaced apart timing belts 80. The space between the two timing belts 80 can be advantageously used for connecting the connecting tubes 17 for the heat transfer medium to the hot plates 8. The use of the timing belts 80 is advantageous in that the pitch of the teeth 81 of the belts 80 need not have a relation to the dimension of the hot plates 8, whereas in the case of the endless chain, the dimension of the hot plates 8 in the longitudinal direction of the chains must be determined on the basis of the pitch of the endless chain.

In the present invention, as the heat transfer medium use may be made of steam, hot oil, warm water or a like medium for heating a plate to be treated. A cooling gas, cold water, or a like medium may be according to the present invention used as the cooling medium.

According to the present invention, various kinds of plate like materials, such as a veneer, chip board, fiber board, resin laminated board, plywood and a like material may be heat dried, hot pressed, or cooled.

Claims

1. A plate treating apparatus comprising:
 - frame means (1) on which a pair of supporting shafts (3) are rotatably mounted in a parallel spaced-apart disposition;

an endless belt (9) passed around wheels (4) mounted on the respective supporting shafts (3) so as to be driven, with a plate (25) to be treated carried on the belt, in an endless configuration having opposite turning portions (16), said endless belt (9) having hot plates (8) disposed in succession along the belt, each hot plate (8) having therein a heat transfer medium passage with an inlet and an outlet;

rotary shaft means (12) provided between said supporting shafts (3) to extend transversely relative to the endless belt (9) having therein a heat transfer medium supplying passage and a heat transfer medium discharging passage; and

connecting tubes (17) for connecting said supplying portion (10) to at least one of the inlets of the heat transfer medium passages and for connecting at least one of the outlets of the heat transfer medium passages to said discharging portion (11), thereby to cause a heat transfer medium to flow from the supplying portion to the discharging portion through said heat transfer medium passages within the hot plates (8), the relation between the rotary shaft means (12) and the endless belt (9) being such that the rotary shaft means (12) makes one revolution for one turn of the endless belt (9),

characterized in that

said rotary shaft means (12) is fixedly mounted at one end thereof on the frame means (1) located at one side of said endless belt (9) and extends in a cantilever fashion through a space within the endless belt to the other side of the endless belt to terminate in a header communicating with said passages of the rotary shaft (12) and having therein heat transfer medium supplying and discharging portions (10,11), wherein the rotary shaft (12) is a coaxial dual pipe defining therein said passages;

said one inlet and one outlet of the hot plate (8) are provided at said other side of the endless belt (9) so that said connecting tubes (17) are provided entirely at said other side.

2. The plate treating apparatus according to claim 1, characterized in that said connecting tubes (17) extend away from said supplying portion (10) and is curved in a U-shape to extend to said discharging portion (11).
3. A plate treating apparatus comprising:
 - frame means (1) on which a pair of supporting shafts (3) are rotatably mounted in a parallel spaced-apart disposition;
 - an endless belt (9) passed around wheels (4) mounted on the respective supporting

shafts (3) so as to be driven, with a plate (25) to be treated carried on the belt, in an endless configuration having opposite turning portions (16), said endless belt (9) having hot plates (8) disposed in succession along the belt, each hot plate (8) having therein a heat transfer medium passage with an inlet and an outlet;

rotary shaft means (12) provided between said supporting shafts (3) to extend transversely relative to the endless belt (9) and having therein a heat transfer medium supplying passage (10) and a heat transfer medium discharging passage (11); and

connecting tubes (17) for connecting said supplying portion (10) to at least one of the inlets of the heat transfer medium passages and for connecting at least one of the outlets of the heat transfer medium passages to said discharging portion (11), thereby to cause a heat transfer medium to flow from the supplying portion to the discharging portion through said heat transfer medium passages within the hot plates (8), the relation between the rotary shaft means (12) and the endless belt (9) being such that the rotary shaft means (12) makes one revolution for one turn of the endless belt (9), characterized in that said rotary shaft means (12) comprises a pair of rotary shafts (12) aligned transversely to said endless belt (9), said rotary shafts (12) having their proximal ends fixedly mounted on said frame means (1) at the opposite sides of the endless belt (9), respectively, and extending in a cantilever fashion into a space within the endless belt (9) to terminate in headers (12A), respectively, which are spaced apart transversely to said endless belt (9), one of said rotary shafts (12) being for supplying the heat transfer medium therethrough and the other rotary shaft (12) being for discharging the heat transfer medium therethrough; and

that said one inlet and one outlet of the hot plate (8) are provided on an inner surface of the endless belt (9), and said connecting tubes (17) is provided within said space of the endless belt (9), the connecting tubes (17) connecting in communication one of said headers (12A) with said one inlet of the hot plate (8) and the other one of said headers (12A) with said one outlet of the hot plate (8).

4. A plate treating apparatus comprising:
 - frame means (1) on which a pair of supporting shafts (3) are rotatably mounted in a parallel spaced-apart disposition;
 - an endless belt (9) passed around wheels (4) mounted on the respective supporting shafts (3) so as to be driven, with a plate (25) to be treated carried

on the belt, in an endless configuration having opposite turning portions (16), said endless belt (9) having hot plates (8) disposed in succession along the belt, each hot plate (8) having therein a heat transfer medium passage with an inlet and an outlet;

rotary shaft means (12) provided between said supporting shafts (3) to extend transversely relative to the endless belt (9) and having a heat transfer medium supplying portion (10) and a heat transfer medium discharging portion (11) which are defined separately; and

connecting tubes (17) for connecting said supplying portion (10) to at least one of the inlets of the heat transfer medium passages and for connecting at least one of the outlets of the heat transfer medium passages to said discharging portion (11), thereby to cause a heat transfer medium to flow from the supplying portion to the discharging portion through said heat transfer medium passages within the hot plates (8), the relation between the rotary shaft means (12) and the endless belt (9) being such that the rotary shaft means (12) makes one revolution for one turn of the endless belt (9), **characterized in that** said rotary shaft means (12) comprises a rotary shaft (12) having a proximal end fixedly mounted on said frame means (1) at one side of the endless belt (9) and extending in a cantilever fashion into a space within the endless belt (9) to terminate in a header (12A); and

that said one inlet and one outlet of the hot plate (8) are provided on an inner surface of the endless belt (9), and said connecting tubes (17) is provided within said space of the endless belt (9), the connecting tubes (17) connecting in communication through said header (12A), said one inlet of the hot plate (8) and said one outlet of the hot plate (8) with said supplying portion (10) and said discharging portion (11), respectively, wherein the rotary shaft (12) is a coaxial dual pipe defining therein said passages.

5. The plate treating apparatus according to claim 3 or 4, **characterized in that** each of said headers (12A) comprises an elongated resilient header (41) extending along the inner surface of the endless belt (9).
6. The plate treating apparatus according to claim 3 or 4, **characterized in that** said connecting tubes (17) are flexible.
7. The plate treating apparatus according to any one of claims 1 to 6, wherein said rotary shaft means (12) is movable toward and away from

the endless belt (9).

8. The plate treating apparatus according to any one of claims 1-7, further comprising flexible members (150,151,152) attached to each of the connecting tubes (17) so as to conform to curvatures of the connecting tubes for protecting the same.
9. The plate treating apparatus according to any one of claims 1 to 7, wherein said hot plates (8) are divided into groups of the hot plates, and each group includes a leading hot plate and a trailing hot plate, wherein in each group the outlet of each hot plate is connected to the inlet of the following adjacent hot plate through a connecting joint (24) thereby to communicate the heat transfer medium passages of adjacent two hot plates in series, and wherein the heat transfer medium supplying portion (10) is connected to the leading hot plate through the connecting means (17), and the trailing hot plate is connected to the heat transfer medium discharging portion (11) through the connecting means (17).
10. The plate treating apparatus according to any one of claims 1 to 9, further comprising another set of a second endless belt (9), second rotary shaft means (12), second connecting means (17; 42, 43) and second synchronously controlling means, which are equivalent to said first mentioned endless belt, rotary shaft means, connecting means and synchronously controlling means, and wherein said second endless belt (9) is disposed above the first endless belt (9) with the lower surface of the second endless belt disposed face-to-face with the upper surface of the first endless belt, so as to define, between said upper and lower surfaces, a planar passage for passing the plate (25) to be treated.
11. The plate treating apparatus according to claim 10, wherein said first endless belt has supporting bars (40) extending along the upper surface thereof, and said second endless belt has pressing bars (33) extending along the lower surface thereof, and wherein pressing means (34, 35) are provided to press the pressing bars (33) downwards against the supporting bars (40).
12. The plate treating apparatus according to claim 10 or 11, wherein said upper surface of the first endless belt (9) has grooves (45) extending in the conveying direction, and endless guide belts (46) are passed through the

grooves (45) and around pulleys (44) in an endless fashion.

13. The plate treating apparatus according any one of claims 1 to 9, further comprising a depressing conveyor (32) disposed above the upper surface of the endless belt (9) so as to define therebetween a clearance passage through which the plate (25) to be treated is passed.
14. The plate treating apparatus according to any one of claims 10 to 12, wherein lower endless belts equivalent to the first endless belt (9) are arranged in series, and upper endless belts equivalent to the second endless belt (9) are arranged in series, and wherein one end of each of the upper endless belts projects horizontally beyond the corresponding end of each of the lower endless belts.
15. The plate treating apparatus according to any one of claims 1 to 14, wherein said endless belt (a) is formed of a timing belt (80).
16. The plate treating apparatus according to claim 15, wherein a heat resistant flexible plate of an endless shape is interposed between the timing belt (80) and the hot plates (8).
17. The plate treating apparatus according to any one of claims 1 to 16, further comprising a guide device (70) disposed adjacent to the downstream end of the endless belt (9) for peeling the plate (25) to be treated off the hot plates (8) at said downstream end to deliver the plate (25) out of the endless belt (9).
18. The plate treating apparatus according to claim 17, wherein the guide device (70) includes a guide member (71) provided to be pivotable around a horizontal pivot (72), said guide member closely embracing a downstream turning portion (16) of the endless belt and having a horizontally extending protrusion (74a) which closely faces the outer surfaces of the hot plates (8) in the region of the downstream end of the endless belt, to peel the plate (25) to be treated off the hot plates (8), said guide member (71) having means (74b) for preventing said protrusion (74a) from plunging into open gaps formed between adjoining hot plates in the region of said turning portion (16).

Patentansprüche

1. Eine Plattenbehandlungsvorrichtung, aufweisend:
eine Rahmeneinrichtung (1), an welcher ein

Paar von tragenden Wellen (3) in einer parallelen, gegenseitig beabstandeten Anordnung in rotierbarer Weise angebracht ist;

ein Endlosband (9), das um Räder (4) herumgeführt ist, die an den entsprechenden tragenden Wellen (3) angeordnet sind, so daß es mit einer zu behandelnden, auf dem Band getragenen Platte (25) in einer Endlos-Konfiguration mit einander gegenüberliegenden Umkehrbereichen (16) angetrieben wird, wobei das Endlosband (9) heiße Platten (8) aufweist, die in Aufeinanderfolge längs des Bandes angeordnet sind, wobei jede heiße Platte (8) hierin eine für ein Wärmeübertragungsmedium dienende Passage mit einem Einlaß und einem Auslaß aufweist;

eine Rotations-Welleneinrichtung (12), die zwischen den tragenden Wellen (3) vorgesehen ist, um sich in Querrichtung relativ dem Endlosband (9) zu erstrecken, und die hierin eine Zuführpassage für das Wärmeübertragungsmedium sowie eine Auslaßpassage für das Wärmeübertragungsmedium aufweist; und Verbindungsleitungen (17) zum Verbinden des Zuführbereiches (10) mit wenigstens einem der Einlässe der Passagen für das Wärmeübertragungsmedium und zum Verbinden wenigstens eines der Auslässe der Passagen für das Wärmeübertragungsmedium mit dem Auslaßbereich (11), um hierdurch ein Wärmeübertragungsmedium zu veranlassen, von dem Zuführbereich zu dem Auslaßbereich durch die Passagen für das Wärmeübertragungsmedium innerhalb der heißen Platten (8) zu strömen, wobei die Beziehung zwischen der Rotations-Welleneinrichtung (12) und dem Endlosband (9) derart ist, daß die Rotations-Welleneinrichtung (12) eine Umdrehung für einen Umlauf des Endlosbandes (9) vollführt,

dadurch gekennzeichnet,

daß die Rotations-Welleneinrichtung (12) an ihrem einen Ende an der Rahmeneinrichtung (1) fest angeordnet ist, welche an einer Seite des Endlosbandes (9) angeordnet ist, und sich in einer auskragenden Weise durch einen Raum innerhalb des Endlosbandes zu der anderen Seite des Endlosbandes erstreckt, um in einem Kopfstück zu enden, das mit den Passagen der Rotations-Welle (12) in Verbindung steht und das hierin einen Zuführbereich (10) und einen Auslaßbereich (11) für das Wärmeübertragungsmedium aufweist, wobei die Rotations-Welle (12) ein koaxiales Doppelrohr ist, welches hierin die Passagen definiert;

daß der eine Einlaß und der eine Auslaß der heißen Platte (8) auf der anderen Seite des Endlosbandes (9) vorgesehen sind, so daß die Verbindungsleitungen (17) gänzlich auf der an-

deren Seite vorgesehen sind.

2. Die Plattenbehandlungsvorrichtung gemäß Anspruch 1,

dadurch gekennzeichnet,

daß sich die Verbindungsleitungen (17) von dem Zuführbereich (10) weg erstrecken und in einer U-Form gekrümmt sind, um sich zu dem Auslaßbereich (11) zu erstrecken.

3. Eine Plattenbehandlungsvorrichtung, aufweisend:

eine Rahmeneinrichtung (1), an welcher ein Paar von tragenden Wellen (3) in einer parallelen, gegenseitig beabstandeten Anordnung rotierbar angebracht ist;

ein Endlosband (9), das um Räder (4) herumgeführt ist, die an den entsprechenden tragenden Wellen (3) angeordnet sind, so daß es mit einer zu behandelnden, auf dem Band getragenen Platte (25) in einer Endlos-Konfiguration mit einander gegenüberliegenden Umkehrbereichen (16) angetrieben wird, wobei das Endlosband (9) heiße Platten (8) aufweist, die in Aufeinanderfolge längs des Bandes angeordnet sind, wobei jede heiße Platte (8) hierin eine für ein Wärmeübertragungsmedium dienende Passage mit einem Einlaß und einem Auslaß aufweist;

eine Rotations-Welleneinrichtung (12), die zwischen den tragenden Wellen (3) vorgesehen ist, um sich in Querrichtung relativ zu dem Endlosband (9) zu erstrecken, und die hierin eine Zuführpassage (10) für das Wärmeübertragungsmedium und eine Auslaßpassage (11) für das Wärmeübertragungsmedium aufweist; und

Verbindungsleitungen (17) zum Verbinden des Zuführbereiches (10) mit wenigstens einem der Einlässe der Passagen für das Wärmeübertragungsmedium und zum Verbinden wenigstens eines der Auslässe der Passagen für das Wärmeübertragungsmedium mit dem Auslaßbereich (11), um hierdurch ein Wärmeübertragungsmedium zu veranlassen, von dem Zuführbereich zu dem Auslaßbereich durch die Passagen für das Wärmeübertragungsmedium innerhalb der heißen Platten (8) zu strömen, wobei die Beziehung zwischen der Rotations-Welleneinrichtung (12) und dem Endlosband (9) derart ist, daß die Rotations-Welleneinrichtung (12) eine Umdrehung für einen Umlauf des Endlosbandes (9) vollführt,

dadurch gekennzeichnet,

daß die Rotations-Welleneinrichtung (12) ein Paar von Rotations-Wellen (12) aufweist, welche quer zu dem Endlosband (9) ausgerichtet sind, wobei die proximalen Enden der Rota-

tions-Wellen (12) an der Rahmeneinrichtung (1) auf den entgegengesetzten Seiten des Endlosbandes (9) fest angeordnet sind und die Rotations-Wellen sich in einer auskragenden Weise in einen Raum innerhalb des Endlosbandes (9) hineinerstrecken, um in Kopfstücken (12A) zu enden, welche in Querrichtung in bezug auf das Endlosband (9) gegenseitig beabstandet sind, wobei eine der Rotations-Wellen (12) zum Zuführen des Wärmeübertragungsmediums durch sie hindurch und die andere Rotations-Welle (12) zum Auslassen des Wärmeübertragungsmediums durch sie hindurch vorgesehen sind; und

daß der eine Einlaß und der eine Auslaß der heißen Platte (8) auf einer inneren Oberfläche des Endlosbandes (9) vorgesehen sind und die Verbindungsleitungen (17) innerhalb des Raumes des Endlosbandes (9) vorgesehen sind, wobei die Verbindungsleitungen (17) in Kommunikation eines der Kopfstücke (12A) mit dem einen Einlaß der heißen Platte (8) und das andere der Kopfstücke (12A) mit dem einen Auslaß der heißen Platte (8) verbinden.

4. Eine Plattenbehandlungsvorrichtung, aufweisend:

eine Rahmeneinrichtung (1), an welcher ein Paar von tragenden Wellen (3) in einer parallelen, gegenseitig beabstandeten Anordnung rotierbar angebracht ist;

ein Endlosband (9), das um Räder (4) herumgeführt ist, die an den entsprechenden tragenden Wellen (3) angeordnet sind, so daß es mit einer zu behandelnden, auf dem Band getragenen Platte (25) in einer Endlos-Konfiguration mit einander gegenüberliegenden Umkehrbereichen (16) angetrieben wird, wobei das Endlosband (9) heiße Platten (8) aufweist, die in Aufeinanderfolge längs des Bandes angeordnet sind, wobei jede heiße Platte (8) hierin eine für ein Wärmeübertragungsmedium dienende Passage mit einem Einlaß und einem Auslaß aufweist;

eine Rotations-Welleneinrichtung (12), die zwischen den tragenden Wellen (3) vorgesehen ist, um sich in Querrichtung relativ zu dem Endlosband (9) zu erstrecken, und die einen Zuführbereich (10) für das Wärmeübertragungsmedium sowie einen Auslaßbereich (11) für das Wärmeübertragungsmedium aufweist, welche voneinander getrennt definiert sind; und

Verbindungsleitungen (17) zum Verbinden des Zuführbereiches (10) mit wenigstens einem der Einlässe der Passagen für das Wärmeübertragungsmedium und zum Verbinden wenigstens eines der Auslässe der Passagen für das Wär-

meübertragungsmedium mit dem Auslaßbereich (11), um hierdurch ein Wärmeübertragungsmedium zu veranlassen, von dem Zuführbereich zu dem Auslaßbereich durch die Passagen für das Wärmeübertragungsmedium innerhalb der heißen Platten (8) zu strömen, wobei die Beziehung zwischen der Rotations-Welleneinrichtung (12) und dem Endlosband (9) derart ist, daß die Rotations-Welleneinrichtung (12) eine Umdrehung für einen Umlauf des Endlosbandes (9) vollführt,

dadurch gekennzeichnet,

daß die Rotations-Welleneinrichtung (12) eine Rotations-Welle (12) aufweist, die ein proximales Ende hat, das an der Rahmeneinrichtung (1) auf einer Seite des Endlosbandes (9) fest angeordnet ist, und die sich in einer auskragenden Weise in einen Raum innerhalb des Endlosbandes (9) hineinerstreckt, um in einem Kopfstück (12A) zu enden; und

daß der eine Einlaß und der eine Auslaß der heißen Platte (8) auf einer inneren Oberfläche des Endlosbandes (9) vorgesehen sind und die Verbindungsleitungen (17) innerhalb des Raumes des Endlosbandes (9) vorgesehen sind, wobei die Verbindungsleitungen (17) in Kommunikation durch das Kopfstück (12A) den einen Einlaß der heißen Platte (8) mit dem Zuführbereich (10) und den einen Auslaß der heißen Platte (8) mit dem Auslaßbereich (11) verbinden, wobei die Rotations-Welle (12) ein koaxiales Doppelrohr ist, welches hierin die Passagen definiert.

5. Die Plattenbehandlungsvorrichtung gemäß Anspruch 3 oder 4,

dadurch gekennzeichnet,

daß jedes der Kopfstücke (12A) ein langgestrecktes elastisches Kopfstück (41) aufweist, das sich entlang der inneren Oberfläche des Endlosbandes (9) erstreckt.

6. Die Plattenbehandlungsvorrichtung gemäß Anspruch 3 oder 4,

dadurch gekennzeichnet,

daß die Verbindungsleitungen (17) flexible Leitungen sind.

7. Die Plattenbehandlungsvorrichtung gemäß einem der Ansprüche 1 bis 6, bei welcher die Rotations-Welleneinrichtung (12) zu dem Endlosband (9) hin in und von diesem weg bewegbar ist.

8. Die Plattenbehandlungsvorrichtung gemäß einem der Ansprüche 1 bis 7, ferner flexible Elemente (150,151,152) aufweisend, welche an jedem der Verbindungsleitungen (17) derart

angebracht sind, daß sie sich den Krümmungen der Verbindungsleitungen anpassen, um diese zu schützen.

9. Die Plattenbehandlungsvorrichtung gemäß einem der Ansprüche 1 bis 7, bei welcher die heißen Platten (8) in Gruppen von heißen Platten unterteilt sind und jede Gruppe eine vordere heiße Platte und eine hintere heiße Platte aufweist, in jeder Gruppe der Auslaß jeder heißen Platte mit dem Einlaß der folgenden, benachbarten heißen Platte durch eine Verbindungsverbindung (24) verbunden ist, um hierdurch ein Kommunizieren der Passagen für das Wärmeübertragungsmedium von zwei benachbarten heißen Platten hintereinander zu erreichen, und der Zuführbereich (10) für das Wärmeübertragungsmedium mit der vorderen heißen Platte durch die Verbindungsmittel (17) verbunden ist und die hintere heiße Platte mit dem Auslaßbereich (11) für das Wärmeübertragungsmedium durch die Verbindungsmittel (17) verbunden ist.

10. Die Plattenbehandlungsvorrichtung gemäß einem der Ansprüche 1 bis 9, ferner aufweisend: Einen weiteren Satz aus einem zweiten Endlosband (9), einer zweiten Rotations-Welleneinrichtung (12), zweiten Verbindungsmitteln (17;42,43) und zweiten synchron steuernden Mitteln, welche Elemente zu den zuerst erwähnten Elementen, nämlich dem Endlosband, der Rotations-Welleneinrichtung, den Verbindungsmitteln und den synchron steuernden Mitteln äquivalent sind, wobei das zweite Endlosband (9) oberhalb des ersten Endlosbandes (9) angeordnet ist, wobei die Unterseite des zweiten Endlosbandes gegenüber der Oberseite des ersten Endlosbandes angeordnet ist, so daß zwischen der Oberseite und der Unterseite ein ebener Durchgang zum Hindurchgehen der zu behandelnden Platte (25) begrenzt wird.

11. Die Plattenbehandlungsvorrichtung gemäß Anspruch 10, bei welcher das erste Endlosband Tragstangen (40) aufweist, welche sich entlang seiner Oberseite erstrecken, und das zweite Endlosband Andrückstangen (33) aufweist, die sich entlang seiner Unterseite erstrecken, und bei welcher eine Andrückeinrichtung (34,35) vorgesehen ist, um die Andrückstangen (33) nach unten zu den Tragstangen (40) zu drücken.

12. Die Plattenbehandlungsvorrichtung gemäß Anspruch 10 oder 11, bei welcher die Oberseite des ersten Endlosbandes (9) Nuten (45) aufweist, die sich in der Förderrichtung erstrek-

ken, und endlose Führungsbänder (46) durch die Nuten (45) und um Rollen (44) herum in einer endlosen Weise gehen.

13. Die Plattenbehandlungsvorrichtung gemäß einem der Ansprüche 1 bis 9, ferner einen niederdrückenden Förderer (32) aufweisend, der oberhalb der Oberseite des Endlosbandes (9) so angeordnet ist, daß eine freie Passage zwischen Förderer und Endlosband begrenzt wird, durch welche die zu behandelnde Platte (25) geschickt wird. 5 10
14. Die Plattenbehandlungsvorrichtung gemäß einem der Ansprüche 10 bis 12, bei welcher untere Endlosbänder, welche zu dem ersten Endlosband (9) gleichwertig sind, in Reihe angeordnet sind und obere Endlosbänder, welche zu dem zweiten Endlosband (9) gleichwertig sind, in Reihe angeordnet sind und in welcher das eine Ende eines jeden der oberen Endlosbänder horizontal über das entsprechende Ende eines jeden der unteren Endlosbänder hinausgeht. 15 20 25
15. Die Plattenbehandlungsvorrichtung gemäß einem der Ansprüche 1 bis 14, bei welcher das Endlosband (9) durch ein Band (80) mit formschlüssigem Eingriff gebildet ist. 30
16. Die Plattenbehandlungsvorrichtung gemäß Anspruch 15, bei welcher eine wärmebeständige, flexible Platte von einer endlosen Gestalt zwischen dem Band (80) mit formschlüssigem Eingriff und den heißen Platten (8) angeordnet ist. 35
17. Die Plattenbehandlungsvorrichtung gemäß einem der Ansprüche 1 bis 16, ferner eine Führungseinrichtung (70) aufweisend, die benachbart zu dem stromabwärtsseitigen Ende des Endlosbandes (9) angeordnet ist, um die zu behandelnde Platte (25) von den heißen Platten (8) an diesem stromabwärtsseitigen Ende abzulösen, so daß die Platte (25) von dem Endlosband (9) freigegeben wird. 40 45
18. Die Plattenbehandlungsvorrichtung gemäß Anspruch 17, bei welcher die Führungseinrichtung (70) ein Führungselement (71) umfaßt, welches um eine horizontale Schwenkachse (72) schwenkbare ist, wobei das genannte Führungselement einen stromabwärtsseitigen Umkehrbereich (16) des Endlosbandes eng umschließt und einen sich horizontal erstreckenden Vorsprung (74a) aufweist, welcher den äußeren Oberflächen der heißen Platten (8) in der Zone des stromabwärtsseitigen Endes des 50 55

Endlosbandes dicht zugewandt, um die zu behandelnde Platte (25) von den heißen Platten (8) abzulösen, wobei das Führungselement (71) Mittel (74b) aufweist, um den Vorsprung (74a) an einem Eintauchen in offene Spalte zu hindern, die zwischen benachbarten heißen Platten in der Zone des Umkehrbereiches (16) gebildet sind.

Revendications

1. Appareil pour traiter des plaques comprenant :
 un moyen (1) de cadre sur lequel sont montés rotatifs deux arbres support parallèles (3) espacés l'un de l'autre ;
 une courroie sans fin (9) passant sur des poulies (4) montées sur les arbres support respectifs (3), de façon à être entraînée en même temps qu'une plaque (25) à traiter placée sur la courroie, suivant une trajectoire sans fin comprenant des parties arrondies opposées (16), ladite courroie sans fin (9) supportant des plaques chaudes (8) disposées l'une après l'autre le long de la courroie, chaque plaque chaude (8) comportant, à l'intérieur, un passage pour un milieu de transfert thermique avec une entrée et une sortie ;
 un moyen (12) d'arbre rotatif monté entre lesdits arbres support (3), de façon à être orienté transversalement par rapport à la courroie sans fin (9), comportant à l'intérieur un passage d'alimentation en milieu de transfert thermique et un passage de distribution d'un milieu de transfert thermique ; et
 des tubes (17) de raccordement pour relier ladite partie d'alimentation (10) à au moins une des entrées de passage pour le milieu de transfert thermique et pour relier au moins une des sorties desdits passages pour le milieu de transfert thermique à ladite partie (11) de distribution, de façon à créer une circulation du milieu de transfert thermique, depuis la partie d'alimentation jusqu'à la partie de distribution, en suivant lesdits passages pour le milieu de transfert thermique ménagés dans les plaques chaudes (8), la relation entre le moyen d'arbre rotatif (12) et la courroie sans fin (9) étant telle que le moyen d'arbre rotatif (12) fait un tour par tour de la courroie sans fin (9), caractérisé en ce que ledit moyen d'arbre rotatif (12) est rigidement monté à une de ses extrémités sur le moyen de cadre (1) disposé d'un côté de ladite courroie sans fin (9) et s'étend en porte-à-faux à travers un espace situé à l'intérieur de la courroie sans fin jusqu'à l'autre côté de la courroie sans fin pour se terminer dans une tubulure communiquant avec lesdits passages de l'arbre rotatif (12) et comprenant à l'inté-

rieur les parties (10, 11) d'alimentation et de distribution du milieu de transfert thermique, dans lequel l'arbre rotatif (12) est une double conduite coaxiale définissant lesdits passages à l'intérieur ;

ladite entrée et ladite sortie de la plaque chaude (8) sont prévues sur ledit autre côté de la courroie sans fin (9) de manière que lesdites conduites (17) de raccordement soient totalement montées dudit autre côté.

2. Appareil pour traiter des plaques selon la revendication 1, caractérisé en ce que lesdites conduites de raccordement (17) se prolongent en s'éloignant de ladite partie d'alimentation (10) et sont coudées en forme de U pour s'étendre jusqu'à ladite partie de distribution (11).

3. Appareil pour traiter des plaques comprenant : un moyen de cadre (1) sur lequel sont montés rotatifs deux arbres support parallèles (3) espacés l'un de l'autre ;

une courroie sans fin (9) passant autour de poulies (4) montées sur les arbres support respectifs (3) de façon à être entraînée, en même temps qu'une plaque (25) à traiter, placée sur la courroie, selon une trajectoire sans fin comprenant des parties tournantes opposées (16), ladite courroie sans fin (9) portant des plaques chaudes (8) disposées l'une après l'autre le long de la courroie, chaque plaque chaude (8) comportant à l'intérieur un passage pour un milieu de transfert thermique ayant une entrée et une sortie ;

un moyen d'arbre rotatif (12) monté entre lesdits arbres support (3) de façon à être orienté transversalement par rapport à la courroie sans fin (9) et comportant à l'intérieur un passage (10) d'alimentation en milieu de transfert thermique et un passage (11) de distribution du milieu de transfert thermique ; et

des tubes (17) de raccordement pour relier ladite partie d'alimentation (10) à au moins une des entrées des passages pour le milieu de transfert thermique, et pour relier au moins une des sorties des passages pour le milieu de transfert thermique à ladite partie de distribution (11), de façon à créer une circulation du milieu de transfert thermique depuis la partie d'alimentation jusqu'à la partie de distribution en passant par lesdits passages pour le milieu de transfert thermique, ménagés dans les plaques chaudes (8), la relation entre le moyen d'arbre rotatif (12) et la courroie sans fin (9) étant telle que le moyen (12) d'arbre rotatif fait un tour par tour de la courroie sans fin (9), caractérisé en ce que ledit moyen d'arbre rota-

tif (12) est constitué par deux arbres rotatifs (12) alignés perpendiculairement à ladite courroie sans fin (9), lesdits arbres rotatifs (12) ayant leurs extrémités proximales rigidement fixées sur ledit moyen (1) de cadre sur les côtés opposés de la courroie sans fin (9), respectivement, et s'étendant en porte-à-faux dans un espace situé à l'intérieur de la courroie sans fin (9) pour se terminer, respectivement, dans des tubulures (12A) qui sont transversalement espacées de ladite courroie sans fin (9), l'un desdits arbres rotatifs (12) étant destiné à appliquer ledit milieu de transfert en circulation, et l'autre arbre rotatif (12) étant destiné à distribuer le milieu de transfert qui le traverse ; et

en ce que ladite entrée et ladite sortie de la plaque chaude (8) sont prévues sur une surface intérieure de la courroie sans fin (9), et en ce que lesdits tubes (17) de raccordement sont montés dans ledit espace de la courroie sans fin (9), lesdits tubes (17) de raccordement reliant en communication l'une desdites tubulures (12A) avec ladite entrée de la plaque chaude (8), et l'autre desdites tubulures (12A) avec ladite sortie de la plaque chaude (8).

4. Appareil pour traiter des plaques comprenant : un moyen de cadre (1) sur lequel sont montés rotatifs deux arbres support parallèles (3) espacés l'un de l'autre ;

une courroie sans fin (9) passant sur des poulies (4) montées sur les arbres support respectifs (3), de façon à être entraînée, en même temps qu'une plaque (25) à traiter, placée sur la courroie, selon une trajectoire sans fin comprenant des parties tournantes opposées (16), ladite courroie sans fin (9) supportant des plaques chaudes (8) disposées l'une après l'autre le long de la courroie, chaque plaque chaude (8) comportant à l'intérieur, un passage pour un milieu de transfert thermique avec une entrée et une sortie ;

un moyen (12) d'arbre rotatif monté entre lesdits arbres support (3), de façon à être orienté perpendiculairement à la courroie sans fin (9), et comportant une partie (10) d'alimentation en milieu de transfert thermique et une partie (11) de distribution du milieu de transfert thermique, qui sont définies séparément ; et

des tubes (17) de raccordement pour relier ladite partie (10) d'alimentation à au moins une des entrées des passages pour le milieu de transfert thermique et pour relier au moins une des sorties desdits passages pour le milieu de transfert thermique à ladite partie de distribution (11), de façon à établir une circulation du milieu de transfert thermique depuis la partie

d'alimentation jusqu'à la partie de distribution, en suivant lesdits passages pour le milieu de transfert thermique, ménagés dans les plaques chaudes (8), la relation entre le moyen d'arbre rotatif (12) et la courroie sans fin (9) étant telle que le moyen (12) d'arbre rotatif fait un tour par tour de la courroie sans fin (9), caractérisé en ce que ledit moyen (12) d'arbre rotatif comprend un arbre rotatif (12) ayant une extrémité proximale rigidement fixée sur ledit moyen de cadre (1), d'un côté de ladite courroie sans fin (9), et s'étendant en porte-à-faux à travers un espace situé à l'intérieur de la courroie sans fin (9) pour se terminer dans une tubulure (12A) ; et

en ce que ladite entrée et ladite sortie de la plaque chaude (8) sont prévues sur une surface intérieure de la courroie sans fin (9) et en ce que lesdits tubes (17) de raccordement sont montés dans ledit espace de la courroie sans fin (9), les tubes (17) de raccordement reliant en communication, par l'intermédiaire de ladite tubulure (12A), ladite entrée de la plaque chaude (8) et ladite sortie de la plaque chaude (8), avec ladite partie d'alimentation (10) et ladite partie de distribution (11), respectivement, dans lequel l'arbre rotatif (12) est un double tuyau coaxial définissant lesdits passages à l'intérieur.

5. Appareil pour traiter des plaques selon la revendication 3 ou 4, caractérisé en ce que chacune desdites tubulures (12A) est constituée par une tubulure élastique allongée (41) s'étendant le long de la surface intérieure de la courroie sans fin (9).
6. Appareil pour traiter des plaques selon la revendication 3 ou 4, caractérisé en ce que lesdits tubes (17) de raccordement sont flexibles.
7. Appareil pour traiter des plaques selon l'une quelconque des revendications 1 à 6, dans lequel ledit moyen (12) d'arbre rotatif est mobile pour s'approcher et s'éloigner de ladite courroie sans fin (9).
8. Appareil pour traiter des plaques selon l'une quelconque des revendications 1 à 7, comprenant en outre des éléments souples (150, 151, 152), fixés à chacun des tubes (17) de raccordement, de manière à suivre les courbures des tubes de raccordement pour les protéger.
9. Appareil pour traiter des plaques selon l'une quelconque des revendications 1 à 7, dans lequel lesdites plaques chaudes (8) sont parta-

gées en groupes de plaques chaudes, et chaque groupe comprend une première plaque chaude et une dernière plaque chaude, dans lequel, à l'intérieur de chaque groupe, la sortie de chaque plaque chaude est reliée à l'entrée de la plaque chaude adjacente suivante par un joint de raccordement (24), de façon à faire communiquer les passages pour le milieu de transfert thermique de deux plaques chaudes adjacentes montées en série, et dans lequel la partie (10) d'alimentation en milieu de transfert thermique est reliée à la première plaque chaude par le moyen (17) de raccordement, et la dernière plaque chaude est reliée à la partie (11) de distribution du milieu de transfert thermique par les moyens (17) de raccordement.

10. Appareil pour traiter des plaques selon l'une quelconque des revendications 1 à 9, comprenant en outre un autre ensemble formé d'une seconde courroie sans fin (9), d'un second moyen d'arbre rotatif (12), d'un second moyen de raccordement (17 ; 42, 43) et d'un second moyen de commande synchrone, lesquels sont équivalents à la première courroie sans fin, au premier moyen d'arbre rotatif, et au premier moyen de raccordement, et au moyen de commande synchrone mentionnés, et dans lequel ladite seconde courroie sans fin (9) est placée au-dessus de la première courroie sans fin (9), la surface inférieure de la seconde courroie sans fin étant placée face à face avec la surface supérieure de la première courroie sans fin, de manière à délimiter, entre lesdites surfaces supérieure et inférieure un passage plan pour la circulation de la plaque (25) à traiter.
11. Appareil pour traiter des plaques selon la revendication 10, dans lequel ladite première courroie sans fin comprend des barres support (40) s'étendant le long de sa surface supérieure, et ladite seconde courroie sans fin comprend des barres (33) de compression s'étendant le long de sa surface inférieure, et dans lequel des moyens (34, 35) de compression sont prévus pour comprimer les barres (33) de compression vers le bas, contre les barres support (40).
12. Appareil pour traiter des plaques selon la revendication 10 ou 11, dans lequel ladite surface supérieure de la première courroie sans fin (9) comprend des rainures (45) orientées dans la direction de déplacement, et des courroies (46) de guidage sans fin sont introduites dans les rainures (45) et passent autour de poulies (44) suivant une trajectoire sans fin.

13. Appareil pour traiter des plaques selon l'une quelconque des revendications 1 à 9, comprenant en outre un convoyeur de dépression (32) placé au-dessus de la surface supérieure de la courroie sans fin (9) de manière à définir entre eux un passage libre par lequel circule la plaque (25) à traiter. 5
14. Appareil pour traiter des plaques selon l'une quelconque des revendications 10 à 12, dans lequel des courroies inférieures sans fin, équivalentes à la première courroie sans fin (9), sont montées en série, et des courroies supérieures sans fin, équivalentes à la seconde courroie sans fin (9), sont montées en série, et dans lequel une extrémité de chacune des courroies supérieures sans fin fait saillie horizontalement au-delà de l'extrémité correspondante de chacune des courroies sans fin inférieures. 10
15
15. Appareil pour traiter des plaques selon l'une quelconque des revendications 1 à 14, dans lequel ladite courroie sans fin (9) est une courroie de calage (80). 25
16. Appareil pour traiter des plaques selon la revendication 15, dans lequel une plaque flexible, résistant à la chaleur, en forme de courroie sans fin, est intercalée entre la courroie de calage (80) et les plaques chaudes (8). 30
17. Appareil pour traiter des plaques selon l'une quelconque des revendications 1 à 16, comprenant encore un dispositif (70) de guidage monté adjacent à l'extrémité aval de la courroie sans fin (9), pour dégager la plaque (25) à traiter des plaques chaudes (8), sur ladite extrémité aval, de façon à sortir la plaque (25) de la courroie sans fin (9). 35
40
18. Appareil pour traiter des plaques selon la revendication 17, dans lequel le dispositif de guidage (70) comprend un élément (71) de guidage monté pivotant autour d'un pivot horizontal (72), ledit élément de guidage entourant étroitement une partie tournante aval (16) de la courroie sans fin, et ayant un prolongement (74a) orienté horizontalement, qui se trouve proche de et face aux surfaces extérieures des plaques chaudes (8), dans la région de l'extrémité aval de la courroie sans fin, pour dégager la plaque (25) à traiter des plaques chaudes (8), ledit élément (71) de guidage comprenant des moyens (74b) pour empêcher ledit prolongement (74a) de pénétrer à l'intérieur des espaces ouverts formés entre des plaques chaudes adjacentes dans la région de ladite partie 45
50
55

tournante (16).

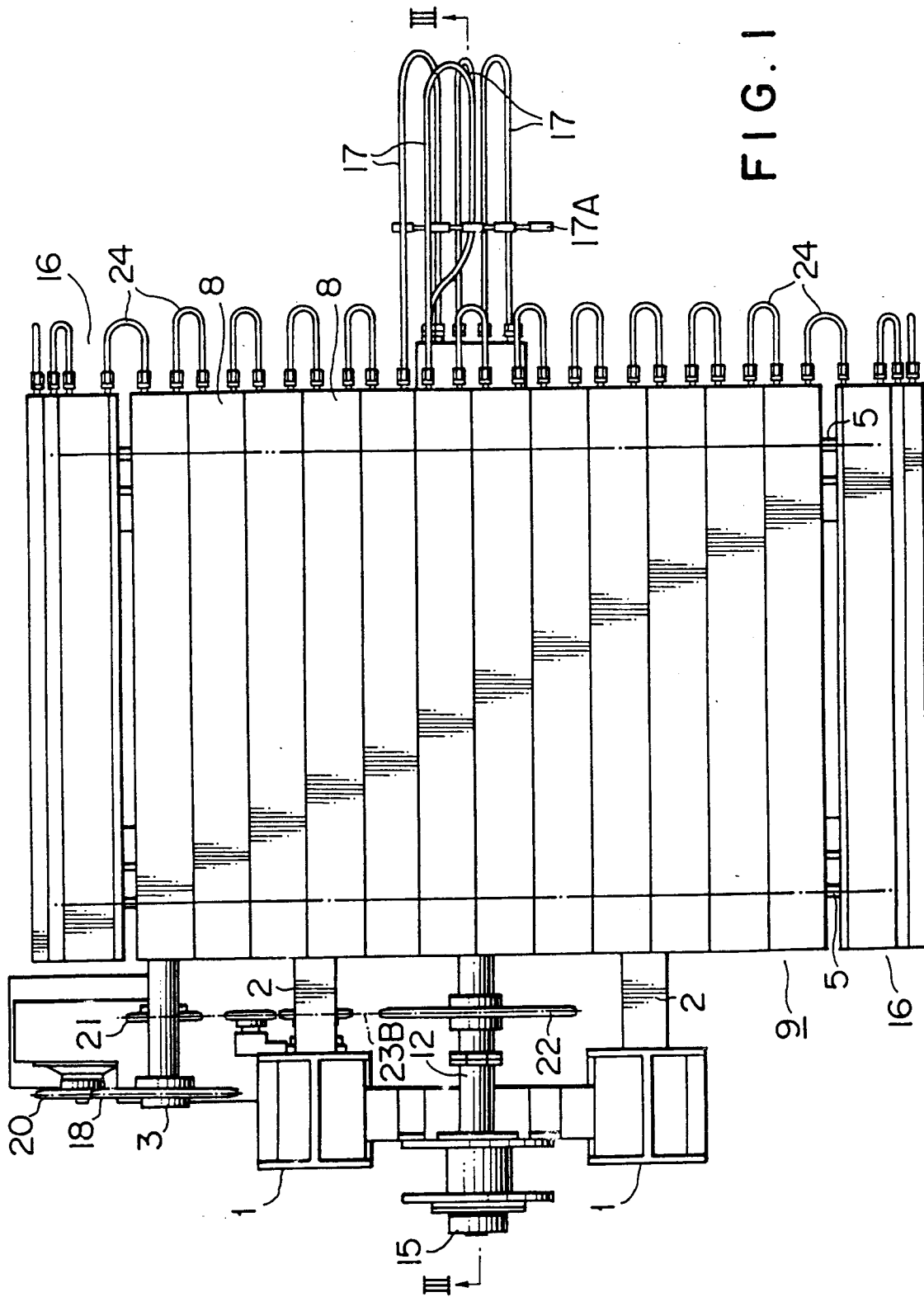

FIG. 1

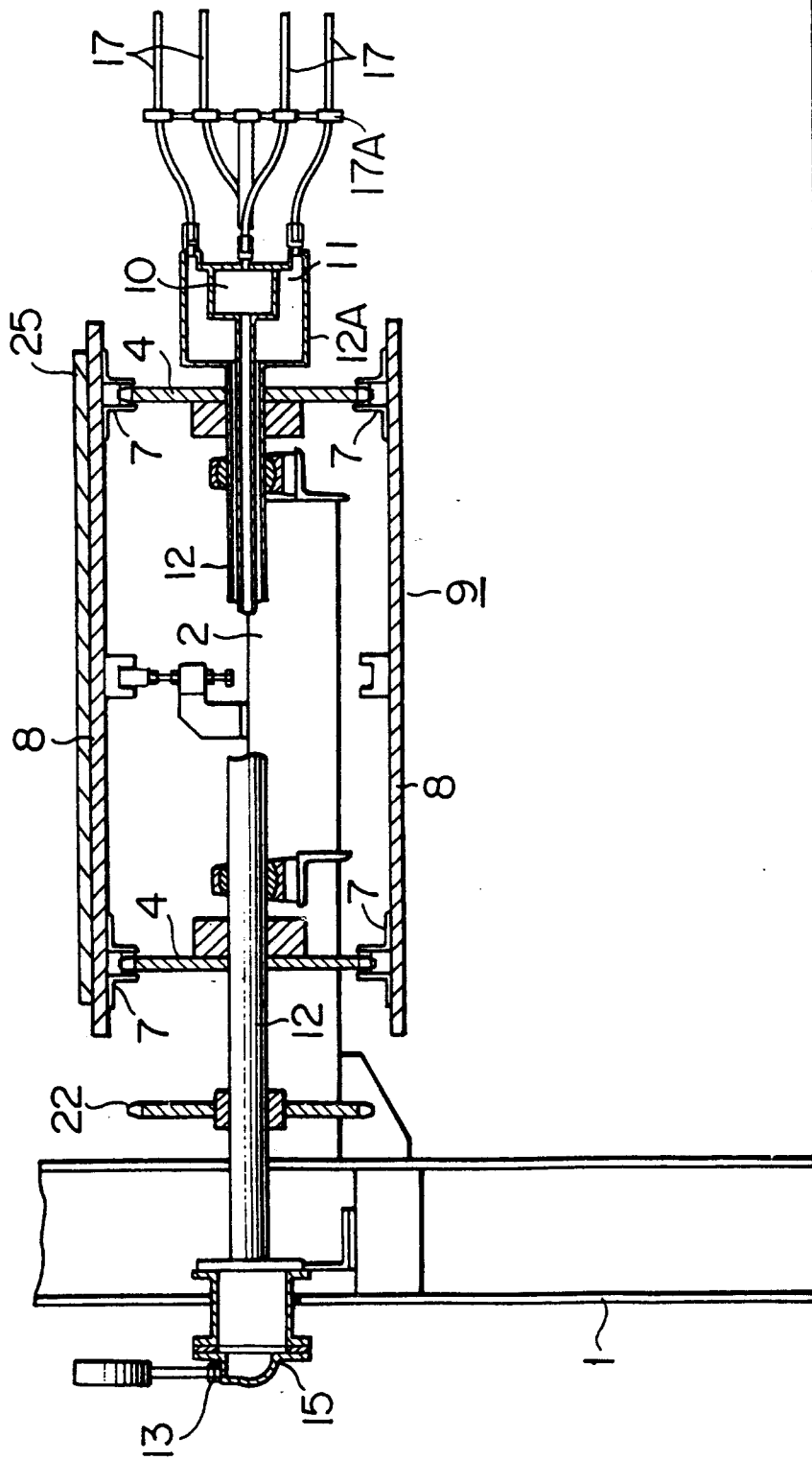

FIG. 3

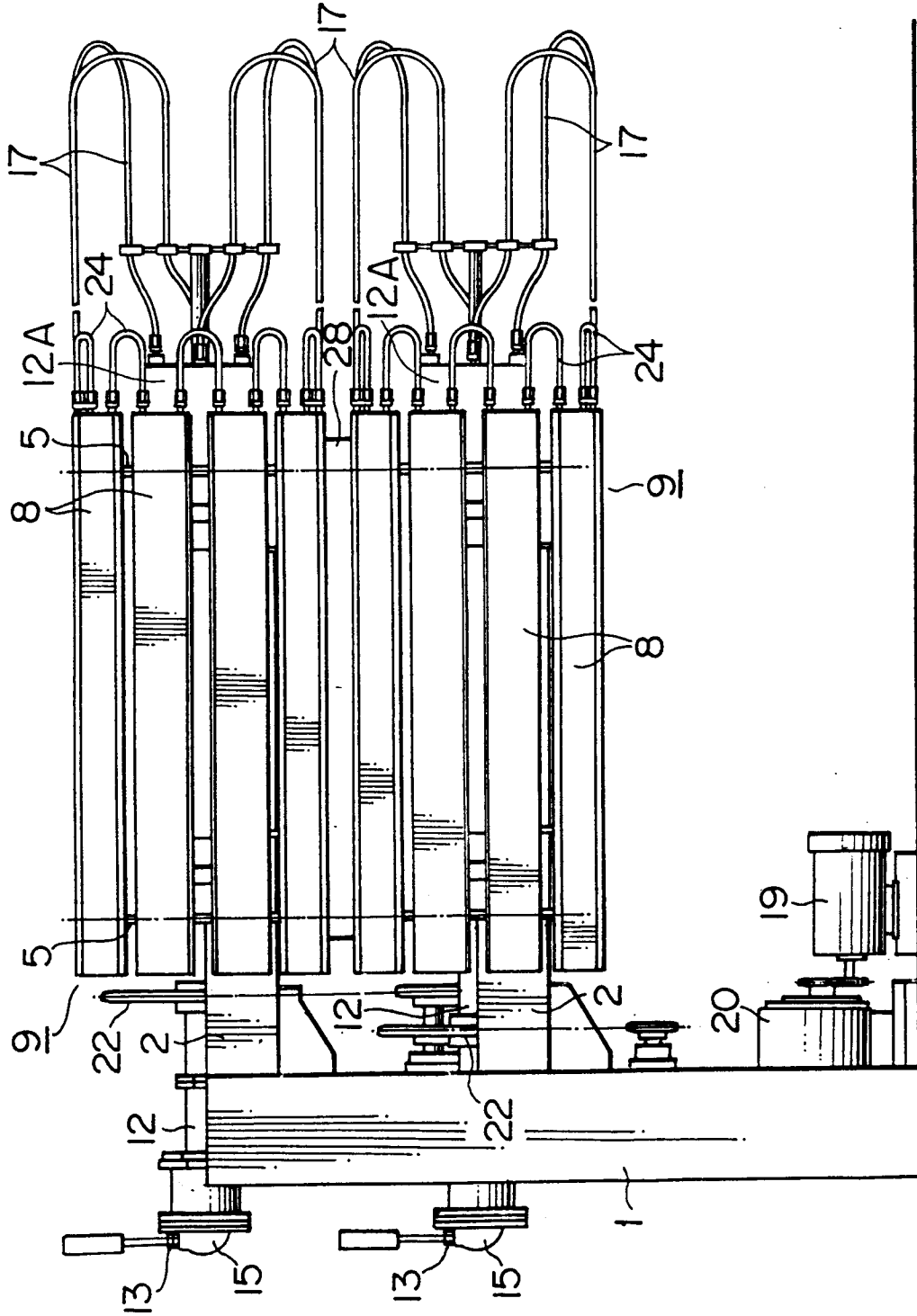
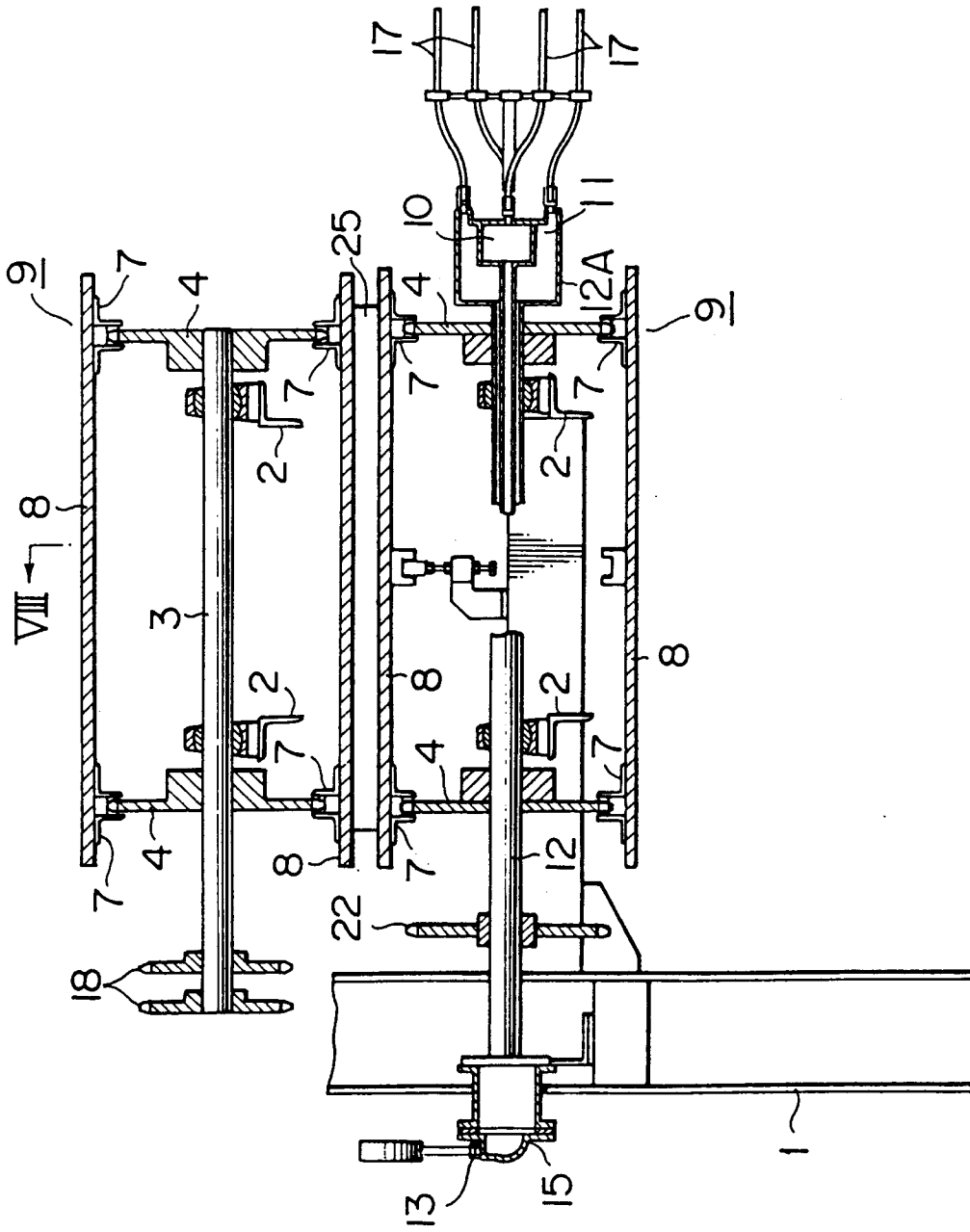

FIG. 4



VIII →
FIG. 5

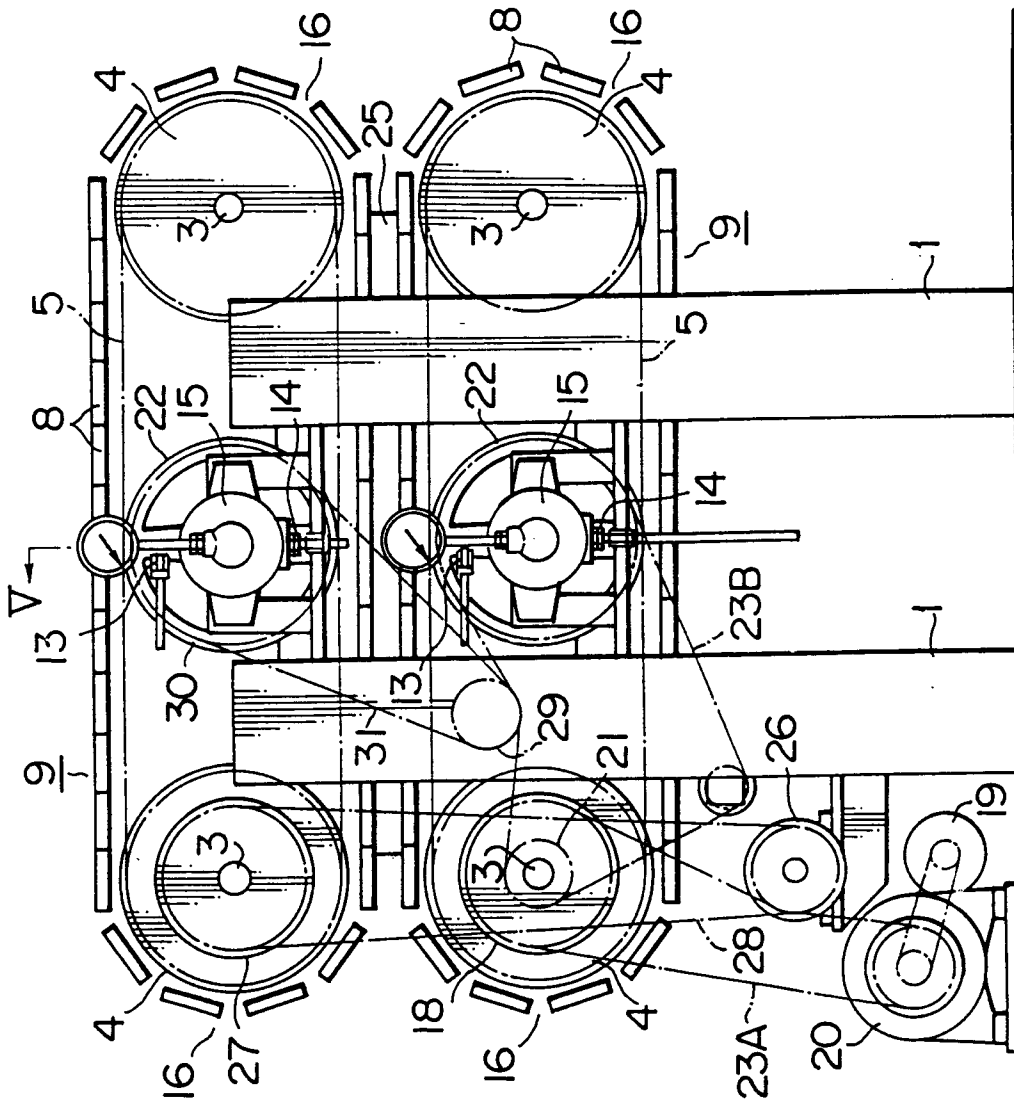

FIG. 6

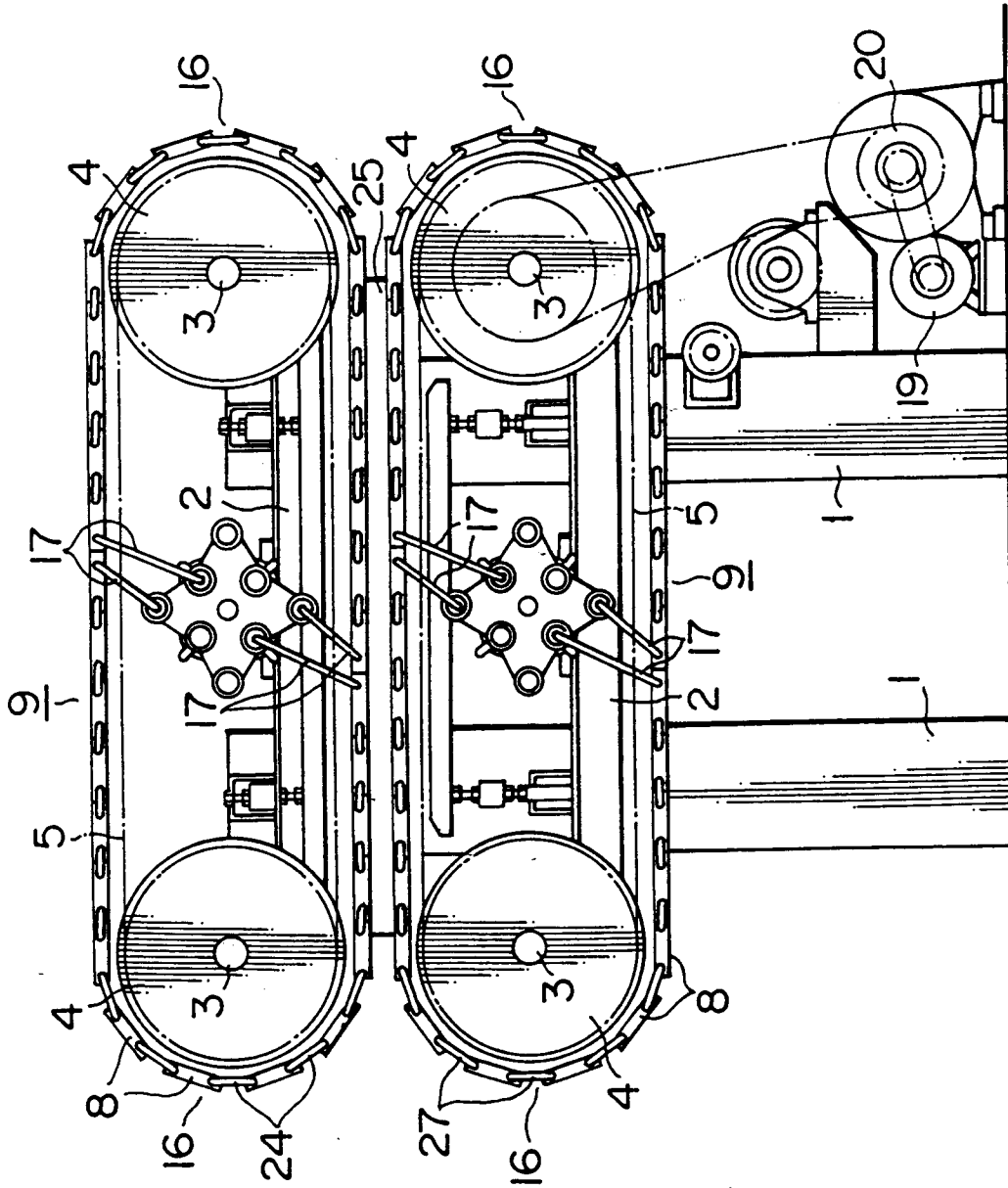

FIG. 7

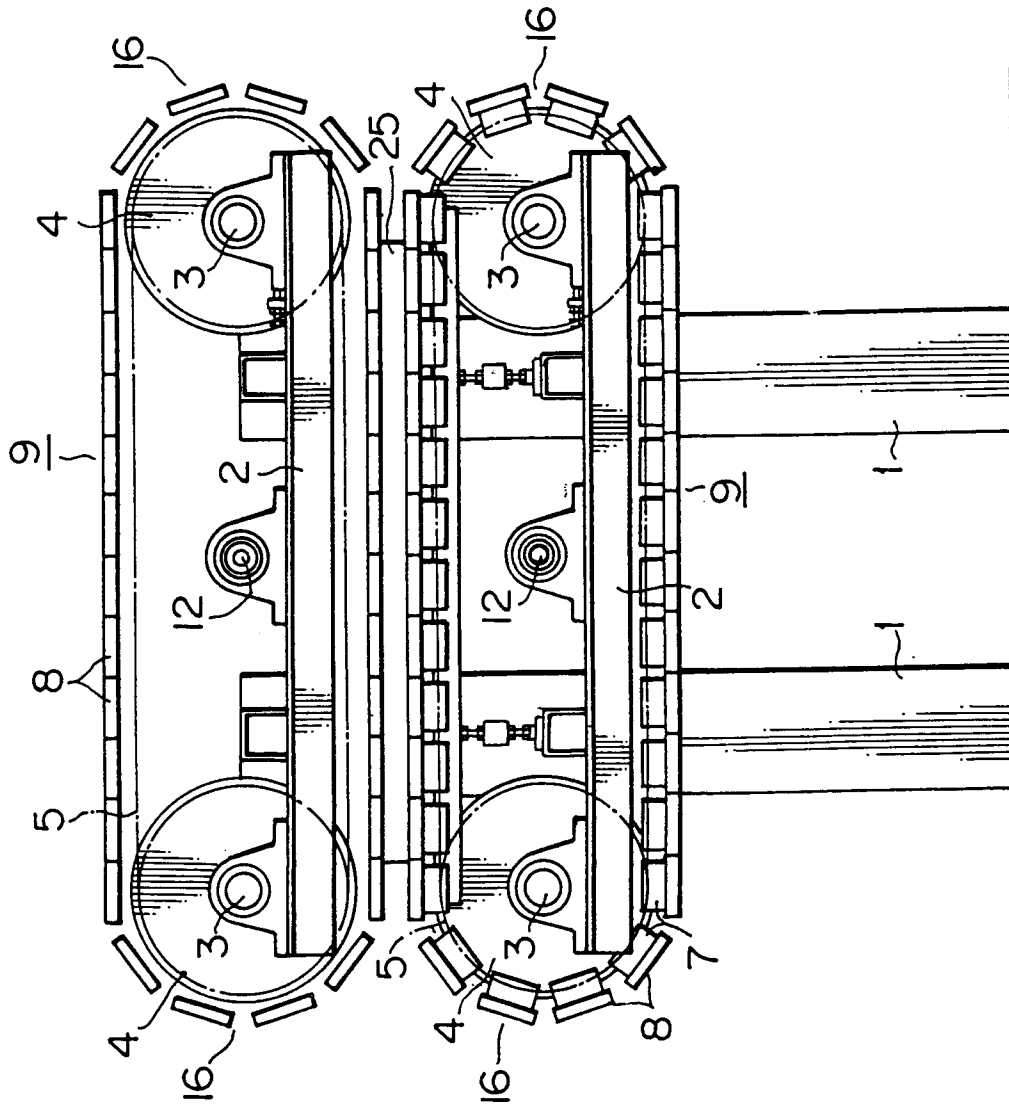

FIG. 8

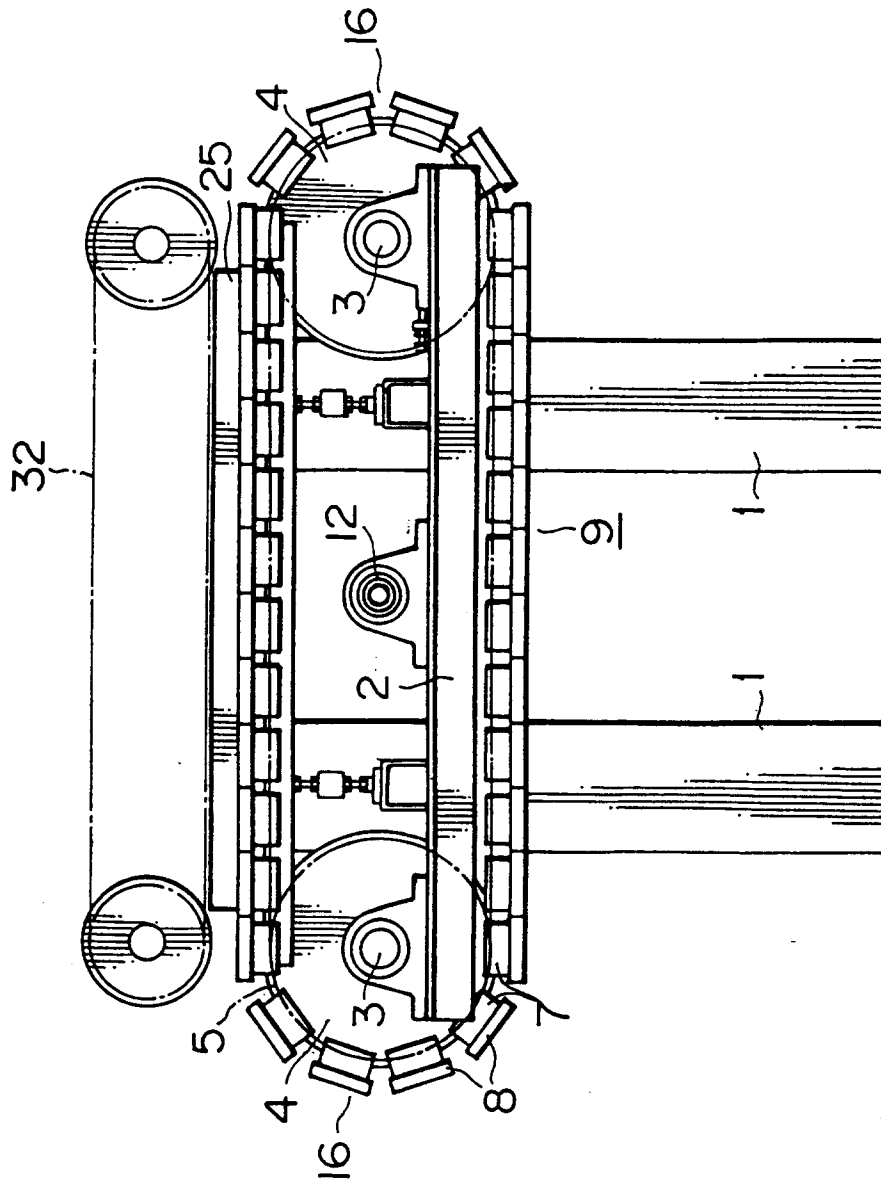

FIG. 9

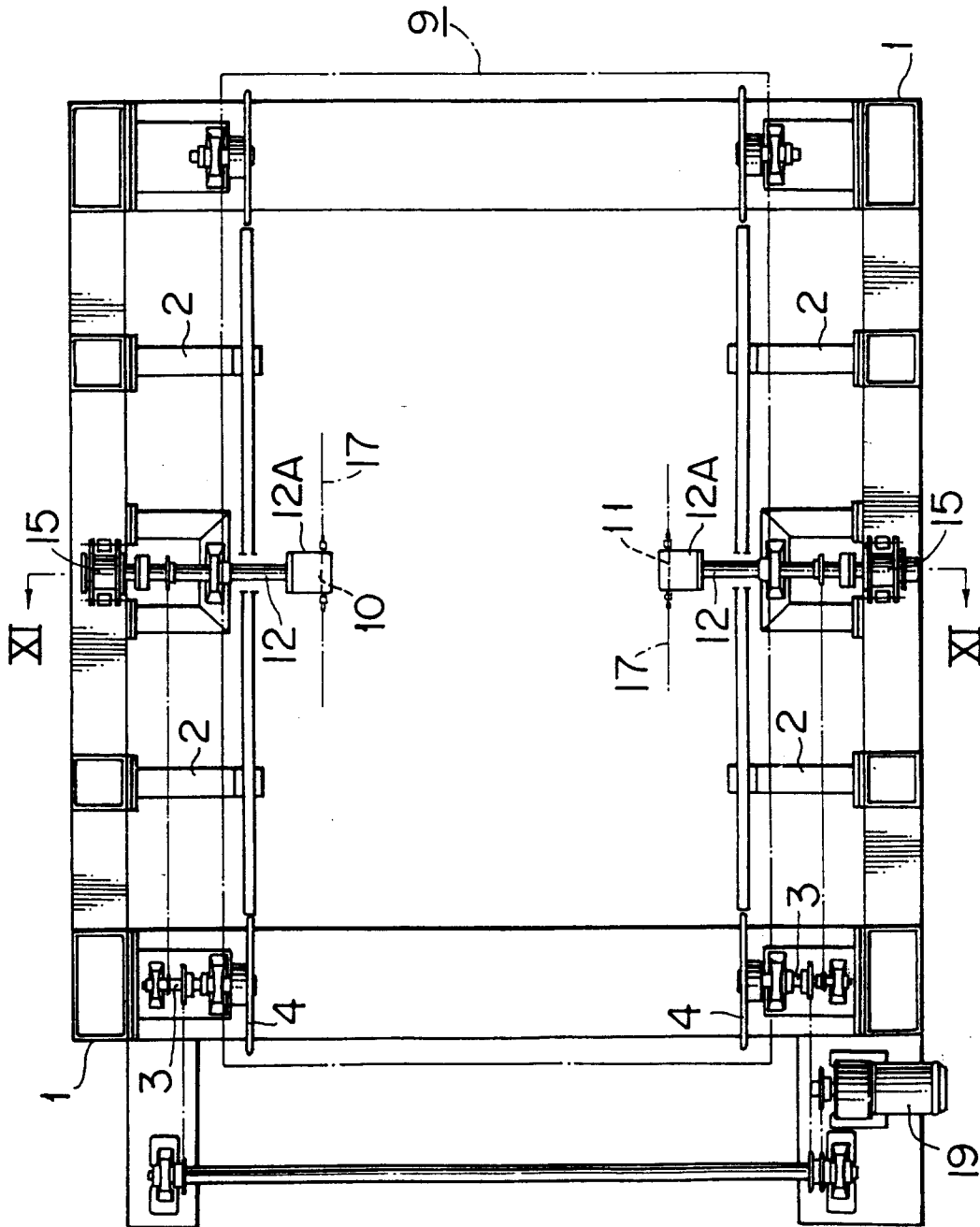

FIG. 10

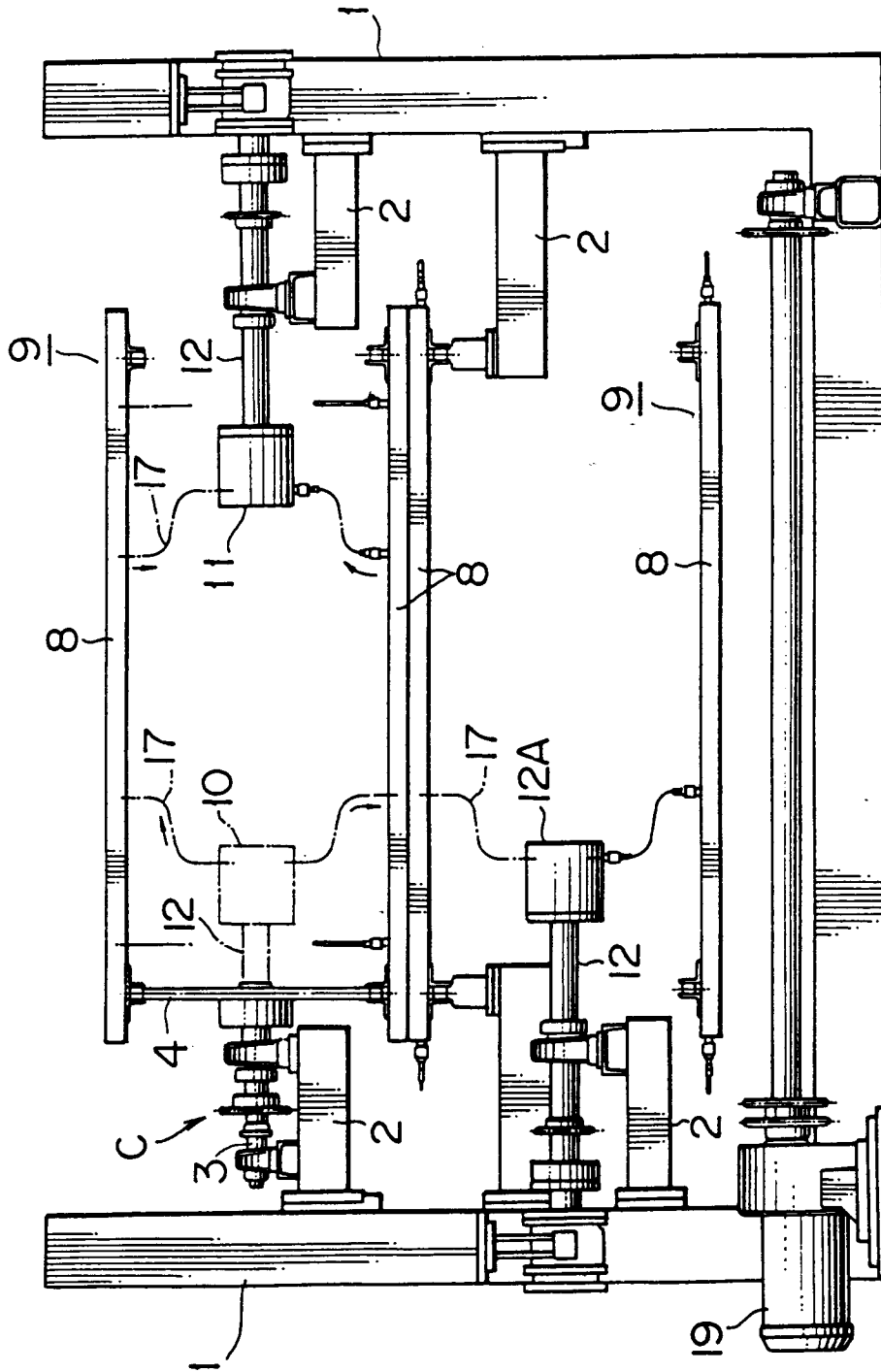

FIG. 11

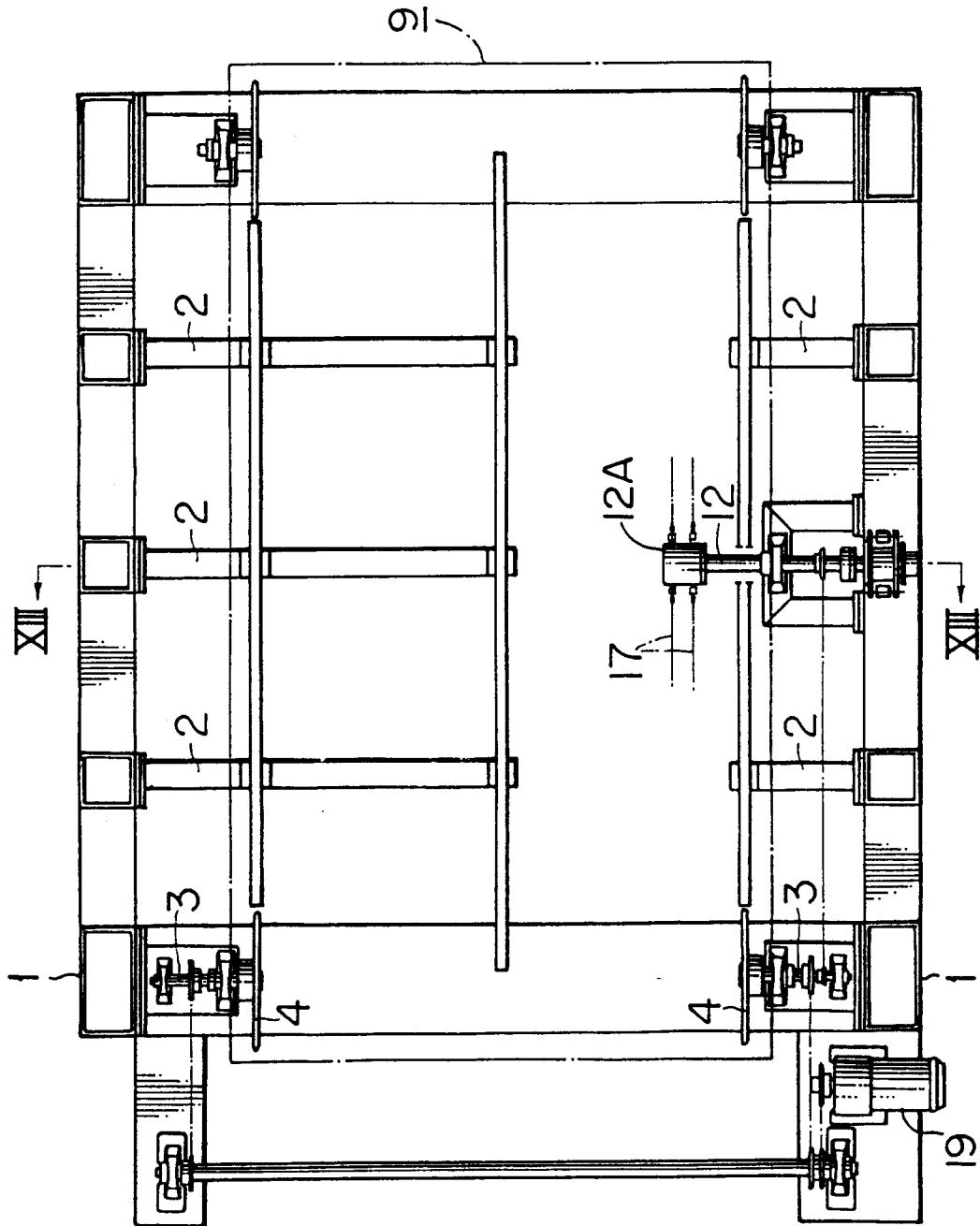

FIG. 12

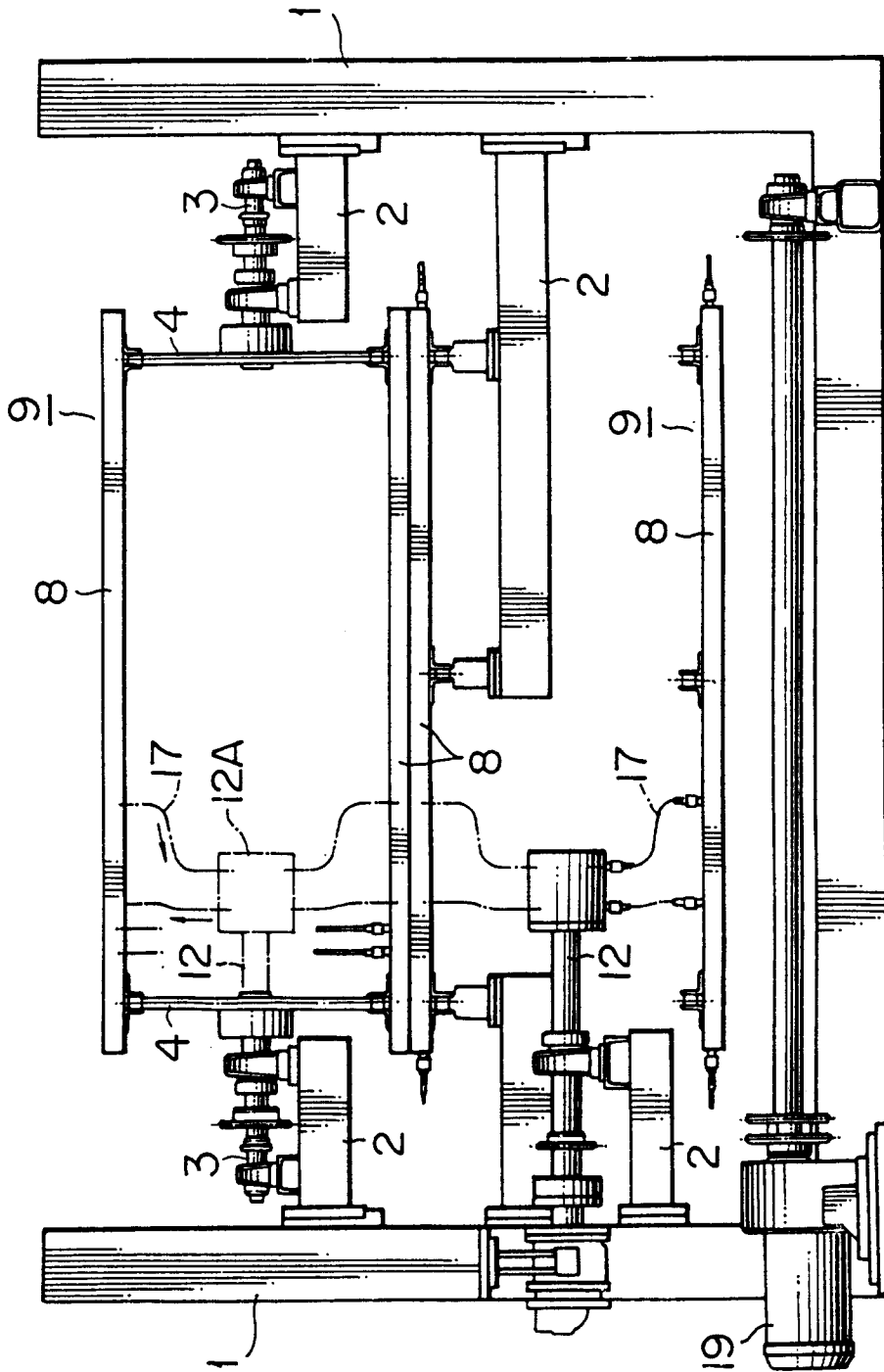

FIG. 13

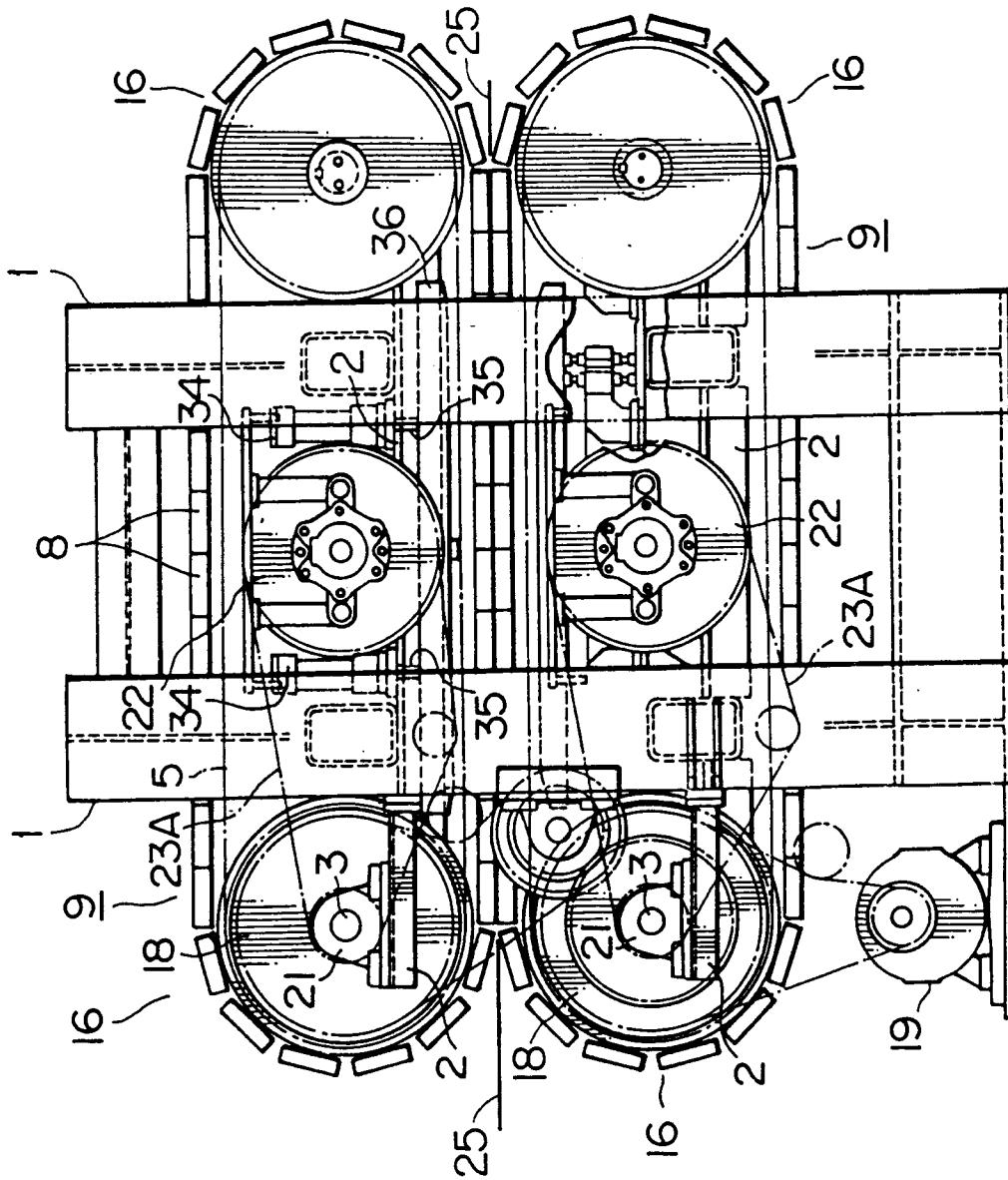

FIG. 14

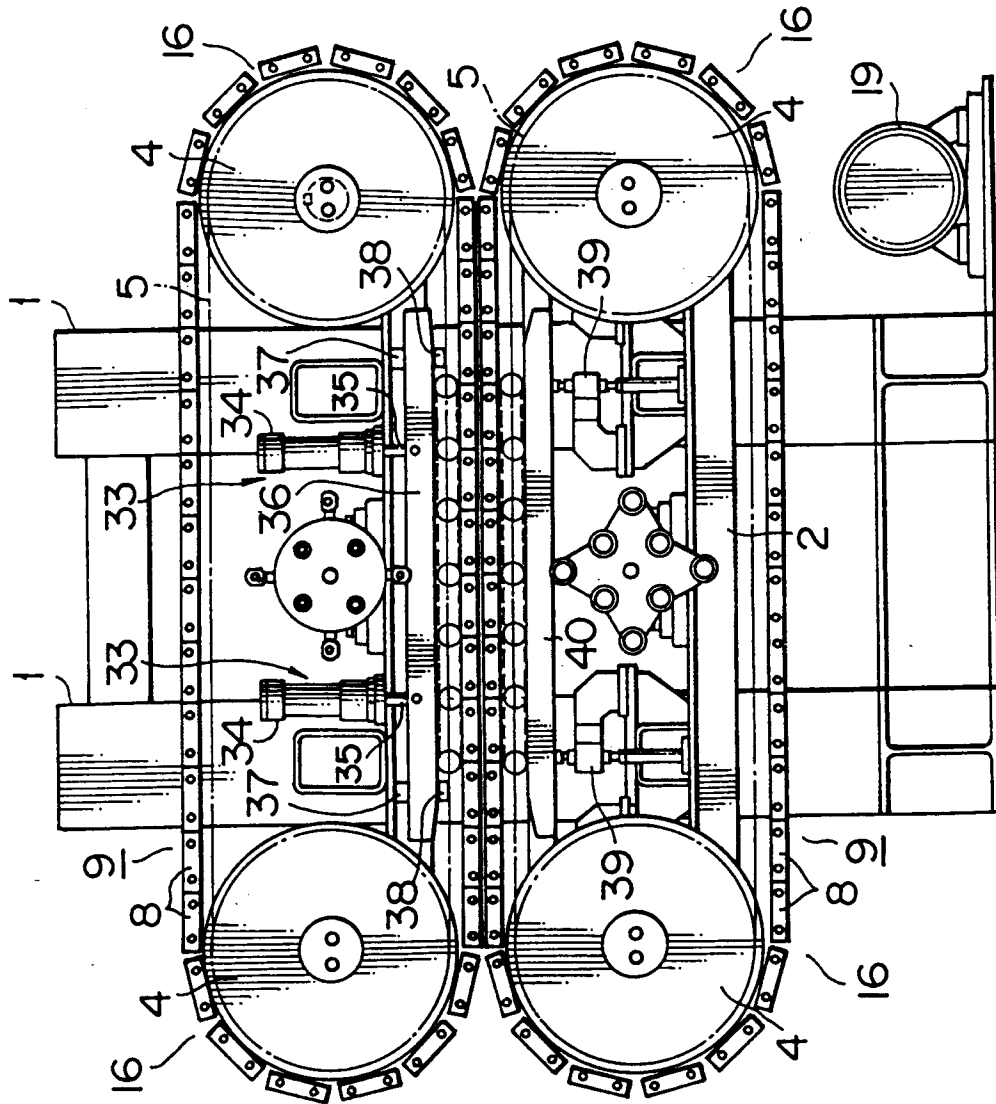

FIG. 15

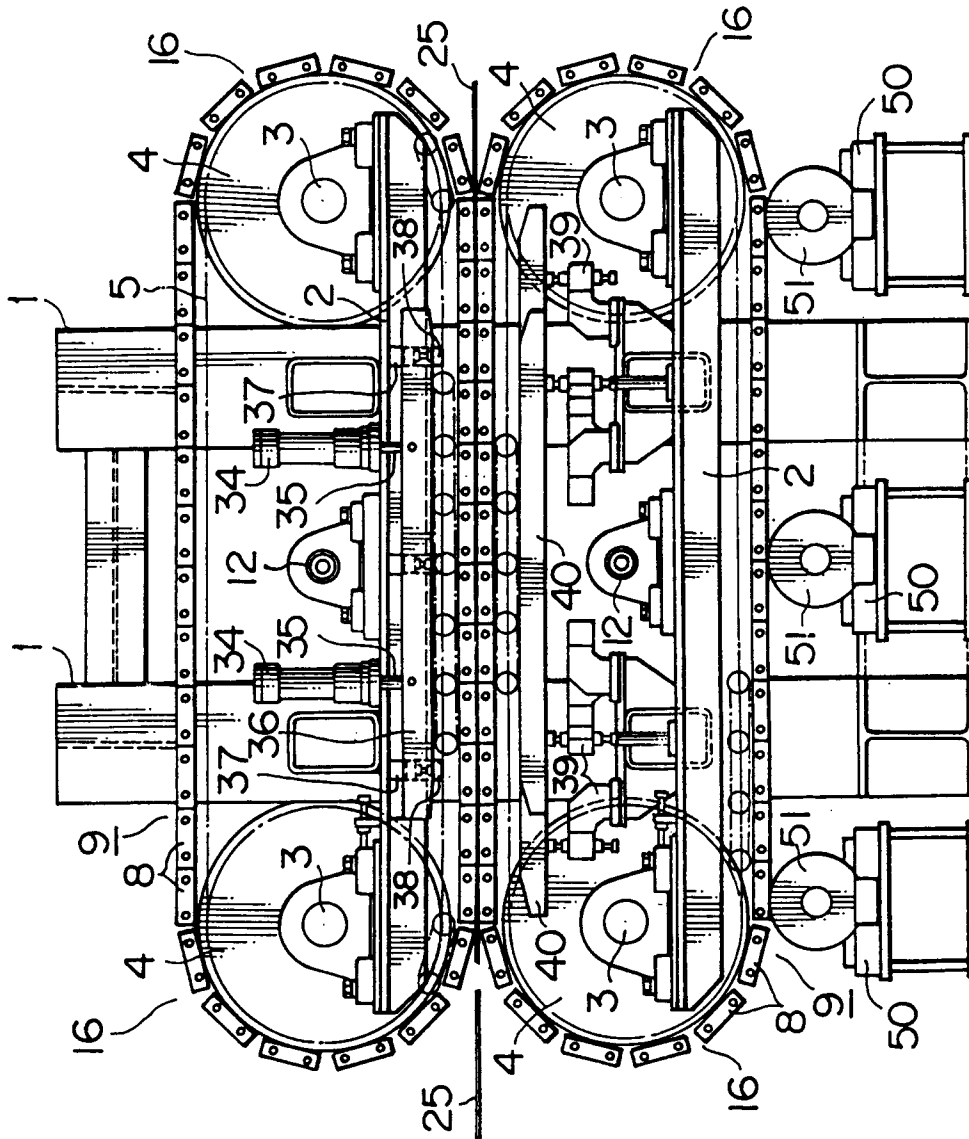

FIG. 16

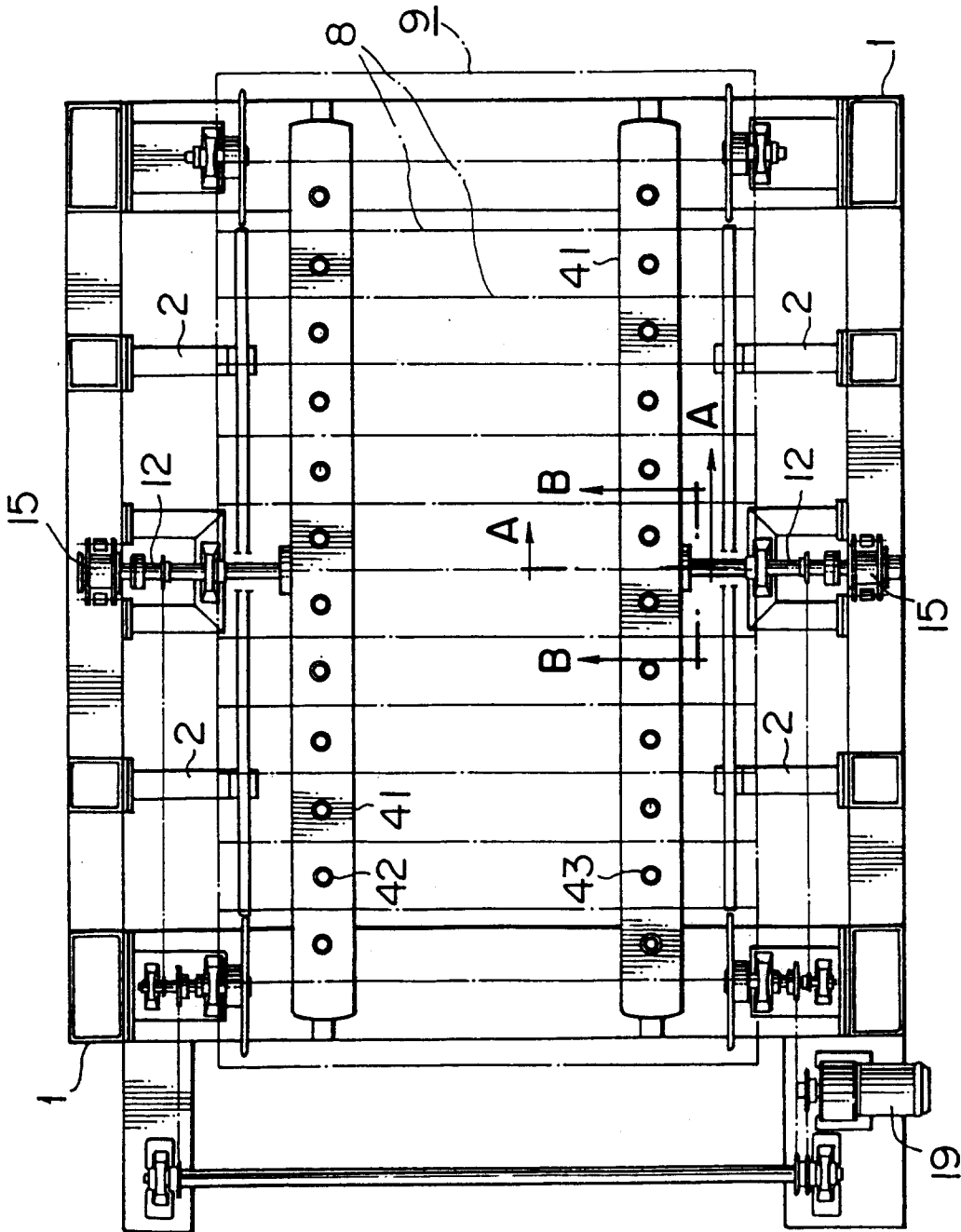

FIG. 17

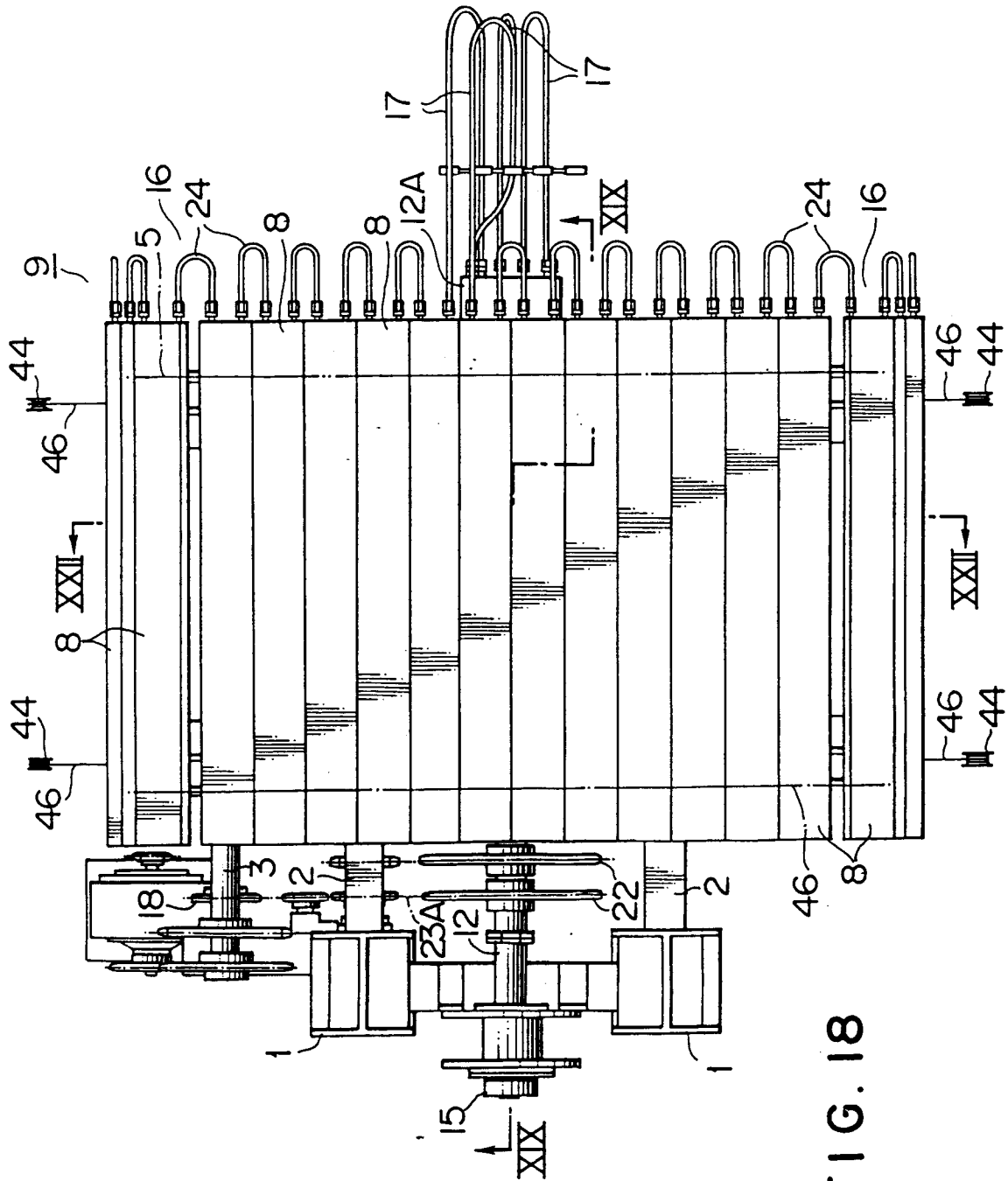

FIG. 18

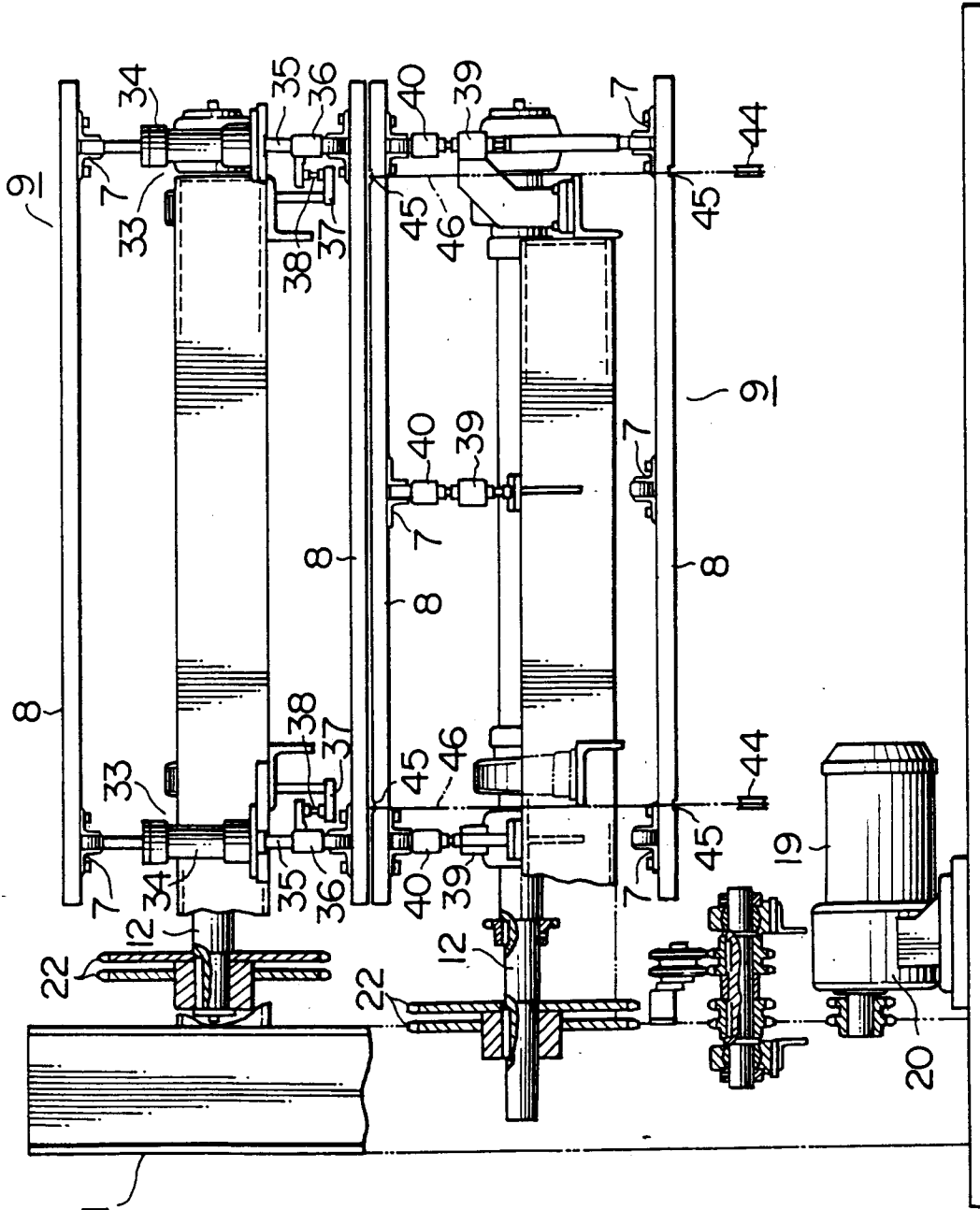

FIG. 19

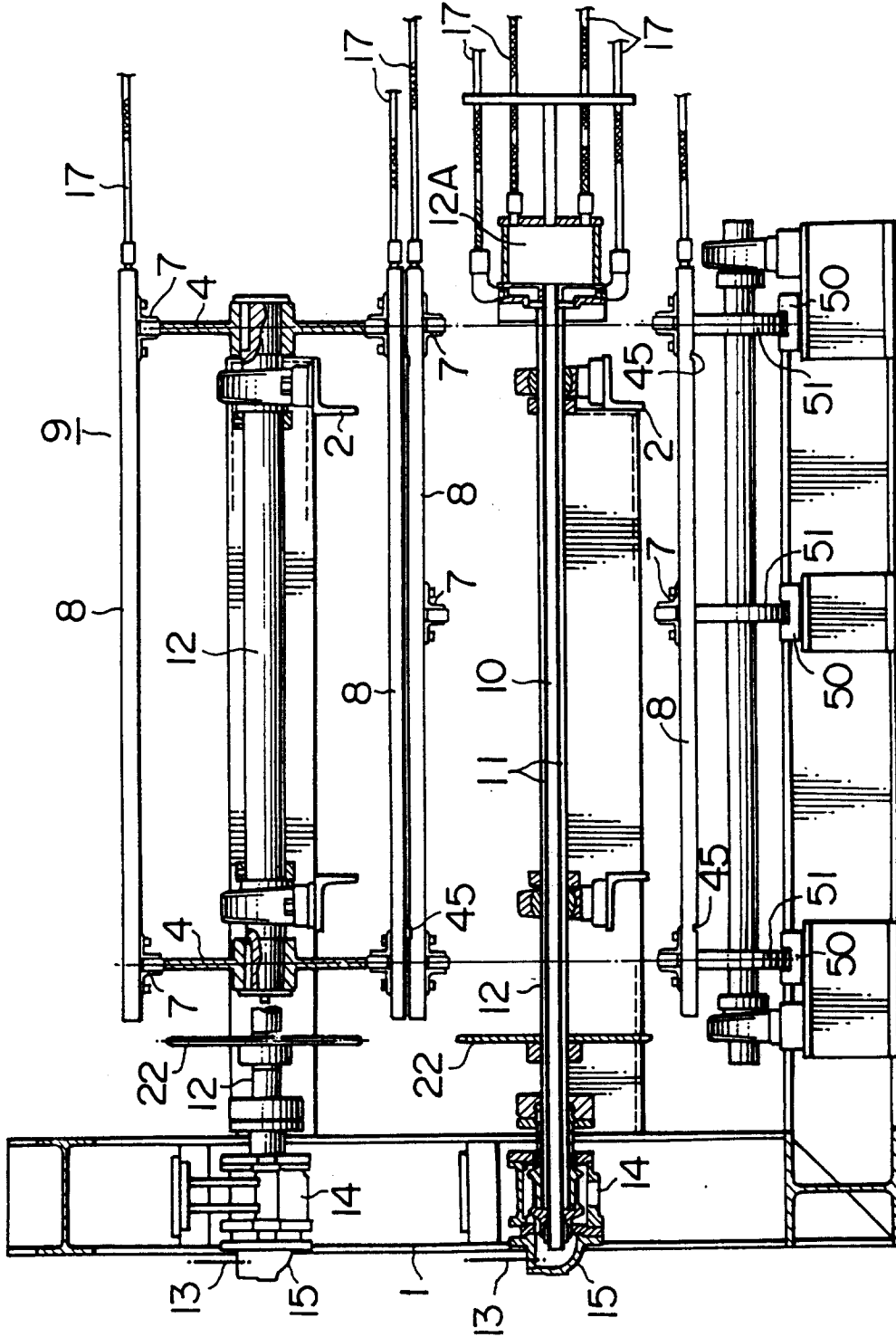

FIG. 20

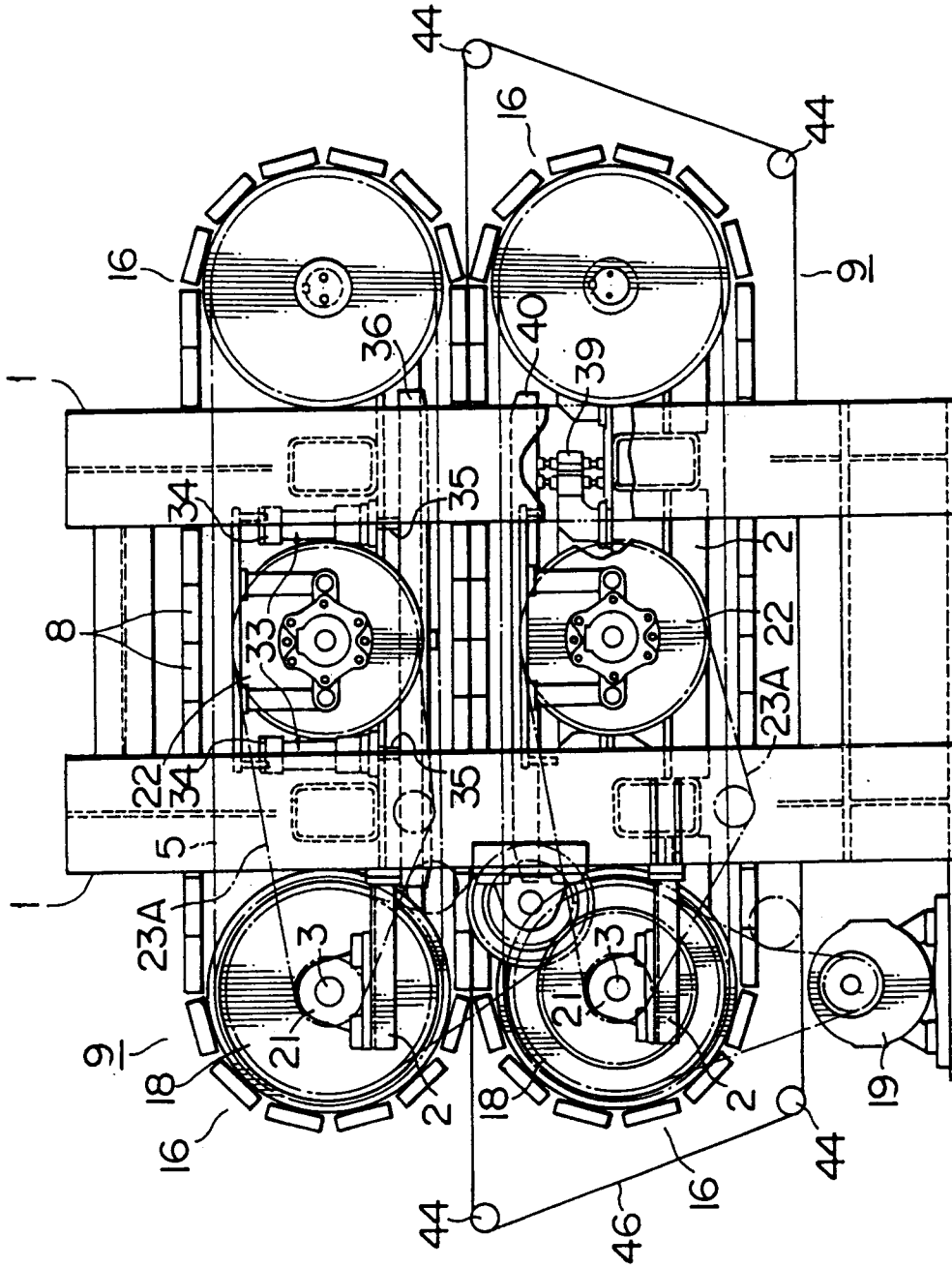

FIG. 21

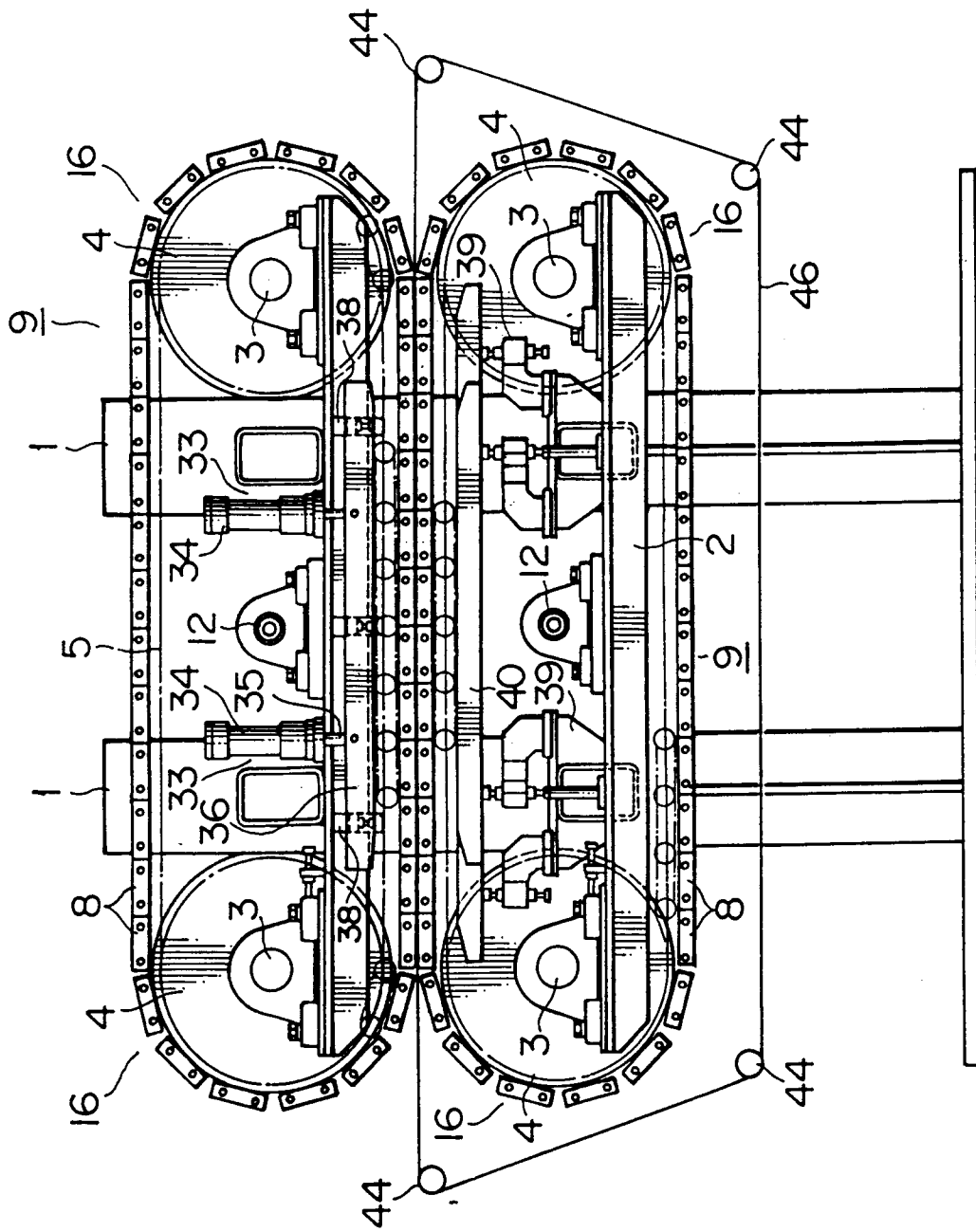

FIG. 22

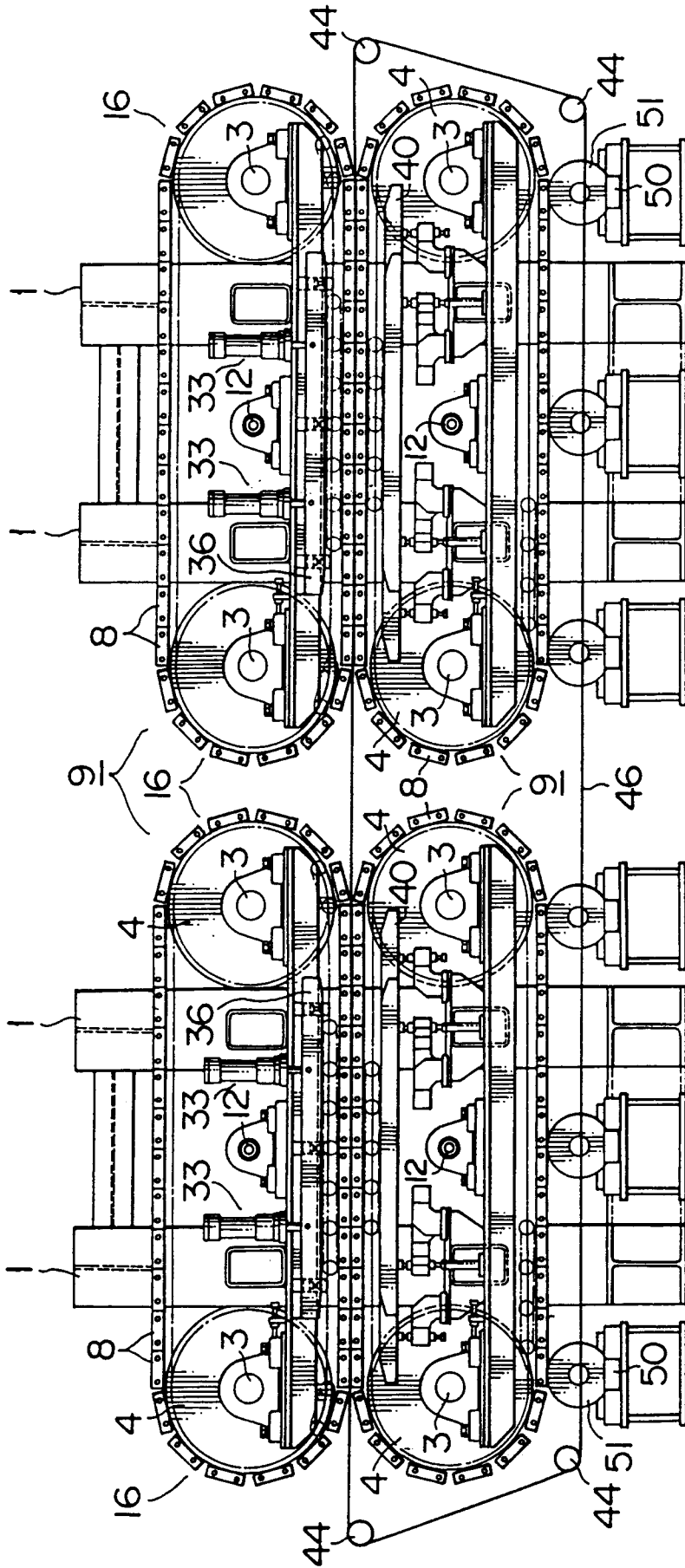

FIG. 23

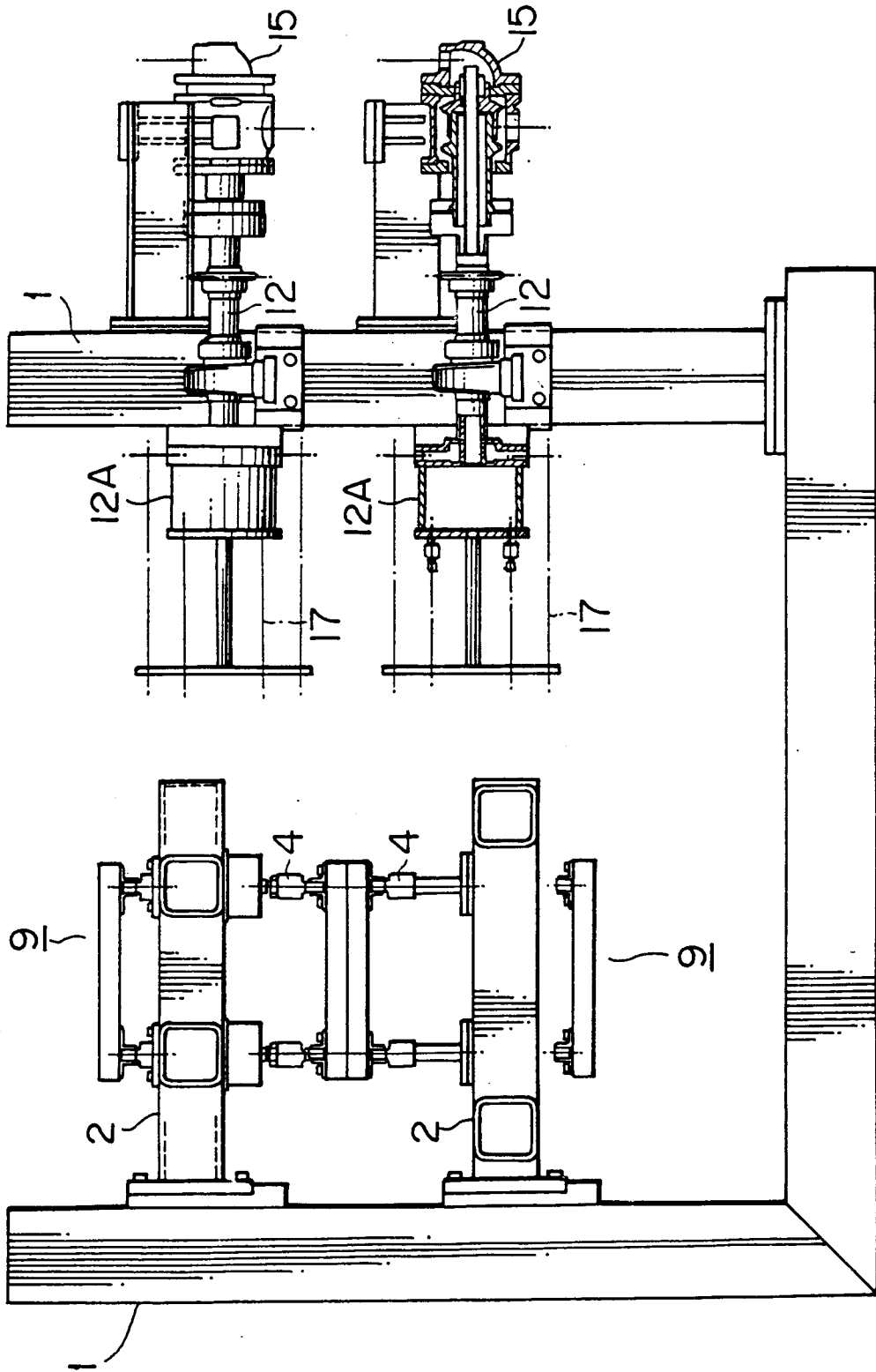

FIG. 25

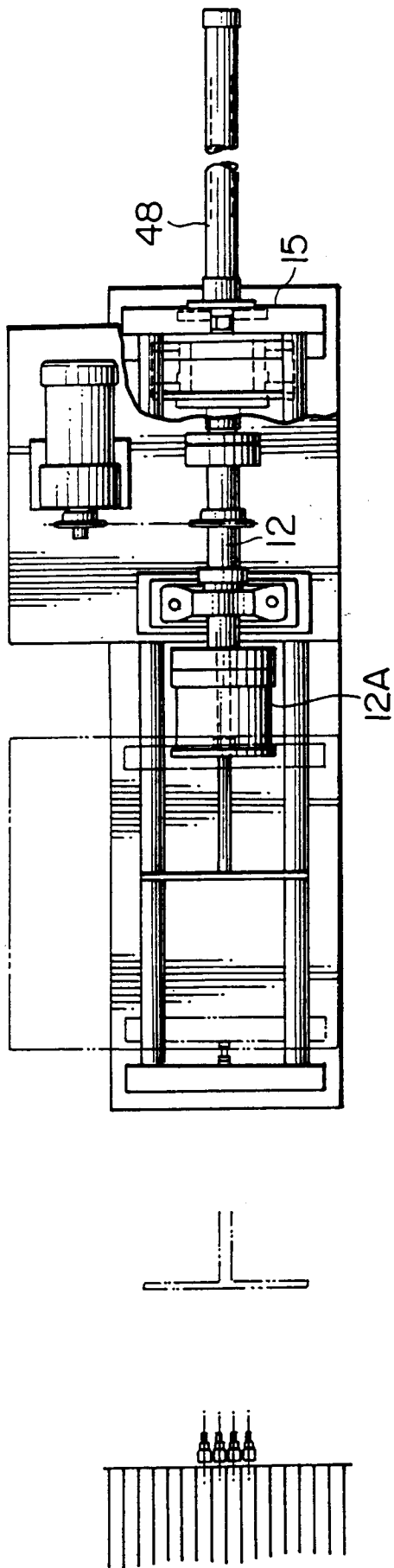

FIG. 26

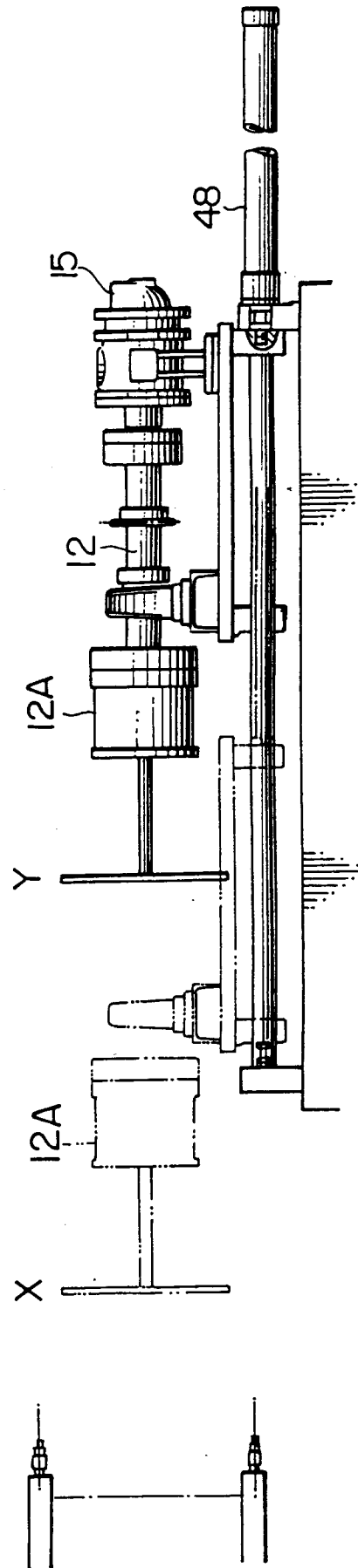

FIG. 27

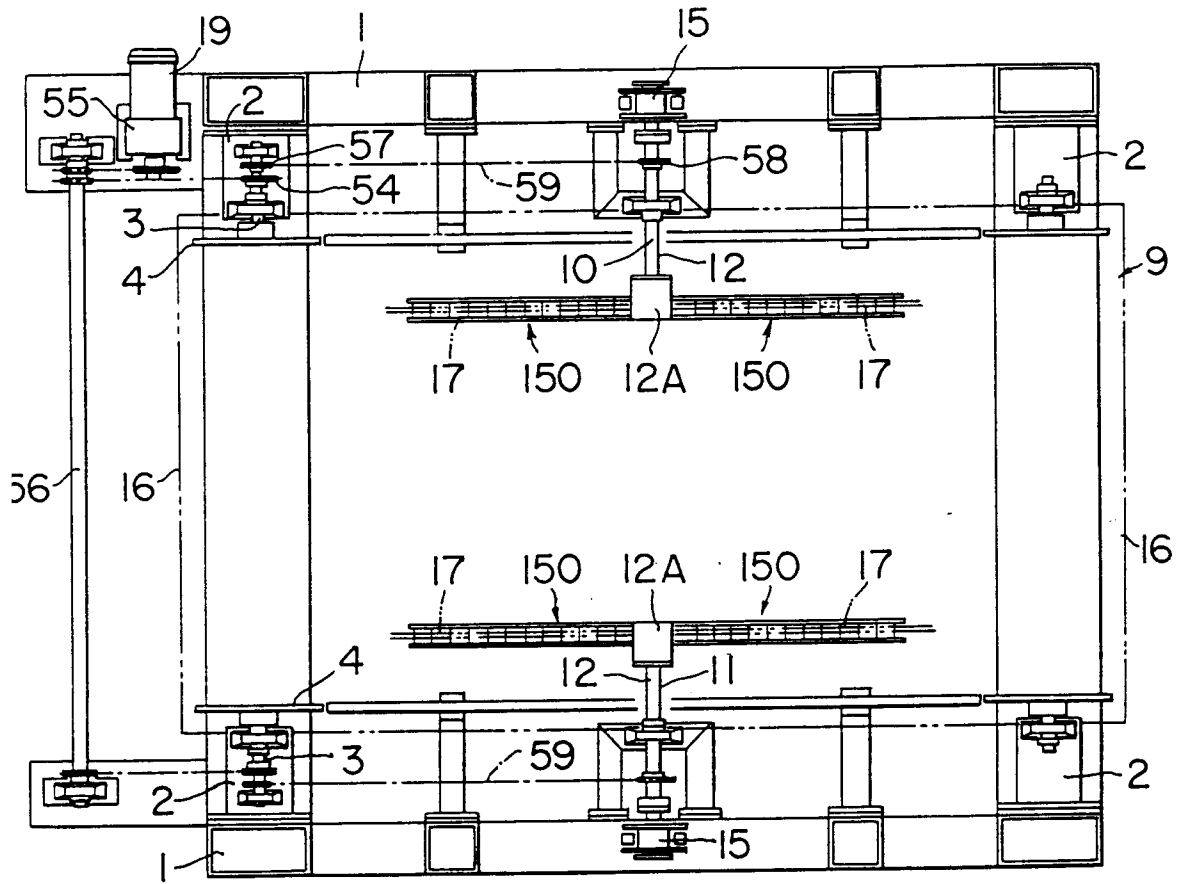

FIG. 28

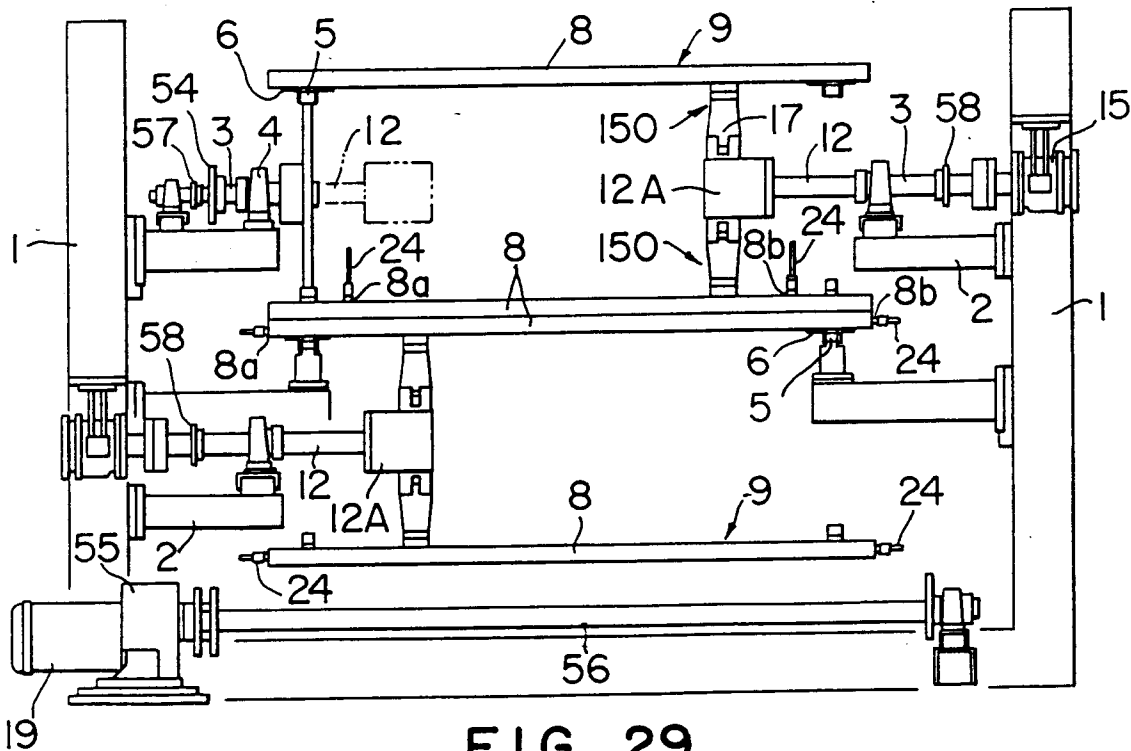

FIG. 29

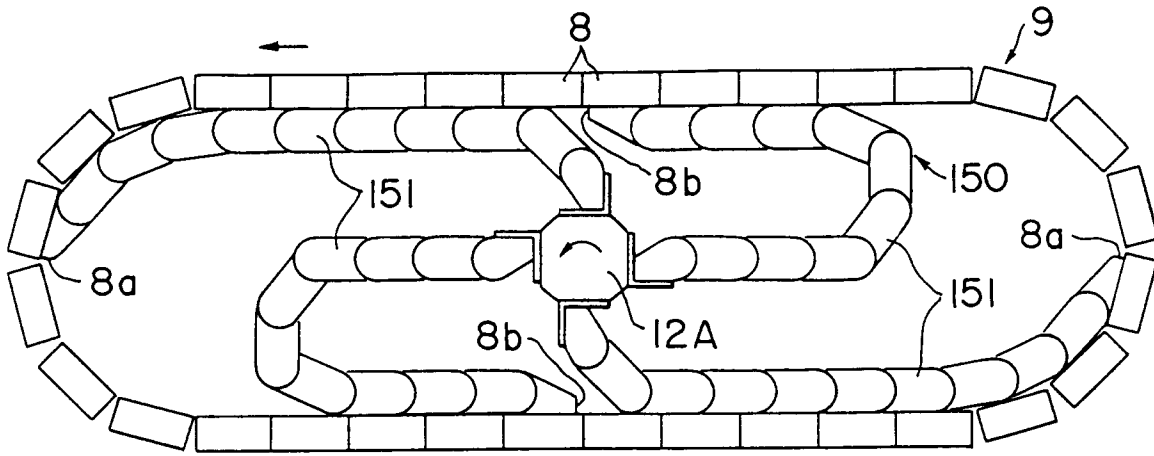

FIG. 30

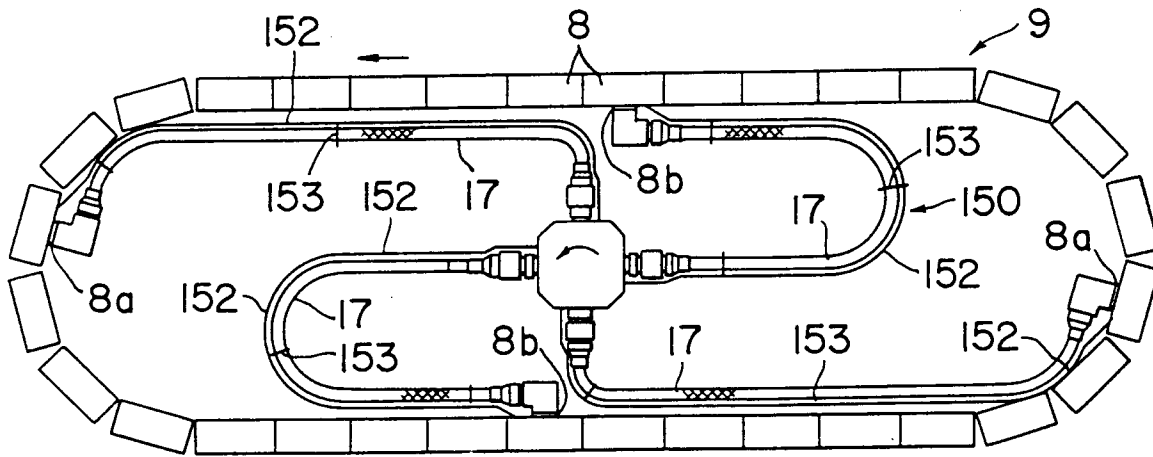

FIG. 31

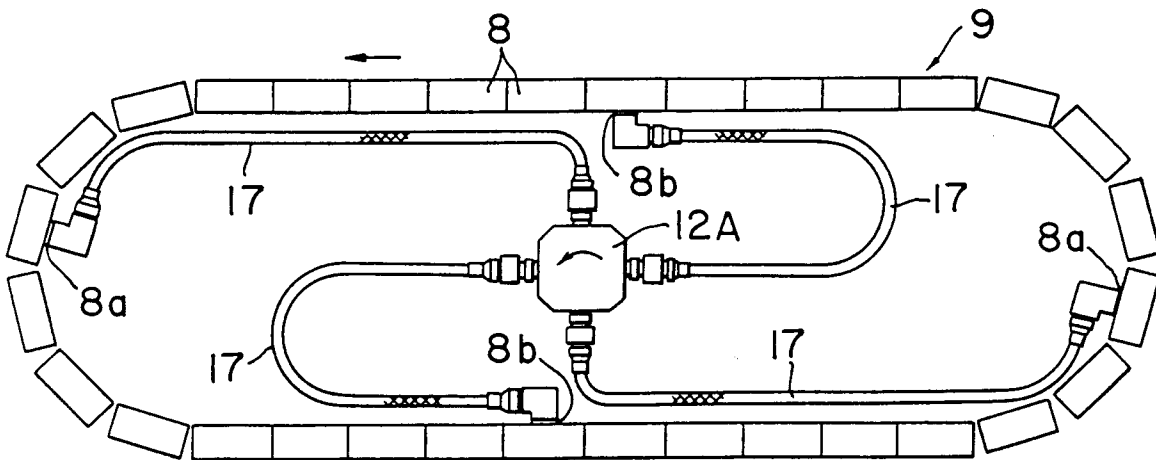

FIG. 32

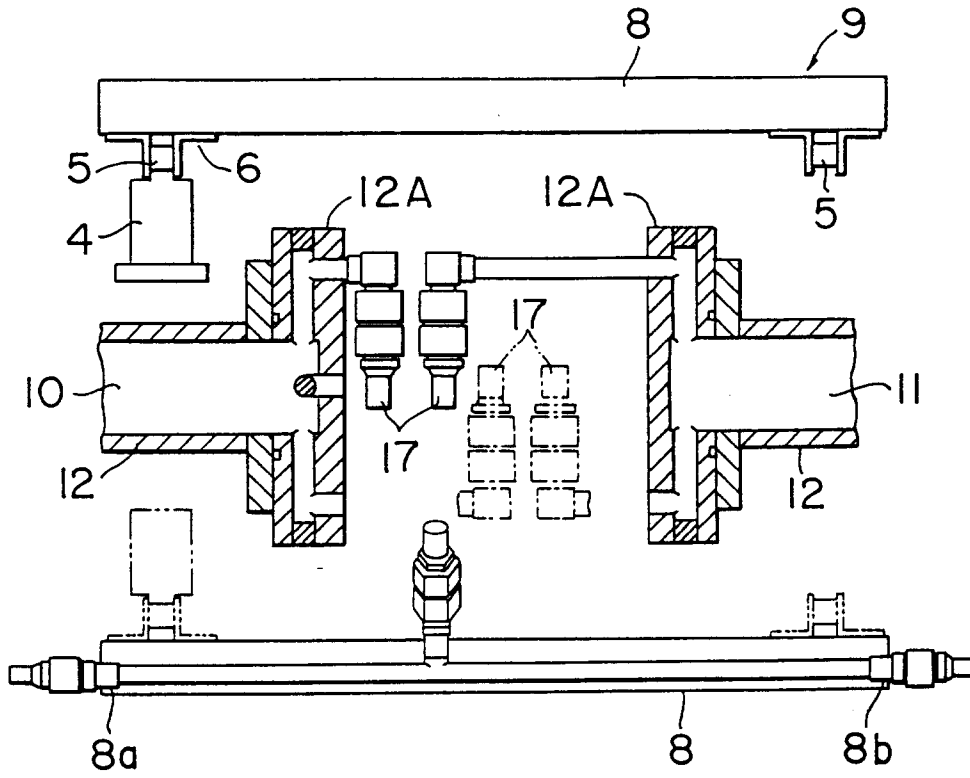

FIG. 33

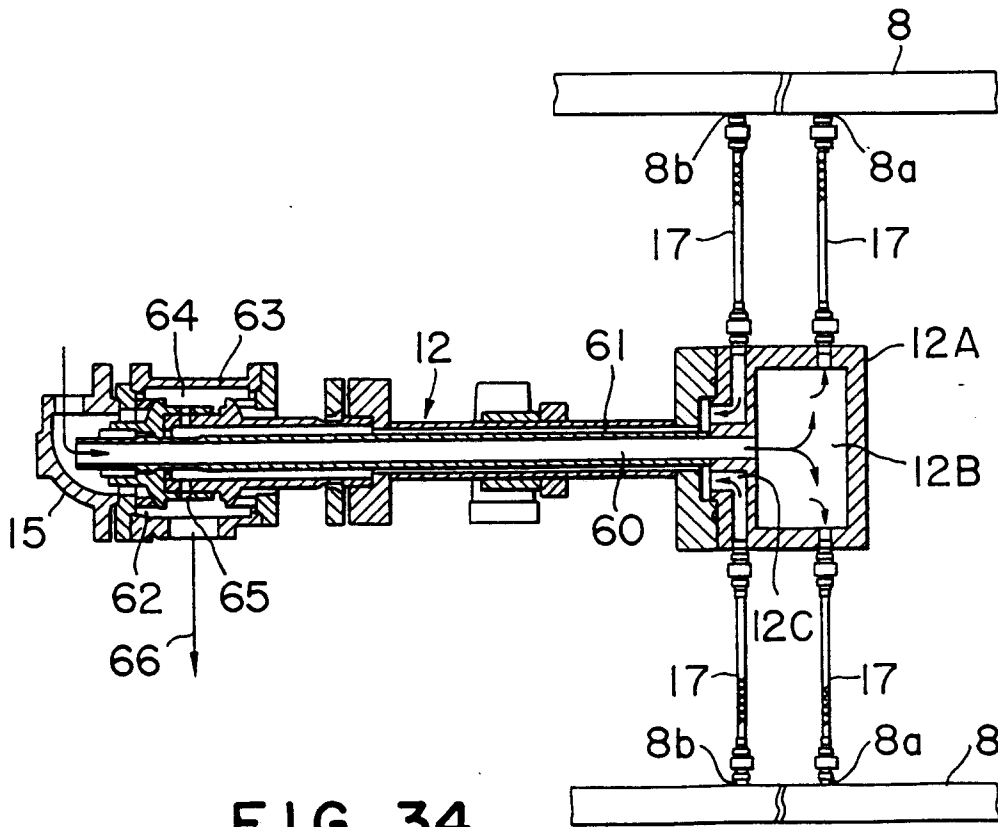

FIG. 34

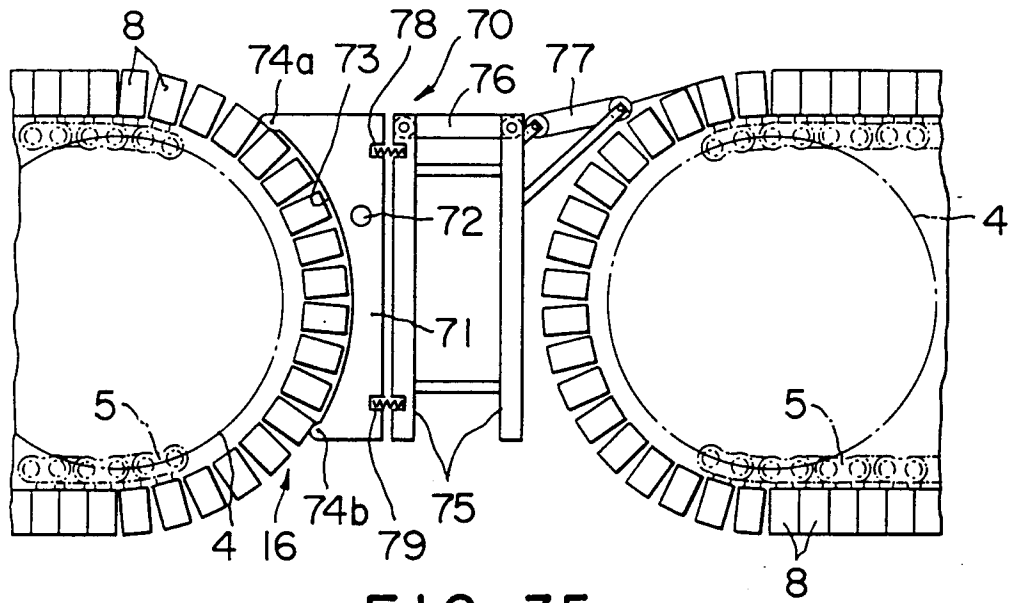

FIG. 35

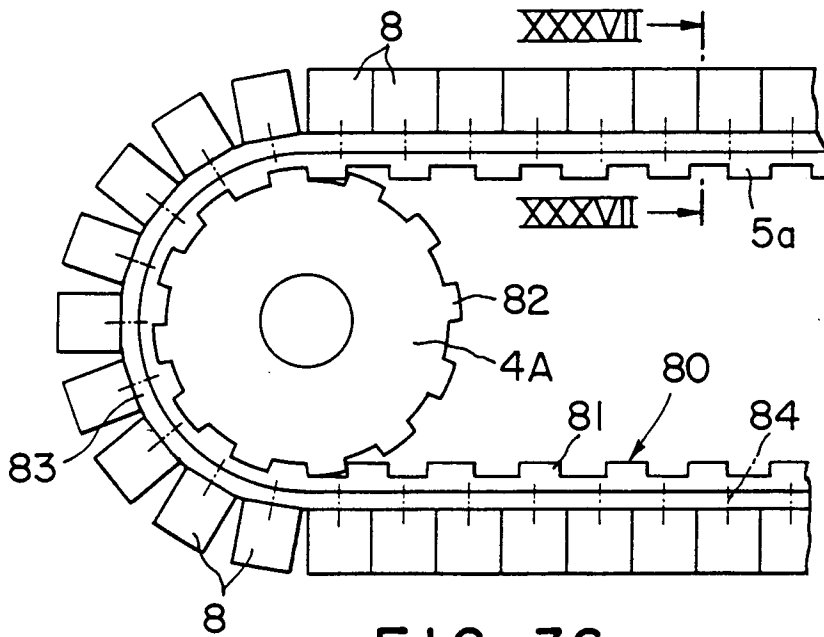

FIG. 36

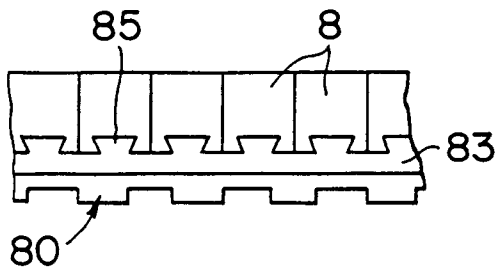

FIG. 38

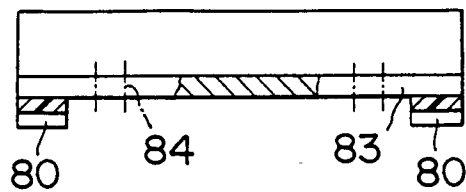

FIG. 37