



⑫

EUROPEAN PATENT APPLICATION

⑲ Application number : **91610038.1**

⑤① Int. Cl.⁵ : **E05B 17/10**

⑳ Date of filing : **02.05.91**

③① Priority : **03.05.90 DK 1104/90**

⑦② Inventor : **Nielsen, Frede**
11, Roskildevej
Tune, DK-4000 Roskilde (DE)

④③ Date of publication of application :
06.11.91 Bulletin 91/45

⑦④ Representative : **Siiger, Joergen et al**
c/o Chas. Hude H.C. Andersens Boulevard 33
DK-1553 Copenhagen V (DK)

⑧④ Designated Contracting States :
AT BE CH DE ES FR GB GR IT LI LU NL SE

⑦① Applicant : **ANTONSON SECURITY DENMARK**
A/S
15, Metalgangen
DK-2690 Karlslunde (DK)

⑤④ **A lock for an antitheft device.**

⑤⑦ An antitheft device for marking articles for sale and comprising two members, which automatically interlock one another when one member is inserted in a cavity in the other member, the first member being a rod-shaped body (1) with a completely or partially pointed insertion end, whereby said rod-shaped body (1) is capable of engaging for instance balls loosely arranged in the cavity of the second member, a third member (8) of magnetizable material being inserted below the loosely arranged balls (6), whereby a resilient member (10) with an upwardly directed force is placed below said third member (8). According to the invention the resilient member (10) is an annular plastic member with inward connecting parts (10') connected to a centrally arranged disk-shaped plastic member (10') pressing against the third member (8) in the cavity, the annular plastic member (10) being secured by way of squeezing to an annular groove (11) in the bottom of the housing (16). As a result, the assembling of the members of the lock is facilitated and the bottom and the spring can be formed in one piece. An additional cavity may be provided around the cavity of the lock, said additional cavity containing a colored liquid.

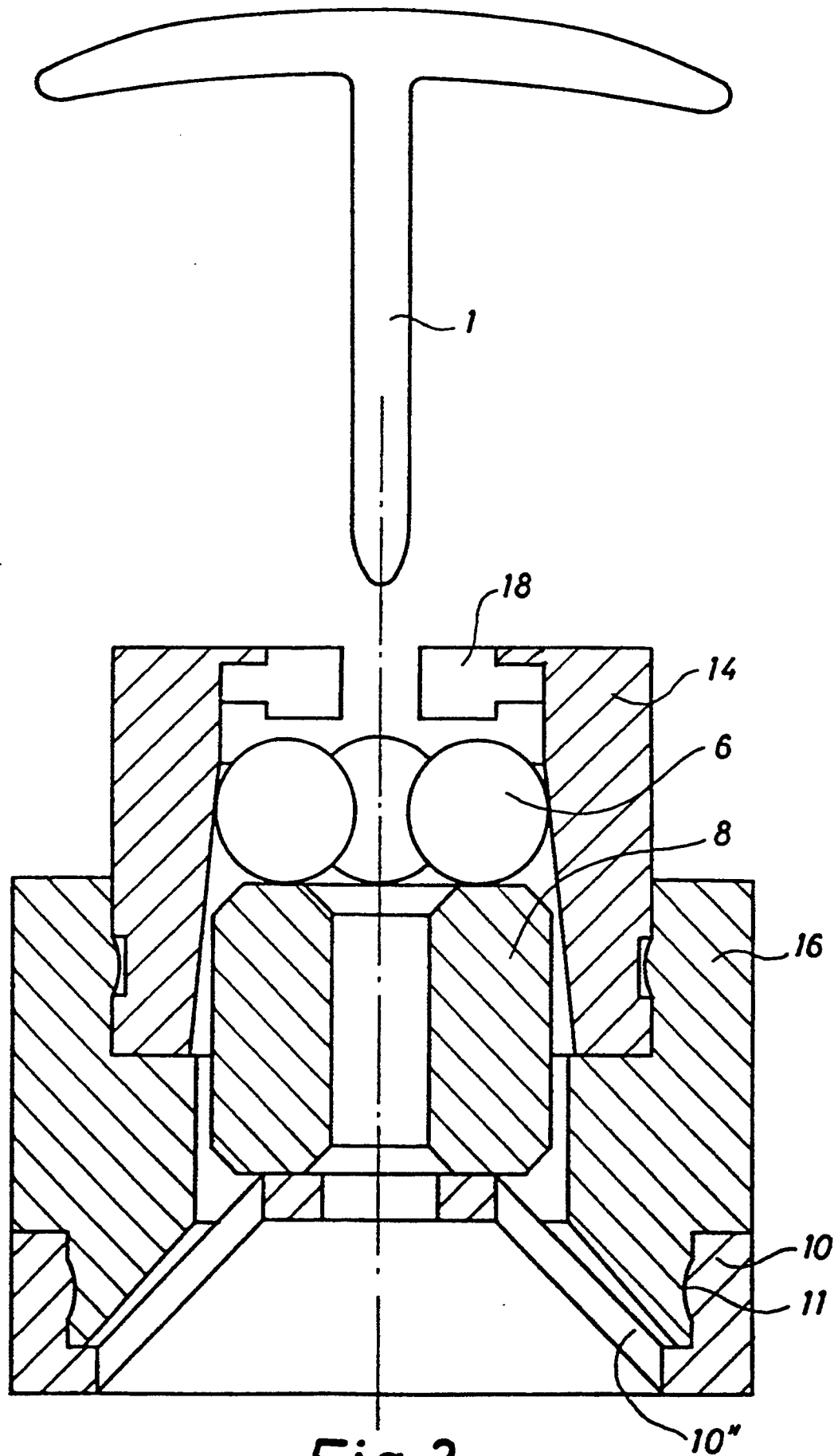

Fig. 2

The invention relates to a lock for an antitheft device for marking articles for sale and comprising two members, which automatically interlock one another when one member is inserted in a cavity in the other member, the first member being a rod-shaped body with a completely or partially pointed insertion end, whereby said rod-shaped body is capable of engaging for instance balls loosely arranged in the cavity of the second member, a third member of magnetizable material being inserted below the loosely arranged balls, where a resilient member with an upward driving force is placed below said third member.

US-PS No. 3,858,280 discloses a locking device, where the cavity of one member contains retaining balls for a rod-shaped body. The cavity contains furthermore a retaining member pressing the balls against the side wall by means of a spring. The spring is supported by a retaining ring in the bottom of the housing. The retaining ring is relatively difficult to mount in a groove in the inner side of the cavity.

German Auslegeschrift No. 2,548,546 discloses furthermore a lock for an antitheft device. The lock comprises a pin-like insertion member insertable in a cavity housing a cone-shaped body. The cone-shaped body is pressed outwards by means of a spring inserted in the cavity. The cone-shaped body comprises some balls pressing against the insertion member when said body is subjected to a pull. The lock comprises a relatively large number of parts with the result that it is difficult to assemble. In addition, it is necessary to process the surface of the lock in order to avoid corrosion.

The lock according to the invention is characterized in that the resilient member is an annular plastic member with inward connecting parts connected to a centrally arranged disk-shaped plastic member pressing against the third member in the cavity, said annular plastic member being secured to an annular groove in the bottom of the housing by way of squeezing. The resulting lock comprises fewer parts compared to known locks because the bottom and the spring are formed in one piece. Accordingly, the lock is easier to assemble than the known locks.

The invention is described in greater details below with reference to the accompanying drawings, in which

Figure 1 illustrates an antitheft device with a lock according to the invention,

Figure 2 is a sectional view of the lock,

Figure 3 is a bottom and side view, respectively, of the bottom part of the lock, and

Figure 4 illustrates a particularly advantageous embodiment of a release magnet.

The antitheft device of Figure 1 for marking articles for sale comprises a first member with a shell in form of a top portion 2 and a bottom portion 4. The portions are for instance made of plastics and are sec-

ured to one another for instance by way of gluing. A centrally arranged cavity and a circumferential cavity 5 are defined between the portions 2 and 4. The centrally arranged cavity contains one part of the lock, an opening 7 being provided in the bottom portion 4 of the device for the insertion of the second member of the lock. The second member of the lock is a rod-shaped body in form of a pin-like fastening means 1. The circumferential cavity 5 contains a coil and a capacitor adjusted to a desired resonant frequency and is detected when the antitheft device passes a detection zone with an electromagnetic field.

Figure 2 is a sectional view of the lock in the shell. The lock comprises two members automatically interlocking one another when one member in form of a rod-shaped body is inserted in a cavity in the other member. The rod-shaped body is inserted in the cavity through a loosely arranged disk 18 of magnetizable material and engages balls 6 loosely arranged in the slightly conical cavity. A third part 8 in form of a cylindrical member of magnetizable material is inserted below the loosely arranged balls 6. A resilient member 10 with an upwardly directed driving force is inserted below the cylindrical member 8 of magnetizable material.

According to the invention the resilient member 10 is an annular plastic member with inward, helical connecting parts 10". The connecting parts 10" are connected to a centrally arranged, disk-shaped plastic member 10' with an opening in the middle, said plastic member pressing against the cylindrical member 8 in the cavity. The annular plastic member 10 is secured to a circumferential groove 11 in the bottom of the housing of the lock by way of squeezing. The housing comprises two halves interconnected by way of squeezing. The upper half 14 of the housing is made of brass whereas the lower half 16 is made of plastics.

The rod-shaped body 1 is released from the lock when the bottom is subjected to a very strong magnetic field with the result that the balls 6 are forced downwards. While the balls 6 are forced downwards, said balls 6 tend, however, to remain in the cone-shaped cavity. In order to solve this problem, an additional disk 18 of magnetizable material is loosely arranged above the balls 6 and is retained by an inward rim of the brass half 14 of the housing. The disk 18 presses the balls 6 downwards by means of a magnetic field. As a result the needle 1 can be easily retracted by means of a magnetic field device transferring the magnetic field to the upper disk 18. Such a magnetic field device is illustrated in Figure 4. It comprises a strong cylindrical permanent magnet inserted in an upwardly open, cylindrical, cup-shaped yoke of soft iron.

The cone angle in the cavity is approximately 6° and provides such a locking effect that the more the needle 1 is retracted the more the balls 6 are pressed

together around said needle 1. A locking effect cannot be achieved without the conical cavity. The iron cylinder 8 below the balls 6 causes a release of the balls 6 and presses the spring 10 downwards when subjected to a magnetic field. The iron cylinder 8 must be of a predetermined thickness in order not to saturate. In other words, the necessary magnetic field should be as strong as possible in order to avoid that unauthorized persons open the lock by means of for instance toy magnets. Such a situation can only be avoided when the cylinder 8 and the spring 10 are of a suitable size and force, respectively. As stated above, the housing of the lock is made of a non-magnetizable material. A body 16 of plastics is fastened to the outer side of the brass half 14 of the housing. The plastic body 16 is fastened to the brass half 14 by means of a snap device 11. The resilient body 10 is placed in the bottom of the plastic member 16, said resilient body simultaneously forming the bottom part. In the illustrated embodiment, the bottom part and the spring are formed in one piece. As a result the manufacture and assembling of the lock is considerably facilitated. Three helical arms 10" render it possible to provide a surface facing the cylinder 8, said surface always being perpendicular to the symmetrical axis. When the bottom part 10 is caused to press against the cylindrical member 8, the helical arms 10" turn slightly. At least three helical arms 10" must be provided in order to avoid a turning over of the bottom part. The bottom part 10 is preferably made of plastics (nylon).

The object of forming the lock as described above is to render it possible to use a needle without retaining grooves. Attempts at retracting and screwing out the needle 1 might result in a helical effect. Such attempts are, however, impossible due to an additional safety measure. Although the balls 6 do not touch one another, the number thereof, i.e. whether one or four balls are present, is of importance. When four balls are present and when said balls are identical and the conical cavity is round, all four balls press on the same cross section of the needle irrespective of how much said needle is retracted. Furthermore, an attempt at turning the needle results in said needle turning in the same groove all the time. In extreme cases with only one ball, it is difficult to center the needle in such a manner that it remains in the same position all the time. The needle will move a short distance. In order to avoid the situation where an unauthorized person can screw out the needle, i.e. pull in the needle so as to screw it out, it has been ensured that the balls press so hard against the needle 1 that they remain in said position all the time while the entire housing is turning. The lower member 4 of the antitheft device has been provided with an inward, circumferential bead 17 pressing against the brass half 14 of the lock. When the needle 1 is subjected to a pull, the lock moves towards the lower member. As

a result a friction is obtained between said lock and said lower member. The higher the friction is the more difficult it is for the lock to follow the turning if an unauthorized person tries to screw out the needle.

Claims

1. A lock, preferably for an antitheft device for marking articles for sale and comprising two members, which automatically interlock one another when one member is inserted in a cavity in the other member, the first member being a rod-shaped body (1) with a completely or partially pointed insertion end, whereby said rod-shaped body (1) is capable of engaging for instance balls (6) loosely arranged in the cavity of the second member, a third member (8) of magnetizable material being inserted below the loosely arranged balls (6), where a resilient member with an upwardly directed force is placed below said third member (8), characterised in that said resilient member (10) is an annular plastic member with inward connecting parts (10") connected to a centrally arranged disk-shaped plastic member (10") pressing against the third member (8) in the cavity.
2. A lock as claimed in claim 1, characterised in that the connecting parts (10") are helical.
3. A lock as claimed in claim 1 or 2, characterised in that the annular plastic member comprises three helical connecting parts (10").
4. A lock as claimed in claim 1, characterised in that the annular plastic member is secured to a circumferential groove in the bottom of the housing by way of squeezing.

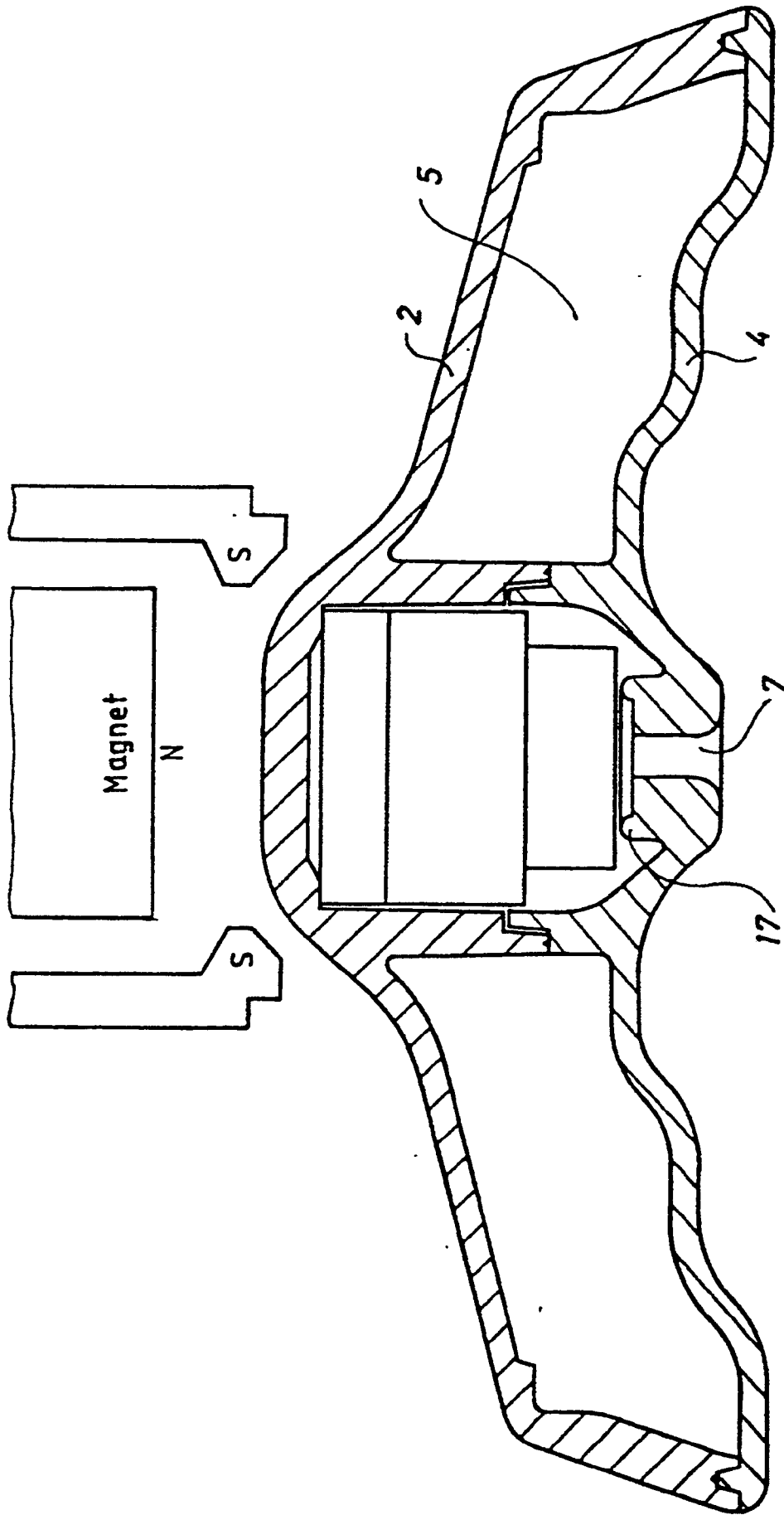

Fig.1

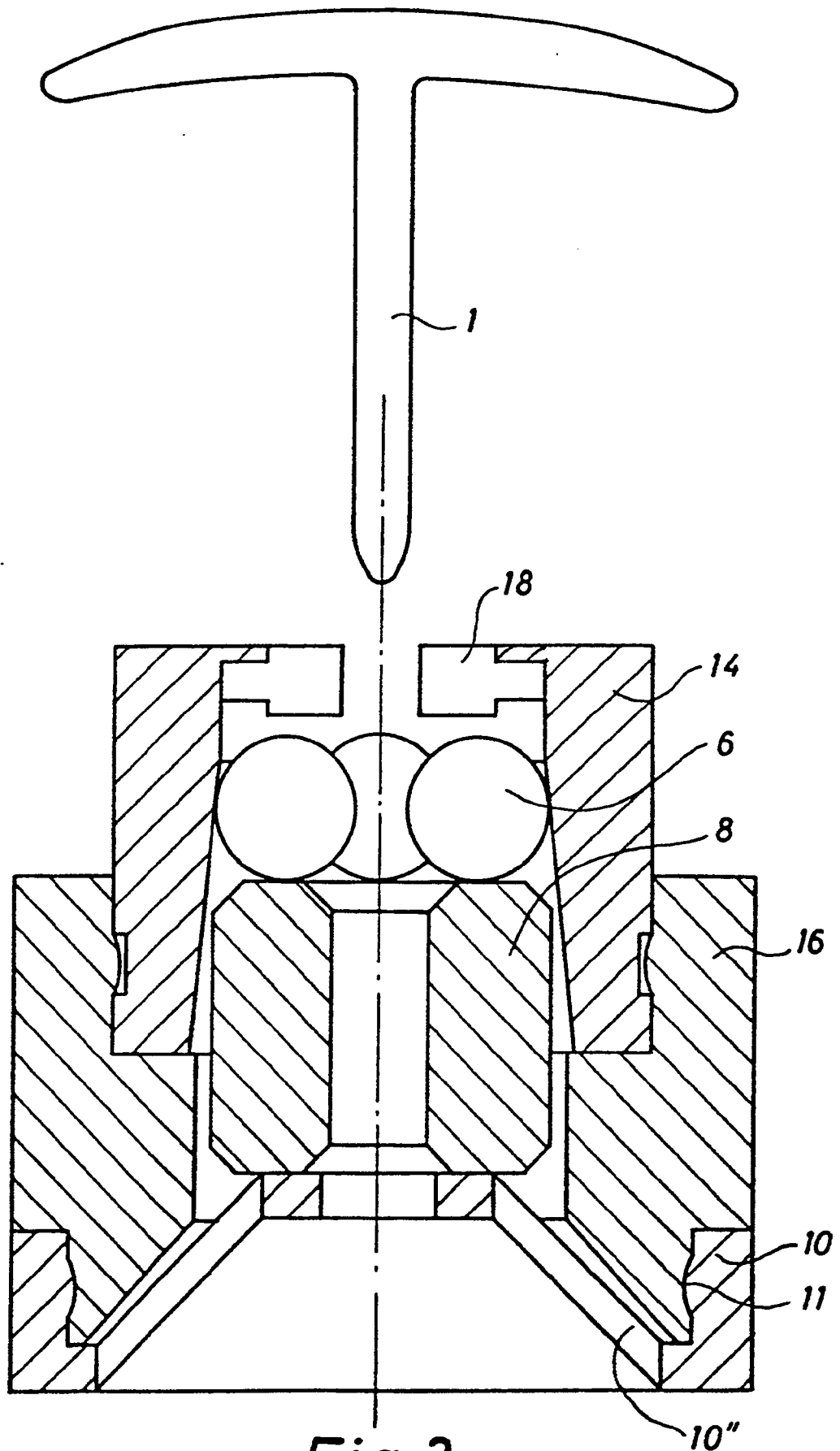

Fig. 2

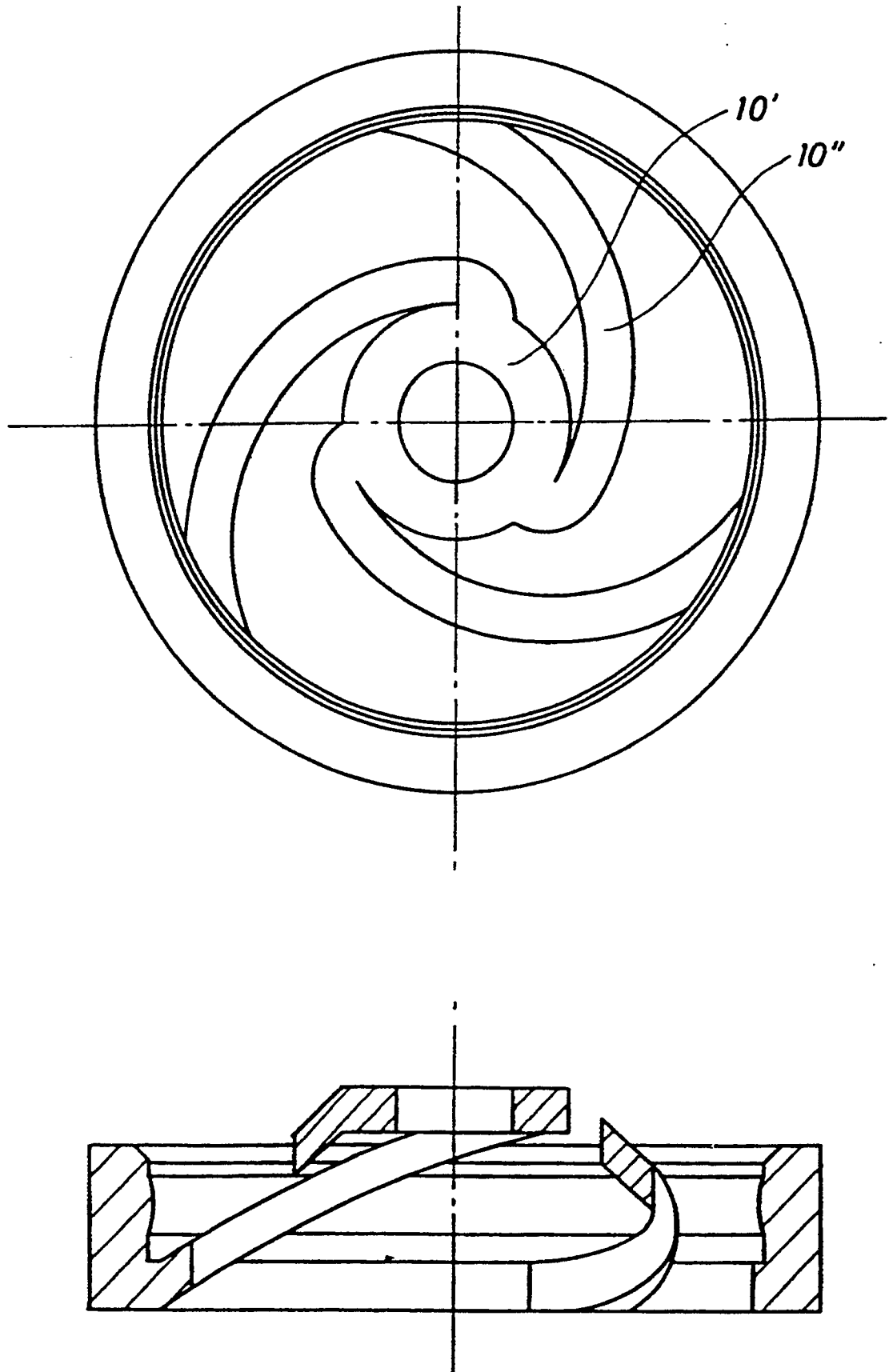

Fig.3

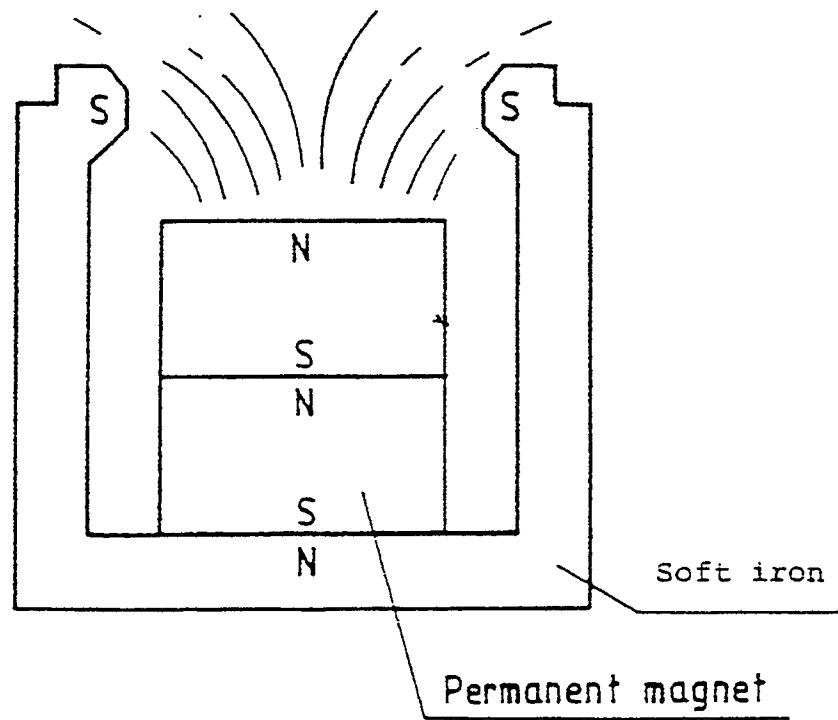

Fig.4



European Patent
Office

EUROPEAN SEARCH REPORT

Application Number

EP 91610038.1

DOCUMENTS CONSIDERED TO BE RELEVANT			
Category	Citation of document with indication, where appropriate, of relevant passages	Relevant to claim	CLASSIFICATION OF THE APPLICATION (Int. Cl.5)
A	<p><u>EP - B1 - 0 142 748</u> (ATONSON SECURITY DENMARK A/S "SYNGGAARDEN") * Fig. 1-5; claims 1-8 *</p>	1-4	E 05 B 17/10
D,A	<p><u>US - A - 3 858 280</u> (MARTENS) * Fig. 1-4; claims 1-2 *</p>	1	
D,A	<p><u>DE - A1 - 2 548 546</u> (I.D. ENGINEERING) * Fig. 1-2; claims 1-12 *</p>	1	
			TECHNICAL FIELDS SEARCHED (Int. Cl.5)
			E 05 B
The present search report has been drawn up for all claims			
Place of search VIENNA		Date of completion of the search 19-06-1991	Examiner CZASTKA
<p>CATEGORY OF CITED DOCUMENTS</p> <p>X : particularly relevant if taken alone Y : particularly relevant if combined with another document of the same category A : technological background O : non-written disclosure P : intermediate document</p> <p>T : theory or principle underlying the invention E : earlier patent document, but published on, or after the filing date D : document cited in the application I : document cited for other reasons</p> <p>----- & : member of the same patent family, corresponding document</p>			

EPO FORM 1503 03.81 (P0-01)