



Europäisches Patentamt
European Patent Office
Office européen des brevets



Publication number: **0 467 062 A2**

EUROPEAN PATENT APPLICATION

Application number: **91109304.5**

Int. Cl.⁵: **H01J 5/54**

Date of filing: **06.06.91**

Priority: **19.07.90 HU 454290**

Inventor: **Tamási, Ferenc**
Reviczky u. 34/c
H-1047 Budapest(HU)
Inventor: **Körmendi, Antal**
Izabella u. 85
H-1064 Budapest(HU)

Date of publication of application:
22.01.92 Bulletin 92/04

Designated Contracting States:
BE DE GB NL

Representative: **Patentanwälte Viering & Jentschura**
Steinsdorfstrasse 6 Postfach 22 14 43
W-8000 München 22(DE)

Applicant: **TUNGSRAM Részvénytársaság**
Váci ut. 77
H-1340 Budapest IV(HU)

Electric lamp with improved cap fixation.

Electric lamp (1) with improved cap fixation, comprising a light emitting member and current conductors connected thereto and a glass envelope (2) having a substantially cylindrical neck-shaped end portion (5) over which an end portion of a metal lamp cap (8) comprising a cylindrical and a screw-threaded portion is arranged. Along two opposite generatrices of the neck-shaped portion (5), two elongated recesses (7, 7'), one in each opposite position and extending over the neck portion (5) formed to accept the metal lamp cap (8) are provided and the neck-shaped portion (5) is also provided with an annular recess (6), over the neck-shaped portion (5) a metal lamp cap (8) is slid, the cylindrical portion of the metal lamp cap (8) is provided with a pair of elongated rib type elements (9, 9') engaging in the elongated recesses (7, 7') of the neck-shaped portion (5) and in the cylindrical portion of the metal lamp cap (8) engaging lugs (11, 11') are formed from the pair of strip-like portions (10, 10') determined by two pairs of adjacent slots (12) made in the cylindrical portion of the metal lamp cap (8) and the lugs (11, 11') fit the annular recess (6) in positions opposite to each other.

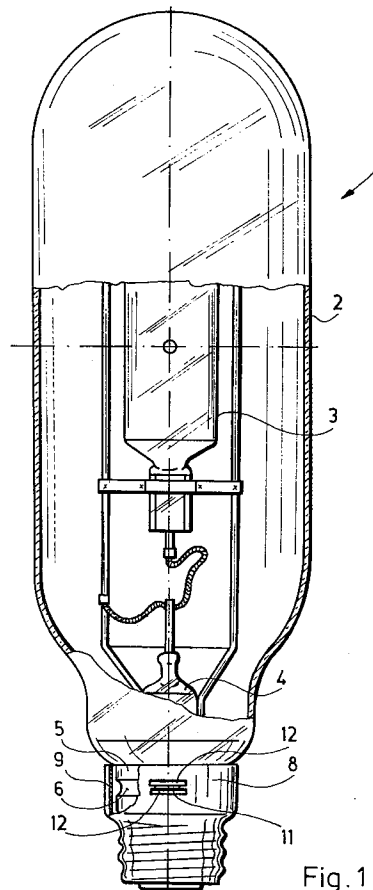

Fig. 1

EP 0 467 062 A2

The invention relates to an electric lamp, in particular to an improved solution for its capping.

The electric lamps according to the general practice comprise a light emitting member, current conductors connected to this light emitting member and a glass envelope, this latter having a neck-shaped end portion to accept a metal lamp cap. The metal lamp cap is fixed to the neck-shaped end portion.

In most electric lamps, the metal lamp cap is fixed to the neck-shaped end portion of the glass envelope by the means of a heat-resistant adhesive composition, i.e. a so-called capping cement.

Nevertheless, the use of a capping cement is linked with known disadvantages, e.g., since thermosetting adhesives are usually applied, thermal energy is to be introduced in order to achieve curing of the cement and also, as the process of curing itself requires a certain period of time to take place, this also should be considered as a disadvantage because of prolongating the technological processes.

Furthermore, during the operation of the electric lamp the thermoresistive cement can get aged, which ageing will render the cement unable to ensure a firm fixing any longer. This often has the consequence that the bond between the lamp envelope and metal lamp cap loosens and the glass envelope of the lamp can be separated from the cap remaining in the socket. This results in that an electric lamp being faultless except for its capping, can no longer be operated.

In order to eliminate these disadvantages, attempts have been made since long time to avoid the use of capping cement and to produce a firm mechanical joint between the metal lamp cap and the neck-shaped portion of the glass envelope.

These solutions, however, have not gained widespread application and at present the cemented bond is still the usual solution.

The widespread application of mechanical capping has been prevented by the fact that no construction has been found to ensure a mechanical joint with sufficient strength without adversely affecting the strength of the metal lamp cap and, as a consequence, shortening the lifetime of the electric lamp.

One of the above attempts is described in US-A-4 496 874. In the construction disclosed in the specification of this patent, the joint between the neck-shaped end portion of the glass envelope and the metal lamp cap is provided via an inserted resilient metal ring having slots and engaging parts.

The object of the present invention is to offer an electric lamp with improved metal lamp cap wherein no cement bond or metal ring is necessary.

The invention is based on the recognition that

the inserted metal ring can be eliminated if the neck-shaped end portion of the glass envelope has an appropriate shape and if a metal lamp cap having supporting and fixing portions made from its own material is fitted to the neck-shaped end portion. In this way the mechanical joint between the metal lamp cap and the neck-shaped end portion is simpler to be provided.

The requirement is that a mechanical joint between the neck-shaped end portion of the envelope and the metal lamp cap should be created which does not allow a "play", i.e. changes in the relative position of the cap to the glass envelope when the electric lamp is screwed in or removed from the socket. In order to meet this requirement, first two longitudinal elongated recesses are formed along two opposite generatrices of the substantially cylindrical neck-shaped portion of the glass envelope.

In these recesses two inwardly protruding longitudinal elongated rib type elements pressed out in the body of the metal lamp cap are engaged.

It was found that the elongated rib type elements are preferably formed to have an isosceles trapezoidal cross-section which is open from outside. If the elongated ribs have a V-shaped (isosceles triangle) cross-section, the metal lamp cap may weaken in some cases.

The above mentioned elongated rib type elements could, in principle, have a rectangular cross-section also, but this would make their forming process excessively difficult eliminating the possibility for mass-production. The elongated ribs having an open, isosceles trapezoid cross-section are suitable for mass-production, do not weaken the metal lamp cap and engage firmly in the elongated recesses formed in the neck-shaped portion of the glass envelope. Due to this, the elongated recesses and ribs engaging each other will ensure a firm joint between the glass envelope of the electric lamp and the metal lamp cap: the metal lamp cap will not turn around the neck-shaped portion of the electric lamp and the combination of these two components will behave itself as a firmly fixed unit when screwed in or out from the socket.

In addition, it should be noted that the use of rib type elements with rounded-edge cross-section may also cause problems as they would easily leave their recesses in the neck-shaped portion when the electric lamp is screwed in or out from the socket.

It is also necessary that a firm joint is provided preventing not only the displacements around the axis of the electric lamp, but those also that would occur along the axis of the lamp.

It is a further recognition that, in order to prevent longitudinal displacements, an annular recess over the entire circumference of the neck-shaped portion of the electric lamp is to be formed which

recess is preferably placed in the middle of the neck-shaped portion. In addition, in the cylindrical portion of the metal lamp cap, engaging lugs partly including the periphery of the cap and each of them determined by two slots are to be formed. The pairs of slots are preferably placed in opposite positions along the periphery and displaced by 90° relative to the elongate rib type elements. The engaging lugs are formed by pressing the strip-like portions determined by two adjacent slots onto the annular recess of the neck-shaped envelope portion. These lugs will prevent the longitudinal displacements.

In experiments it could be shown that the most preferable total length of the two strip-like portions determined by the adjacent slots is minimum one-fifth and maximum one-fourth of the circumference of the metal lamp cap.

Based on the above recognitions an electric lamp with novel construction of the cap was developed. The electric lamp comprises a light emitting member, current conductors connected thereto and a glass envelope, the glass envelope having a substantially cylindrical neck-shaped portion at its end and a metal lamp cap comprising a cylindrical and a screwthreaded portion connected by a conical intermediate portion which metal lamp cap is slid over said neck portion. According to the invention the new construction comprises elongated recesses extending over the glass envelope neck-shaped portion formed to receive the metal lamp cap are provided along two opposite generatrices of the neck-shaped portion, an annular recess is formed along the circumference of the neck-shaped portion and a metal lamp cap is slid over the neck-shaped portion, wherein the cylindrical portion of said metal lamp cap is provided with two elongated rib type elements, each engaging in the corresponding elongated recesses of the neck-shaped portion and form the cylindrical portion of said metal lamp cap, engaging lugs are formed out of the strip-like portions determined by two adjacent slots made in the cylindrical portion of the cap, said lugs are protruding inwardly and engaging in two opposite portions of the annular recess.

According to a preferred embodiment of the present invention, the cross-section of the elongated rib type elements form an open isosceles trapezoid.

In another preferred embodiment, the overall length of the strip-like portions is minimum one-fifth and maximum one-fourth of the circumference of the respective cylindrical part of the metal lamp cap.

In a further preferred embodiment, the strip-like portions are displaced by 90° relative to the elongated rib type elements of the cylindrical portion of the metal lamp cap.

It is also a preferred embodiment in which the annular recess in the neck-shaped portion is positioned along the centerline of said neck-shaped portion.

In an even further preferred embodiment, the strip-like portions are formed by making slots in the middle part of the cylindrical body portion of the metal lamp cap.

In the followings, one of the preferred embodiments of the present invention is described, merely to illustrate the invention and without any intention of limiting the scope of protection. In this description reference will be made to the attached drawings, wherein

- 15 FIG. 1 shows a high-wattage high-pressure gas discharge lamp, built-up according to the present invention and provided with an improved metal lamp cap partly in cross-section,
- 20 FIG. 2a a side elevational view of the neck portion of the proposed lamp in enlarged scale wherein the metal lamp cap fixed on the neck portions is viewed only in longitudinal cross-section,
- 25 Fig. 2b is the cross-section A-A of the neck portion and the metal lamp cap as shown in FIG. 2a,
- 30 Fig. 3a illustrates the metal lamp cap as improved by the present invention in a side elevational view,
- 35 Fig. 3b is another side elevational view of the improved metal lamp cap taken perpendicularly to that shown in FIG. 2a and
- 40 Fig. 3c illustrates the top view of the metal lamp cap arranged according to FIG. 3a.

In Fig. 1, a high-wattage high-pressure gas discharge lamp 1 containing a glass envelope 2, a discharge tube 3 and a metal lamp cap 8 for receiving the glass envelope 2 is shown, partly in section. The discharge tube 3 is supported by a stem 4 that also serves for the electric current supply of the discharge tube 3. The glass envelope 2 of the high-wattage high-pressure gas discharge lamp 1 has a substantially cylindrical neck-shaped end portion 5. In the mantle of the neck-shaped portion 5, along its two opposite generatrices two longitudinal elongated recesses 7, 7' are formed in longitudinal direction (see also Figs 2a and 2b). Into these elongated recesses 7, 7' that have e.g. R4 radius of curvature elongated rib type elements 9, 9' of the metal lamp cap 8 are engaged. The elongated rib type elements 9, 9' form respective depressions in the metal lamp cap 8, they have preferably an open, isosceles trapezoidal cross-section. In the example shown, the two elongated

rib type elements 9, 9' have equal heights and base widths of 3 to 4 mm and 2.5 mm, respectively. These dimensions indicate that the legs of the trapezoid make a relatively large angle with the base: the value of this angle is at least 135°. If the elongated rib type elements 9, 9' are formed to have these dimensions, the strength of the metal lamp cap 8 will not decrease, even in the case of a high-wattage version of the lamp 1 shown above.

The annular recess 6 is prepared along the centerline of the mantle of the substantially cylindrical neck-shaped portion 5, the length of the recess 6 is approx. 150 mm and this is identical with that of the circumference of the neck-shaped portion 5 of the high-wattage high-pressure gas discharge lamp 1. The annular recess 6 is formed to have an R2 radius of curvature. The strip-like portions formed by making two pairs of slots 12 in the metal lamp cap 8 are pressed into this annular recess 6 and the engaging lugs 10 are formed in this operation.

The procedure of capping is performed as follows:

Firstly, the neck-shaped portion 5 provided with the desired elongated recesses 7, 7' is formed. Then the elongated rib type elements 9, 9' that will fit in the recesses 7, 7' are formed along two opposite generatrices of the cylindrical portion of the metal lamp cap 8 (see Figs 3a, 3b). This is followed by making the strip-like portions 10 which is carried out by making two pairs of slots 12 opposite and parallel to each other and symmetrically positioned relative to the centerlines of the elongated rib type elements 9, 9' in the cylindrical portion of the metal lamp cap 8. The length of the slots 12 is 10 to 16 mm each and the strip-like portions 10 have a width of 1.5 to 2 mm each.

The metal lamp cap 8 formed in this way is then simply slid over the neck-shaped portion 5. Having this done, the strip-like portions 10 are pressed into the annular recess 6 using an appropriate tool and the engaging lugs 11 will be formed in this way. The engaging lugs 11 are indicated by dash lines in Fig. 2b. In order to assess the performance of capping, different high-wattage high-pressure gas discharge lamps 1 capped in accordance with the above procedure were tested. The capping withstands without damage a torque of 7 Nm and a tensile force of 100 N which enables the capping to be used with an acceptable safety level of operation.

In summary, the advantages offered by the electric lamps capped according to the invention are as follows:

- the use of capping cement containing toxic-materials can be eliminated;
- no separate cement baking equipment or capping machine is needed resulting in sub-

stantial energy savings (gas, compressed air, electric power);

- no additional materials or parts are needed;
- the processing time (for capping) can be shortened to one minute;
- the currently used metal caps can be applied without modification;
- the reject from capping process is minimized;
- in contrast to the cementing process, no harmful mechanical stresses will develop in the glass.

Although presented in relation to a high-wattage discharge lamp, the present invention can, of course be used in the case of any electric lamp, thus for incandescent lamps and other types of discharge lamps as well.

Claims

1. An electric lamp (1) with improved cap fixation, comprising a light emitting member and current conductors connected thereto and a glass envelope (2) having a substantially cylindrical neck-shaped end portion (5) over which an end portion of a metal lamp cap (8) comprising a cylindrical and a screwthreaded portion connected by a conical intermediate portion is arranged, characterized in that along two opposite generatrices of the neck-shaped portion (5) two elongated recesses (7, 7'), one in each opposite position and extending over the neck portion (5) formed to accept the metal lamp cap (8) are provided and the neck-shaped portion (5) is also provided with an annular recess (6), over the neck-shaped portion (5) a metal lamp cap (8) is slid, the cylindrical portion of the metal lamp cap (8) is provided with a pair of elongated rib type elements (9, 9') engaging in the elongated recesses (7, 7') of the neck-shaped portion (5) and in the cylindrical portion of the metal lamp cap (8), engaging lugs (11, 11') are formed from a pair of strip-like portions (10, 10') determined by two pairs of adjacent slots (12) made in the cylindrical portion of the metal lamp cap (8), and the lugs (11, 11') fit the annular recess (6) in positions opposite to each other.
2. Electric lamp according to claim 1, characterized in that the elongated rib type elements (9, 9') are made with open isosceles trapezoidal cross-section.
3. Electric lamp according to Claim 1 or 2, characterized in that the overall length of the strip-like portions (10, 10') is minimum one-fifth and maximum one-fourth of the circumference of the cylindrical portion of the metal lamp cap

(8).

4. Electric lamp according to claims 1, 2 or 3, characterized in that the strip-like portions (10, 10') are positioned rotated by 90° relative to the elongated rib type elements (9, 9'). 5
5. Electric lamp according to Claims 1, 2, 3 or 4, characterized in that the annular recess (6) is located in the middle portion of the neck-shaped portion (5). 10
6. Electric lamp according to Claims 1, 2, 3, 4 or 5, characterized in that the strip-like portions (10, 10') are located in the middle part of the cylindrical portion of the metal lamp cap (8). 15

20

25

30

35

40

45

50

55

5

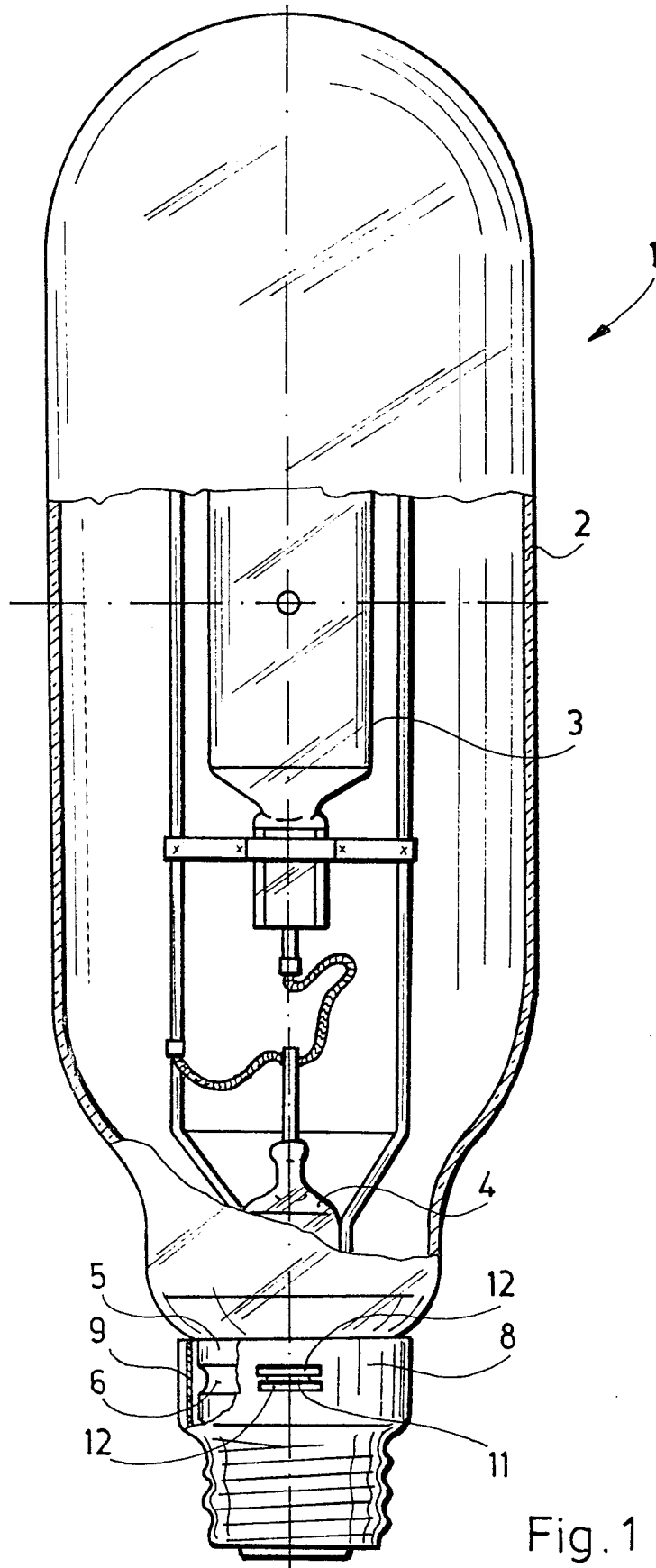
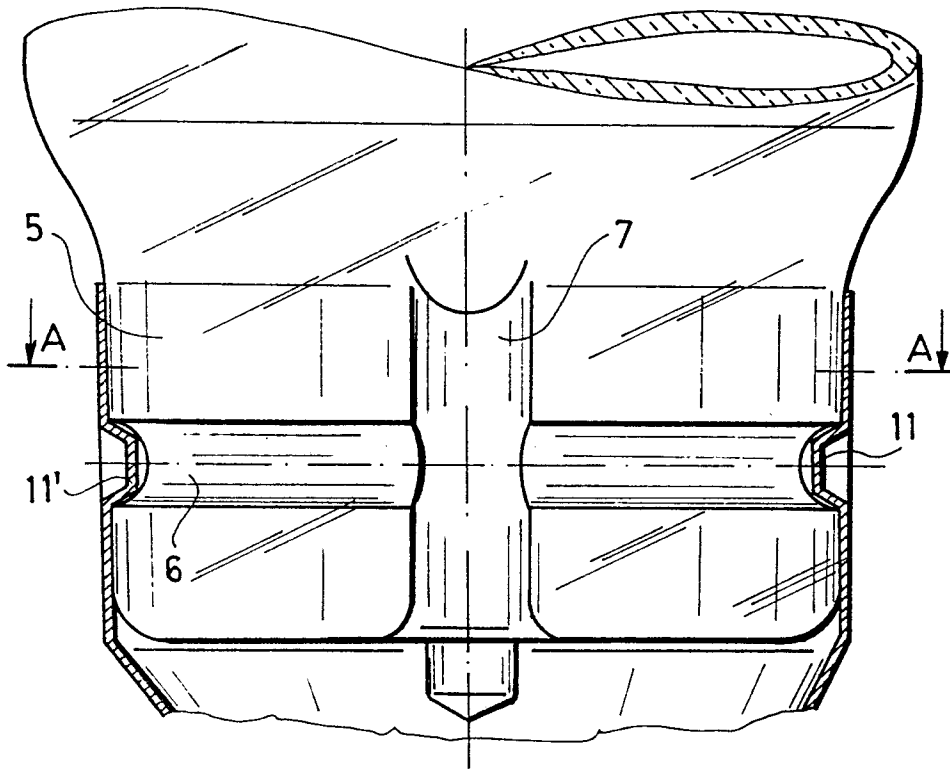

Fig. 1



g' Fig. 2a

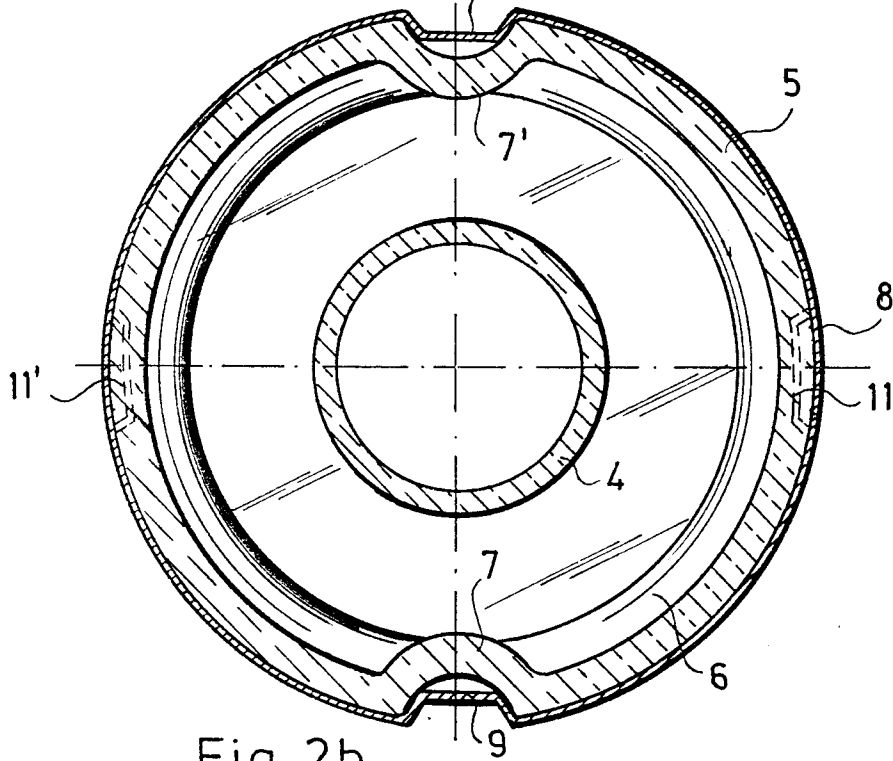

Fig. 2b

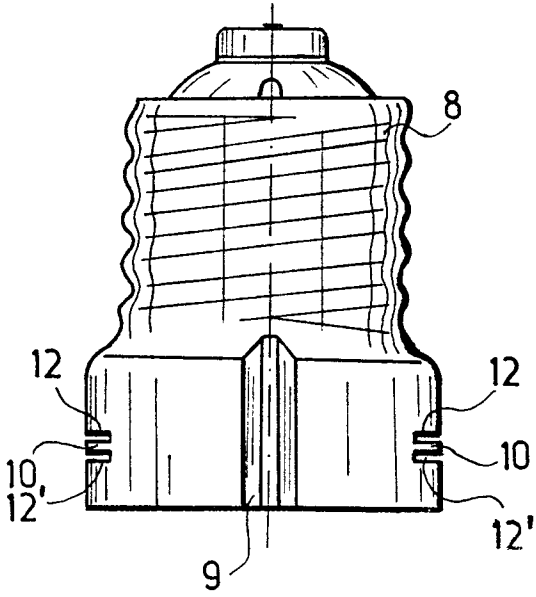

Fig.3a

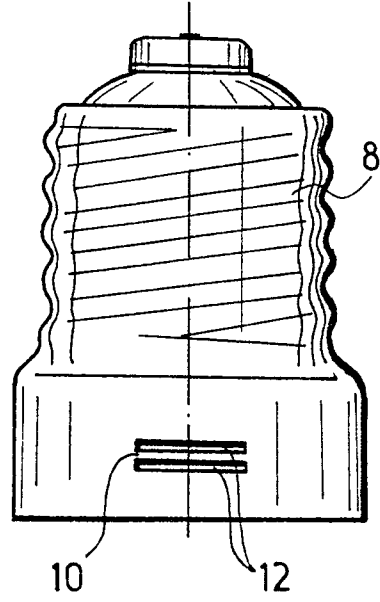

Fig.3b

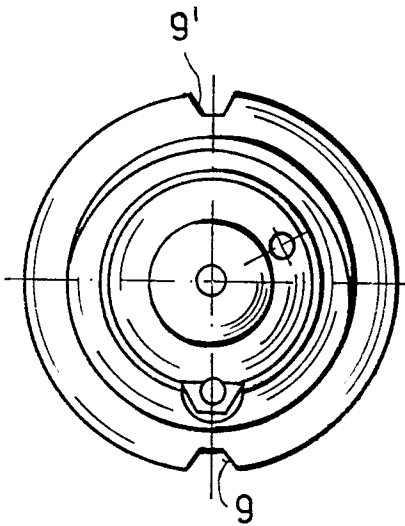

Fig.3c