



Europäisches Patentamt
European Patent Office
Office européen des brevets



Publication number: **0 469 676 B1**

12

EUROPEAN PATENT SPECIFICATION

- 49 Date of publication of patent specification: **15.02.95** 51 Int. Cl.⁸: **B65B 21/12**
21 Application number: **91201951.0**
22 Date of filing: **26.07.91**

54 **Apparatus for transferring bottles from a crate towards a conveyor.**

30 Priority: **27.07.90 NL 9001702**

43 Date of publication of application:
05.02.92 Bulletin 92/06

45 Publication of the grant of the patent:
15.02.95 Bulletin 95/07

84 Designated Contracting States:
BE DE ES FR GB IT LU NL

56 References cited:
DE-A- 2 445 273
NL-C- 103 605
US-A- 2 830 416
US-A- 4 206 941

73 Proprietor: **Smit, Gerardus**
Middelmonde 188
NL-3434 KT Nieuwegein (NL)

72 Inventor: **Smit, Gerardus**
Middelmonde 188
NL-3434 KT Nieuwegein (NL)

74 Representative: **Voncken, Bartholomeus Maria**
Christiaan et al
Octroibureau Los en Stigter B.V.
P.O. Box 20052
NL-1000 HB Amsterdam (NL)

EP 0 469 676 B1

Note: Within nine months from the publication of the mention of the grant of the European patent, any person may give notice to the European Patent Office of opposition to the European patent granted. Notice of opposition shall be filed in a written reasoned statement. It shall not be deemed to have been filed until the opposition fee has been paid (Art. 99(1) European patent convention).

Description

The invention relates to an apparatus for transferring bottles provided with an extending collar at their neck, such as PET-bottles or alike, from a crate having a partially open bottom towards a conveyor engaging the neck of each bottle. Such a conveyor may be of the type described in Dutch patent application 90.01589 of applicant, in which two distanced endless driven conveying elements, for example belts, receive between them the neck of each bottle.

Already apparatus are known which are able to lift bottles out of a crate. Thus lifting means are provided which are positioned above the crate and which are lowered, engage the neck of the bottle and lift the bottle out of the crate. It is a disadvantage of this known apparatus that the synchronization between the lifting means, the bottles in the crate and further conveying means requires special and complicated measures. Further, this known apparatus is not meant for bottles provided with an extending collar, nor can this known apparatus be used in connection with a conveyor of the previously mentioned type.

It is an object of the invention to provide an apparatus not offering these disadvantages.

In accordance with the invention an apparatus is provided for transferring bottles provided with an extending collar at their neck, such as PET-bottles or alike, from a crate having a partially open bottom towards a conveyor engaging the neck of each bottle, the apparatus comprising a conveying device for horizontally moving the crate and lifting means which at least temporarily move onwards synchronously with the crate, said lifting means being movable upward and downward relative to the crate for engaging the lower side of the bottles and thus lifting these in such a way that their neck may be gripped by the conveyor.

A supplied crate filled with bottles is positioned on the conveying device which horizontally propels the crate. During, or previously to, this propulsion of the crates the lifting means lift the bottles such that the neck thereof projects beyond the upper edge of the crate. In this position the necks may be engaged by the conveyor positioned above the conveying device for further removing the bottles.

Basically the apparatus according to the invention has fulfilled its function when the bottles are lifted relative to the crate in such a way that their necks may be engaged by the conveyor. Entirely removing the bottles from the crate thereafter is carried out by the conveyor. In this respect it is essential that the distance between the conveyor and the crate increases in the propulsion direction of the crates. For the realization thereof there are several possibilities. It is possible that the crates,

after engagement of the bottles by the conveyor, keep on moving horizontally whereas the conveyor follows an upwardly inclined track, such that the bottles are lifted out of the crate. However, it is also possible that the conveyor follows a horizontal track whereas the crates, after engagement of the bottles by the conveyor, follow an downwardly inclined track. Now also the bottles are lifted out of the crate. A combination of both previously mentioned possibilities also leads to a good result.

Further, it is noted that the conveyor engaging the neck of the bottles also could comprise a stationary guiding. Generally, in such a case the increasing distance between the conveyor and the crate will be realized by moving the crates inclined downwardly.

In a preferred embodiment of the apparatus according to the invention the conveying device comprises at least one slide for housing at least one crate, in which slide the lifting means are mounted movably upward and downward. The supply of the crates to the slides occurs in a way not described further, for an expert however easy to realize, such that each slide houses at least one crate. The lifting means, which are part of the slides, thus are automatically positioned correctly relative to the bottles present in the crate, such that the lifting means function in a reliable way.

Further, it is advantageous if the conveying device comprises an endless belt carrying the slides. In such an embodiment the apparatus may operate continuously. The supplied crates are positioned at one side of the conveying device and are removed at the other side. In the intermediate section the removal of the bottles from the crates occurs.

It is advantageous if the lifting means are provided with follower rolls cooperating with a stationary curved track. It is possible, for example, that each lifting means has its own follower roll, so that through an appropriate choice of the shape of the curved track care can be taken that each bottle is presented correctly to the neck engaging conveyor. Lifting a bottle then occurs always at the same position of the conveying device.

Further, an embodiment of the apparatus may be realized, in which the lifting means are provided with such a drive mechanism, that they carry out at least a vertical motion for lifting the bottles and successively a horizontal motion for propelling the crates. So the lifting means now constitute the conveying device for the crate too. Then constructively an embodiment is advantageous, in which the drive mechanism comprises two similar endless chains or alike, which, positioned above each other, each occupy a vertical plane and describe a mainly rectangular track, wherein the corresponding sections of the chains are connected by a

connection member carrying the lifting means.

Further, it is constructively advantageous if the lifting means of a crate are interconnected and are movable upward and downward together. In contrast to the previous embodiment now all bottles are commonly moved upward and downward. The lifting means of one single crate are now operated by one single follower roll, such that the motion of the lifting means occurs simultaneously.

A simple constructive solution is provided by lifting means which comprise pins movable upward and downward through the bottom of the crate. The pins are provided in a pattern which corresponds with the pattern of the bottles in the crate, so that always one single pin engages a single bottle.

If at least three pins are provided for each bottle to be lifted the bottle maintains a stable position while being lifted.

According to an alternative embodiment of the apparatus according to the invention the lifting means comprise radial projections of a vertical wheel positioned below the conveying device, wherein a part of the circumference of the wheel is substantially tangent with the track of the crates propelled by the conveying device and of which wheel the circumferential velocity substantially corresponds with the propulsion velocity of the conveying device. Because the radial projections of the vertical wheel follow a circular track they move upward and downward relative to the crate. So these radial projections may function as lifting means and may lift the bottles relative to the crate.

Hereafter the invention will be elucidated referring to the drawing in which three embodiments of the apparatus according to the invention are represented.

Fig. 1 shows, schematically and in a side elevational view, an embodiment of the apparatus according to the invention;

Fig. 2 shows a detail of the apparatus shown in Fig. 1 on a larger scale;

Fig. 3 shows schematically the principle of an alternative embodiment of the apparatus according to the invention, and

Fig. 4 shows schematically the principle of a third embodiment of the apparatus according to the invention.

As can be seen in Fig. 1 the apparatus comprises in the shown embodiment a conveying device 1 comprising slides 3 which are interconnected by an endless chain 2 or alike and which are supported by a guiding 4. In a way not shown further the chain 2 is driven in such a way that the slides 3 follow an endless track in the direction indicated with arrows.

Of course, several different embodiments are conceivable for moving around such slides. An endless slide carrying belt offers an alternative to

the shown embodiment. Further, it is conceivable that two parallel endless round-going chains are used which are each supported in an appropriate way by chain wheels and between which the slides are suspended. In such an embodiment a guiding 4 is not required.

At the upper side the slides 3 are provided with a recess 5 for housing a crate 6 in which the bottles 7 are positioned. Instead of recess 5 it is also possible that the slides 3 comprise at the upper side carriers for in a controlled way receiving a crate 6.

The crates 6 filled with bottles 7 are supplied to the apparatus through a supply device 8 only indicated schematically. As such a supply device several devices known per se may be used, such as a chute or a conveying belt. Appropriate means may be provided then for at the correct moment supplying a crate 6 to a passing slide 3.

The bottles 7 present in the crates 6 are provided with an extending collar 9 at their neck (see Fig. 2) onto which a conveyor 10 positioned above the apparatus should engage. For example such bottles may comprise the so-called PET-bottles.

The conveyor 10 positioned above the apparatus preferably comprises a conveyor of the type as described in Dutch patent application 90.01589, of which the conveying elements comprise belts or alike engaging the neck of the bottles to be conveyed.

Each slide 3 comprises a lifting device 11 to be elucidated further referring to Fig. 2, which in co-operation with a stationary curved track 12 realizes the partially lifting of the bottles 7 out of the crate 6. The bottles 7 lifted thus are presented to the conveyor 10 that then entirely removes the bottles from the crates 6 and discharges them.

The empty crates 6 are, in a way not shown further, presented to a discharge device 13 indicated only schematically that may mainly correspond with the supply device 8.

The operation of the apparatus shown in Fig. 1 is elucidated further with reference to Fig. 2. The lifting device 11 of the slides 3 comprises a number of interconnected pins 14 which are housed movable upward and downward in recesses 15 shaped in the slides 3. The pins 14 carry a follower roll 16 following the curved track 12. The pins 14 of the right-hand slide 3 in Fig. 2 are in their lowermost position as a result of the co-operation between the follower roll 16 and the curved track 12. In this position the uppermost ends of the pins 14 do not engage the bottles 7 present in the crate 6.

When moving further the crate 6 to the left reaches a position according to the central crate in Fig. 2.

The follower roll 16 has been moved upward by the curved track 12 such that the pins 14 have reached

their uppermost position. In this position they engage the bottom of the bottles 7 and have lifted these bottles 7 relative to the crate 6. The distance over which the bottles 7 are lifted is such that a neck provided with a collar 9 extends beyond the upper edge of the crate 6. So the conveyor 10 may engage this collar 9.

While lifting the bottles 7 relative to the crate 6 the crate functions as a guiding for the bottles 7 prohibiting the bottles from tumbling down.

Next the slide 3 with crate 6 reaches the position according to the left-handed slide 3 in Fig. 2. The follower roll 16 has left the curved track 12 and the pins 14 have reached their lowermost position again. The bottles 7 have been removed almost entirely from the crate 6 as a result of an upwardly inclined direction of the conveyor 10. It is noted that generally the propulsion velocity of the conveyor 10 equals the propulsion velocity of the conveying device 1, so that no relative velocity occurs between the bottles 7 conveyed by the conveyor 10 and the crates 6 which could result in jamming.

Many alternative embodiments of the apparatus according to the invention are conceivable. Only as an example an embodiment is mentioned, in which the lifting device for lifting the bottles 7 is not movable upward and downward through a curved track 12 but through separately activatable drive means, such as cylinder-piston assemblies. Further, the shape of the curved track 12 may be varied widely too. Although the curved track extends in Fig. 1 and Fig. 2 only over a small part of the entire apparatus it is possible too that the curved track extends all the way around, such that the follower rolls 16 are always received in this curved track.

For the sake of completeness the following is noted. In the crates 6 to be emptied the bottles are positioned in a special pattern beside and behind each other. The pins 14 of the lifting device 11 may be provided in correspondence with this pattern. However, this means too that a number of adjacently positioned conveyors 10 for discharging the bottles 7 are applied. The basic principle of the apparatus according to the invention does not change however.

An alternative embodiment of the apparatus according to the invention is shown in Fig. 3. One can see a part of an endless conveyor 16 with carriers 17 for crates 6. Below the conveyor 16 a vertical wheel 18 is positioned having radial projections 19. Part of the circumference of the wheel 18 is substantially tangent to the track of the crates 6 propelled by the conveyor 16. The circumferential velocity of the wheel 18 substantially corresponds with the propulsion velocity of the conveyor 16. As a result of the cooperation between the radial pro-

jections 19 and the bottles 7 present in the crate 6 these bottles 7 are lifted in the way illustrated. So these bottles may be received successively by the conveyor 10 and may be discharged.

5 Of course in such an embodiment the shape of the crates 6, in which the bottles 7 are present, should enable the movement therein of the radial projections 19.

10 In Fig. 4 a different alternative embodiment of the apparatus according to the invention is illustrated. In this embodiment two endless chains 20 and 21 are provided which are each positioned in a vertical plane and follow a substantially rectangular track and which extend around guiding rolls 22. Corresponding sections of the chains 20 and 21 are interconnected by a connection member 24 carrying the lifting means 23. If now the chains 20 and 21 are driven synchronously the connection member 24 will follow a nearly rectangular track, while maintaining its illustrated upright position. In the position illustrated in full lines the connection member 24 is in a track section where it moves vertically upwards (as a result of the direction of movement of the chains 20 and 21 indicated by arrows). Now with the lifting means 23 it may engage the bottles 7 in a crate 6 which is present on an appropriate support 25. So the bottles 7 are lifted. Next the connection member 24 will follow the horizontal track sections of the chains 20 and 21, as indicated in the uppermost dotted position of the connection member 24. Now the lifting 23 have not only lifted the bottles 7, but also propel the crate 6 along the support 25.

35 At the opposite vertical track section of the chains 20 and 21 the connection member 24 is moved downwardly vertically and will be moved back through the lowermost horizontal track sections (as indicated by the dotted represented position). Now the crate is freed.

40 Previously it has been described how, using the apparatus according to the invention, bottles can be removed from crates 6 and can be supplied to a conveyor 10. However, basically it is conceivable too that the apparatus according to the invention is used for transferring bottles 7 from a conveyor 10 into the crates 6. In this respect mainly a reversal of the direction of motion of the several parts of the apparatus would be sufficient. In such a case only care should be taken to realize a proper synchronization between the supply of the bottles 7 by the conveyor 10 and the supply of the crates 6 by the slides 3. The required devices belong to the domain of control engineering and do not fall within the scope of the invention.

55 The invention is not limited to the embodiments described before which can be varied within the scope of the invention as defined in the appended claims.

Claims

1. Apparatus for transferring bottles (7) provided with an extending collar at their neck, such as PET-bottles or alike, from a crate (6) having a partially open bottom towards a conveyor (10) engaging the neck of each bottle (7), the apparatus comprising a conveying device (1) for horizontally moving the crate (6) and lifting means (11) which at least temporarily move on wards synchronously with the crate (6), said lifting means (11) being movable upward and downward relative to the crate (6) for engaging the lower side of the bottles (7) and thus lifting these in such a way that their neck may be gripped by the conveyor (10). 5 10 15
2. Apparatus according to claim 1, wherein the conveying device (1) comprises at least one slide (3) for housing at least one crate (6), in which slide (3) the lifting means (11) are mounted movably upward and downward. 20
3. Apparatus according to claim 2, wherein the conveying device (1) comprises an endless belt (2) carrying the slides (3). 25
4. Apparatus according to claim 2 or 3, wherein the lifting means (11) are provided with follower rolls (16) cooperating with a stationary curved track (12). 30
5. Apparatus according to claim 1, wherein the lifting means (11) are provided with such a drive mechanism, that they carry out at least a vertical motion for lifting the bottles (7) and successively a horizontal motion for propelling the crates (6). 35
6. Apparatus according to claim 5, wherein the drive mechanism comprises two similar endless chains (20, 21) or alike, which, positioned above each other, each occupy a vertical plane and describe a mainly rectangular track, wherein the corresponding sections of the chains (20, 21) are connected by a connection member (24) carrying the lifting means (23). 40 45
7. Apparatus according to one of the claims 1-6, wherein all lifting means (11: 20, 21) of a crate are interconnected and are movable upward and downward together. 50
8. Apparatus according to one of the claims 1-7, wherein the lifting means (11: 20, 21) comprise pins movable upward through the bottom of the crate (6). 55
9. Apparatus according to claim 8, wherein at least three pins are provided for each bottle to be lifted.
10. Apparatus according to claim 1, wherein the lifting means comprise radial projections (19) of a vertical wheel (18) positioned below the conveying device (1), wherein a part of the circumference of the wheel is substantially tangent with the track of the crates (6) propelled by the conveying device (1) and of which wheel (18) the circumferential velocity substantially corresponds with the propulsion velocity of the conveying device (1).

Patentansprüche

1. Vorrichtung zum Transportieren von Flaschen (7), die am Hals mit einem hervorstehenden Flansch versehen sind, wie beispielsweise PET-Flaschen oder ähnliche Flaschen, aus einer Kiste (6), die einen teilweise geöffneten Boden aufweist, zu einer Fördereinrichtung (10) die mit dem Hals der Flaschen (7) in Eingriff gelangt, mit einer die Kiste (6) horizontal bewegenden Förderanlage (1) und mit einer sich zumindest zeitweise synchron mit der Kiste vorwärts bewegenden Anhebevorrichtung (11), wobei die Anhebevorrichtung (11) nach oben und nach unten relativ zur Kiste (6) bewegbar ist, um mit der unteren Seite der Flaschen (7) in Eingriff zu gelangen und um die Flaschen (7) derart anzuheben, daß der Hals der Flaschen (7) von der Fördereinrichtung (10) gegriffen werden kann.
2. Vorrichtung nach Anspruch 1, wobei die Förderanlage (1) für die Aufnahme mindestens einer Kiste (6) mindestens einen Schlitten (3) aufweist, in dem die Anhebevorrichtung (11) nach oben und nach unten bewegbar angeordnet ist.
3. Vorrichtung nach Anspruch 2, wobei die Förderanlage (1) ein die Schlitten (3) tragendes endloses Band (2) aufweist.
4. Vorrichtung nach Anspruch 2 oder 3, wobei die Anhebevorrichtung (11) mit einem Laufrad versehen ist, das mit einer stationären, gebogenen Schiene (12) zusammenwirkt.
5. Vorrichtung nach Anspruch 1, wobei die Anhebevorrichtung (11) derart mit einer Antriebsvorrichtung versehen ist, daß die Anhebevorrichtung (11) mindestens eine vertikale Bewegung für ein Anheben der Flaschen (7) und nachfolgend eine horizontale Bewegung für ein Antrei-

ben der Kisten (6) ausführt.

6. Vorrichtung nach Anspruch 5, wobei der Antriebsmechanismus zwei einander entsprechende endlose Ketten (20, 21) oder ähnliche Elemente aufweist, die übereinander angeordnet sind und jeweils in einer Ebene liegen und ein im wesentlichen rechteckiges Laufband darstellen, wobei sich entsprechende Abschnitte der Ketten (20, 21) mit einem ein Anhebeelement (23) tragenden Verbindungselement (24) verbunden sind. 5
7. Vorrichtung nach einem der Ansprüche 1 bis 6, wobei alle einer Kiste (6) zugeordneten Anhebeelemente (11; 20, 21) miteinander verbunden und zusammen nach oben und nach unten bewegbar sind. 10
8. Vorrichtung nach einem der Ansprüche 1 bis 7, wobei die Anhebeelemente (11; 20, 21) durch den Boden der Kiste (6) nach oben bewegbare Stifte aufweisen. 15
9. Vorrichtung nach Anspruch 8, wobei mindestens drei Stifte für jede anzuhebende Flasche vorgesehen sind. 20
10. Vorrichtung nach Anspruch 1, wobei die Anhebevorrichtung radial verlaufende Verlängerungen (19) eines vertikal angeordneten Rades (18) aufweist, das unterhalb der Förderanlage (1) angeordnet ist, wobei ein Teil des Umfanges des Rades im wesentlichen tangential mit der von der Förderanlage angetriebenen Laufbahn der Kisten verläuft und wobei die Umfangsgeschwindigkeit des Rades im wesentlichen der Antriebsgeschwindigkeit der Förderanlage (1) entspricht. 25
30
35
40

Revendications

1. Dispositif pour transférer des bouteilles (7) munies d'une collerette en saillie sur leur col, telles que des bouteilles PET ou similaire, à partir d'une caisse (6), comportant un fond partiellement ouvert, vers un convoyeur (10) venant en prise sur le col de chaque bouteille (7), le dispositif comprenant un système de convoyage (1) pour déplacer horizontalement la caisse (6) et des moyens de soulèvement (11) qui se déplacent au moins temporairement en synchronisme avec la caisse (6) lesdits moyens de soulèvement (11) étant mobiles vers le haut et vers le bas, par rapport à la caisse (6) pour venir en prise sur le côté inférieur des bouteilles (7) en les soulevant ainsi de manière que leur col puisse être saisi 45
50
55

par le convoyeur (10).

2. Dispositif selon la revendication 1 dans lequel le système de convoyage (1) comprend au moins un chariot (3) pour loger au moins une caisse (6), chariot (3) dans lequel les moyens de soulèvement (11) sont montés mobiles vers le haut et vers le bas.
3. Dispositif selon la revendication 2 dans lequel le système de convoyage (1) comprend une bande sans fin (2) supportant les chariots (3).
4. Dispositif selon la revendication 2 ou 3 dans lequel les moyens de soulèvement (11) sont munis de rouleaux palpeurs (16) coopérant avec une voie fixe incurvée (12).
5. Dispositif selon la revendication 1 dans lequel les moyens de soulèvement (11) sont munis d'un mécanisme d'entraînement tel qu'ils puissent effectuer au moins un mouvement vertical pour soulever les bouteilles (7) et, successivement un mouvement horizontal pour déplacer les caisses (6).
6. Dispositif selon la revendication 5 dans lequel ledit mécanisme d'entraînement comprend deux chaînes sans fin similaires (20, 21), ou similaire, qui, positionnées l'une au-dessus de l'autre, occupent chacune un plan vertical et décrivent un tracé essentiellement rectangulaire, les sections correspondantes des chaînes (20, 21) étant connectées par un élément de liaison (24) supportant les moyens de soulèvement (23).
7. Dispositif selon l'une des revendications 1 à 6 dans lequel tous les moyens de soulèvement (11;20;21) d'une caisse sont interconnectés et sont mobiles ensemble vers le haut et vers le bas.
8. Dispositif selon l'une quelconque des revendications 1 à 7, dans lequel les moyens de soulèvement (11 ; 20 ; 21) comportent des broches mobiles vers le haut au travers du fond de la caisse (6).
9. Dispositif selon la revendication 8 dans lequel au moins trois broches sont prévues pour chaque bouteille devant être soulevée.
10. Dispositif selon la revendication 1, dans lequel les moyens de soulèvement comprennent des saillies radiales (19) d'une roue verticale (18) positionnée en dessous d'un dispositif de convoyage (1), dans lequel une partie de la

circonférence de la roue est sensiblement tangente à la voie des caisses (6) déplacées par le dispositif de convoyage (1), la vitesse circonférentielle de ladite roue (18) correspond sensiblement à la vitesse de déplacement du dispositif de convoyage (1). 5

10

15

20

25

30

35

40

45

50

55

7

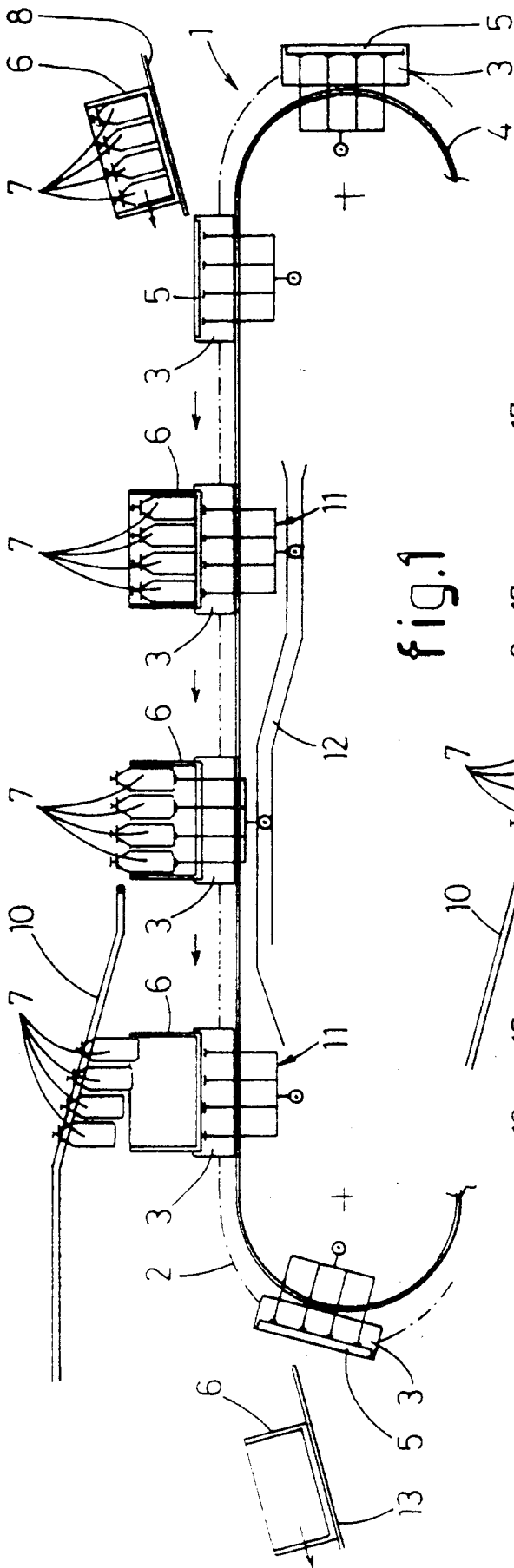

fig.1

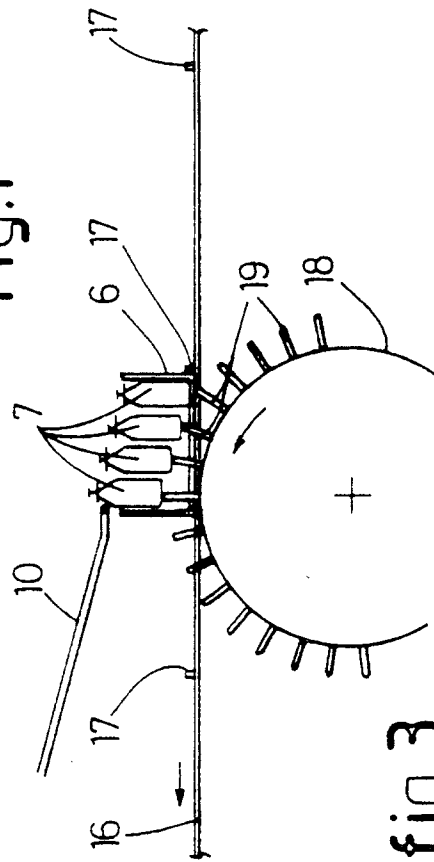

fig.3

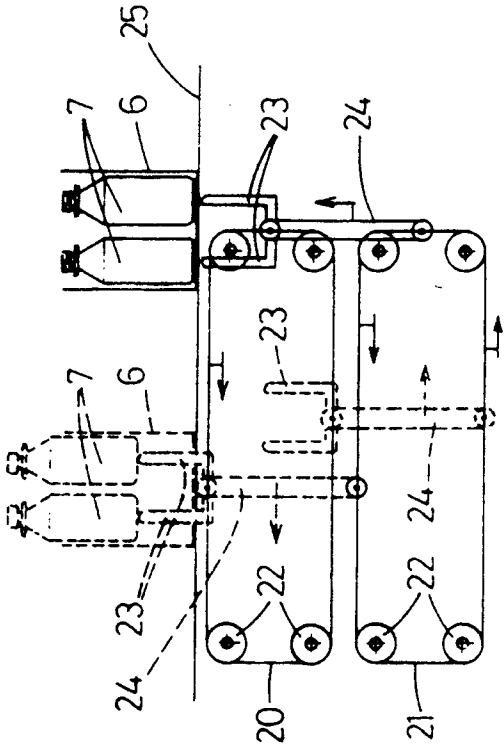

fig.4

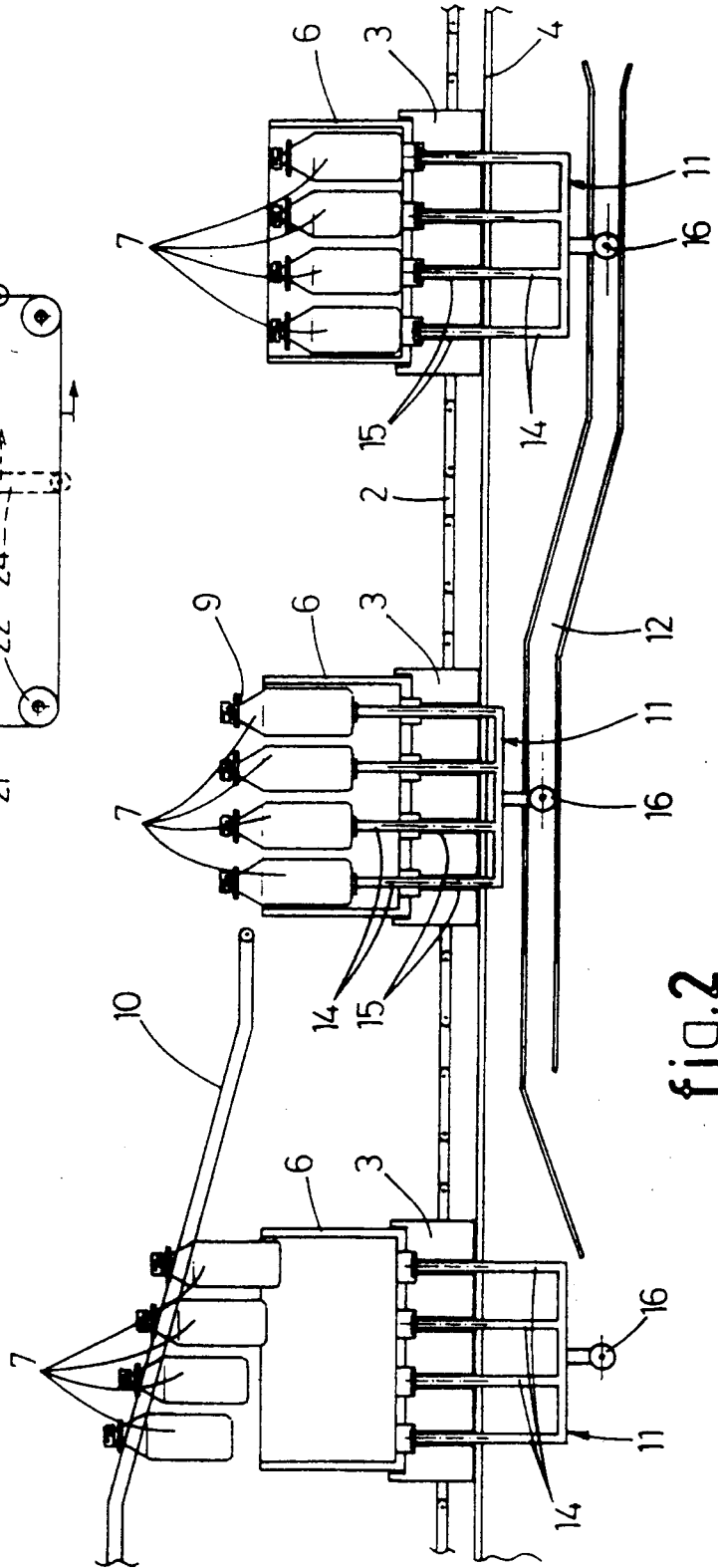

fig.2