



12

EUROPEAN PATENT SPECIFICATION

45 Date of publication of patent specification :
30.08.95 Bulletin 95/35

51 Int. Cl.⁶ : **H01H 33/91**

21 Application number : **91118583.3**

22 Date of filing : **31.10.91**

54 **High-voltage circuit breaker.**

30 Priority : **02.11.90 SE 9003509**

73 Proprietor : **ASEA BROWN BOVERI AB**
S-721 83 Västerås (SE)

43 Date of publication of application :
06.05.92 Bulletin 92/19

72 Inventor : **Bendiksen, Odd**
Gragasvägen 18 C
S-771 52 Ludvika (SE)
Inventor : **Worzyk, Thomas**
Gränsgatan 7
S-771 41 Ludvika (SE)

45 Publication of the grant of the patent :
30.08.95 Bulletin 95/35

84 Designated Contracting States :
CH DE ES FR GB IT LI

74 Representative : **Boecker, Joachim, Dr.-Ing.**
Adelonstrasse 58
D-65929 Frankfurt am Main (DE)

56 References cited :
EP-A- 0 194 489
CH-A- 527 493
CH-A- 555 589
FR-A- 2 297 487
US-A- 3 674 956

EP 0 483 840 B1

Note : Within nine months from the publication of the mention of the grant of the European patent, any person may give notice to the European Patent Office of opposition to the European patent granted. Notice of opposition shall be filed in a written reasoned statement. It shall not be deemed to have been filed until the opposition fee has been paid (Art. 99(1) European patent convention).

Description

The invention relates to a high-voltage circuit breaker according to the precharacterising part of claim 1. The circuit breaker may be designed in accordance with the self-blast and/or puffer principle.

5 The invention is primarily intended for circuit breakers with rated operating voltages in excess of 100 kV.

Circuit breakers of the above-mentioned kind are previously known, for example from US-A-4 658 108. In such a so-called puffer-type self-blasting circuit breaker, the reservoir for gas intended for arc extinction consists of two parts, namely a pressure storage chamber, in the following also called the pressure storage volume, and a compression chamber, in the following also called the puffer or auxiliary puffer volume. The two volumes
10 are separated by a nonreturn valve which is closed when the pressure in the pressure storage volume is higher than in the puffer volume.

In a conventional high-voltage circuit breaker according to the self-blasting principle for rated voltages of up to 145 kV, among other things the blast nozzle, the pressure storage chamber and the auxiliary puffer cylinder are mounted on the movable part of the contact system and must thus be accelerated by the operating
15 device. When changing to a higher rated voltage, for example 245 kV, the arcing contacts must be pulled apart at a higher rate to ensure the dielectric strength. Moving also the blast nozzle, the pressure storage chamber and the auxiliary puffer cylinder at the same speed requires very considerable operating energy.

From DE-A-2 753 375 and DE-C-2 946 929, it is known, in a puffer-type circuit breaker, to connect the movable parts of the breaker to the operating device with the aid of rotatably journalled lever arms or a rack and pinion mechanism in such a way that the movable arcing contact during the opening operation moves at a greater speed than the movable part of the puffer device (which movable part may consist of the piston or cylinder of the device) and the blast nozzle built together with that part. This results in a considerable reduction of the need for operating energy. In the prior art designs there is always a fixed ratio, for example 2:1, between the speeds of the movable contact and of the other parts.

25 The invention aims at developing a high-voltage circuit breaker of the above-mentioned kind, which also when being used at high voltages need less operating energy and makes possible better dielectric coordination than comparable known designs.

To achieve this aim the invention suggests a high-voltage circuit breaker according to the introductory part of claim 1, which is characterized by the features of the characterizing part of claim 1.

30 Further developments of the invention are characterized by the features of the additional claims.

In a particularly suitable embodiment of the invention, the movable contacts are connected to the operating device via a special link mechanism, which will be described in greater detail below. With this embodiment, a speed ratio between the two contact systems may be achieved which alters during the course of the opening movement, whereby great advantages may be obtained. This embodiment permits the movable operating current contact and the movable arcing contact to be accelerated at different times during the opening operation,
35 whereby the maximum force required by the operating device is considerably reduced.

In a circuit breaker according to the self-blasting principle of the kind to which the invention relates, the communication between the arc region and the pressure storage chamber takes place through a channel in the blast nozzle. By a particularly suitable embodiment of the invention, the inlet position of this channel in the pressure storage chamber will be displaced during an opening operation. In this way, a gas mixture which is more favourable for the arc extinction is obtained in the pressure storage chamber.

By way of example, the invention will now be described in greater detail with reference to the accompanying drawings showing in

45 Figure 1 an axial section through the central parts of a self-blasting circuit breaker of the kind to which the invention relates, the part of the figure to the right of the centre line showing the breaker in the closed position and the part of the figure to the left of the centre line showing the breaker in the open position,

Figure 2 schematically a circuit breaker according to Figure 1 with a simple operating mechanism of a kind known per se, for achieving different operating speeds for the movable contacts of the breaker,

50 Figures 3 and 4 a further development, according to the invention, of the embodiment of the operating mechanism shown in Figure 2,

Figure 5 curves of the movement of the operating current contact and the arcing contact, respectively, which curves are almost optimal with respect to dielectric strength and low operating energy,

55 Figure 6 a link mechanism for achieving the movement curves shown in Figure 5,

Figures 7a-7d the mutual positions of the movable breaker parts at four different points in time during an opening operation,

Figures 8a and 8b an additional embodiment of a circuit breaker according to the invention in closed and open position, respectively.

The self-blasting circuit breaker shown in Figure 1, like prior art circuit breakers, comprises a gas-tight breaking chamber housing 1, which at least partially consists of insulating material and which includes a fixed plug-shaped arcing contact 2 and an axially movable sleeve-shaped arcing contact 3. The movable contact 3 is connected to an operating device by way of a tubular contact rod 4 and an insulating pull rod (not shown). With the aid of the operating device, the movable contact may be displaced between the closed position shown to the right in the figure and the open position shown to the left in the figure.

The movable contact 3 supports an electrically insulating blast nozzle 5 with an annular channel 6 which connects the region where the arc is burning upon an opening operation to a pressure storage chamber 7, the volume of which is constant. The pressure storage chamber 7 is delimited in the radially inward direction by the blast nozzle 5 and in the radially outward direction by a hollow metal cylinder 8, which also surrounds a compression chamber 9 (the puffer volume). The upper part of the hollow cylinder 8 constitutes the movable operating current contact 10 of the breaker, which contact cooperates with a fixed operating current contact 11.

The pressure storage chamber 7 and the compression chamber 9 are coaxially arranged around the movable contact rod 4 and are separated by a wall 12 provided with openings, which are covered by an annular plate 13 serving as a nonreturn valve. This nonreturn valve 13 allows flow only in a direction from the compression chamber 9 to the pressure storage chamber 7.

The compression chamber 9 is delimited by a puffer cylinder 14 and an annular, stationary piston 15. The walls of the puffer cylinder consist of the outer hollow cylinder 8, an inner hollow cylinder 16 and the partition wall 12, which interconnects the hollow cylinders 8 and 16. The inner hollow cylinder 16 is connected to the operating device via a pair of pull rods 17.

In the circuit breaker shown in Figure 1, the movable arcing contact 3, the blast nozzle 5 and the contact rod 4 are built together and move at a high speed upon a opening operation. The movable operating current contact 10, the hollow cylinders 8 and 16 with the partition wall 12, which delimit the chambers 7 and 9, and the pull rods 17 move together at a lower speed.

Upon a breaking operation, the operating device (not shown) pulls the pull rods 17 which pull along with them the movable operating current contact 10 and the hollow cylinders 8 and 16 at a certain speed (indicated in Figure 1 by one single arrow). At the same time, the operating device pulls the contact rod 4 at a higher speed so that also the nozzle 5 and the movable arcing contact 3 are pulled downwards at this higher speed (indicated in Figure 1 by a double arrow).

The operating current contacts 10 and 11 open first, causing the current to commutate over to the arcing contacts 2 and 3. When the arcing contacts separate thereafter an arc is formed between them. At small breaking currents, gas from the compression chamber 9 blows through the nonreturn valve 13 and the pressure storage chamber 7 and further through the channel 6 towards the arc which is cooled and extinguished. At heavy breaking currents, the pressure storage chamber 7 is fed from the arcing zone with hot gas, the pressure in the pressure storage chamber 7 thus rising. The nonreturn valve 13 is closed such that the piston 15 need not work against this overpressure. Possibly, the puffer cylinder may be relieved through a relief valve in the piston 15. In case of decreasing instantaneous current value immediately before the current zero-crossing, the pressure in the nozzle 5 decreases and the overpressure in the pressure storage chamber 7 drives a flow of arc-extinguishing gas through the channel 6 into the arcing zone for extinction.

The different speeds of the two contact systems may be achieved in several different ways. Figure 2 shows an embodiment in which the different speeds are achieved in, in principle, the same way as in the above-mentioned DE-C-2 946 929 with the aid of toothed wheels 20, the centre pins of which are journaled in the pull rods 17. In case of an opening operation, the operating device pulls the pull rods 17, which pull along with them the movable operating current contact 10, the hollow cylinders 8 and 16 and the toothed wheels 20. The toothed wheels are in engagement with toothed surfaces 21 along the stand of the piston 15 and are thus set in rotary motion. In addition, the toothed wheels 20 are in engagement with toothed surfaces 22 on the outside of the hollow contact rod 4 and drive this contact rod 4 at double speed downwards.

The speed of the arcing contact 3 is determined by the rated voltage of the circuit breaker. In a breaker according to the invention, however, only parts 3 and 4 and, in this particular example, the nozzle 5 move at the high speed. The other movable parts may move at a lower speed. The operating energy can therefore be reduced compared with known designs, where all movable parts are moving at the speed prescribed by the rated voltage.

Another advantage is that the orifice of the channel 6 in the pressure storage chamber 7 changes its position relative to the pressure storage chamber during an opening operation. In that way, a better mixing is obtained of the hot gases flowing into the pressure storage chamber during the high current period and the cold

gas which fills the pressure storage chamber from the start. This is an advantage since it has proved that, in case of unfavourable designs with a stationary channel, the same hot gas may be returned for extinction as was blown into the pressure storage chamber during the high current period. This may jeopardize the arc extinction.

5 In the embodiment shown in Figure 2, the ratio between the speeds of the two movable contacts is 2:1. With a design in which the speed ratio is dependent on the current contact position, the demands on dielectric strength and low operating energy can be satisfied to an even better extent. Figures 3 and 4 show an improved embodiment of the toothed wheel design shown in Figure 2, in which such a change of the speed ratio during the opening operation is achieved. In this embodiment, the shaft pins 23 of the toothed wheels are eccentrically placed and run in slots 24 in the pull rods 17. The main direction of the slots is perpendicular to the longitudinal axis of the extinguishing chamber. The gear ratio in the gear unit at each time is equal to the ratio between the distances between the pin 23 and the contact surfaces 21, 22 of the tooth against the racks. In this way, the path/time curves can be optimized with respect to the demands for dielectric strength and low operating energy. A particularly favourable movement is obtained if the toothed wheels in the closed position of the breaker have a gear ratio of around 1:1 so that both contact systems move at approximately the same speed at the initial stage of an opening operation (Figure 3). Gradually, the gear ratio increases towards a value around 1:2 so that the movable arcing contact reaches its maximum speed immediately after the contact separation (Figure 4). Later on, when the contacts approach their open positions and the demands on the speed of the arcing contact are not as high, the gear ratio again decreases towards a value around 1:1.

10 Still a further improvement can be obtained if the movement curves (path s as a function of time t) for the operating current contact and the arcing contact, respectively, resemble the curves shown in Figure 5, where curve I relates to the operating current contact 10 and curve II to the arcing contact 3.

At the beginning of an opening operation when both contact pairs are still engaged (at A in Fig. 5), the operating current contact is accelerated towards its final speed whereas the arcing contact remains stationary or is accelerated only to a small extent. When the movable operating current contact separates from the fixed operating current contact (at B in Fig. 5), it has approximately reached its final speed and then continues at an even speed. At this stage, the movable arcing contact is accelerated to reach its high speed when, or immediately after, it separates from the fixed arcing contact (at C in Fig. 5). Near the end of the opening movement (at D in Fig. 5) the speed of the movable arcing contact is reduced.

20 The advantages of this type of movement curve are, inter alia, the following:

a) The length of stroke for the movable arcing contact may become smaller compared with a solution where the movable arcing contact is moving during all of the time when the movable operating current contact is moving.

25 b) The possibilities of adapting the geometry on the movable contact side are improved, so that the field stresses are always greater on the movable arcing contact than on the movable operating current contact. A possible flashover across the breaking point will then take place between the arcing contacts where the extinction capacity remains.

c) The rapid and the slow movable parts in the breaker are accelerated at different times. In this way, the maximum force required of the operating device can be reduced.

30 Figure 6 shows a link mechanism by which the movement curves shown in Figure 5 can be accomplished. The link mechanism is arranged adjacent to the lower connecting flange 26 of the extinguishing chamber, which flange is located between the extinguishing chamber casing 1 and a support insulator 27. Figure 6 shows the link mechanism in the closed position of the breaker in unbroken lines, as well as in the open position of the breaker in broken lines. The link mechanism comprises two link arms 31, 32 which are rotatably fixed to the flange 26 at points 33 and 34. The link arms are able to rotate in the plane of the drawing. The link arm 31 exhibits a slot 35, and the link arm 32 exhibits a pin with a roller 36 running in the slot 35. A pull rod 4 is linked to the arm 31 and connects the arm to the movable arcing contact in the breaker. A pull rod 17 is linked to the arm 32 and connects the arm 32 to the movable operating current contact in the breaker. A third pull rod 37 of insulating material is linked to the arm 32 and connects it to the operating device in the bottom part of the support insulator (not shown). The pull rods 4 and 17 are not shown in the open position.

35 When the breaker is to be operated from the closed position to the open position, the operating device pulls the pull rod 37. The arm 32 rotates around the point 34 and pulls along with it the pull rod 17, which operates the movable operating current contact. The roller 36 runs in the slot 35 such that the arm 31 rotates to a certain extent or not at all at the beginning. At a later stage the arm 31 starts rotating around the point 33 and pulls along with it the pull rod 4, which operates the movable arcing contact. The shape of the slot causes the speed of the rotary movement of the arm 31 at the end of the operation to be reduced whereas the arm 32 continues to rotate at full speed until the breaker has reached its open position.

40 Figures 7a-7d show the mutual positions of the movable contact systems at different times during an open-

ing operation with a breaker which is provided with the link mechanism shown in Figure 6. Figure 7a shows the closed position of the circuit breaker. Figure 7b shows the position at the moment when the arcing contacts 2, 3 separate (point C in Fig. 5). Figure 7c shows the position 14 ms after the opening moment of the arcing contacts. In this position, the injection of pressurized gas takes place at the very back of the pressure storage volume. Figure 7d finally shows the open position of the breaker.

The embodiment of a self-blasting circuit breaker shown in Figure 8 differs from that shown in Figure 1 substantially in that the blast nozzle 5 is built together with the pressure storage chamber 7 and in that the fixed arcing contact 2 is sleeve-shaped and the movable arcing contact 3 is plug-shaped. With the aid of an operating device, the movable contacts 3, 10 may be displaced between the closed position shown in Figure 8a and the open position shown in Figure 8b.

Upon a breaking operation, the operating device (not shown) pulls the pull rods 17 which pull along with them the movable operating current contact 10, the blast nozzle 5 and the hollow cylinders 8 and 16 with the partition wall 12, which delimit the chambers 7 and 9, downwards at a certain speed (indicated in Fig. 8a by one single arrow). At the same time, the operating device pulls the contact rod 4 at a higher speed such that also the movable arcing contact 3 is pulled downwards at this higher speed (indicated in Fig. 8a by a double arrow).

The embodiment shown in Figure 8 has the advantage compared with the embodiment shown in Figure 1 that a still smaller mass need be accelerated to a high speed.

The invention is not limited to the embodiments shown but several variants are possible within the scope of the inventive concept. For example, in the link mechanism according to Figure 6, the drive force from the operating device can be transmitted to the link arms 31, 32 through a rotating shaft to point 33 or 34 or through a pull rod which is connected to the link arm 31, in which case the configuration of the slot 35 should be changed accordingly.

Claims

1. High-voltage circuit breaker comprising

- a casing (1) filled with gaseous arc-extinguishing medium,
- two cooperating arcing contacts (2, 3), at least one (3) of which is adapted to be displaced in the casing between a closed and an open position by means of an operating device,
- a blast nozzle (5) arranged concentrically around the arcing contacts and being axially displaceable by means of the operating device,
- a blast chamber (14, 16) which is filled with extinguishing gas and which, by means of the operating device, is axially displaceable in the same direction as the movable arcing contact, and which via a channel (6) in the blast nozzle (5) communicates with that region where the arc is burning upon an opening operation, and
- two cooperating operating current contacts (10, 11) which upon an opening operation are arranged to separate earlier than the arcing contacts (2, 3), one (10) of the operating current contacts being connected to the blast chamber (14, 16) and moving at the same speed as the blast chamber, the movable arcing contact (3), at least during that part of the opening operation which immediately follows the moment of separation of the arcing contacts (2, 3), moving at a higher speed than the blast chamber (14, 16).

characterized in that the movable contacts (3, 10) are connected to the operating device in such a way that during the first part of an opening, when both contact pairs are still in engagement, substantially only the movable operating current contact (10), is accelerated, whereupon substantially only the movable arcing contact (3) is accelerated to reach its final speed at or immediately after the moment of separation of the arcing contacts (2, 3).

2. Circuit breaker according to claim 1, **characterized** in that the movable contacts are connected to the operating device via a link mechanism with two rotatably journalled links (31, 32), of which one link (32) is connected to the movable operating current contact (10) and to a pull rod (37) connected to the operating device and exhibits a pin (36) which is in engagement with a clearance slot (35) in the other link (31), which is connected to the movable arcing contact (3).

3. Circuit breaker according to claim 1, **characterized** in that the displaceable part (14) of the compression chamber is connected to the operating device via at least one pull rod (17), on which a toothed wheel (20) is journalled, which forms a mechanical coupling between the movable arcing contact (3) and the station-

ary part of the breaker, the toothed wheel having an eccentrically located shaft (23) which runs in a transversal bearing slot (24) in the pull rod (17).

- 5 4. Circuit breaker according to any of the preceding claims, **characterized** in that the blast chamber (14, 16) comprises a compression chamber (9), which is delimited by a blast piston (15) and a puffer cylinder (14), one of the delimiting parts (e.g. 14) being axially displaceable by means of the operating device.
- 10 5. Circuit breaker according to claim 4, **characterized** in that the blast chamber (14, 16) comprises a pressure storage chamber (7), which is located between the compression chamber (9) and the channel (6) arranged in the blast nozzle (5), the compression chamber (9) at least temporarily communicating with the pressure storage chamber (7).
- 15 6. Circuit breaker according to claim 5, **characterized** in that the pressure storage chamber (7) has a constant volume and is delimited partly by an external wall (8) which is fixed to the displaceable part (14) of the compression chamber (9), partly by an internal wall which is formed by the blast nozzle (5) and/or the movable arcing contact (3).

Patentansprüche

- 20 1. Hochspannungs-Leistungsschalter mit
- einem Gehäuse (1), das mit einem gasförmigen Lichtbogenlöschmedium gefüllt ist,
 - zwei zusammenarbeitenden Lichtbogenkontakten (2, 3), von den zumindest einer (3) mittels einer Betätigungsvorrichtung im Gehäuse zwischen einer geschlossenen und einer geöffneten Stellung
 - 25 verschiebbar ist,
 - einer Blasdüse (5), die konzentrisch um die Lichtbogenkontakte angeordnet ist und durch die Betätigungsvorrichtung axial verschiebbar ist,
 - einer Blaskammer (14, 16), die mit Löschgas gefüllt ist und durch die Betätigungsvorrichtung axial in derselben Richtung verschiebbar ist, wie der verschiebbare Lichtbogenkontakt, und die über einen
 - 30 Kanal (6) in der Blasdüse (5) mit dem Bereich in Verbindung steht, wo der Lichtbogen bei einem Öffnungsvorgang brennt, und
 - zwei zusammenarbeitenden Arbeitsstromkontakte (10, 11), die so angeordnet sind, daß sie bei einem Öffnungsvorgang früher trennen, als die Lichtbogenkontakte (2, 3), wobei einer (10) der Arbeitsstromkontakte mit der Blaskammer (14, 16) verbunden ist und sich mit derselben Geschwindigkeit
 - 35 wie die Blaskammer bewegt und wobei der bewegliche Lichtbogenkontakt (3) zumindest während des Teils des Öffnungsvorganges, der unmittelbar der Trennung der Lichtbogenkontakte (2, 3) folgt, sich mit einer höheren Geschwindigkeit als die Blaskammer (14, 16) bewegt,
- dadurch gekennzeichnet**, daß die beweglichen Kontakte (3, 10) derart mit der Betätigungsvorrichtung verbunden sind, daß während des ersten Teils eines Öffnungsvorganges, wenn beide Kontaktpaare sich
- 40 noch berühren, im wesentlichen nur der bewegliche Arbeitsstromkontakt (10) beschleunigt wird, wonach im wesentlichen nur der bewegliche Lichtbogenkontakt (3) beschleunigt wird, um seine Endgeschwindigkeit in oder unmittelbar nach dem Augenblick zu erreichen, in welchem die Trennung der Lichtbogenkontakte (2, 3) erfolgt.
- 45 2. Leistungsschalter nach Anspruch 1, **dadurch gekennzeichnet**, daß die beweglichen Kontakte mit der Betätigungsvorrichtung über einen Gliedermechanismus mit zwei drehbar gelagerten Gliedern (31, 32) verbunden sind, von denen das eine Glied (32) mit dem beweglichen Arbeitsstromkontakt (10) und einer Zugstange (37) verbunden ist, die an die Betätigungsvorrichtung angeschlossen ist, und einen Stift (36) hat, der durch einen Gleitschlitz (35) des anderen Gliedes (31) verläuft, welches mit dem beweglichen
- 50 Lichtbogenkontakt (3) verbunden ist.
3. Leistungsschalter nach Anspruch 1, **dadurch gekennzeichnet**, daß der verschiebbare Teil (14) der Kompressionskammer mit der Betätigungsvorrichtung über mindestens eine Zugstange (17) verbunden ist, in der ein Zahnrad (20) drehbar gelagert ist, welches eine mechanische Kopplung zwischen dem beweglichen Lichtbogenkontakt (3) und dem stationären Teil des Schalters bildet, wobei das Zahnrad eine ex-
- 55 zentrisch angeordnete Welle (23) hat, welche in einem quer verlaufenden Lagerschlitz (24) der Zugstange (14) läuft.

4. Leistungsschalter nach einem der vorhergehenden Ansprüche, **dadurch gekennzeichnet**, daß die Blaskammer (14, 16) eine Kompressionskammer (9) enthält, die begrenzt wird von einem Blaskolben (15) und einem Pufferzylinder (14), wobei eines der begrenzenden Teile (zum Beispiel 14) durch die Betätigungsverrichtung axial verschiebbar ist.
5. Leistungsschalter nach Anspruch 4, **dadurch gekennzeichnet**, daß die Blaskammer (14, 16) eine Druckspeicherkammer (7) hat, welche zwischen der Kompressionskammer (9) und dem Kanal (6) in der Blasdüse (5) angeordnet ist, wobei die Kompressionskammer (9) zumindest vorübergehend mit der Druckspeicherkammer (7) in Verbindung steht.
6. Lichtbogenkontakt nach Anspruch 5, **dadurch gekennzeichnet**, daß die Druckspeicherkammer (7) ein konstantes Volumen hat und teilweise durch eine äußere Wand (8) begrenzt wird, die an dem verschiebbaren Teil (14) der Kompressionskammer (9) fixiert ist, und teilweise durch eine innere Wand, die von der Blasdüse (5) und/oder dem beweglichen Lichtbogenkontakt (3) gebildet wird.

Revendications

1. Disjoncteur haute tension comprenant

- une enceinte (1) emplie d'un milieu gazeux d'extinction d'arc,
- deux contacts de formation d'arc (2, 3) qui coopèrent, l'un au moins (3) d'entre eux étant conçu pour être déplacé dans l'enceinte entre une position ouverte et une position fermée, au moyen d'un dispositif d'actionnement,
- une buse de soufflage (5) disposée de façon concentrique autour des contacts de formation d'arc et qui peut être déplacée en direction axiale au moyen du dispositif d'actionnement,
- une chambre de soufflage (14, 16) qui est emplie du gaz d'extinction et qui peut être déplacée axialement dans la même direction que le contact mobile de formation d'arc, au moyen du dispositif d'actionnement, et qui communique, par l'intermédiaire d'un canal (6) dans la buse de soufflage (5), avec la région dans laquelle l'arc brûle pendant une opération d'ouverture, et
- deux contacts de courant nominal (10, 11) qui coopèrent et qui sont montés de manière à se séparer plus tôt que les contacts de formation d'arc (2, 3) au moment d'une opération d'ouverture, l'un (10) des contacts de courant nominal étant connecté à la chambre de soufflage (14, 16) et se déplaçant à la même vitesse que la chambre de soufflage, le contact mobile de formation d'arc (3) se déplaçant à une vitesse supérieure à celle de la chambre de soufflage (14, 16), au moins pendant la partie de l'opération d'ouverture qui suit immédiatement le moment de la séparation des contacts de formation d'arc (2, 3),

caractérisé en ce que les contacts mobiles (3, 10) sont connectés au dispositif d'actionnement d'une manière telle que pendant la première partie d'une ouverture, lorsque les deux paires de contacts sont toujours en contact mutuel, pratiquement seul le contact mobile de courant nominal (10) est accéléré, après quoi pratiquement seul le contact mobile de formation d'arc (3) est accéléré pour atteindre sa vitesse finale au moment de la séparation des contacts de formation d'arc (2, 3), ou immédiatement après.

2. Disjoncteur selon la revendication 1, **caractérisé** ce que les contacts mobiles sont connectés au dispositif d'actionnement par l'intermédiaire d'un mécanisme de liaison articulé comportant deux bras articulés (31, 32) montés de façon tournante, parmi lesquels un bras articulé (32) est relié au contact mobile de courant nominal (10) et à une tige de traction (37) reliée au dispositif d'actionnement, et il présente un axe (36) qui coopère avec une fente de dégagement (35) dans l'autre bras articulé (31), qui est relié au contact mobile de formation d'arc (3).

3. Disjoncteur selon la revendication 1, **caractérisé** en ce que la partie (14) de la chambre de compression qui peut être déplacée est reliée au dispositif d'actionnement par l'intermédiaire d'au moins une tige de traction (17), sur laquelle une roue dentée (20) est montée de façon tournante, qui forme un accouplement mécanique entre le contact mobile de formation d'arc (3) et la partie fixe du disjoncteur, la roue dentée ayant un axe (23) disposé de façon excentrique qui se déplace dans une fente de support transversale (24) se trouvant dans la tige de traction (17).

4. Disjoncteur selon l'une quelconque des revendications précédentes, **caractérisé** en ce que la chambre de soufflage (14, 16) comprend une chambre de compression (9) qui est délimitée par un piston de souff-

flage (15) et un cylindre de bouffée (14), l'un des éléments de délimitation (par exemple 14) pouvant être déplacé axialement au moyen du dispositif d'actionnement.

5 5. Disjoncteur selon la revendication 4, **caractérisé** en ce que la chambre de soufflage (14, 16) comprend une chambre de stockage sous pression (7) qui se trouve entre la chambre de compression (9) et le canal (6) disposé dans la buse de soufflage (5), la chambre de compression (9) communiquant, au moins temporairement, avec la chambre de stockage sous pression (7).

10 6. Disjoncteur selon la revendication 5, **caractérisé** en ce que la chambre de stockage sous pression (7) présente un volume constant et elle est délimitée en partie par une paroi externe (8) qui est fixée à la partie (14) de la chambre de compression (9) qui peut être déplacée, et en partie par une paroi interne qui est formée par la buse de soufflage (5) et/ou le contact mobile de formation d'arc (3).

15

20

25

30

35

40

45

50

55

Fig. 1

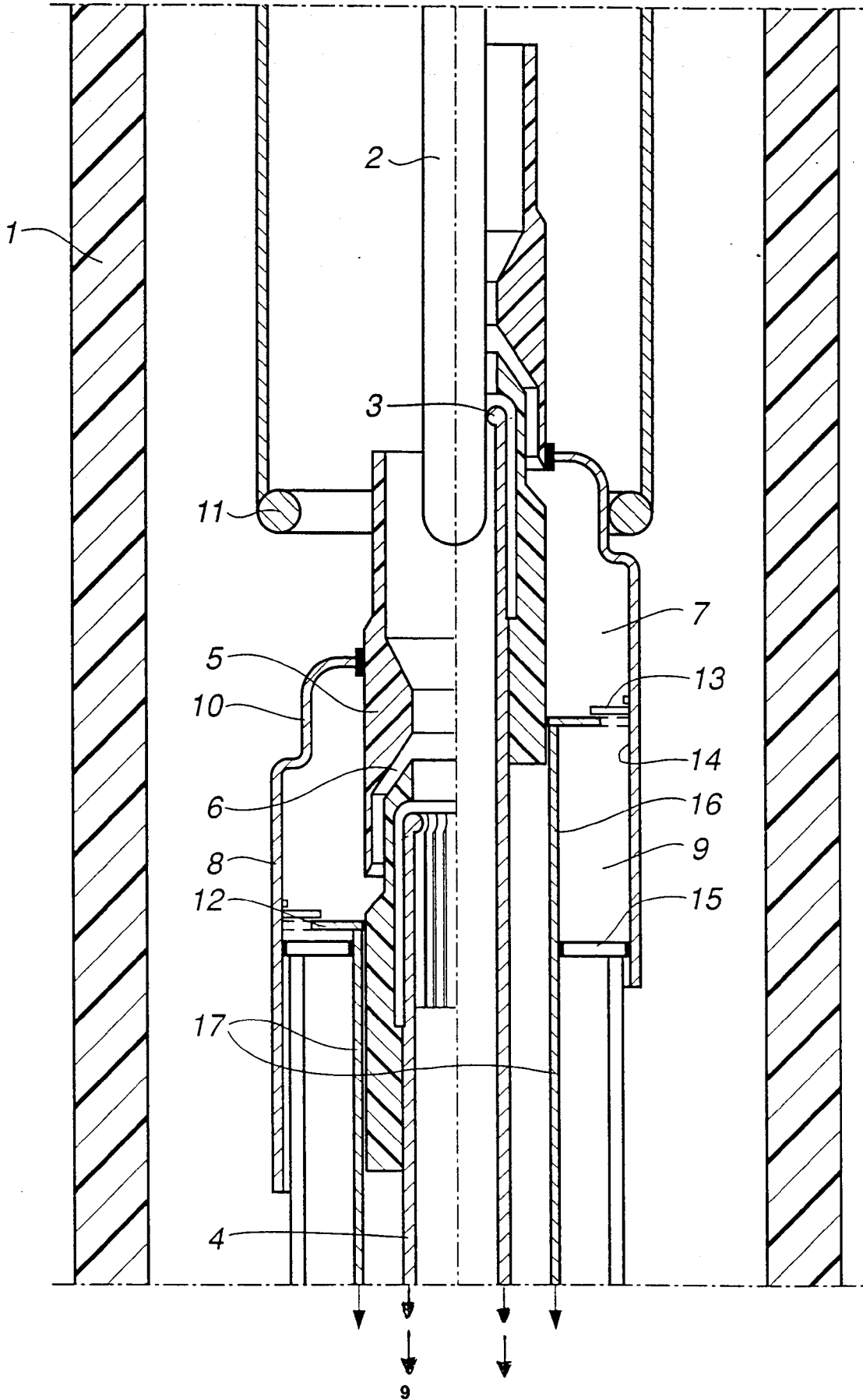

Fig. 2

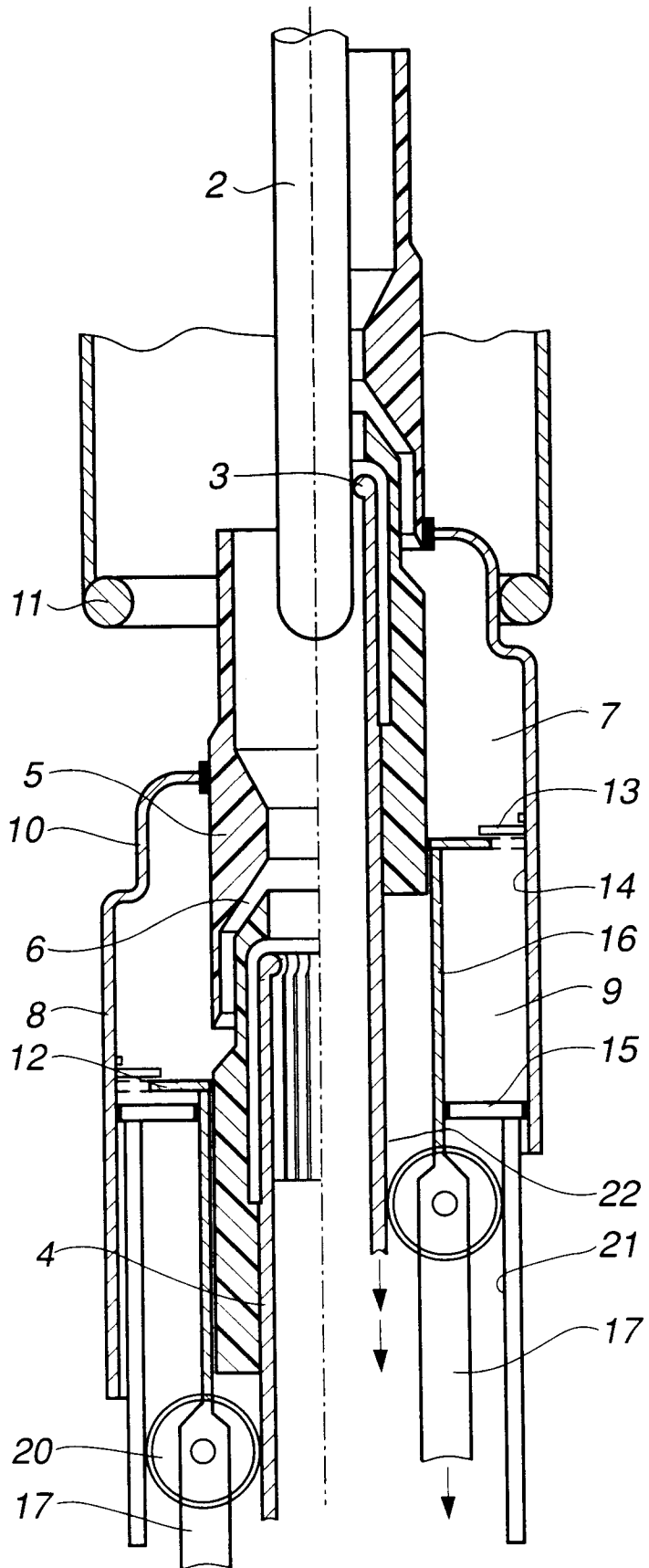

Fig. 3

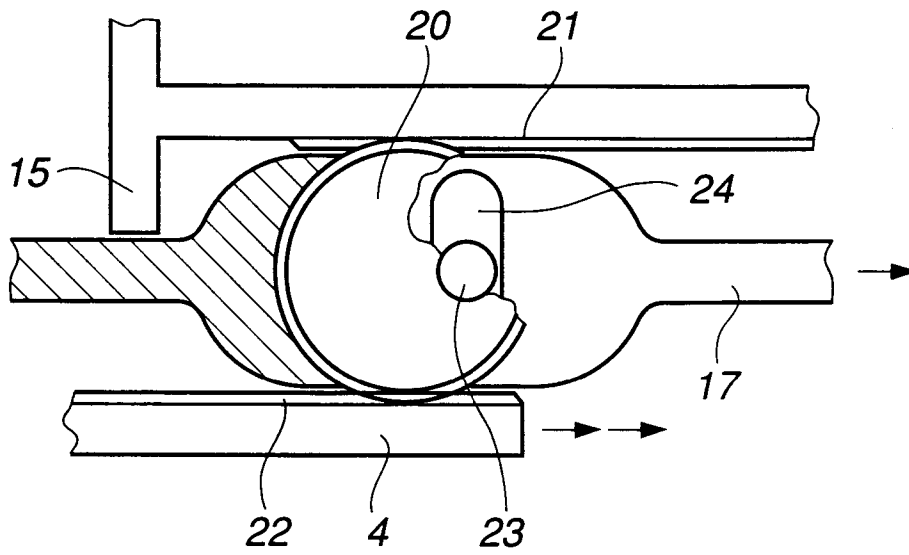

Fig. 4

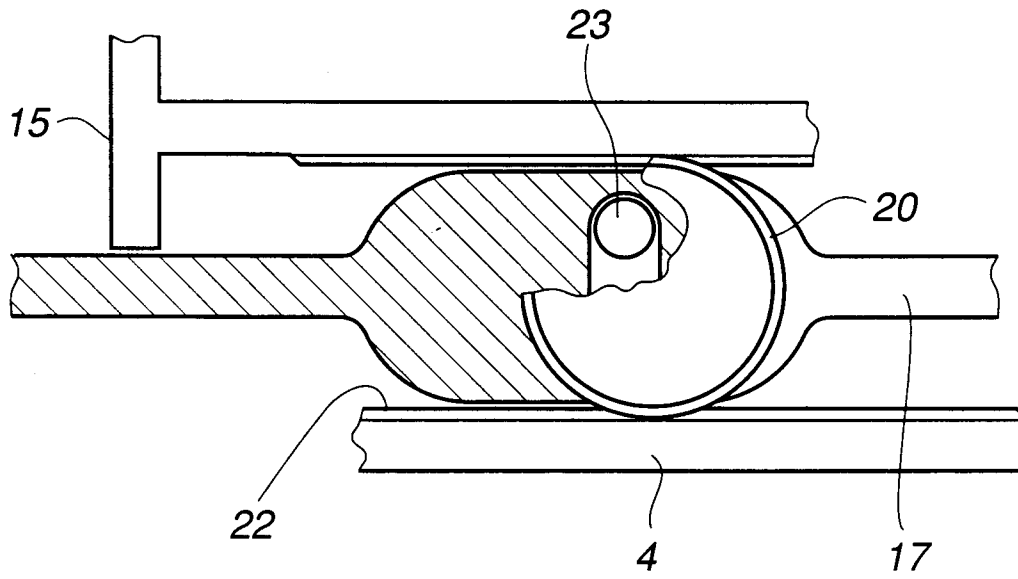

Fig. 5

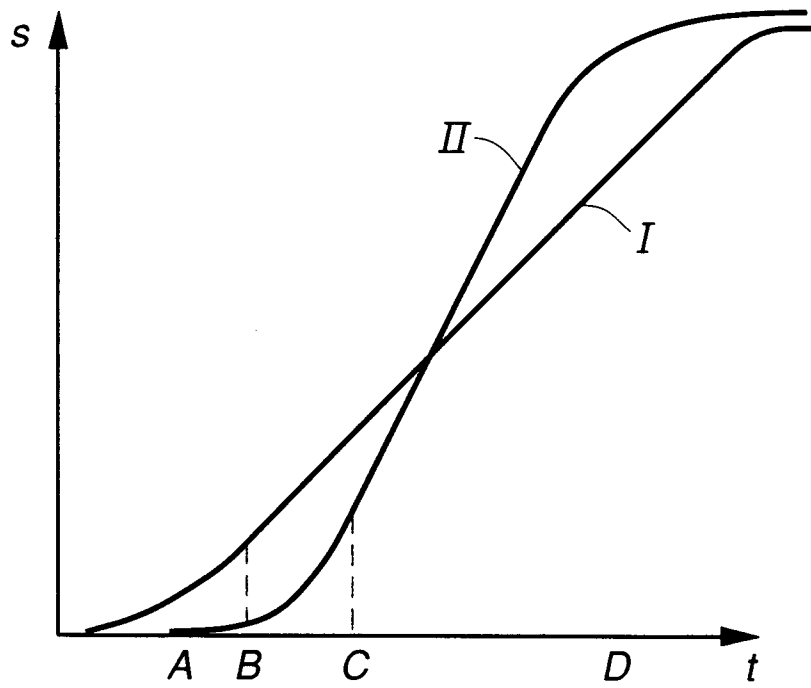
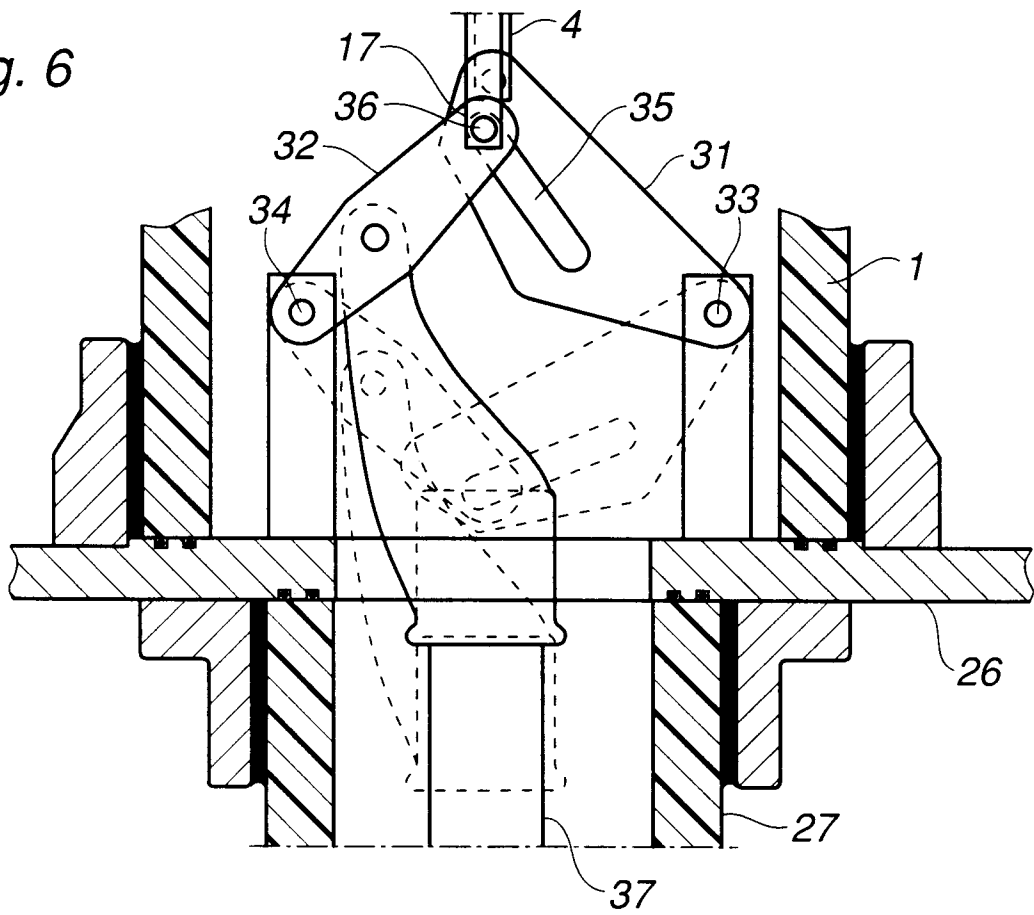

Fig. 6



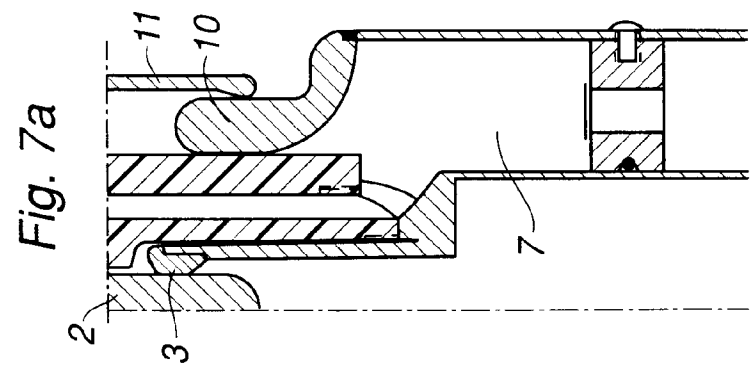
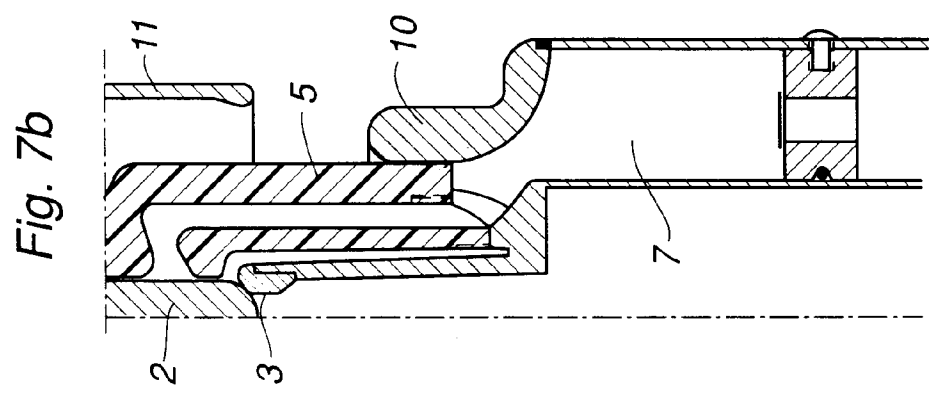
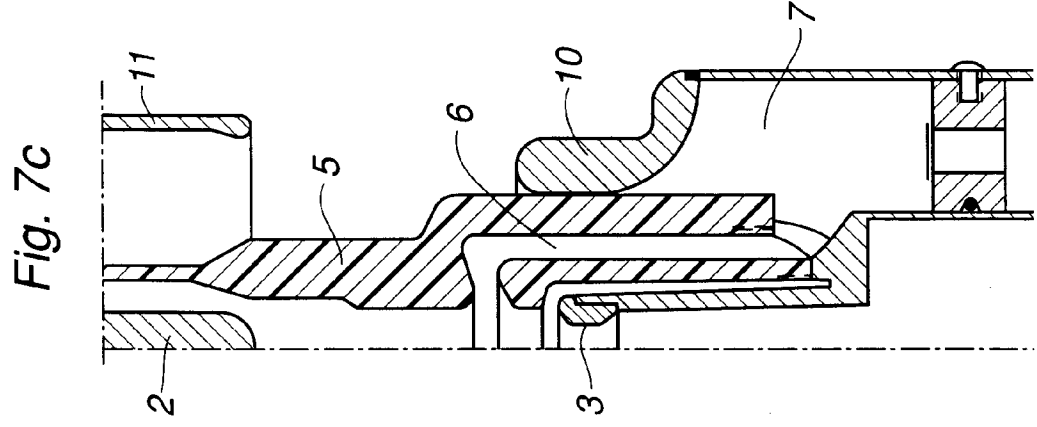
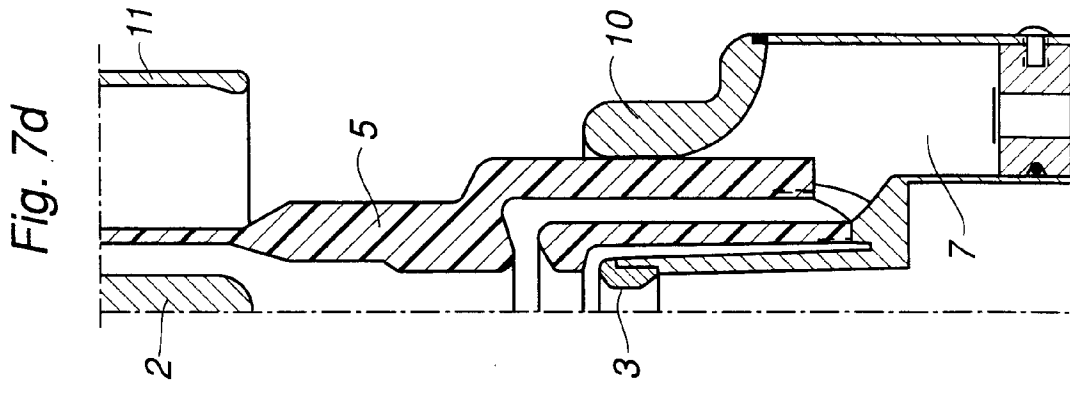

Fig. 8b

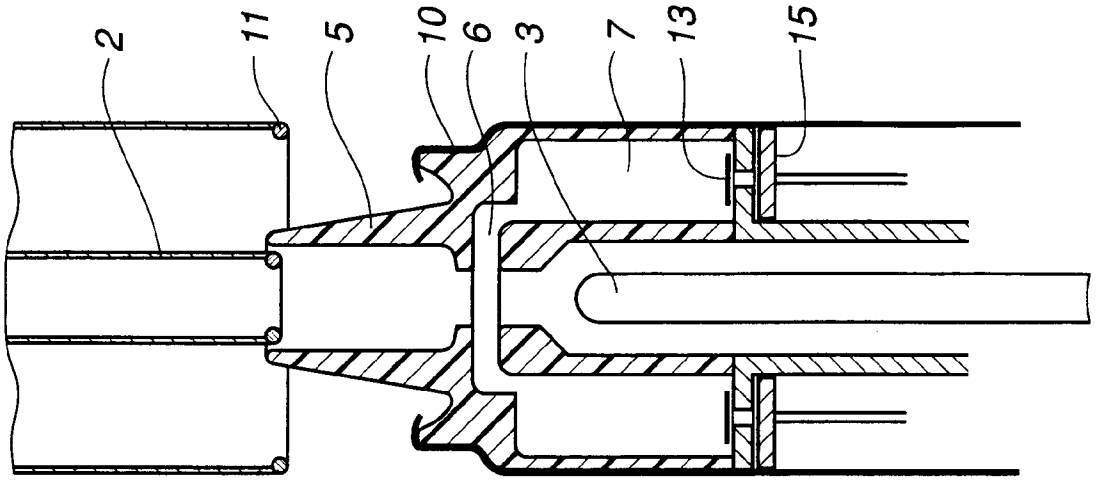

Fig. 8a

