

19



Europäisches Patentamt
European Patent Office
Office européen des brevets



11 Publication number:

0 488 998 A2

12

EUROPEAN PATENT APPLICATION

21 Application number: **92104562.1**

51 Int. Cl.⁵: **B41J 11/70**

22 Date of filing: **16.10.89**

This application was filed on 17 - 03 - 1992 as a divisional application to the application mentioned under INID code 60.

30 Priority: **14.10.88 JP 260173/88**

43 Date of publication of application:
03.06.92 Bulletin 92/23

60 Publication number of the earlier application in accordance with Art.76 EPC: **0 364 305**

84 Designated Contracting States:
DE FR GB IT

71 Applicant: **BROTHER KOGYO KABUSHIKI KAISHA**
No. 15-1, Naeshiro-cho, Mizuho-ku Nagoya-shi, Aichi-ken 467(JP)

72 Inventor: **Nagao, Yoshiaka, c/o Brother Kogyo K. K.**
No. 15-1 Naeshiro-cho, Mizuho-ku Nagoya-shi, Aichi-ken(JP)
Inventor: **Kobayashi, Atsuhiro, c/o Brother Kogyo K. K.**
No. 15-1 Naeshiro-cho, Mizuho-ku Nagoya-shi, Aichi-ken(JP)
Inventor: **Sakuma, Mikio, c/o Brother Kogyo K. K.**
No. 15-1 Naeshiro-cho, Mizuho-ku Nagoya-shi, Aichi-ken(JP)

74 Representative: **Senior, Alan Murray J.A. KEMP & CO., 14 South Square Gray's Inn London WC1R 5LX(GB)**

54 **Tape printing device.**

57 A tape printing device for providing a printed tape including a printing member (23, 23') for printing on one surface of a tape-like recording medium (3, 3') which is to be provided from a supply within the device, means to forward the recording medium into overlapping relation with a double-sided adhesive tape (13, 13') also to be provided from a supply within the device, so as to adhere said double-sided adhesive tape to the printed surface of the tape-like recording medium, means to pass the overlapped tapes to a cutting point in the device and a cutter system at the cutting point comprising a movable cutting member (51, 51') having a blade portion (53, 53') to act against a cutting block (55, 55') which is removable and replaceable.

FIG. 1

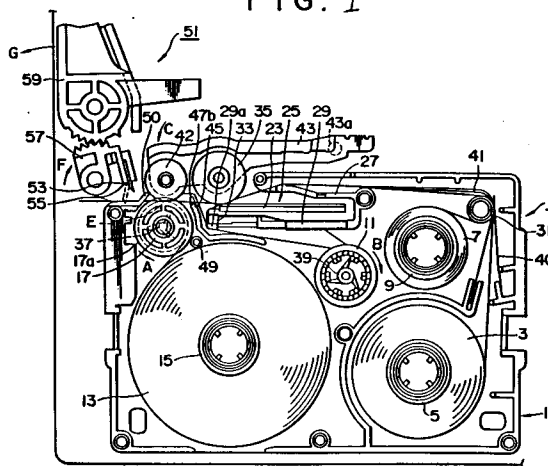

EP 0 488 998 A2

The present invention relates to a tape printing device including a tape cutter system and which is for preparing printed adhesive tapes which comprise two tapes which are overlapped and cut together.

Apparatus for printing on a non-adhesive side of an adhesive tape has been well-known. In this type of apparatus, although characters such as names can be printed on tapes which can be suitably adhered on the desired substrates, the printed characters can become erased or blurred because the printed surface is exposed. It has therefore been proposed to make adhesive printed tapes where the printed surface is not exposed. Characters may be reversely printed on one side of a transparent film tape to which side a double-sided adhesive tape of the same width is then adhered.

While the two tapes may be separately provided, usually in roll form, within the apparatus, one way to facilitate attachment of the double sided adhesive tape to the transparent printed tape is to provide them both in a replaceable cassette.

Whether or not the tapes are provided together in a cassette, they need to be led to a point where, after printing of the transparent tapes, they are overlapped and pressed together. Then, they need to be cut-off in order to provide a finished label which can be adhered, by the second layer of adhesive on the double-sided adhesive layer, to an article to be labelled.

The present invention concerns the cutting system employed.

According to this invention, there is provided a tape printing device for providing a printed tape including a printing member for printing on one surface of a tape-like recording medium which is to be provided from a supply within the device, means to forward the recording medium into overlapping relation with a double-sided adhesive tape also to be provided from a supply within the device, so as to adhere said double-sided adhesive tape to the printed surface of the tape-like recording medium, means to pass the overlapped tapes to a cutting point in the device and a cutter system at the cutting point comprising a movable cutting member having a blade portion to act against a cutting block which is removable and replaceable.

The invention will be better understood from the following description which is given by way of example with reference to the accompanying drawings in which:-

Fig. 1 is an explanatory view showing part of a printing device according to the present invention in which the tapes are supplied from a cassette; and

Fig. 2 is an explanatory view of another printing device according to the invention where again

the tapes are supplied from a cassette.

Figure 1 shows part of a device of this invention and in particular shows a tape storage cassette 1. This has a film tape spool 5 around which a transparent film tape 3 is fitted, a ribbon feed spool 9 having a thermal transfer inking ribbon 7 wound thereon with its inked surface facing inside, and a ribbon takeup spool 11 to take up the used thermal transfer ribbon 7. Also within the cassette is provided a double-sided adhesive tape spool 15. On this is a double-sided adhesive tape 13 which is narrower than the film tape 3 and has one adhesive surface covered with an exfoliative sheet. It is wound with this sheet covered surface facing towards the outside. An alignment roller 17 is for alignment of the double-sided adhesive tape 13 with the film tape 3. The spools 5, 9, 11 and 15 and the roller 17 are carried by support members mounted on a cover member (not shown) of the cassette and on the bottom of the cassette case 19 opposed to the cover.

The tape storage cassette 1 is attachably and detachably mounted on the printer device which is adapted to perform reverse-printing of desired characters. Thus, the unit accomplishes reverse-printing on the film tape 3 using the thermal transfer ribbon 7, and the double-sided adhesive tape 13 is then stuck to the printed surface to provide a print tape with desired characters printed.

The tape storage cassette case 1 is formed with a recess 25 to receive a thermal head 23 of the printer unit as shown in Fig. 1. Along the inner and outer periphery of the recess 25 are upright extending guide plates 27 and 29 to define a space for receiving the thermal head 23. The film tape 3 and the thermal transfer ribbon 7, with its interiorly wound surface coated with ink, are brought into face-to-face relation and are guided together to the recess 25 around a guide pin 31. The guide plates 27 and 29 define a path for the film tape 3, and the thermal transfer ribbon 7, to guide them around the recess 25 to avoid them blocking that space which accommodates the thermal head 23.

The guide plate 29 extends upright from the inner periphery of the recess 25 and is provided with a leaf spring 33 loading the film tape 3 and the thermal transfer ribbon 7 outward to maintain the required space for receiving the thermal head 23.

The thermal head 23 is thus located behind the thermal transfer ribbon 7. The film tape 3 and the thermal transfer ribbon 7 are then pressed against the thermal head 23 by means of a platen roller 35 provided on the printer and movable into and out of engagement with the thermal head 23, whereby desired reverse characters can be printed on the film tape 3.

The thermal transfer ribbon 7, having passed around the recess 25 to the print point where it

passes over the thermal head 23, is then taken up onto the ribbon takeup spool 11 via an end 29a of the guide plate 29. At the same time, the film tape 3 continues straight onwards and is drawn out of the cassette 1 by means of the alignment roller 17 which cooperates with a feed roller 42 on the device to be described.

The double-sided adhesive tape 13 also travels to the alignment roller 17. A guide roller 49 engages this tape and is made of silicon resin to prevent the double-sided adhesive tape 13 from inadvertently sticking to other parts such as the thermal transfer ribbon 7 in the cassette 1. The double-sided adhesive tape 13 is then guided to a position E between rollers 17 and 42 where it is overlapped with the film tape 3. The film tape 3 and the double-sided adhesive tape 13 are thus joined together by the alignment roller 17 and the feed roller 42 to form the printed adhesive tape. They are guided out of the cassette 1 by way of a tape holder 50 provided at the exit.

When attached to the printer unit, the alignment roller 17 and the inking ribbon takeup spool 11 are respectively engaged by splines to a tape feed element 37 and a ribbon takeup element 39 on the printer unit which are driven for rotation in opposite directions by a drive motor and power transmission mechanism, not shown, and are rotatably driven by these elements in the directions indicated by arrows A and B.

The thermal transfer ribbon 7 and the film tape 3 thus travel along the path consisting of the guide pin 31, the guide plate 27 and the thermal printing head at the end of the recess 25 due to such rotary drive motion. Inertia of such rotary motion however may cause an extra amount of thermal transfer ribbon 7 and film tape 3 to be drawn from the respective spools 5 and 7 once feeding stops. This results in slack of the ribbon 7 and the tape 3 in the recess 25, making it impossible to accomplish a proper printing action on the film tape 3. To overcome this problem, a leaf spring 40 is mounted near the guide pin 31, which presses against the thermal transfer ribbon 7 and the film tape 3 from outside, and loads then with back tension to prevent the thermal transfer ribbon 7 and the film tape 3 from being slackened at the recess 25. Furthermore, there is provided a separator film 41 which protects the film tape 3 from ink coating on the thermal transfer ribbon 7 during travel along the feed path between the position at which the film tape 3 is drawn from the film tape spool 5 and the recess 25. The film tape 3 and the thermal transfer ribbon 7 are given back tension independently of each other by means of the separator film 41 and the leaf spring 40 so that, even if one of them is drawn out for some reason, such pulling action does not affect normal feed motion of the other.

The alignment roller 17 is operatively associated with the feed roller 42 on the printer. This is movable into and out of engagement with the alignment roller 17 and is used to press the adhesive surface of the double-sided adhesive tape 13 against the print surface of the film tape 3. At its ends, the alignment roller 17 is provided with flanges 17a and 17b (not shown) mounted at right angles to the roller surface so as to restrict widthwise movement of the tapes 3 and 13. The feed roller 42 is carried by a support member 43 mounted on the printer and which is rotatable about an axis 43a. When the tape storage cassette 1 is attached to the printer unit, the support member 43 can be biased in the direction indicated by an arrow C by means of biasing means not shown, so that the film tape 3 and the double-sided adhesive tape 13 are pressed against the roller surface of the alignment roller 17 for bonding the tapes together.

The support member 43 also carries the platen roller 35 which has been previously discussed. Thus, the platen roller 35, like feed roller 42 is urged in the direction indicated by the arrow C to press the film tape 3 and the thermal transfer ribbon 13 against the thermal head 23. The platen roller 35 and the feed roller 42 can be formed of a resilient material such as rubber to avoid scratching the film tape 3 during pressing and to provide resistance and friction force.

In the feed path of the film tape 3 from the printing point at the end of the recess 25 to the alignment roller 17 is provided a guide plate 45 for guiding the film tape 3 to the joint position E where it meets the double-sided adhesive tape 13. The guide plate 45 is provided at both ends, i.e. one either side of the tape path, with restricting elements 47a (not shown) and 47b for restriction of widthwise displacement of the film tape 3. Since a length of the travel path of the film tape 3 is longer than that of the double-sided adhesive tape 13, it is advantageous for the film tape 3 to be aligned in a width direction before it is overlapped with the double-sided adhesive tape 13.

After overlapping and adhesion at position E, the two tapes which are united to form the printed tape follow a tape travel path outside the cassette case 19. In this embodiment, the cassette has a cutting block 55 against which can act a cutting blade 53 of a tape cutter 51 mounted on the printer unit. The printed tape can thus be cut off by pressing the cutting blade 53 against the block 55 by operation of the tape cutter 51. The tape cutter 51 is rotatably mounted on the printer unit, and consists of a cutting blade holder 57 carrying the cutting blade 53 and a rotary arm 59 for rotating the cutting blade holder 57 in the direction indicated by an arrow F. The print tape is cut off by

manually moving the rotary arm 59 in the direction indicated by an arrow G.

The tape storage cassette 1 of this embodiment is thus provided with the cutting block 55 which receives the cutting blade 53. The cutting block is thus removable and replaceable. When the printed tape is made by adhering the film tape 3 and the double-sided adhesive tape 13, it is fed and cut by the cooperating operations of the alignment roller 17, the block 55, and the feed roller 42 and the tape cutter 51. In the cassette 19, the film tape 3 is guided to the connection position E by the guide pin 31, the guide plate 27, and the guide plate 45. The double-sided adhesive tape 13 is guided to the connection position E by the guide roller 49 and the roller surface of the guide roller 49. The printed tape is then guided to the cutting block 55 through the tape holder 50.

When the tape storage cassette 1 is detached from the printer, another tape storage cassette, which may house a different color of thermal transfer ribbon, can be attached so as to make a different color printed tape. This is done by separating the platen roller 35 and the feed roller 42 from the tape storage cassette 1. The tape storage cassette 1 can then be directly detached with the film tape 3 and the double-sided adhesive tape 13 respectively guided to the connection position E. When the tape storage cassette 1 is attached to the printing apparatus again, it is not necessary manually to guide these tapes to the connection position E. In addition, since the tapes are guided by guide 50 from the connection position E to the cutting position, it is not necessary to arrange and connect the tapes 3 and 13 when attaching the tape storage cassette to the printer. Moreover, in the cassette case 19, since the film tape 3 is tensioned by the leaf spring 40 near the guide pin 31, when the tape storage cassette 1 is detached from the printer, the portion where the film tape 3 is connected to the double-sided adhesive tape 13 will not be fed outwardly, so that it is possible to keep the tape holding case 1 in the condition such that each tape is not discharged and the cassette can be removed without any difficulty arising as a result.

In the above first embodiment, the tape storage cassette 1 which is provided with the alignment roller 17 and the cutting block 55 for the cutting blade 53 has been described. The cutting block is therefore, in accordance with the present invention, replaceable and removable. This means that in this embodiment a fresh cutting block is provided with each cassette. Such portions, in particular the cutting block, can be provided on the printing apparatus itself rather than the cassette. In Fig. 2, parts the same as or similar to those in the above first embodiment are referred to with the same numbers

with apostrophes added. In all respects the parts in this embodiment function and have the same properties as the corresponding parts in the first embodiment.

As shown in Fig. 2, a printer to which a tape storage cassette 1' is attached is provided with an alignment roller 17' and a cutting block 55' for a cutting blade 53'. In this embodiment therefore the block is not on the cassette but is provided on the printer per se. A printed film tape 3' and a double-sided adhesive tape 13' can be drawn out from the tape storage cassette 1', pressed together and cut by the cutter.

In the tape storage cassette 1' of this second embodiment, guide plates 63 and 65 are provided extending from a concavity 25' to a take out opening of the film tape 3' so as to form a path for the film tape 3' to pass beneath an outer wall part 61 of the cassette 19'. Thus the printed film tape 3' is guided to the connection position E' where it joins with the double-sided adhesive tape 13' on the alignment roller 17'.

The travelling path of the double-sided adhesive tape 13' is defined by a guide pin 67, disposed to contact the side of the tape 13' which has the exfoliative sheet, the outer wall of the cassette case 19', and two guide rollers 69a and 69b made of silicone resin disposed to contact the adhesive side of the double-sided adhesive tape 13'. By guiding the double-sided adhesive tape 13' along the travelling path, it can be guided to the connection position E' with the film tape 3' on the alignment roller 17'.

Consequently, in the second embodiment, the tape storage cassette 1' can be detached from the printing apparatus in the condition that the film tape 3' and the double-sided adhesive tape 13' are guided to the connection position E' and connected to each other, thereby simplifying the attaching operation thereof. Subsequently the cassette, or a fresh one, can easily be applied.

Claims

1. A tape printing device for providing a printed tape including a printing member (23, 23') for printing on one surface of a tape-like recording medium (3, 3') which is to be provided from a supply within the device, means to forward the recording medium into overlapping relation with a double-sided adhesive tape (13, 13') also to be provided from a supply within the device, so as to adhere said double-sided adhesive tape to the printed surface of the tape-like recording medium, means to pass the overlapped tapes to a cutting point in the device and a cutter system at the cutting point comprising a movable cutting member (51,

51') having a blade portion (53, 53') to act against a cutting block (55, 55') which is removable and replaceable.

2. A device according to claim 1 wherein the cutter member (51, 51') is rotatable. 5
3. A device according to claim 1 or 2 wherein the means to pass the overlapped tapes includes a tape aligning member comprising a pair of flanges on a feed roller (17, 17') spaced apart substantially similarly to the width of the tapes. 10
4. A device according to claim 1, 2 or 3 wherein the surface of the double-sided adhesive tape (13, 13') opposite that to which the recording member (3, 3') is adhered is covered with an exfoliative sheet. 15
5. A device according to any preceding claim wherein in use said printing member (23, 23') executes reverse-printing operation on said surface of said recording member (3, 3') whereby the printing on said surface appears as normal from the opposite surface thereof. 20
25

30

35

40

45

50

55

5

FIG. 2

