

19



Europäisches Patentamt
European Patent Office
Office européen des brevets



11 Publication number:

0 491 100 A1

12

EUROPEAN PATENT APPLICATION

21 Application number: **90313919.4**

51 Int. Cl.⁵: **B43K 5/04, B43K 8/12**

22 Date of filing: **19.12.90**

43 Date of publication of application:
24.06.92 Bulletin 92/26

71 Applicant: **Sheu, Tyng-Jen**
11-7F, No. 3, Fu-Hsing-Erh-Rd, Ling-Ya Dist.
Kaohsiung City(TW)

84 Designated Contracting States:
AT BE CH DE DK ES FR GB GR IT LI LU NL SE

72 Inventor: **Sheu, Tyng-Jen**
11-7F, No. 3, Fu-Hsing-Erh-Rd, Ling-Ya Dist.
Kaohsiung City(TW)

74 Representative: **Barlow, Roy James et al**
J.A. KEMP & CO. 14, South Square, Gray's
Inn
London WC1R 5LX(GB)

54 **Fountain pen.**

57 A fountain pen includes a fountain pen barrel (50), an ink tube (60) provided inside the fountain pen barrel (50), a protrusion (52) projecting annularly inward from the fountain pen barrel (50) near one end thereof to hold the ink tube (60) in place, and a fountain pen head (50) joined to the other end of the fountain pen barrel (50). A pressing force is applied to move the ink tube (60) in an axial direction towards a writing core (82) which guides ink (62) from the ink tube (60) in a capillary flow. Axial movement of the ink tube (60) enables the protrusion (52) to generate a contracting force on the ink tube (60) to increase the releasing pressure of the ink (62). Excess ink absorbed by the writing core (82) permeates an ink absorbent member (81) disposed inside the fountain pen head (80) to prevent leakage of excess ink.

EP 0 491 100 A1

The present invention relates to a fountain pen, more particularly to a fountain pen wherein ink is released to the writing core by applying pressure.

Figure 1 shows a sectional view of a conventional fountain pen which comprises a hollow pen barrel 10 with a cotton sponge member 20 disposed inside the hollow space. A fountain pen head 30 is attached to the lower end of the pen barrel 10. A writing core 31, which is axially disposed inside the fountain pen head 30, has one end projecting out of the fountain pen head 30 and the other end in contact with the cotton sponge member 20. Ink is filled at the top end of the pen barrel 10 and is absorbed by the cotton sponge member 20. A cover 11 seals the top end of the pen barrel 10. The writing core 31 absorbs the ink from the cotton sponge member 20 and transfers it to a writing surface when the fountain pen is used.

The main drawbacks of the above described fountain pen are as follows:

1. If too much ink is absorbed by the writing core 31, ink may leak onto the writing surface or to a fountain pen cover, the former resulting in blotting.
2. A large portion of the cotton sponge member 20 is exposed to air, causing evaporation of ink. This means less efficiency in terms of ink usage.
3. The size of the cotton sponge member is relatively large. This makes it difficult to see if the ink poured during the ink replenishing process is adequate. Furthermore, the ink replenishing procedure takes up a lot of valuable time.

Therefore, the main objective of the present invention is to provide a fountain pen which has provisions for minimizing blotting, maximizing ink usage and ease of ink replenishment.

Accordingly, the preferred embodiment of a fountain pen of the present invention comprises a fountain pen barrel, a replaceable ink tube provided inside the fountain pen barrel, a first protrusion projecting annularly inward from said fountain pen barrel to hold the ink tube in place, and a fountain pen head having a writing core which receives ink from the ink tube. An urging means moves the ink tube in an axial direction towards the fountain pen head whenever a pressing force is applied thereto. The axial movement of the ink tube enables the first protrusion to generate a contracting force on the ink tube to increase the releasing pressure of the ink inside the ink tube. Excess ink absorbed by the writing core permeates an ink absorbent member disposed inside the fountain pen head.

Other features and advantages of the present invention will become apparent in the following detailed description of the preferred embodiments with reference to the accompanying drawings, in which:

Figure 1 is a sectional view of a conventional fountain pen;

Figure 2 is an exploded view of a first preferred embodiment of a fountain pen according to this invention;

Figure 3 is a sectional view of the fountain pen shown in Figure 2 to illustrate its assembly; and

Figure 4 is a sectional view of a second preferred embodiment according to the present invention.

Referring to Figure 2, the first preferred embodiment of a fountain pen according to the present invention is shown to comprise a fountain pen barrel 50, an ink tube 60, urging means 70 and a fountain pen head 80.

The fountain pen barrel 50 is formed as a hollow body with two open ends. A protrusion 51 projects annularly inward from the pen barrel 50 near the first open end thereof. The ink tube 60, which is made of a flexible material, is received inside the hollow space confined by the fountain pen barrel 50. An open end 61 of the ink tube 60 is substantially converging and is provided with an ink outlet opening 63 to serve as an outlet for ink 62 contained in the ink tube 60. The open end 61 of the ink tube 60 is in contact with a protrusion 52 which is substantially trapezoidal in cross section and projecting annularly inward from the pen barrel 50 near the second open end thereof.

The urging means 70 is received at the first open end of the fountain pen barrel 50 and effectively seals the same. The urging means 70 comprises a tubular wall casing 71, a pressure post 72, and a biasing means 73. The wall casing 71 has an annular shoulder 711 formed on a first end. The pressure post 72 comprises a hollow circular base 721 at one end. The wall casing 71 is sleeved over the pressure post 72.

The fountain pen head 80 is substantially funnel-shaped and is joined to the second open end of the fountain pen barrel 50 to effectively seal the same. An ink absorbent member 81 is disposed inside the fountain pen head 80. A pith-like writing core 82, formed as a slender pole, is disposed inside the ink absorbent member 81 and has two ends that project out of the fountain pen head 80.

Referring to Figure 3, ink 62 in the ink tube 60 is collected at the open end 61 of the same. The open end 61 contacts the protrusion 52 of the pen barrel 50. An opposite end of the ink tube 60 projects through the protrusion 51 of the pen barrel 50. The biasing means 73, which is a spring member, surrounds the portion of the ink tube 60 which projects above the protrusion 51. One end of the biasing means 73 is supported by the protrusion 51. The circular base 721 of the pressure post 70 rests on the opposite end of the biasing means 73.

The wall casing 71 is disposed between the pressure post 72 and the pen barrel 50. When the fountain pen head 80 is joined to the pen barrel 50, the writing core 82 maintains a gap with the ink outlet hole 63.

When using the first preferred embodiment, a pressing force is first applied to the pressure post 72. The pressing force exerted is transmitted to the ink tube 60 and to the ink 62 inside the tube. The pressing force enables the protrusion 52 to generate a contracting force on the ink tube 60 to force the ink 62 to drip out of the ink outlet opening 63. The dripping ink is absorbed by the writing core 82 and the ink absorbent member 81. The writing core 82 guides the absorbed ink in a capillary action for eventual writing use.

Because of the small size of the ink outlet opening 63, the adhesion of the ink molecules and the coagulation of the ink itself make it difficult for the ink 62 to pass through the ink outlet opening 63 without the application of external pressure. Furthermore, the air pressure inside the ink tube 60 is in equilibrium with the pressure outside the ink tube 60. Thus, no ink 62 drips out of the ink outlet opening 63. Excess ink absorbed by the writing core 82 permeates the ink absorbent member 81 to ensure that no blotting occurs.

Figure 4 is a sectional view of a second preferred embodiment of a fountain pen according to this invention. In this embodiment, the writing core 82 extends through the ink outlet opening 63 and is in constant contact with the ink 62 inside the ink tube 60. The ink absorbent member 81 also extends out of the fountain pen head 80 to surround a portion of the open end 61 of the ink tube 60. Since the writing core 82 is continuously fed with ink, it is not necessary to apply pressure frequently to the urging means 70. The continuous feeding of ink 62 to the writing core 82 ensures that a constant capillary flow of ink that will be transferred to the writing surface during use.

The advantages of using a fountain pen of the present invention are as follows:

1. When the first embodiment is in use, pressure is first applied to the urging means 70. The pressure applied is transmitted to the ink tube 60 to release droplets of ink 62. The released ink is absorbed by the writing core 81 and the ink absorbent member 82. When no pressure is applied to the pressure means 70, no ink will drip out of the ink outlet opening 63, thereby ensuring that no ink is wasted.
2. Only a small portion of the ink 62 contained by the ink tube 60 is exposed to air. Less evaporation of ink occurs, guaranteeing better efficiency in terms of ink usage.
3. The ink tube 60 is replaceable, thus eliminating the tedious and messy process of pouring

ink from an ink bottle to replenish the ink supply of an ordinary fountain pen.

4. The size of the ink absorbent member 81 is reduced, guaranteeing faster absorbency of the ink 62. Since the excess ink absorbed by the writing core 82 is absorbed by the ink absorbent member 81, no blotting occurs when using a fountain pen of the present invention.

Claims

1. A fountain pen, comprising:
 - an ink tube (60) made of a flexible material, said ink tube (60) having a substantially converging end (61), a small opening (63) at said converging end (61) for releasing ink, and a top end portion opposite from said converging end (61);
 - a fountain pen barrel (50) having a hollow space for receiving said ink tube (60);
 - a first protrusion (52) projecting annularly inward from said fountain pen barrel (50) and disposed near a first end of said fountain pen barrel (50) such that said converging end (61) of said ink tube (60) contacts said first protrusion (52);
 - means (70) for urging said ink tube (60) in an axial direction towards said first protrusion (52), said urging means (70) being received by said fountain pen barrel (50) on a second end opposite said first protrusion (52) and retractably contacting said top end portion of said ink tube (60) so that a pressing force applied on said urging means (70) is transmitted to said ink tube (60), and said axial movement enables said first protrusion (52) to generate a contracting force on said converging end (61) of said ink tube (60) to increase the releasing pressure of the ink (62) inside said ink tube (60) via said small opening (63) of said ink tube (60); and
 - a fountain pen head (80) joined to said first end of said fountain pen barrel (50), said fountain pen head (80) having an axially disposed pith-like writing core (82) which guides the released ink from said ink tube (60) in a capillary action, said pith-like core (82) being axially fixed inside said fountain pen head (80) and having a first end and a second end, said first end protruding from said fountain pen head (80) for writing purposes.
2. The fountain pen as claimed in Claim 1, further comprising an ink absorbent member (81) surrounding said pith-like core (82) to absorb excess ink released by said ink tube (60).
3. The fountain pen as claimed in Claim 1,

wherein:

said fountain pen barrel (50) further comprises a second inwardly projecting annular protrusion (51) disposed near the second end of said fountain pen barrel (50), said top end portion of said ink tube (60) protruding through said second protrusion (51); and

said urging means (70) further comprises: a biasing means (73) surrounding said protruding portion of said ink tube (60), said biasing means (73) having a first and a second end, said first end of said biasing means (73) being supported by said second protrusion (51); a pressure post (72) having a base (721) at one end, the lower peripheral edge of said base (721) resting on said second end of said biasing means (73); and a tubular wall casing (71) disposed between said fountain pen barrel (50) and said pressure post (72).

4. The fountain pen as claimed in Claim 2, wherein said second end of said pith-like core (82) projects through said small opening (63) of said ink tube (60), whereby the ink (62) inside said ink tube (60) can be released by capillary action without applying a pressing force on said urging means (70).

5. The fountain pen as claimed in Claim 4, wherein said ink absorbent member (81) extends upwards from said fountain pen head (80) and surrounds a portion of said converging end (61) of said ink tube (60).

6. The fountain pen as claimed in Claim 1, wherein said pith-like core (82) is axially aligned with said small opening (63) of said ink tube (60), said second end of said pith-like core (82) being separated from said small opening (63) with a gap, such that the ink (62) inside said ink tube (60) can be released by droplets only when said pressing force is applied on said urging means (70).

7. A fountain pen, comprising:

an ink tube (60) made of a flexible material, said ink tube (60) having an end (61) converging to a small opening (63) for releasing ink, and a top end portion opposite from said converging end (61);

a fountain pen barrel (50) having first and second open ends, and a hollow space for receiving said ink tube (60);

a first protrusion (51) projecting annularly inward from said fountain pen barrel (50) and disposed near said first end of said fountain pen barrel (50), said top end portion of said ink tube (60) protruding through said first protrusion (51);

a second protrusion (52) projecting annularly inward from said fountain pen barrel (50) and disposed near said second end of said fountain pen barrel (50), such that said converging end (61) of said ink tube (60) contacts said second protrusion (52);

means (70) for urging said ink tube (60) in an axial direction towards said second protrusion (52), said urging means (70) being received by said fountain pen barrel (50) on said first end and retractably contacting said top end portion of said ink tube (60) so that a pressing force applied on said urging means (70) is transmitted to said ink tube (60), and said axial movement enables said second protrusion (52) to generate a contracting force on said converging end (61) of said ink tube (60) to increase the releasing pressure of ink (62) inside said ink tube (60) via said small opening (63) of said ink tube (60);

a spring member (73) of said urging means (70) surrounding the portion of said ink tube (60) protruding through said first protrusion (51), said spring member (73) having a first and a second end, said first end of said spring member (73) being supported by said first protrusion (51);

a pressure post (72) component of said urging means (70) having two ends and a base (721) at one end, the lower peripheral edge of said base (721) resting on said second end of said biasing means (73);

a tubular wall casing (71) component of said urging means (70) being disposed between said fountain pen barrel (50) and said pressure post (72);

a fountain pen head (80) joined to said second end of said fountain pen barrel (50), said fountain pen head (80) having an axially disposed pith-like writing core (82) which guides the released ink from said ink tube (60) in a capillary action, said pith-like core (82) having a first end and a second end and being axially fixed inside said fountain pen head (80) and axially aligned with said small opening (63) of said ink tube (60), said first end of said pith-like core (82) protruding from said fountain pen head (80) for writing purposes, and said second end of said pith-like core (82) extending from said fountain pen head (80) toward said ink tube (60) and being separated from said small opening (63) by a gap, such that the ink (62) inside said ink tube (60) can be released by droplets only when said pressing force is applied on said urging means (70); and

an ink absorbent member (81) which surrounds a portion of said second end of said

pith-like core (82) to absorb excess ink released by said ink tube (60).

5

10

15

20

25

30

35

40

45

50

55

5

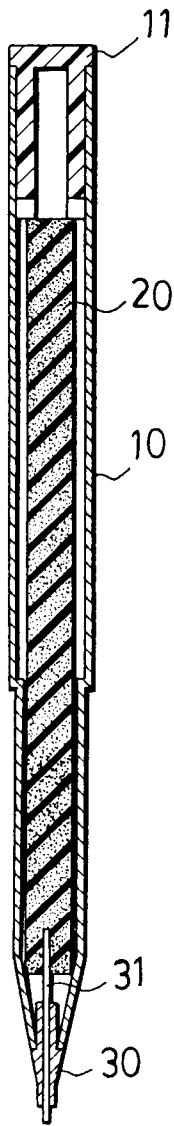

FIG. 1
PRIOR ART

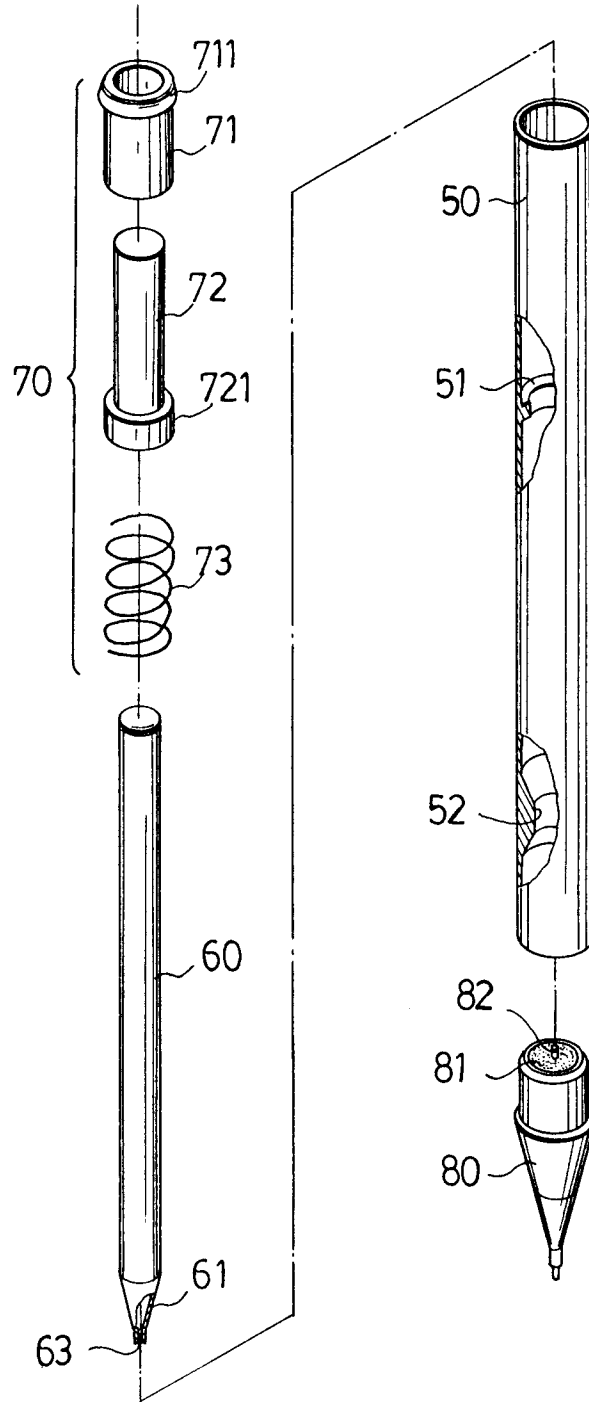

FIG. 2

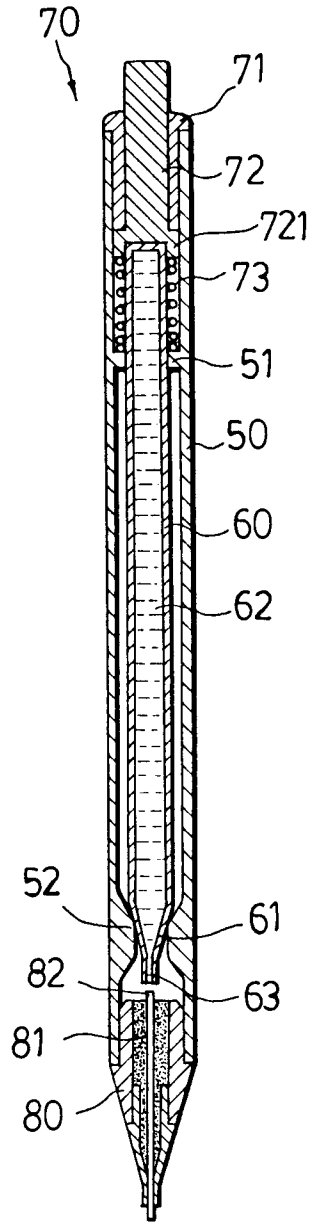

FIG . 3

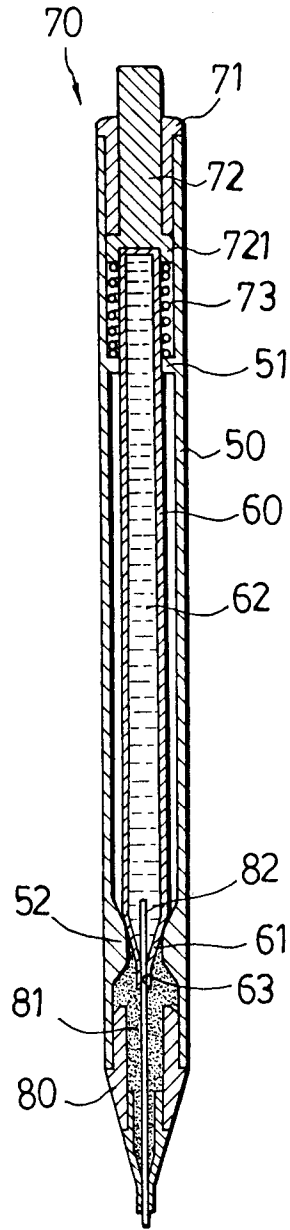

FIG . 4



DOCUMENTS CONSIDERED TO BE RELEVANT			
Category	Citation of document with indication, where appropriate, of relevant passages	Relevant to claim	CLASSIFICATION OF THE APPLICATION (Int. Cl.5)
Y	US-A-2 536 923 (FEHLING) * column 3, line 12 - column 5, line 59; figures 1,2 *	1,4	B43K5/04 B43K8/12
A	---	3,7	
Y,D	GB-A-1 108 598 (BLOCHER) * claims; figures *	1,4	
A	---	3,7	
A	US-A-1 811 992 (BELL) * claims; figures 1,2 *	1,2,5	
A	GB-A-2 194 138 (JOHNSTON HONG) * claims; figure 1 *	1,4	
A	FR-A-1 023 144 (AUFFRET ET ETLIN) * the whole document *	1,7	
A	FR-A-2 596 705 (MITSUBISHI PENCIL) * page 13, line 6 - line 15; figure 2 *	1	
A	FR-A-2 612 089 (PARFUMS CHRISTIAN DIOR) * page 4, line 22 - line 28; figures 1,2 *	2,5	
			B43K A45D
The present search report has been drawn up for all claims			
Place of search THE HAGUE		Date of completion of the search 04 SEPTEMBER 1991	Examiner PERNEY Y.
CATEGORY OF CITED DOCUMENTS		T : theory or principle underlying the invention E : earlier patent document, but published on, or after the filing date D : document cited in the application L : document cited for other reasons & : member of the same patent family, corresponding document	
X : particularly relevant if taken alone Y : particularly relevant if combined with another document of the same category A : technological background O : non-written disclosure P : intermediate document			