



Europäisches Patentamt
European Patent Office
Office européen des brevets



Publication number:

0 491 400 A1

12

EUROPEAN PATENT APPLICATION

21 Application number: **91121835.2**

51 Int. Cl.⁵: **B65H 75/22**

22 Date of filing: **19.12.91**

30 Priority: **19.12.90 US 630221**

71 Applicant: **ANDREW A.G.**
Postfach 51, Bachliwis 2B
CH-8184 Bachenbulach, Zürich(CH)

43 Date of publication of application:
24.06.92 Bulletin 92/26

72 Inventor: **Harvey, David F.**
110 Inwood drive
Joliet, Illinois 60435(US)

84 Designated Contracting States:
DE FR GB IT

74 Representative: **Patentanwälte Grünecker,**
Kinkeldey, Stockmair & Partner
Maximilianstrasse 58
W-8000 München 22(DE)

54 **Collapsible metal reel.**

57 Reel (10) having a pair of end flanges (11,12) with a plurality of mounting brackets (17) spaced radially inwardly from the outer periphery thereof and spaced circumferentially from each other, and a central hub (13) having mounting brackets (19) at

opposite ends thereof for mating with the mounting brackets (17) on the end flanges (11,12), the mating pairs of the mounting brackets (17,19) being attachable to, and detachable from, each other by removable connecting bolts (41).

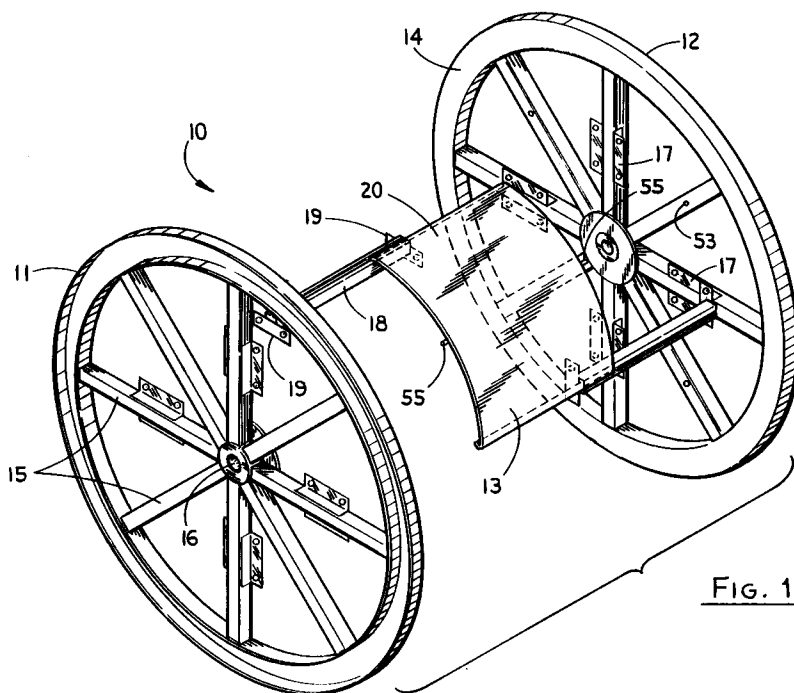

FIG. 1

EP 0 491 400 A1

Field Of The Invention

The present invention relates generally to collapsible reels for storing and transporting flexible cables such as co-axial cables used in the telecommunications industry. This invention particularly relates to such reels which are made of metal so that they have a long useful life, and which can be readily modified for different applications so that they do not remain idle for prolonged periods.

Background of the Invention

Metal reels are used extensively for cable shipment. Because these reels are of considerable size and weight, it is desirable that the empty reel is collapsible to conserve shipment or storage space. It is also preferable that a reel is adjustable in axial dimension and hub diameter to provide several reel configurations from a minimum number of component parts. U.S. Pat. Nos. 3,565,363, 3,940,085, 4,066,224 and 4,198,012 disclose collapsible reels which do not have interchangeable parts or variable hub diameters. A reel with interchangeable parts which is not adjustable and non-collapsible is disclosed in U.S. Pat. No. 3,970,267. An adjustable, non-collapsible reel is described in U.S. Pat. No. 4,221,347.

Summary Of The Invention

It is a primary object of the present invention to provide an improved collapsible metal reel which can be readily modified to form reels of different widths (the axial dimension of the reel) and different inside diameters.

It is another object of this invention to provide an improved collapsible metal reel in which oxidation of the metal parts does not impair the usefulness, nor the versatility, of the reel.

A further object of this invention is to provide an improved collapsible metal reel which provides parts which are interchangeable for different applications, i.e., the same parts can be used to form reels of different widths and diameters.

Still another object of this invention is to provide an improved collapsible metal reel which is rugged and durable so that it has a long operating life.

A still further object of this invention is to provide an improved collapsible metal reel which is totally collapsible in that the ends or "flanges" of the reel are readily detachable from the central hub which interconnects the two flanges.

Yet another object of this invention is to provide an improved collapsible metal reel which is particularly useful in forming reels of relatively large size, e.g., several feet in diameter.

A further object of the invention is to provide an improved collapsible metal reel in which the detachable parts are self-aligning when they are attached to each other so that end flanges are always parallel to each other and the hub is always perpendicular to the end flanges.

Other objects and advantages of the invention will be apparent from the following detailed description and the accompanying drawings.

In accordance with the present invention, the foregoing objectives are realized by providing a collapsible metal reel comprising a pair of end flanges having a plurality of mounting brackets spaced radially inwardly from the outer periphery thereof and spaced circumferentially from each other, and a central hub having mounting brackets at opposite ends thereof for mating with the mounting brackets on the end flanges, the mating pairs of the mounting brackets being attachable to, and detachable from, each other by removable connecting bolts.

Brief Description Of The Drawings

FIG. 1 is a perspective view of a collapsible metal reel embodying the present invention, with metal end flange covers removed;

FIG. 2 is an end elevation of the reel shown in FIG. 1;

FIG. 3 is a fragmentary exploded perspective of the interlocking mechanism between the metal panels and the elongated support members;

FIG. 4 is a fragmentary exploded view of mating pairs of the mounting brackets with connecting bolts; and

FIG. 5 is a perspective view of the interior side of an end flange having a cover.

Description Of The Preferred Embodiment

While the invention is susceptible to various modifications and alternative forms, a specific embodiment thereof has been shown by way of example in the drawings and will be described in detail. It should be understood, however, that it is not intended to limit the invention to the particular form described, but, on the contrary, the intention is to cover all modifications, equivalents, and alternatives falling within the spirit and scope of the invention as defined by the appended claims.

Turning now to the drawings and referring first to FIG. 1, a reel 10 generally comprises a pair of rigid end flanges 11 and 12 interconnected by a central hub 13. As shown in FIG. 1, the end flanges 11 and 12 of the reel 10 do not include covers, which will be described below in connection with FIG. 5. Each end flange comprises a circumferential rim 14 to which a plurality of radial support

members 15 are rigidly connected. To interconnect the plurality of radial support members 15, a central support member 16 is formed at the intersection of the radial support members. In order to connect the end flanges 11 and 12 to the central hub 13, a plurality of mounting brackets 17 are welded to a plurality of the radial support members 15. The positioning of the mounting brackets 17 determines the degree of adjustability of the hub diameter, as will be described in more detail below.

To form a central hub 13 which is both collapsible and adjustable in both width and diameter, the hub comprises a plurality of elongated rigid support members 18 which interconnect end flanges 11 and 12, defining the width of the reel 10. In order to connect the rigid support members 18 to the end flanges 11 and 12, mounting brackets are formed by attaching a pair of parallel plates 19 at opposite ends of each of the support members 18. A plurality of curved metal panels 20 interlock with support members 18 to form the radially outer surface of the hub 13, as will be described in detail below. When interlocked, the curved metal panels 20 form a smooth outer surface of the hub 13 which provides a snag-free environment for the cable.

As can be seen in the fragmentary exploded perspective view of FIG. 3, an elongated support member 18 is connected to two metal panels 20 to form a portion of the hub 13. The rolled edges 31 of the metal panels 20 are slid into a groove 32 of the elongated support member 18 so that the curved metal panels 20 are rigidly attached to the elongated support members 18 to form a central hub 13 between the end flanges 11 and 12. As shown most clearly in FIG. 1, each of the four curved metal panels 20 attaches to two of the four support members 18 to form a 90 degree section of the circumferential outer surface of the central hub 13. Each of the curved metal panels 20 includes two pins 55 which fit into holes 53 to support the center of each metal panel 20 providing additional support to the hub 13.

In accordance with a further feature of the invention, the mounting brackets 17 of the end flanges 11 and 12 include a plurality of holes by which the elongated support members 18 are attached to the end flanges so that a hub of variable diameter is formed. When it is desired to adjust the diameter of hub 13, each of the elongated support members 18 can be connected to one of a plurality of holes circumferentially spaced in each mounting bracket 17. The curved metal panels that are the proper size to slide into the grooves 32 of the support members 18 are so positioned to form the desired hub diameter. In positioning the panels, the pins 55 of each metal panel 20 are fitted into one of a plurality of circumferentially spaced holes in each radial support member 15 which does not

include a mounting bracket 17.

Thus, in the illustrative embodiment, each of the support members 18 is connected to either a radially inner hole 21 or a radially outer hole 22 of mounting brackets 17 of the end flange 11. When the support members 18 are connected to the outer holes 22, the larger 90 degree curved metal panels 23 are slid into the grooves 32 of the support members 18 to form a central hub 13 of diameter d_1 . The pins 55 (FIG. 1) of the metal panels 23 are fitted into the outer holes 26 of each radial support member that does not include a mounting bracket. A central hub of diameter d_2 is formed when the support members are connected to the inner holes 21 and the smaller 90 degree curved metal panels 24 are slid into the grooves 32 of the support members 18. The inner holes 25 of each radial support member that does not include a mounting bracket receive the pins 55 (FIG. 1) of the metal panels 24.

To provide a reel 10 of variable width, the length of the elongated support members 18 and the accompanying curved metal panels 23 or 24 can be extended or shortened. The mounting brackets 17, when circumferentially spaced on radial support members 18, determine the hub diameter adjustability. By attaching the mounting brackets 17 at a different position along the radial support members 18 than that shown in FIG. 2, two different hub diameters will result. It can be seen that the physical configuration of the reel can be altered in diameter and width without the use of special equipment. The interchangeability of the parts provides a versatile and easily modified collapsible reel.

As can be seen most clearly in FIG. 4, a bolt 41 may be passed through one of the holes 42 on one side of a mounting bracket 17, a hole 43 of a parallel plate 19 and a washer 44. The bolt 41 is threaded onto a nut 45 to firmly attach an elongated support member 18 to a radial support member 15 of an end flange 11. As described above, the bolt 41 and the nut 45 may connect an elongated support member 18 to either of holes 21 or 22 (see FIG. 2) to provide a hub 13 of diameter d_1 or d_2 .

To control winding tension, a drive plate 46 extends between two radial support members (see FIG. 4). In order to wind the cable, machinery is used which comprises three arm-like extensions. Two of the arm-like extensions hold the reel 10 in a desired position by locking into the recessed circular area 47 of the central support member 16 of the end flanges 11 and 12. The third arm-like extension of the winding machinery extends through the hole 47 of the drive plate 46 and moves in a winding motion to facilitate the cable winding and control the winding tension.

In accordance with a further feature of the invention, each of the end flanges 11 and 12 of the reel 10 also includes a metal cover. In the illustrative embodiment, FIG. 5, a metal cover 51 is attached to the inner surface of an end flange 11 so as to protect the cable.

The metal cover 51 is comprised of four sections which each cover one-quarter of the inner surface of the end flange 11. In order to facilitate repair, only a damaged section of the metal cover 51 must be replaced, eliminating the need for replacement of the entire cover. The metal cover 51 also comprises sixteen holes 54 to correspond with the holes in the four mounting brackets 17 so that the four elongated support members 18 may be connected to the end flange 11 as described above in connection with FIG. 4. Moreover, eight holes 53 are included in metal cover 51 to connect the pins 55 (FIG. 1) of each curved metal panel 20 to the end flange 11 as described above in connection with FIG. 1.

The circumferential rim of each of the end flanges is preferably made from a weldment of steel channel to provide a rigid base on which the reel rolls. The metal covers add strength to the end flanges while providing protection to the cable. A long operating life is provided by the durable construction of the parts of the reel.

The collapsible metal reel 10 is assembled by placing the radially outer side of the end flange on a flat surface and bolting the plurality of elongated support members to the end flange as shown in FIG. 4. The metal panels that are sized to slide into the grooves of adjacent elongated support members are then slid into the grooves until they contact the radially inner side of the end flange. When the metal panels contact the end flange, the pin on each panel fits into the corresponding hole of a radial support member. Another end flange is placed on top of the plates on the ends of the elongated support members such that the pin on each metal panel fits into the corresponding hole of a radial support member of the end flange. The end flange is bolted in place. The reel is then fully assembled and ready for use. The parts of the reel are self-aligning during assembly so that the end flanges are always parallel to each other and the hub is always perpendicular to the end flanges.

In an alternative embodiment, the covers of the end flanges are included in the assembly of the collapsible reel. Initially, a metal cover section is aligned on top of a corresponding section of the radially inner side of an end flange so that the holes in the metal cover section are aligned with the holes in the radial support members and the mounting brackets of the end flange as shown in FIG. 5. This metal cover section is then welded onto the end flange. Each metal cover section is

likewise aligned and welded until the end flange contains an complete metal cover. Next, the sections of a metal cover are aligned and welded to the opposing end flange.

The radially outer side of an end flange is placed on a flat surface. Four elongated support members are bolted to the end flange, as shown in FIG. 4, and then four metal panels that are sized to slide into the grooves of the elongated support members are slid into the grooves until they contact the radially inner side of the end flange. When the metal panels contact the end flange, the pin on each panel fits into the corresponding hole of a radial support member. The radially inner side of the second end flange with the welded metal cover is placed on top of the plates on the end of the elongated support members such that the pin on each metal panel fits into the corresponding hole of a radial support member of the second end flange. To complete the assembly, the holes of the second end flange with the metal cover are aligned with the holes in the plates of the elongated support members and are secured with bolts and nuts as shown in FIG. 4. Disassembly after removal of cable from the reel merely involves a reversal of the assembly operation. The reel is laid on a flat surface and the nuts and bolts are removed from an end flange. The end flange is then removed from the hub. The metal panels are slid out of the grooves of the elongated support members, and the nuts and bolts which secure these support members are removed so as to detach the support members from the other end flange. The disassembly of the reel is completed. To prevent difficulty in removing the metal panels from the grooves of the elongated support members, the grooves are wide enough to loosely secure the metal panels such that the panels are not tightly fitted into the grooves. This interlocking mechanism between the panels and the grooves allows the rolled edges of the metal panels to move freely within the grooves of the elongated support members so that oxidation of the metal panels and the elongated support members during the useful life of the collapsible reel will not cause these parts to adhere to each other and prevent the disassembly of the reel.

As can be seen from the foregoing detailed description, the present invention provides collapsible metal reels with interchangeable parts so that they may be modified to form reels of different widths and inside diameters. The reels are readily disassembled when the cable is unwound to facilitate economical transportation, storage and re-use of the reels.

The foregoing description is not limited to the specific embodiments herein described. A larger or smaller number of radial support members may be present. A different number of elongated support

members may be attached to the radial support members such that curved metal panels of greater or lesser than a ninety degree portion of the hub circumference are slid into the grooves. The curved metal panels may contain a plurality of pins which fit into corresponding holes of a radial support member to provide additional support for the central hub. To increase the hub diameter adjustability, the radial support members may contain more than one mounting bracket. Each mounting bracket may comprise more than two holes. The metal end flange covers may be welded or attached by alternate means to either side of the end flange. The metal covers may contain a plurality of holes for attaching the end flanges to any or all of the mounting brackets of the radial support members. A number of drive plates may be welded on each end flange although only one is necessary to facilitate the winding of cable.

Claims

1. A collapsible metal reel comprising:

a pair of end flanges having a plurality of mounting brackets spaced radially inwardly from the outer periphery thereof and spaced circumferentially from each other, and

a central hub having mounting brackets at opposite ends thereof for mating with said mounting brackets on said end flanges, such that each of said mounting brackets on said hub and a corresponding one of said mounting brackets on said end flanges form a mating pair, the mating pairs being attachable to, and detachable from, each other by removable connecting bolts, so that the end flanges are detachable from the central hub after said metal reel has been exposed to oxidation.

2. The reel of claim 1 wherein each of said end flanges comprises a circumferential rim, a plurality of radial support members rigidly connected to said rim and extending inwardly therefrom, and a central support member interconnecting the radially inner ends of said radial support members.

3. The reel of claim 1 wherein said central hub comprises a plurality of elongated rigid support members for interconnecting the pair of end flanges, each of said elongated rigid support members having opposite ends, each of said opposite ends having a plate rigidly attached thereto, said plates being parallel and forming said mounting brackets on said hub.

4. The reel of claim 3 wherein said central hub includes a plurality of metal panels forming a

radially outer surface of the hub, each of said panels extending circumferentially between a pair of adjacent elongated rigid support members and being connected thereto.

5. The reel of claim 4 wherein each of said elongated rigid support members has a groove extending along the outer surface thereof, such that ends of said panels are captured in said grooves to hold the panels in place.

6. The reel of claim 1 wherein said mounting brackets of said end flanges have a plurality of holes, such that said mounting brackets of said hub are attachable to, and detachable from, one of said plurality of holes.

7. The reel of claim 6 wherein said plurality of metal panels form a radially outer surface of the hub which results when said mounting brackets of said hub are attached to any of the holes in said mounting brackets of said end flanges.

8. A collapsible metal reel comprising:

a pair of end flanges wherein each end flange includes a circumferential rim, a plurality of radial support members rigidly connected to said rim and extending inwardly therefrom, a plurality of mounting brackets connected to said radial support members spaced circumferentially from each other, and a central support member interconnecting radially inner ends of said radial support members, and

a central hub having a plurality of elongated rigid support members for interconnecting a pair of end flanges and a plurality of metal panels forming a radially outer surface of the hub, each of said panels extending circumferentially between a pair of adjacent elongated rigid support members and being connected thereto, so that the end flanges are detachable from the central hub after said metal reel has been exposed to oxidation.

9. The reel of claim 8 wherein each of said elongated rigid support members has a groove extending along an outer surface thereof, such that ends of said panels are captured in said grooves to hold the panels in place.

10. The reel of claim 8 wherein each end flange includes a metal cover which is welded onto a radially inner side of said end flange.

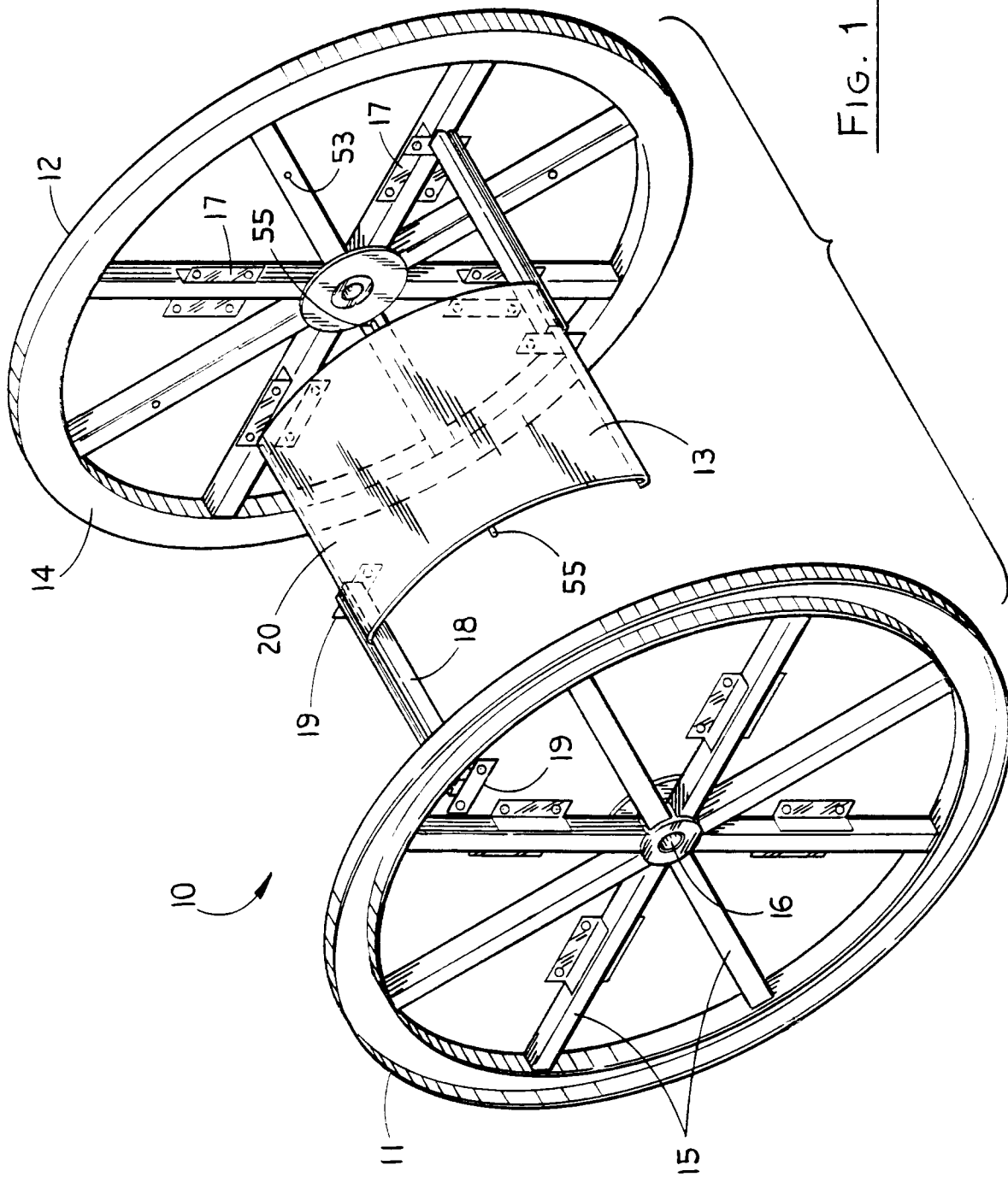

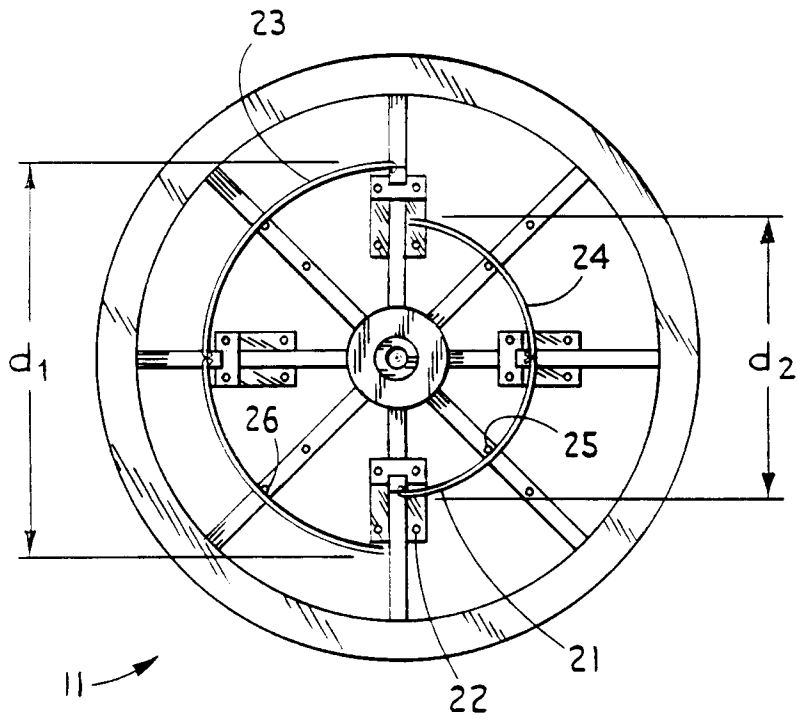

FIG. 2

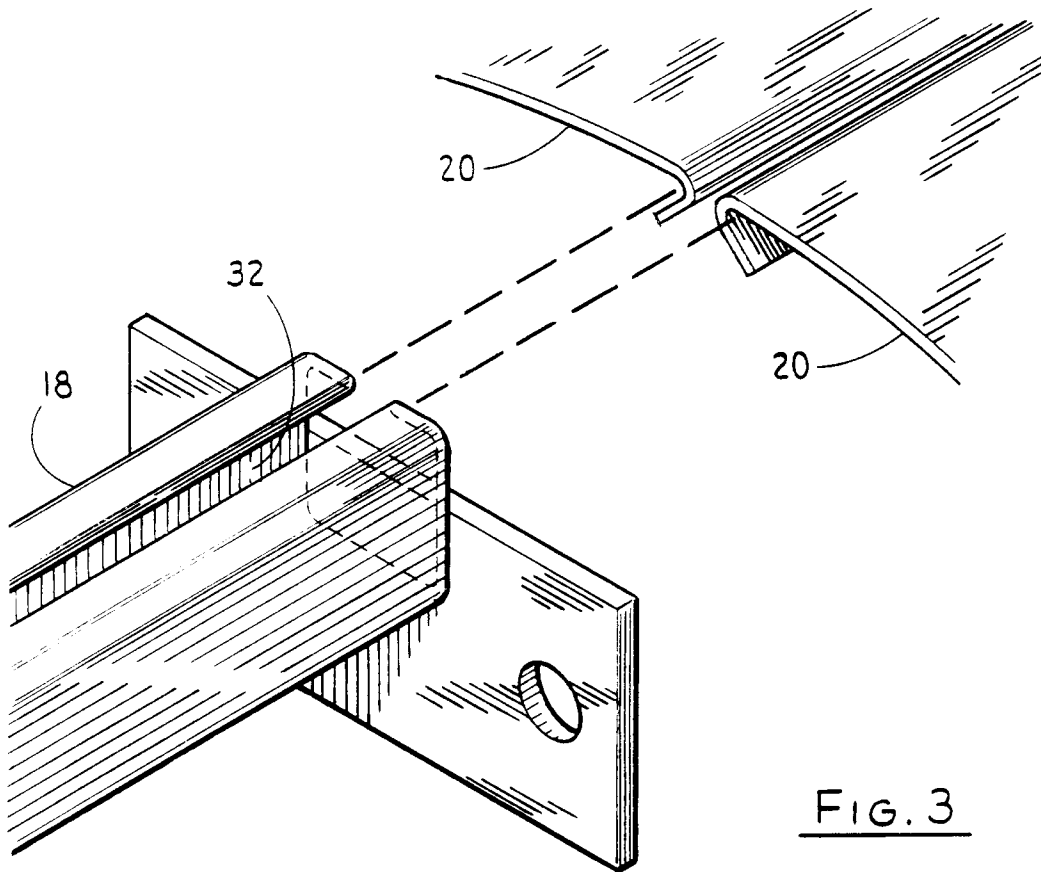
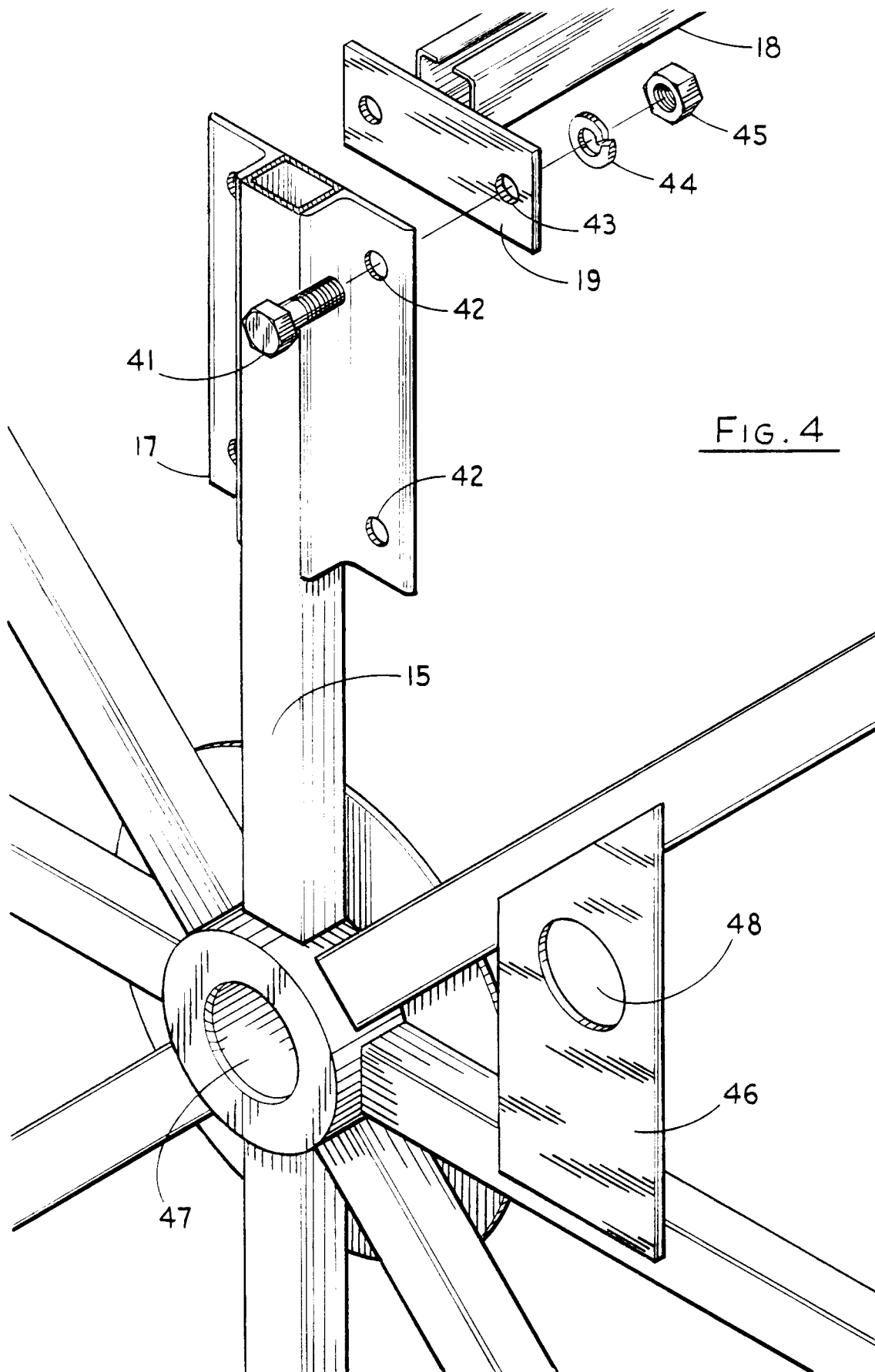
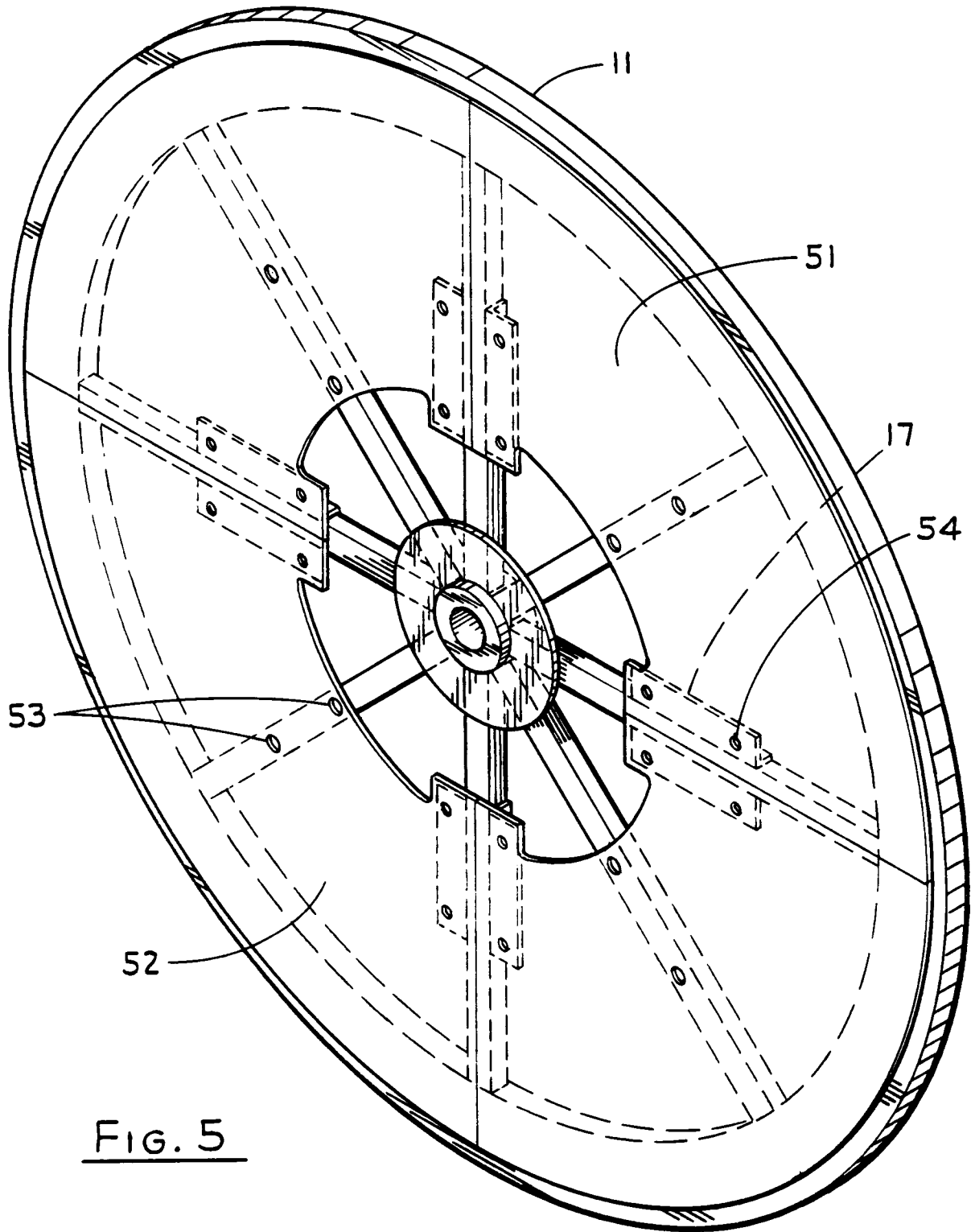

FIG. 3







DOCUMENTS CONSIDERED TO BE RELEVANT			
Category	Citation of document with indication, where appropriate, of relevant passages	Relevant to claim	CLASSIFICATION OF THE APPLICATION (Int. Cl.5)
X	DE-C-587 371 (BAHNE JACOBSEN) * whole document *	1,6	B65H75/22
Y		2-5,7	
A		8	
Y	--- US-A-3 240 444 (R. L. GENTILE) * column 1, line 63 - column 2, line 23; figures 1,2 *	2,8-10	
A		1	
Y	--- US-A-2 156 363 (G. G. TUCKER) * page 1, column 1, line 38 - page 2, column 1, line 8; figures *	3-5,7-10	
A		1	
A	--- PATENT ABSTRACTS OF JAPAN vol. 5, no. 80 (M-70)(752) 26 May 1981 & JP-A-56 028 172 (IKESAN) 19 March 1981 * abstract *	1,6-8	
A	--- DE-A-1 949 665 (SIEMENS) * figures 1,2 *	1,8	

			B65H
The present search report has been drawn up for all claims			
Place of search BERLIN		Date of completion of the search 03 MARCH 1992	Examiner FUCHS H.
CATEGORY OF CITED DOCUMENTS		T : theory or principle underlying the invention E : earlier patent document, but published on, or after the filing date D : document cited in the application L : document cited for other reasons & : member of the same patent family, corresponding document	
X : particularly relevant if taken alone Y : particularly relevant if combined with another document of the same category A : technological background O : non-written disclosure P : intermediate document			