



EUROPEAN PATENT APPLICATION

Application number : **91830562.4**

Int. Cl.⁵ : **D01H 5/00**

Date of filing : **17.12.91**

Priority : **21.12.90 IT 6805090**

Inventor : **Vedani, Augusto**
Via San Francesco 16
I-20022 Castano Primo, (Milano) (IT)

Date of publication of application :
01.07.92 Bulletin 92/27

Representative : **Notaro, Giancarlo et al**
c/o Jacobacci-Casetta & Perani S.p.A. Via
Alfieri, 17
I-10121 Torino (IT)

Designated Contracting States :
BE DE FR IT

Applicant : **SANT'ANDREA NOVARA S.p.A.**
Via Leonardo da Vinci 18
I-28100 Novara (IT)

A device for manipulating an end of a sliver of textile fibres.

The device includes a first gripper (8) for gripping a portion of the sliver (2) which extends over a base plate (4), a second gripper (22) which is adapted to grip the sliver (2) near the point where it has been gripped by the first gripper (8) and then to be moved away from the first gripper so as to tear the sliver, and a third gripper for gripping the end of the sliver which has previously been torn by the second gripper (22).

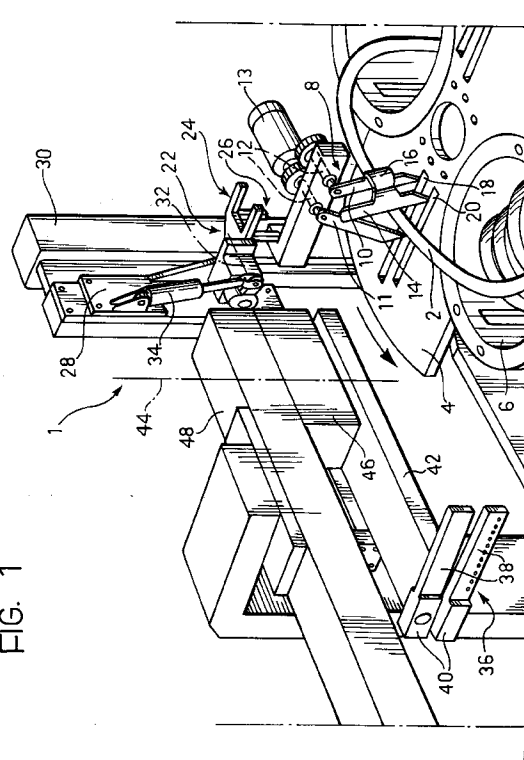

FIG. 1

The present invention relates to a device for manipulating an end of a sliver of textile fibres.

The device according to the present invention has been developed particularly for manipulating a sliver in continuously-operating drawing equipment which is the subject of a copending patent application by the present Applicant.

The object of the present invention is to provide a device which can automatically break a sliver and transfer an end of the sliver to an entrainment device.

According to the present invention, this object is achieved by the provision of a device which includes:

- a first gripper for gripping a portion of the sliver which extends over a base plate,
- a second gripper which is movable between a waiting position and an operative position adjacent the first gripper, in which the second gripper can grip the sliver near the point where it has been gripped by the first gripper,
- means for moving the second gripper between its waiting position and its operative position and vice versa, so that the sliver is torn when the second gripper is returned to its waiting position after gripping the sliver, and
- a third gripper for gripping the end of the sliver which has previously been torn by the second gripper and supplying it to an entrainment device.

By virtue of these characteristics and as will become clear from the following description, during the stages in which the sliver is transferred from one gripper to the other, the end of the sliver is held by both the grippers and one gripper releases its grip only when the next gripper has already gripped the end of the sliver. The points at which the grippers grip the sliver are thus determined precisely and the device operates in an accurate and reliable manner.

Further characteristics and advantages of the present invention will become clear in the course of the detailed description which follows with reference to the appended drawings provided purely by way of non-limiting example, in which Figures 1 to 5 are schematic, perspective views showing the operating sequence of the device according to the present invention.

With reference to the drawings, a device, indicated 1, is for breaking a sliver 2 of textile fibres and transferring an end of the sliver to an entrainment device, not shown. In the embodiment illustrated in the drawings, the sliver 2 which comes from a portion of the equipment which is not shown, extends over a horizontal base plate 4 and is collected in a container 6. Above the base plate 4 is a first gripper 8 constituted by a pair of arms 10, 11 articulated about respective parallel, horizontal axes 12. An actuator 13 pivots the arms 10, 11 about their respective axes 12. A third arm 14 is connected to the arm 10 by a bridge element 16. The base plate 4 has a pair of parallel slots 18, 20 in which end portions of the arms 10, 11

and 14 extend.

A second gripper, indicated 22, is constituted by a pair of jaws 24, 26, each of which has a pair of parallel arms arranged in a fork-like configuration. The gripper 22 is carried by a slide 28 which is slidable on a vertical guide upright 30 and is movable between an inoperative, raised position shown in Figures 1 and 2 and an operative, lowered position, shown in Figure 3. The means which cause the slide 28 to slide along the upright 30 are not shown in the drawings since they could be constituted by any known movement system such as, for example, a motor-driven chain. The jaw 24 is fixed relative to the slide 28 but the jaw 26 is articulated about an axis 32 and is pivoted about that axis by a fluid actuator 34 carried by the slide 28.

A third gripper, indicated 36, is constituted by a pair of plates 38 which are carried by respective supports 40 and are movable relative to each other like shears. The gripper 36 is carried by an arm 42 which is pivotable about a vertical axis 44 on a slide 46. The slide 46 is slidable along a fixed guide beam 48.

The operation of the manipulation device will now be described with reference to Figures 1 to 5.

In the configuration shown in Figure 1, the sliver 2 extends over the base plate 4 between the arms 10, 11 of the first gripper 8. Starting from the configuration of Figure 1, the first gripper 8 is closed and grips the sliver 2 as shown in Figure 2.

The second gripper 22 is then brought to its operative position shown in Figure 3. In this position, the arms of the first jaw 24 extend between the arms 10, 14 of the first gripper 8 and are above the sliver 2. The arms of the second jaw 26, however, are inserted in the slots 18, 20 in the base plate 4. At this point, the actuator 34 is activated and partially closes the second gripper which grips the portion of the sliver which is between the arms 10 and 14 of the first gripper 8. The second gripper 22 is then raised and, during this movement, the first gripper 8 is kept closed whilst the sliver slides between the jaws 24 and 26 until a programmed level is reached, when the jaws close completely, tearing the sliver. As shown in Figure 4, the sliver is thus torn in a region between the programmed level and the first gripper 8. The shape of the gripper 22 enables the portion 2a of the sliver between the two pairs of arms of the jaws 24 and 26 to be kept taught. The arm 42 is then pivoted about its axis 44 so as to bring the plates 38 of the third gripper 36 between the fork-shaped arms of the second gripper 22 (Figure 5). The third gripper 36 is then closed so as to grip the end of the sliver 2 and the second gripper 22 is then opened. The arm 42 pivots again so as to return to the configuration shown in Figures 1 to 4 whilst the third gripper 36 remains closed; the slide 46 is then moved so as to bring the end of the sliver 2 near to an entrainment device to which the end of the sliver which is held by the third gripper 36 is supplied.

Claims

1. A device for manipulating an end of a sliver of textile fibres, characterised in that it includes:
 – a first gripper (8) for gripping a portion of the sliver (2) which extends over a base plate (4),
 – a second gripper (22) which is movable between a waiting position and an operative position adjacent the first gripper, in which the second gripper (22) can grip the sliver (2) near the point where it has been gripped by the first gripper (8),
 – means for moving the second gripper (22) between its waiting position and its operative position and vice versa, so that the sliver is torn at a programmed level when the second gripper (22) is returned to its waiting position after gripping the sliver (2), and
 – a third gripper (36) for gripping the end of the sliver (2) which has previously been torn by the second gripper (22) and supplying it to an entrainment device.
2. A device according to Claim 1, characterised in that the first gripper (8) includes first and second arms (10, 11) articulated about respective axes (12) which are parallel to each other and to the base plate (4), and in that the plate (4) has a slot (18) through which the end portions of the arms (10, 11) extend.
3. A device according to Claim 2, characterised in that the first gripper (8) includes a third arm (14) parallel to the first arm (10) and connected thereto by a bridge element, the base plate (4) having a second slot (20) parallel to the first, in which an end portion of the third arm (14) extends.
4. A device according to Claim 3, characterised in that the second gripper (22) includes first and second jaws (24, 26) each of which has a pair of arms arranged in a fork-like configuration, in which the arms of the first jaw (22) extend between the first arm (10) and the third arm (14) of the first gripper (8) when the second gripper (22) is in its operative position.
5. A device according to Claim 4, characterised in that the second gripper (22) has means for closing it partially and completely and is carried by a slide (28) which is slidable on a guide upright (30) perpendicular to the base plate (4).
6. A device according to Claim 4, characterised in that the third gripper (36) includes a pair of plates (38) which are articulated to each other and are adapted to grip the portion (2a) of the sliver which extends between the two pairs of arms of the jaws (24, 26) of the second gripper (22).
7. A device according to Claim 6, characterised in that the third gripper (36) is carried by an arm (42) which is pivotable about an axis (44) parallel to the guide upright (30) of the second gripper (22).
8. A device according to Claim 7, characterised in that the arm (42) of the third gripper (36) is carried by a slide (46) which is slidable along a line perpendicular to the axis (44) about which the arm (42) pivots.

FIG. 1

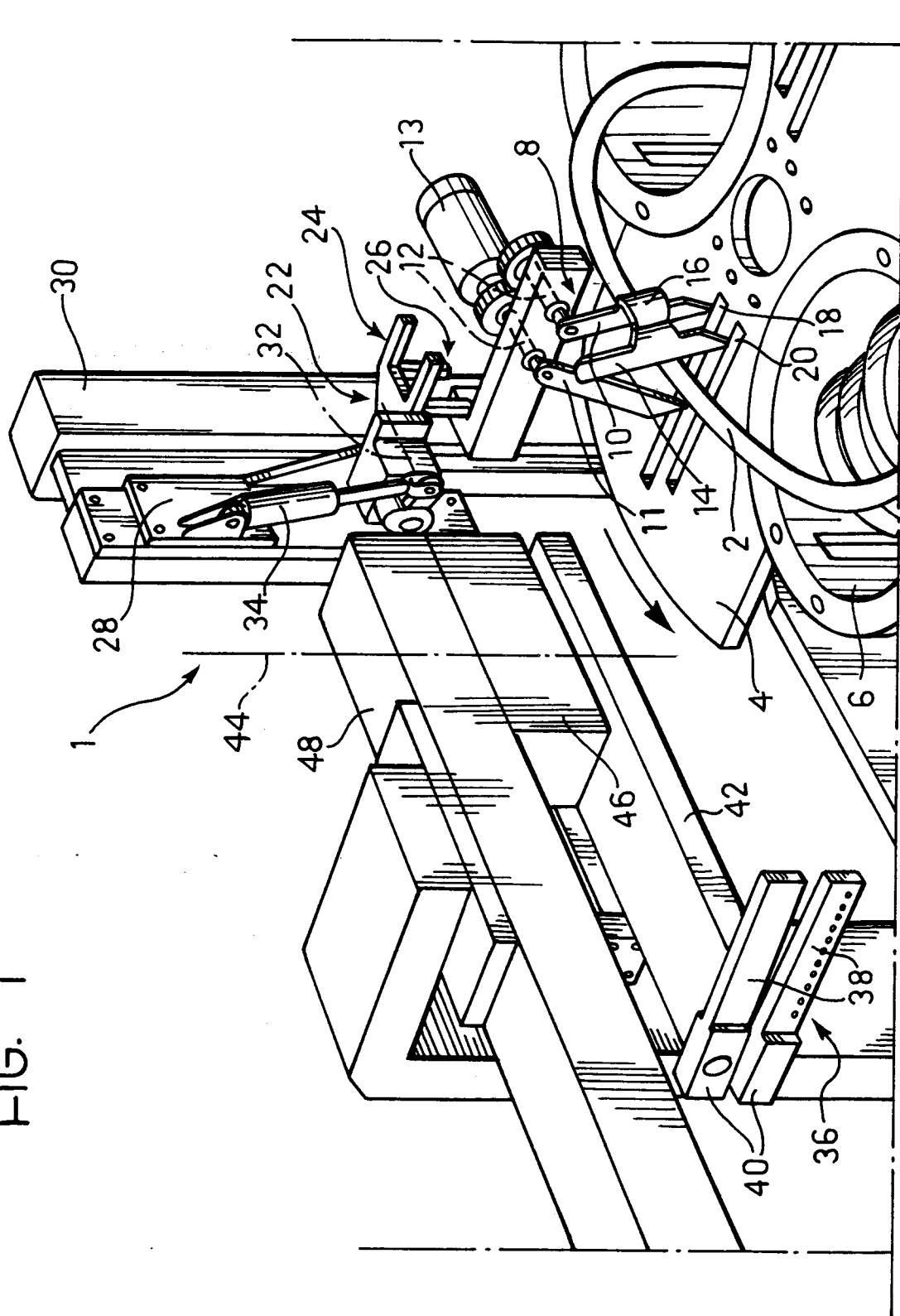

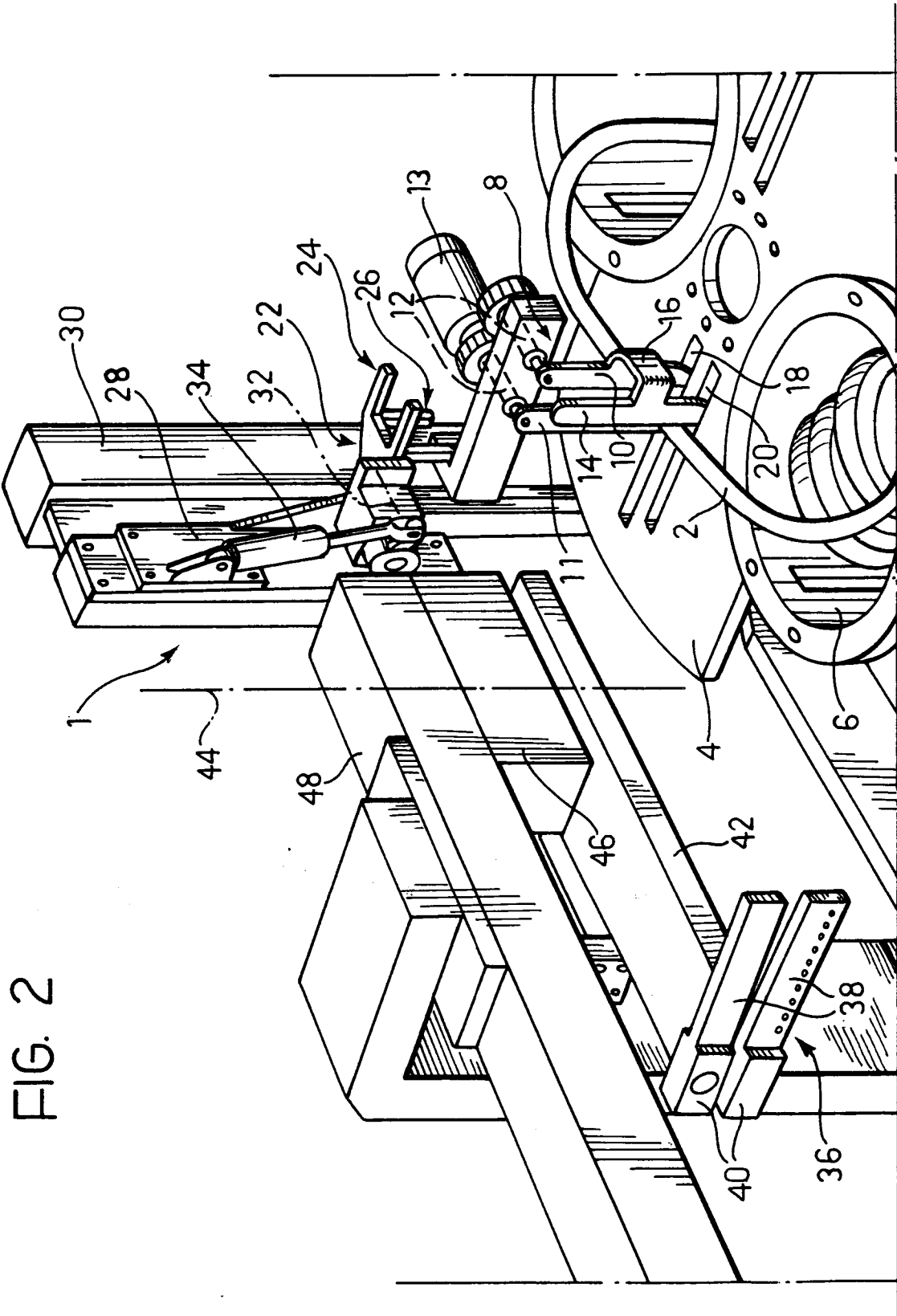
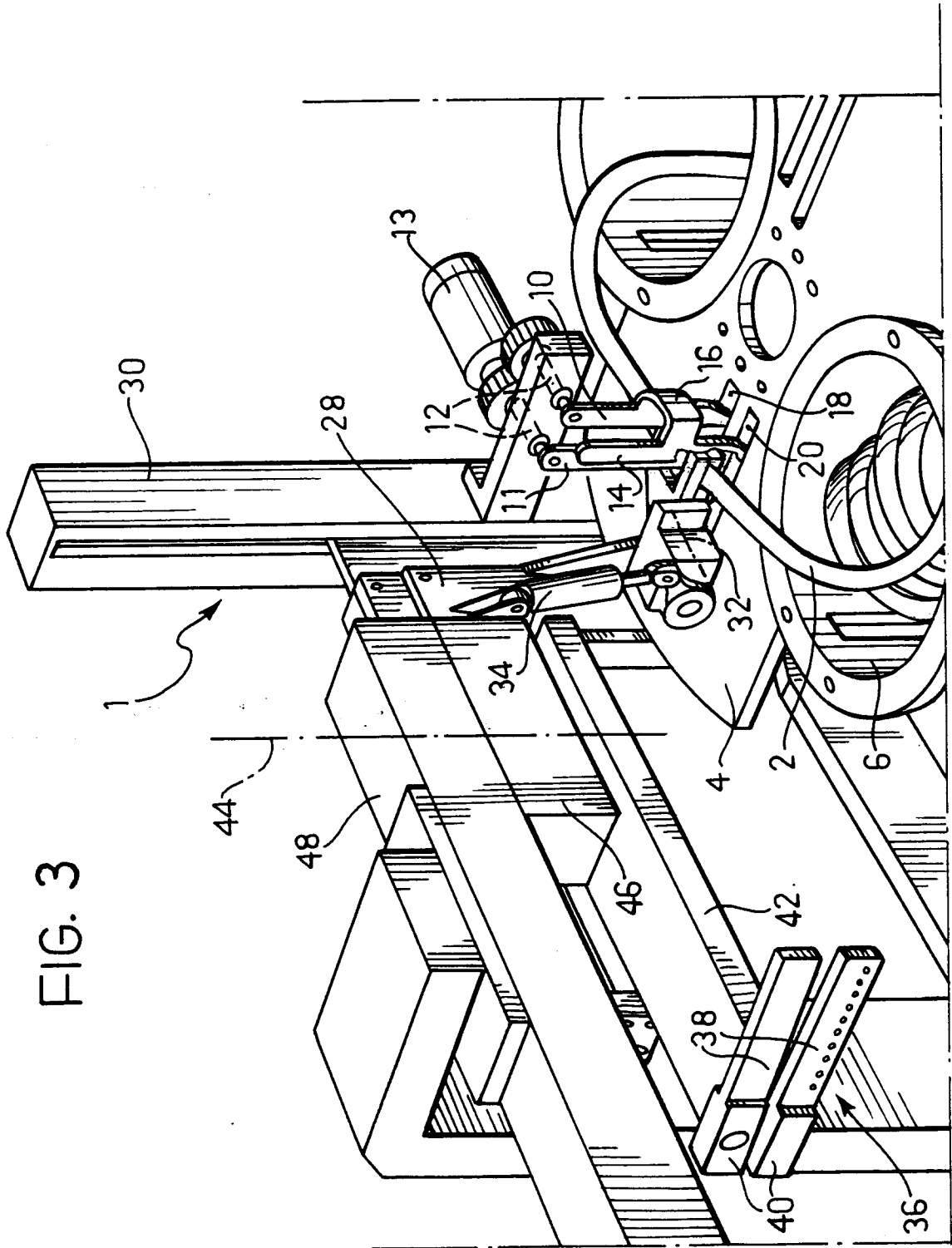

FIG. 2



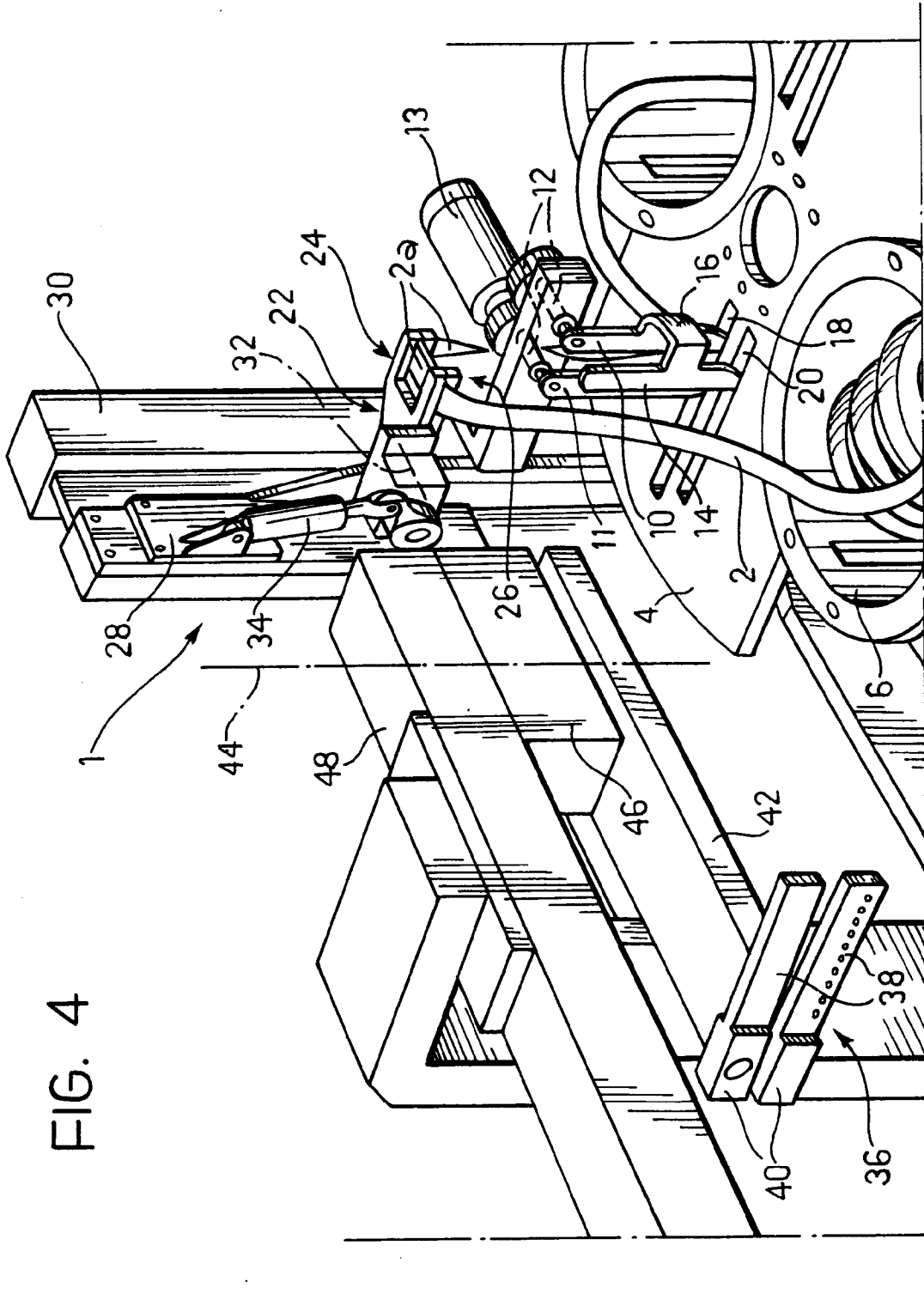
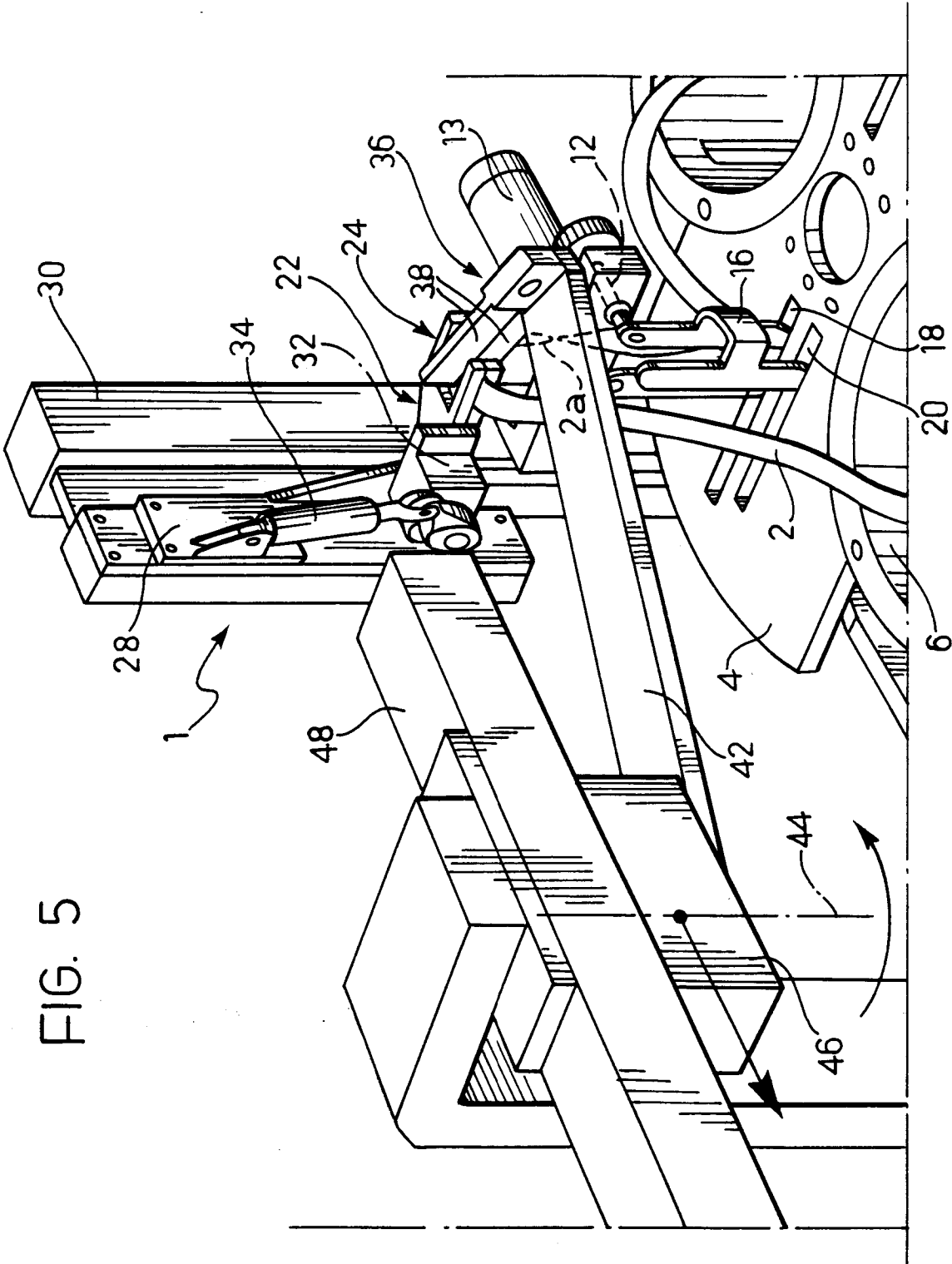

FIG. 4





European Patent
Office

EUROPEAN SEARCH REPORT

Application Number

EP 91 83 0562

DOCUMENTS CONSIDERED TO BE RELEVANT			
Category	Citation of document with indication, where appropriate, of relevant passages	Relevant to claim	CLASSIFICATION OF THE APPLICATION (Int. Cl.5)
A	EP-A-0 348 678 (SCAGLIA) * the whole document * ---	1	D01H5/00
A	EP-A-0 361 306 (K. K. TOYODA JIDOSHOKKI SEISAKUSHO ET AL.) * figures * ---	1	
A	GB-A-2 017 773 (BULLA) * the whole document * -----	1	
The present search report has been drawn up for all claims			TECHNICAL FIELDS SEARCHED (Int. Cl.5)
			D01H
Place of search THE HAGUE		Date of completion of the search 09 APRIL 1992	Examiner RAYBOULD B. D. J.
<p>CATEGORY OF CITED DOCUMENTS</p> <p>X : particularly relevant if taken alone Y : particularly relevant if combined with another document of the same category A : technological background O : non-written disclosure P : intermediate document</p> <p>T : theory or principle underlying the invention E : earlier patent document, but published on, or after the filing date D : document cited in the application L : document cited for other reasons & : member of the same patent family, corresponding document</p>			

EPO FORM 1503 03.82 (P0401)