



⑫ **EUROPEAN PATENT SPECIFICATION**

④⑤ Date of publication of patent specification :
21.06.95 Bulletin 95/25

⑤① Int. Cl.⁶ : **H05B 6/76, F24C 15/04**

②① Application number : **92302033.3**

②② Date of filing : **10.03.92**

⑤④ **Microwave oven.**

③⑩ Priority : **14.03.91 JP 74611/91**

④③ Date of publication of application :
16.09.92 Bulletin 92/38

④⑤ Publication of the grant of the patent :
21.06.95 Bulletin 95/25

⑥④ Designated Contracting States :
DE FR GB

⑤⑥ References cited :
EP-A- 0 131 324
EP-A- 0 406 728
FR-A- 2 484 397
PATENT ABSTRACTS OF JAPAN vol. 14, no.
65 (E-884) 6 February 1990 & JP-A-1 286 286
(MATSUSHITA ELECTRIC INDUSTRIEL CO.)
17 November 1989

⑤⑥ References cited :
PATENT ABSTRACTS OF JAPAN vol. 10, no.
345 (C-386)20 November 1986 20 November
1986 & JP-A-61 146 737 (MIE YUSHI KAKO
K.K.) 4 July 1986
WORLD PATENTS INDEX LATEST Section Ch,
Week 8750, Derwent Publications Ltd, London,
GB, Class a, AN 87352749 & JP-A-62 256 969
(MITSUBISHI DENKI K.K.)) November 1987

⑦③ Proprietor : **KABUSHIKI KAISHA TOSHIBA**
72, Horikawa-cho
Saiwai-ku
Kawasaki-shi Kanagawa-ken 210 (JP)

⑦② Inventor : **Wada, Masahiko, Nagoya Works,**
K.K. Toshiba
21, Yoshihara-cho 4-chome,
Nishi-ku
Nagoya (JP)

⑦④ Representative : **Freed, Arthur Woolf et al**
MARKS & CLERK,
57-60 Lincoln's Inn Fields
London WC2A 3LS (GB)

EP 0 503 899 B1

Note : Within nine months from the publication of the mention of the grant of the European patent, any person may give notice to the European Patent Office of opposition to the European patent granted. Notice of opposition shall be filed in a written reasoned statement. It shall not be deemed to have been filed until the opposition fee has been paid (Art. 99(1) European patent convention).

Description

This invention relates to an improvement of an electric wave leakage preventing structure for a door opening and closing a cooking chamber of microwave ovens.

Microwave ovens are generally provided with a viewing window provided in a door opening and closing a cooking chamber so that a user can look into the cooking chamber through it from the outside. The viewing window is provided with an inner barrier for electric wave shielding. The inner barrier comprises an electric wave shielding punched plate formed integrally with a frame of the door and having a number of small holes and a glass plate covering the punched plate.

In accordance with the above-described conventional construction, however, the dimension of each hole formed in the punched plate has a certain limitation from a standpoint of the electric wave leakage prevention and moreover, the number of the holes or the density of the holes also has certain limitation from the standpoint of the punching. Consequently, when the user looks into the cooking chamber, the punched plate unavoidably comes into sight, which prevents the user from looking into the cooking chamber. EP-A-0 131 327 discloses such a microwave oven.

The construction as shown in FIG. 7 has been proposed in order to overcome the above-described disadvantage. Referring to FIG. 7, a mesh conductor pattern 2 is formed on one side of a glass plate 1, thereby composing an inner barrier 3. The inner barrier 3 is mounted on the frame of a door. FR-A-2 484 397 discloses such a microwave oven.

In accordance with the construction shown in FIG. 7, however, the conductor pattern 2 is formed on the cooking chamber side of the glass plate 1. Accordingly, the user inadvertently hits a cooking pan or the like against the conductor pattern 2 such that it is damaged or cut off, resulting in reduction of the electric wave shielding capacity. Furthermore, a number of line portions 2a of the conductor pattern 2 are projected in an edge portion of the glass plate 1. These projected line portions 2a disadvantageously act as antennas, resulting in further reduction of the electric wave shielding capacity.

Therefore, an object of the present invention is to provide a microwave oven wherein visibility of the cooking chamber interior can be improved while sufficient electric wave shielding capacity can be obtained.

According to one aspect of the present invention, there is provided a microwave oven wherein an inner barrier for electric wave shielding is provided on a main frame of a door mounted for opening and closing a cooking chamber, the inner barrier comprising a transparent base plate and a mesh conductor pattern

formed on one side of the base plate, characterized in that the mesh conductor pattern is formed on a counter cooking chamber side of the base plate, the conductor pattern including a portion disposed along an edge of the base plate, the portion of the conductor pattern having a line width larger than the other portion of the base plate, the portion of the conductor pattern being in contact with the main frame of the door.

According to another aspect of the invention, there is provided a microwave oven wherein an inner barrier for electric wave shielding is provided on a main frame of a door mounted for opening and closing a cooking chamber, the inner barrier comprising a transparent base plate and a mesh conductor pattern formed on one side of the base plate, characterized in that the conductor pattern is formed on a counter cooking chamber side of the base plate, the conductor pattern including a frame-shaped conductor portion disposed along the peripheral edge of the base plate and line conductor portions formed into the shape of a mesh and each having two ends connected to the frame-shaped conductor portion, the frame-shaped conductor portion being in contact with the main frame of the door.

It is preferable that the portion of the conductor pattern in contact with the frame have a thickness larger than the other portion thereof in each above-described construction.

It is also preferable that the conductor pattern be formed either by a method of electroless plating or by screen printing a conductive paint.

It is further preferable that the conductor pattern be formed into the shape of a lattice.

It is preferred that the main frame has a frame, a contact plate and a choke groove, an outer barrier is mounted on the front side of the frame, a door sash is mounted on the outer periphery of the frame, and the portion of the conductor pattern is in contact with the frame of the door.

The invention will be described, merely by way of example, with reference to the accompanying drawings in which:

FIG. 1 is a partial plan view of a conductor pattern employed in a microwave oven of a first embodiment according to the present invention;

FIG. 2 is a perspective view of the microwave oven;

FIG. 3 is a partial sectional view of a door for opening and closing a cooking chamber in the microwave oven;

FIG. 4 is a plan view of the conductor pattern;

FIG. 5 is a view similar to FIG. 1 illustrating the conductor pattern in the microwave oven of a second embodiment;

FIG. 6 is a partial sectional view of an inner barrier employed in the microwave oven of a third embodiment; and

FIG. 7 is a view similar to FIG. 1 showing a prior art construction.

A first embodiment of the invention will now be described with reference to FIGS. 1 through 4. Referring first to FIG. 2, a cooking chamber 12 is defined in an outer casing 11 of a microwave oven according to the invention. The cooking chamber 12 has a front opening which is opened and closed by a door 13. An operation panel 14 is provided on the right-hand front side of the outer casing 11. The operation panel 14 includes a display section 15 and various switches 16.

A machine compartment (not shown) is defined on the right of the cooking chamber 12 in the outer casing 11. A magnetron (not shown) and the like are provided in the machine compartment. Upon oscillation of the magnetron, high frequency waves are propagated into the cooking chamber 12 so as to be irradiated onto food (not shown) contained in it, thereby heating the food for the range cooking.

A drive shaft 17 is projected through the bottom of the cooking chamber 12. The drive shaft 17 is driven by an electric motor (not shown). A turntable (not shown) on which the food to be cooked is placed is coupled to the drive shaft 17 so as to be turned. A heater 18 for the oven cooking is mounted on the ceiling of the cooking chamber 12.

The door 13 includes a generally rectangular viewing window 19 through which the user can look into the cooking chamber 12. Describing the construction of the door 13 in detail with reference to FIGS. 1, 3 and 4, the door 13 comprises a metal main frame 51 and a transparent glass outer barrier 21 mounted on the front face of the main frame 51, as shown in FIG. 3. The main frame 51 comprises a main portion 20 and a contact plate 23. In this case, the frame 20 has a vertical flange 22 extending over the entire inner periphery thereof inside the outer barrier 21. Another flange 24 provided on a contact plate 23 is welded to the flange 22 of the main portion 20 so that the contact plate 23 is provided integrally with the frame 20. A space defined by the main portion 20 and the contact plate 23 serves as a choke groove 25. The door 13 is thus assembled so that the frame 51 has the contact plate 23 and the choke groove 25. A door cover 26 is provided in an opening defined by the main portion 20 and the outer periphery of the contact plate 23. A door sash 27 is mounted on the outer periphery of the main portion 20.

An inner barrier 28 is bonded to the rear face of the flange 24 of the contact plate 23, for example, by a silicon resin adhesive 29. The inner barrier 28 comprises a transparent base plate such as a transparent glass plate 30 and a mesh conductor pattern 31 (see FIGS. 1 and 4) formed on a counter cooking chamber side of the glass plate 30 or the left-hand side of the glass plate 30 as viewed in FIG. 3. The conductor pattern 31 is formed, for example, by depositing copper on the surface of the glass plate 30 by way of elec-

troless plating or by screen printing an electrically conductive paint such as pasted copper on the surface of the glass plate 30. In the above-mentioned electroless plating, metal ions such as copper ions are stuck on the surface of the previously catalyzed glass plate 30 by a predetermined action of autocatalysis reduction.

The conductor pattern 31 has the thickness of about 0.2μ . As shown in FIGS. 1 and 4, the conductor pattern 31 comprises a frame-shaped conductor portion 33 disposed along the peripheral edge of the glass plate 30 and line conductor portions 32 each having both ends connected to the frame-shaped conductor portion 33 and formed into the shape of a mesh. Each line conductor portion 32 has the line width A of about 40μ . The space B between the center line of each line conductor portion 32 and that of its adjacent line conductor portion 32 is set to about 140μ . The frame-shaped conductor portion 33 has the line width C of about 80μ . Thus, the line width C of the frame-shaped conductor portion 33 is larger than the line width A of each line conductor portion 32. The frame-shaped conductor portion 33 of the conductor pattern 31 is in direct contact with the rear face of the flange 24 of the contact plate 23 and in other words, the silicon resin adhesive 29 is applied between the outer periphery of the glass plate 30 and the flange 24. The frame-shaped conductor portion 33 of the conductor pattern 31 is thus brought into contact with the main frame 51.

The operation of the microwave oven will now be described. The magnetron is driven so that the high frequency waves are irradiated onto the food in the cooking chamber 12, thereby executing the range cooking. Although a part of the high frequency waves propagated into the cooking chamber 12 is irradiated to the door 13 side, the energy of this part of high frequency waves is attenuated by the contact plate 23, the choke groove 25, a front panel portion 11a of the outer casing 11 and the like in turn. Consequently, the high frequency waves can be prevented from leaking out of the cooking chamber 12. Furthermore, the high frequency waves irradiated to the viewing window 19 side is shielded by the conductor pattern 31 of the inner barrier 28. The high frequency waves reaching the conductor pattern 31 is shielded by the contact of the main portion 20 with the frame-shaped conductor portion 33 of the conductor pattern 31.

In accordance with the above-described embodiment, the mesh conductor pattern 31 is formed on the glass plate 30 by way of the electroless plating or the screen printing. This eliminates the restriction in punching the punched plate and increases the number of holes formed in the punched plate, resulting in improvement of the visibility of the cooking chamber interior. Furthermore, since the conductor pattern 31 is formed on the counter cooking chamber side of the glass plate 30, the user can be prevented from hitting

the cooking pan or the like against the conductor pattern 31. Consequently, the conductor pattern 31 can be prevented from being damaged or cut off and the electric wave shielding capacity of the conductor pattern 31 can be prevented from being reduced.

Furthermore, the conductor pattern 31 includes the frame-shaped conductor portion 33 and the line conductor portions 32 each having both ends connected to the frame-shaped conductor portion 33. The frame-shaped conductor portion 33 of the conductor pattern 31 is in contact with the main frame 51 of the door 13. Contact areas of the main frame 51 and the conductor pattern 31 are thus increased as compared with the prior art construction shown in FIG. 7, resulting in secure connection between them. Consequently, since the line conductor portions 32 are reliably connected to the main frame 51, they are not projected in the edge portion of the glass plate 30 in contrast to the prior art construction as shown in FIG. 7. The end portions of the line conductor portions 32 can be prevented from acting as antennas and accordingly, the electric wave shielding capacity can be prevented from being reduced.

Although the conductor pattern 31 includes the frame-shaped conductor portion 33 disposed along the peripheral edge of the glass plate 30 in the foregoing embodiment, the conductor pattern may be arranged as shown as a second embodiment in FIG. 5. In FIG. 5, the line width D of the portion of each line conductor portion 34 disposed at the edge portion of the glass plate 30 is larger than the line width A of the other portion of the conductor pattern 31 such that each line conductor portion 34 is not continuous with its adjacent one. The wider portion of each line conductor portion 34 is in contact with the main portion 20. Accordingly, the same effect can be achieved in the second embodiment as in the first embodiment.

In comparison of the first and second embodiments, it can be considered that the frame-shaped conductor portion 33 of the conductor pattern 31 in the first embodiment is formed by further widening each line conductor portion 34 in the second embodiment such that each line conductor portion 34 becomes continuous with its adjacent one. Accordingly, it can be considered that the conductor pattern 31 in the first embodiment has the arrangement that the width of the portion of the conductor pattern 31 disposed at the edge portion of the glass plate 30 is rendered larger than that in the other portion thereof.

Although the glass plate 30 is employed as the transparent base plate in the foregoing embodiments, a plastic transparent plate may be employed therefor.

FIG. 6 shows a third embodiment of the invention. The difference between the third embodiment and each foregoing embodiment will be described. FIG. 6 illustrates an enlarged section of the edge of an inner barrier 35 employed instead of the inner barrier 28.

The inner barrier 35 comprises a glass plate 36 and a conductor pattern 37 formed on one side of the glass plate 36. The conductor pattern 37 includes a portion 38 brought into contact with the main portion 20. The thickness E of the portion 38 is larger than the thickness F of the other portion 39 of the conductor pattern 37. The portion 38 corresponds to the frame-shaped conductor portion 33 in the first embodiment and to each line conductor portion 34 in the second embodiment. The portion 39 of the conductor pattern 37 corresponds to each line conductor portion 32 in the first and second embodiments. The thickness E of the portion 38 is set to about 0.4μ and the thickness F of the portion 39 is set to about 0.2μ .

The same effect can be achieved in the third embodiment as in the first embodiment. In particular, the conductor pattern 37 is brought into contact with the main portion 20 when the inner barrier 35 is mounted on the main portion 20. There is a possibility that the conductor pattern 37 may be peeled off or damaged when it is brought into contact with the frame 20. In the third embodiment, however, the thickness E of the portion 38 of the conductor pattern 37 brought into contact with the main portion 20 is larger than the thickness F of the other portion 39 thereof. Consequently, the portion 38 of the conductor pattern 37 can be prevented from being peeled off or damaged since the durability of the portion 38 brought into contact with the main portion 20 is increased.

The foregoing disclosure and drawings are merely illustrative of the principles of the present invention and are not to be interpreted in a limiting sense. The only limitation is to be determined from the scope of the appended claims.

Claims

1. A microwave oven wherein an inner barrier (28) for electric wave shielding is provided on a main frame (51) of a door (13) mounted for opening and closing a cooking chamber (12), the inner barrier (28) comprising a transparent base plate (30) and a mesh conductor pattern (31) formed on one side of the base plate (30), characterized in that the mesh conductor pattern (31) is formed on a counter cooking chamber side of the base plate (30), the conductor pattern (31) including a portion (33, 34) disposed along an edge of the base plate (30), the portion (33, 34) of the conductor pattern (31) having a line width larger than the other portion of the base plate (30), the portion (33,34) of the conductor pattern (31) being in contact with the main frame (51) of the door (13).
2. A microwave oven wherein an inner barrier (28) for electric wave shielding is provided on a main frame (51) of a door (13) mounted for opening

and closing a cooking chamber (12), the inner barrier (28) comprising a transparent base plate (30) and a mesh conductor pattern (31) formed on one side of the base plate (30), characterized in that the conductor pattern (31) is formed on a counter cooking chamber side of the base plate (30), the conductor pattern (31) including a frame-shaped conductor portion (33) disposed along the peripheral edge of the base plate (30) and line conductor portions (32) formed into the shape of a mesh and each having two ends connected to the frame-shaped conductor portion (33), the frame-shaped conductor portion (33) being in contact with the main frame (51) of the door (13).

3. A microwave oven according to claim 1 or claim 2, characterized in that the portion (33,34) of the conductor pattern (31) in contact with the main frame (51) has a thickness larger than the other portion thereof.

4. A microwave oven according to claim 1 or claim 2, characterized in that the conductor pattern (31) is formed by a method of electroless plating.

5. A microwave oven according to claim 1 or claim 2, characterized in that the conductor pattern (31) is formed by screen printing a conductive paint.

6. A microwave oven according to claim 1 or claim 2, characterized in that the conductor pattern (31) is formed into the shape of a lattice.

7. A microwave oven according to claim 1, characterized in that the main frame (51) has a frame (20), a contact plate (22) and a choke groove (25), an outer barrier (21) is mounted on the front side of the frame (20), a door sash (27) is mounted on the outer periphery of the frame (20), and the portion (33) of the conductor pattern (31) is in contact with the frame (20) of the door (13).

Patentansprüche

1. Mikrowellenherd, bei dem eine Innenisolierung (28) für die Abschirmung der elektrischen Wellen am Hauptrahmen (51) einer Tür (13) angebracht ist, die für das Öffnen und Schließen einer Kochkammer (12) montiert ist, wobei die Innenisolierung (28) aufweist: eine transparente Grundplatte (30) und ein Netzleiterraster (31), das auf einer Seite der Grundplatte (30) gebildet wird, dadurch gekennzeichnet, daß das Netzleiterraster (31) auf der der Kochkammer gegenüberliegenden Seite der Grundplatte (30) gebildet wird, wobei das Leiterraster (31) einen Abschnitt (33, 34) um-

faßt, der entlang eines Randes der Grundplatte (30) angeordnet ist, wobei der Abschnitt (33, 34) des Leiterrasters (31) eine Linienbreite aufweist, die größer ist als beim anderen Abschnitt der Grundplatte (30), und wobei der Abschnitt (33,34) des Leiterrasters (31) mit dem Hauptrahmen (51) der Tür (13) in Berührung ist.

2. Mikrowellenherd, bei dem eine Innenisolierung (28) für die Abschirmung der elektrischen Wellen am Hauptrahmen (51) einer Tür (13) angebracht ist, die für das Öffnen und Schließen einer Kochkammer (12) montiert ist, wobei die Innenisolierung (28) aufweist: eine transparente Grundplatte (30) und ein Netzleiterraster (31), das auf einer Seite der Grundplatte (30) gebildet wird, dadurch gekennzeichnet, daß das Leiterraster (31) auf der der Kochkammer gegenüberliegenden Seite der Grundplatte (30) gebildet wird, wobei das Leiterraster (31) umfaßt: einen rahmenförmigen Leiterabschnitt (33), der entlang des peripheren Randes der Grundplatte (30) angeordnet ist; und linienförmige Leiterabschnitte (32), die in der Form eines Netzes ausgebildet sind, und die jeweils zwei Enden aufweisen, die mit dem rahmenförmigen Leiterabschnitt (33) verbunden sind, wobei der rahmenförmige Leiterabschnitt (33) mit dem Hauptrahmen (51) der Tür (13) in Berührung ist.

3. Mikrowellenherd nach Anspruch 1 oder 2, dadurch gekennzeichnet, daß der Abschnitt (33, 34) des Leiterrasters (31), der mit dem Hauptrahmen (51) in Berührung ist, eine Dicke aufweist, die größer ist als beim anderen Abschnitt.

4. Mikrowellenherd nach Anspruch 1 oder 2, dadurch gekennzeichnet, daß das Leiterraster (31) mittels des Verfahrens des stromlosen Galvanisierens gebildet wird.

5. Mikrowellenherd nach Anspruch 1 oder 2, dadurch gekennzeichnet, daß das Leiterraster (31) durch Siebaufdruck einer leitfähigen Farbe gebildet wird.

6. Mikrowellenherd nach Anspruch 1 oder 2, dadurch gekennzeichnet, daß das Leiterraster (31) in der Form eines Gitters gebildet wird.

7. Mikrowellenherd nach Anspruch 1, dadurch gekennzeichnet, daß der Hauptrahmen (51) einen Rahmen (20), eine Kontaktplatte (22) und eine Drosselrinne (25) aufweist; daß eine Außenisolierung (21) an der Vorderseite des Rahmens (20) angebracht ist; daß ein Türrahmen (27) an der äußeren Peripherie des Rahmens (20) angebracht ist; und daß der Abschnitt (33) des Leiterrasters

(31) mit dem Rahmen (20) der Tür (13) in Berührung ist.

Revendications

1. Four à micro-ondes dans lequel une barrière interne (28) de protection contre les ondes électriques est agencée sur un cadre principal (51) d'une porte (13), servant à l'ouverture et à la fermeture d'une chambre de cuisson (12), la barrière interne (28) comprenant une plaque de base transparente (30) et un motif conducteur à mailles (31) formé sur un côté de la plaque de base (30), caractérisé en ce que le motif conducteur à mailles (31) est formé sur un côté opposé à la chambre de cuisson de la plaque de base (30), le motif conducteur (31) englobant une partie (33, 34) agencée le long d'un bord de la plaque de base (30), et la partie (33, 34) du motif conducteur (31) ayant une largeur de ligne supérieure à celle de l'autre partie de la plaque de base (30), la partie (33, 34) du motif conducteur (31) étant en contact avec le cadre principal (51) de la porte (13). 5
2. Four à micro-ondes, dans lequel une barrière interne (28) de protection contre les ondes électriques, est agencée sur un cadre principal (51) d'une porte (13) servant à l'ouverture et à la fermeture d'une chambre de cuisson (12), la barrière interne (28) comprenant une plaque de base transparente (30) et un motif conducteur à mailles (31) formé sur un côté de la plaque de base (30), caractérisé en ce que le motif conducteur (31) est formé sur un côté opposé à la chambre de cuisson de la plaque de base (30), le motif conducteur (31) englobant une partie conductrice en forme de cadre (33), agencée le long d'un bord périphérique de la plaque de base (30), et des parties conductrices de ligne (32) en forme d'une maille, comportant chacune deux extrémités connectées à la partie conductrice en forme de cadre (33), la partie conductrice en forme de cadre (33) étant en contact avec le cadre principal (51) de la porte (13). 10
3. Four à micro-ondes selon les revendications 1 ou 2, caractérisé en ce que la partie (33, 34) du motif conducteur (31) en contact avec le cadre principal (51) a une épaisseur supérieure à l'autre partie correspondante. 15
4. Four à micro-ondes selon les revendications 1 ou 2, caractérisé en ce que le motif conducteur (31) est formé par un procédé de placage sans courant. 20

5. Four à micro-ondes selon les revendications 1 ou 2, caractérisé en ce que le motif conducteur (31) est formé par sérigraphie d'une peinture conductrice. 25
6. Four à micro-ondes selon les revendications 1 ou 2, caractérisé en ce que le motif conducteur (31) a la forme d'un treillis. 30
7. Four à micro-ondes selon la revendication 1, caractérisé en ce que le cadre principal (51) comporte un cadre (20), une plaque de contact (22) et une rainure d'étranglement (25), une barrière externe (21) étant montée sur le côté frontal du cadre (20), un châssis de porte (27) étant monté sur la périphérie externe du cadre (20) et la partie (33) du motif conducteur (31) étant en contact avec le cadre (20) de la porte (13). 35

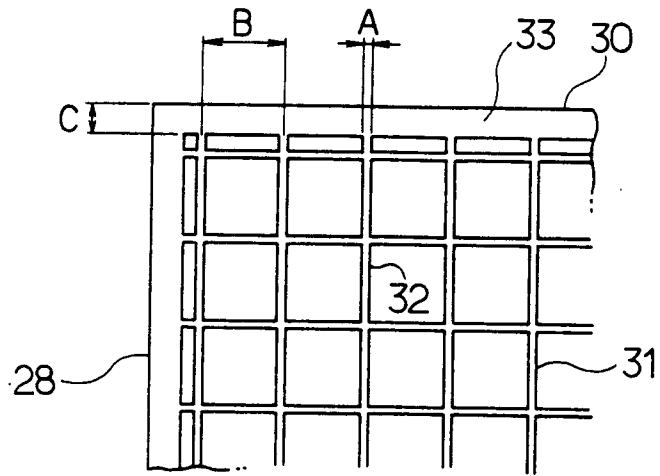

FIG. 1

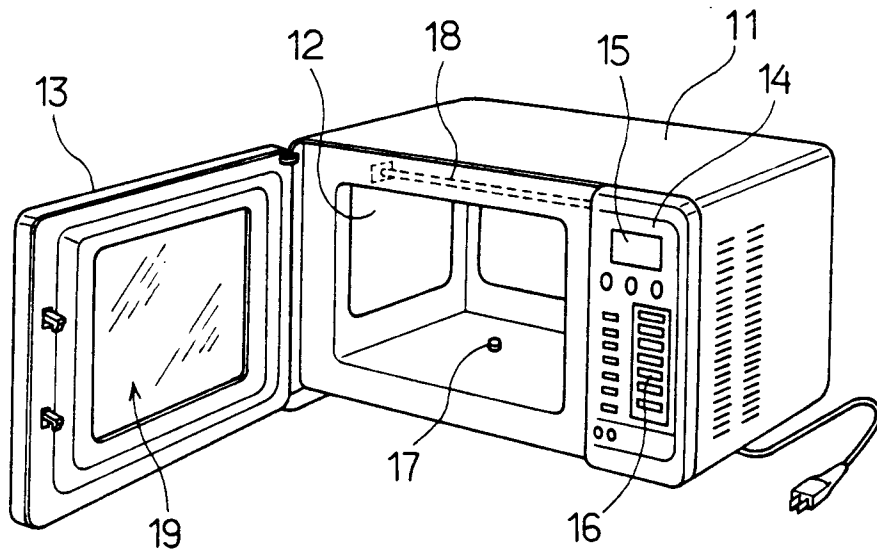

FIG. 2

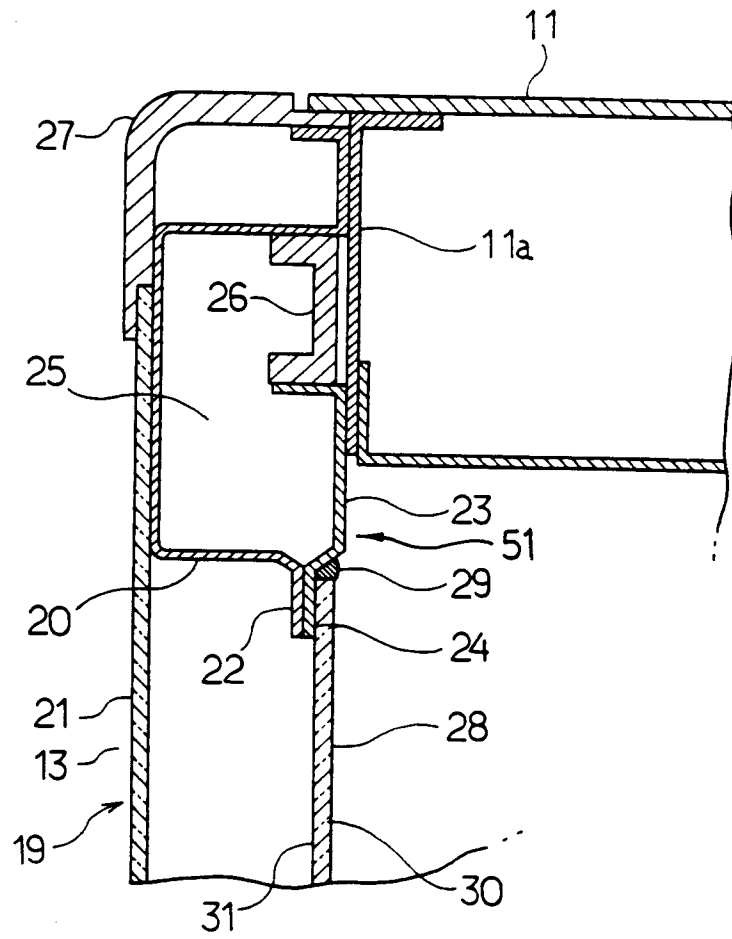

FIG. 3

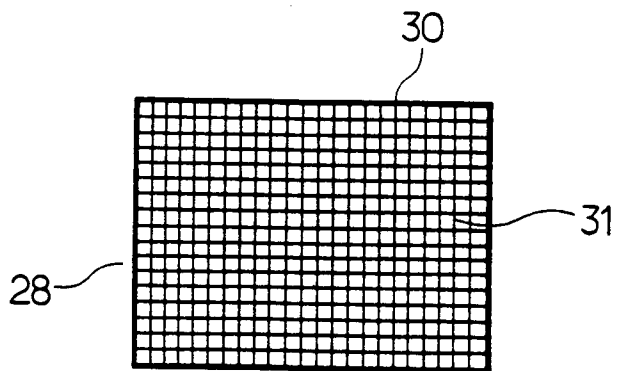

FIG. 4

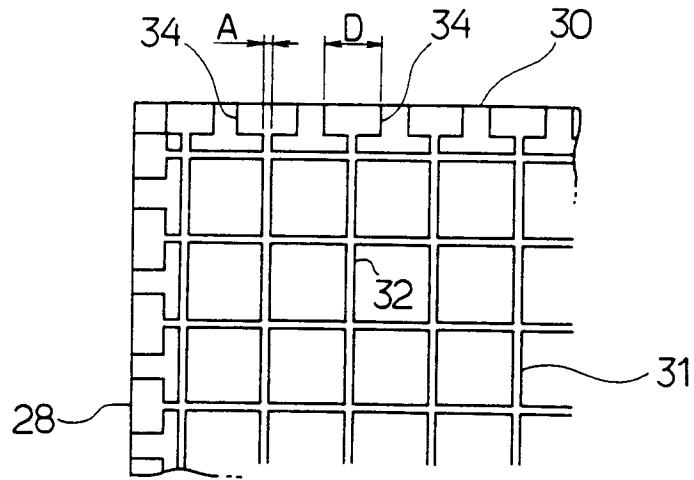

FIG. 5

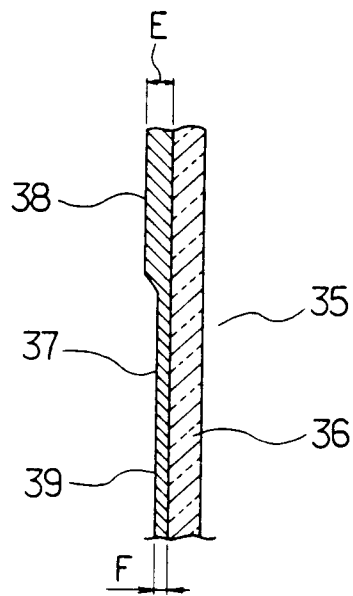

FIG. 6

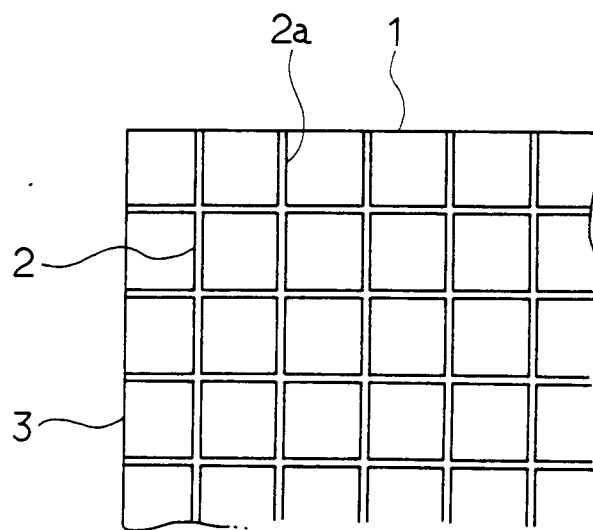

FIG.7 (PRIOR ART)