



EUROPEAN PATENT APPLICATION

Application number: **92830188.6**

Int. Cl.⁵: **E05D 11/08**

Date of filing: **16.04.92**

Priority: **22.04.91 IT BS910042 U**
20.02.92 IT BS920019 U

Inventor: **Comaglio, Aldo**
3, Via Roccolino
I-25085 Gavardo (Brescia) (IT)

Date of publication of application:
28.10.92 Bulletin 92/44

Representative: **Manzoni, Alessandro**
MANZONI & MANZONI - UFFICIO
INTERNAZIONALE BREVETTI P.le Arnaldo n.
2
I-25121 Brescia (IT)

Designated Contracting States:
AT BE CH DE DK ES FR GB GR IT LI LU NL PT
SE

Applicant: **COM.A.C. di COMAGLIO ALDO**
3, Via Roccolino
I-25085 Gavardo (Brescia) (IT)

Door and window stop for any partially or totally open position.

The invention relates to a door and window stop device for any partially or totally open position which comprises a rotating element (15) splined to the rotating component of the hinge, a striker plate (16) and an intermediate friction joint (17) for the coupling of said rotating element (15) and striker plate (16). The striker plate (16) is fixed to the case of the frame or to the stationary component of the hinge, and the intermediate friction joint (17) couples with said striker plate (16) without rotating in order to broke the door or window movements.

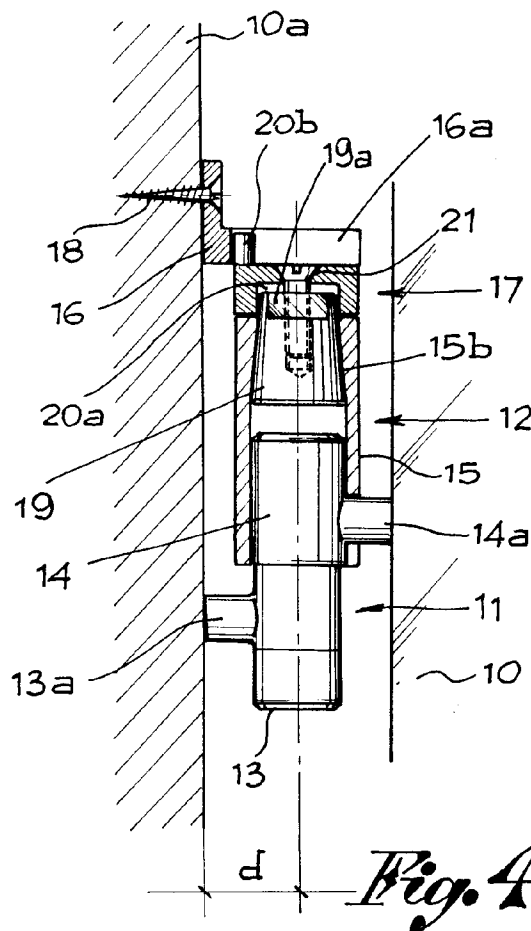

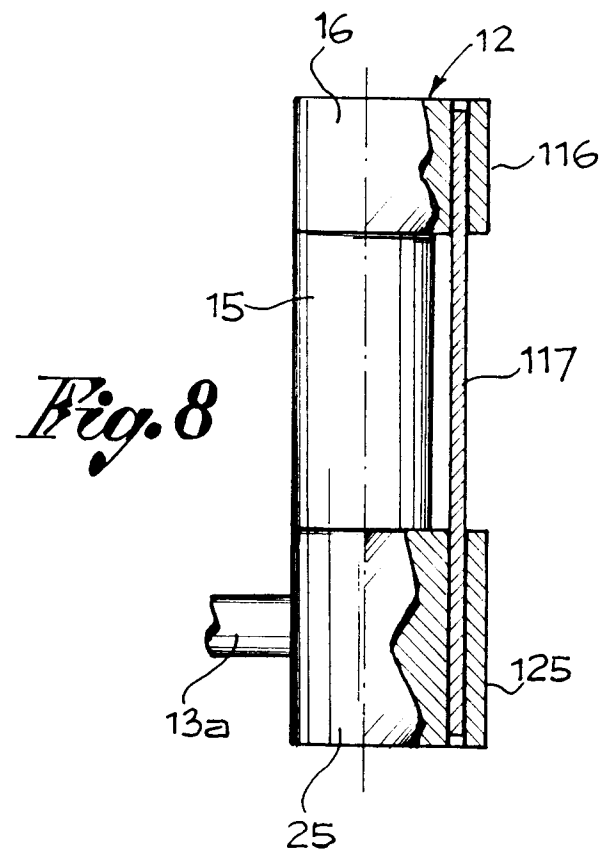

The present invention refers to fittings for frames and to be more particular to a stop device for doors and windows when partially or totally open.

A stop device which can be fitted to at least a hinge of a door or window and works as an adjustable brake to stop the frame in any partially or totally open position has already been proposed. Such a device is not suitable for a good fitting to all types of door hinges.

The space between the hinge and the jamb or case to which the stop is anchored often varies considerably from construction to construction of a door and window frame. The problem to solve is thus to produce a stop which can be adapted to any installation condition.

The present invention aims to solve this problem through a new and original manufacture and combination of the components of the stop device and especially due to a running and self-adjustable fit between a part of the stop device designed to rotate with the hinge and a striker plate to be fixed to the case of the frame. Such a running fit is foreseen in order to allow for a positioning of the rotating part of the device in an orthogonal direction to the surface of the case to which the striker plate is fitted, thus permitting a self-adjustment of the device to any existing space between the hinge and the case and the device therefore becoming universal.

The here proposed stop device is substantially in accordance with claim 1.

An advantageous variant of the embodiment of the proposed device is the extreme simplicity of construction and that there is no component which needs to be fixed apart from the hinge and thus is easy to be applied even without removing the door from the hinges. The stop device can therefore be fitted and constrained exclusively to the hinges and can even be fixed and used where the space between the hinge and the case is narrow and difficult to get to.

The attached drawings illustrate examples of embodiments of the invention and more precisely:

Fig. 1 is part of a door with a hinge having a device;

Fig. 2 is a prospective exploded view of the device in accordance with the invention;

Fig. 3 is a prospective view of the assembled device fitted to the hinge;

Fig. 4 is an axial section view of the device;

Fig. 5 is part of a door with a hinge having a stop device constituting a variant of the invention;

Fig. 6 is an exploded prospective view of the variant of the device;

Fig. 7 is an axial section view of the device in Fig. 6 when assembled;

Fig. 8 is a partial section external view of the device in Fig. 7; and

Fig. 9 is a transversal section view on the arrows IX-IX in Fig. 7.

Said drawings show part of a door (10) with a relative hinge (11) to which the stop device (12) is fitted in accordance with the invention.

The hinge (11) usually has a stationary component (13) which is applied through a shank (13a) to the case (10a) of the frame and a rotating component (14) which is rotatably applied to the stationary one and constrained to the door (10) for its opening and closing movements through a lateral shank (14a).

The embodiment in Figs. 1-4 show the stop device (12) having a rotating element (15), a striker plate (16) and an intermediate friction joint (17) connecting the rotating element (15) to the fixed one (16).

The rotating element (15), in the shape of a sleeve, is splined to and simultaneously rotates with the rotating element (14) of the hinge. It is coaxially assembled on said hinge component and has one lateral slit (15a) which couples with its shank (14a). The rotating element (15) has an internal cone-shaped slot (15b) at a different height to the one which holds the rotating component of the hinge.

The striker plate (16) in the form of a disk has a slit (16a) which is either radially open or closed, that is to say a slot, and has a tab (16b) on its back with holes (16c) for screws (18) to fix the element itself to the case (10a) of the frame.

The intermediate friction joint (17) is made up of a cone-shaped body (19), a splining ring (20) and an adjustable blocking screw (21).

The cone-shaped body (19) is completely inserted into the cone-shaped slot (15b) of the rotating element (15) and protrudes from the latter with a tapered end which has a polygonal area (19a) or is fitted with a splining tab.

The polygonal area (19a), or the tab, couples to a corresponding seat (20a) formed on the base of the splining ring (20) so that the two elements can rotate in respect to each other. The blocking screw (21) axially crosses the splining ring (20) and screws in a hole (19b) formed in the cone-shaped body (19). The screw (21) is thus used to axially constrain the cone-shaped body (19) to the splining ring (20).

Furthermore, seeing that the splining ring (20) rests on the rotating element (15), it is possible to adjust the coupling pressure between said body and the cone-shaped slot (15b) into which it is inserted by tightening or loosening the screw (21) in relation to the bottom. It is therefore possible to adjust the friction level, that is to say of stopping, but always giving the element (15) the possibility of rotating with the hinge component (14) and relatively to the cone-shaped body (19) and to the splining ring (20) which remain stationary.

The splining ring (20) has in fact a shank on the opposite surface to the one coupled with the cone-shaped body (19). Said shank is inserted in the slot (16a) of the striker plate (16) fitted to the case (10a) in order to prevent the rotation of the ring itself.

Figs. 3 and 4 show the coupling of various elements and how the device can prevent the rotation of the door due to the friction developed by the cone-shaped body (17) in the rotating element (15). It can also be appreciated how the coupling of the shank (20b) of the splining ring (20) with the slot (16a) of the fixed element (16) allows for the assembling and use of the device on the hinge whatever the space (d) between the case (10a) and the axis of the hinge itself may be.

The variant illustrated in Figs. 5 and 9, the equivalent elements and/or components of which have the same reference numbers, has a striker plate (16) which is not constrained to the case but an anchorage element (25) is added.

Thus, the rotating element (15) in the shape of a sleeve, is splined and simultaneously rotates with the rotating component (14) of the hinge and completely delimits a cone-shaped slot (15b) at a different height to the one holding the rotating component of the hinge.

The anchorage element (25) is in the form of a cap placed at the end of the rotating element (15).

It is fitted to the stationary element (13) of the hinge (11) in order to become splined seeing that the anchorage element has a lateral slit (25a) which couples with the lateral shank (13a) of said component (13) of the hinge.

The anchorage element (25) and the striker plate (16) are on the axis and on opposite ends of the rotating element (15).

Each one has a lateral protrudance (125, 116) which respectively have an opening (125a, 116a). The anchorage element (25) and the striker plate (16) are joined to each other through a blade (117) inserted and blocked in the openings (125a, 116a) and extend from one side of the rotating element (15). The two elements (125, 116) are thus integrated to each other and are both fixed to the stationary component (13) of the hinge whilst the rotating element (15) is fixed and can rotate with the movable component (14) of the hinge.

The joining blade (117) can be an element by itself and can be reproduced as shown in the drawing even if this does not exclude that the blade can be integrally formed with one of the two elements (125 and 116) and engage in an opening formed in the other element.

The friction joint (17) is the same as the one described in relation to Figs. 1, 4 and therefore has a cone-shaped body (19) which is inserted in the cone-shaped slot (15b) of the rotating element (15) and protrudes from the latter with a tapered end which has a polygonal area (19a) or is fitted with a splining tab.

The polygonal area (19a), or the tab, couples to a corresponding seat (20a) formed at the base of the striker plate (16), and the blocking screw (21) axially crosses said element and screws in a hole (19b)

formed in the cone-shaped body (19). It is possible to adjust the coupling pressure between the cone-shaped body (19) and the cone-shaped slot (15b) into which it is inserted by tightening or loosening the screw (21) in relation to the bottom. It is therefore possible to adjust the friction level, that is to say of stopping, but always giving the element (15) the possibility of rotating with the hinge component (14) and relatively to the cone-shaped body (19) and to the striker plate (16) which remain stationary seeing that they are constrained to the stationary component (13) of the hinge through the anchorage element (25).

Figs. 7 and 8 show the coupling of the various elements and how the device can block the rotation of the door because of the friction developed by the cone-shaped body (17) in the rotating element (15).

Claims

1) A door and window stop device for any partially or totally open position which is fitted to hinges each having a stationary component constrained to the case and a rotating component constrained to the door of the frame, the device having a rotating element (15) splined to the rotating component of the hinge, a striker plate (16) and an intermediate friction joint (17) for the coupling of said rotating element (15) and striker plate (16), characterized in that the striker plate (16) is fixed to the case of the frame and in that the intermediate friction joint (17) couples with said striker plate (16) without rotating but with the possibility of being positioned in an orthogonal direction to the surface of the case to which the fixed element is fitted in order to adjust the space between said case and the axis of the hinge.

2) A device in accordance with claim 1, characterized in that the striker plate (16) has a tab (16b) on its back with holes (16c) for screws (18) so as to be fixed to the case and has an open or closed slit (16a) which extends in an orthogonal direction to said tab.

3) A device in accordance with claims 1 and 2, characterized in that the rotating element (15) which is splined to the rotating component of the hinge has an axial cone-shaped slot (15b), in that the intermediate friction joint (17) has a cone-shaped body (19) which is inserted in said cone-shaped slot (15b), a splining ring (20) which rests on the rotating element (15) and couples without rotating with the cone-shaped body (19) and a screw (21) for the axial fitting of the cone-shaped body to said ring and for the adjustable friction blocking of said cone-shaped body in the cone-shaped slot of said rotating element (15), and in that said splining ring (20) has a shank (20b) which is inserted in the slot (16a) of the striker plate (16) constrained to the case.

4) A door or window stop device for any partially open or closed position fitted to hinges, each having

a stationary component (13) which is constrained to the case and a rotating component which is constrained to the door of the frame, the device having a rotating element (15) splined to the rotating component of the hinge, a striker plate (16) and a friction joint (17) placed between said rotating element (15) and striker plate (16), characterized in that an anchorage element (25) is splined to the stationary component (13) of the hinge on the axis and on one side of the rotating element (15), in that the striker plate (16) is placed on the axis and on the other side of the rotating element, said anchorage element (25) and said striker plate (16) being fixed to each other, and in that the friction joint (17) is placed between the rotating element (15) and said striker plate (16), said friction joint being made from a cone-shaped body (19) inserted in a cone-shaped slot (15b) formed in said rotating element (15) and is coupled to said striker plate (16) without rotating and from a screw (21) to axially fit the cone-shaped body (19) to said striker plate (16) and to block said cone-shaped body (19) in said cone-shaped slot (20) through adjustable friction.

5) A device in accordance with claim 4, characterized in that said anchorage element (25) and said striker plate (16) are axially placed on opposite sides of the rotating element (15) and tightly joined to each other through a blade (117) which parallelly extends on the outside of said rotating element.

6) A device in accordance with claim 5, characterized in that said blade (117) is inserted and blocked in openings (125a, 116a) formed on one part of the anchorage element (25) and the striker plate (16), said openings being formed in lateral protrudances of said elements.

7) A device in accordance with claim 5, characterized in that said blade (117) is integral with one of said anchorage elements (25) and striker plate (16) and is inserted and blocked in an opening formed in the other said element.

5

10

15

20

25

30

35

40

45

50

55

5

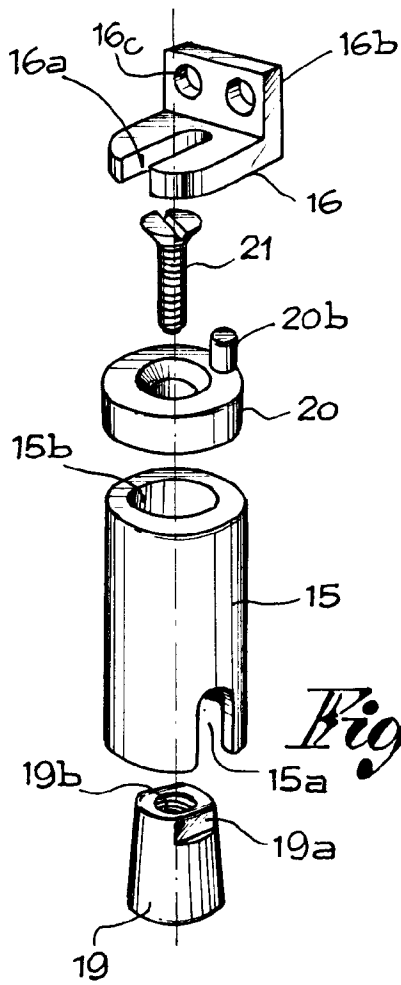

Fig. 2

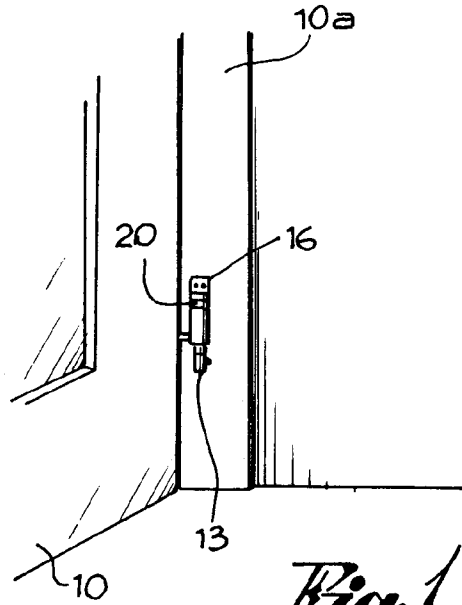

Fig. 1

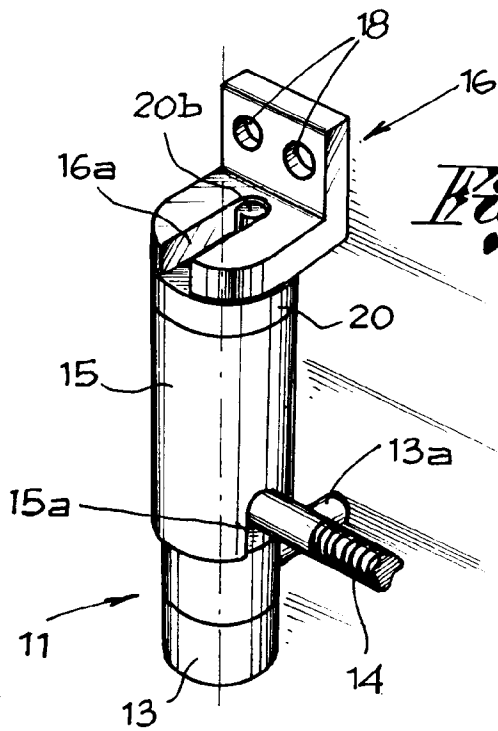

Fig. 3

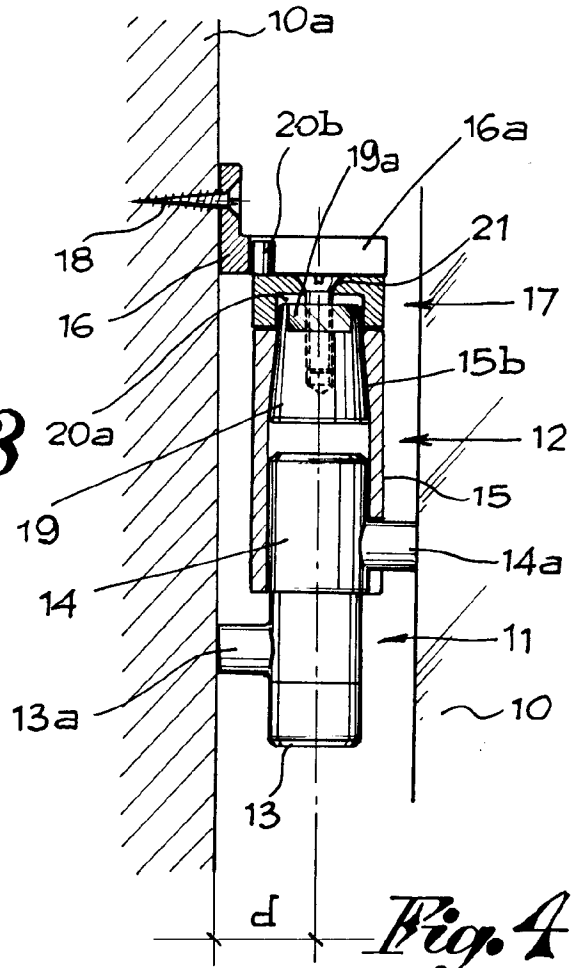

Fig. 4

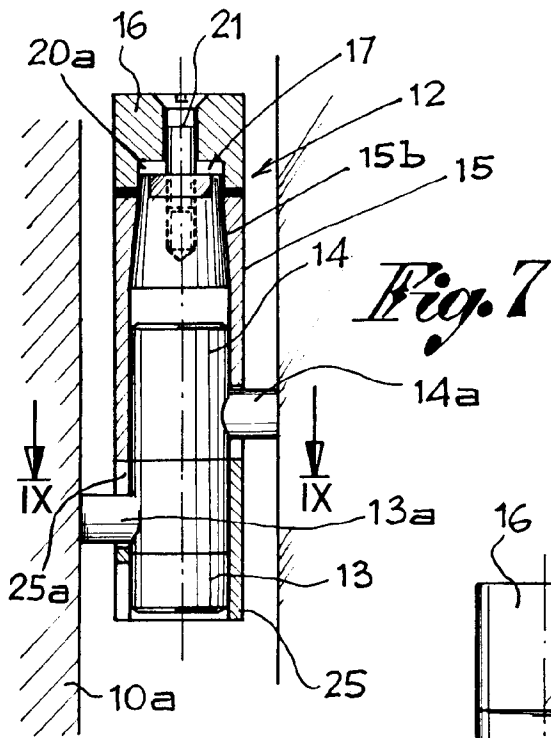

Fig. 7

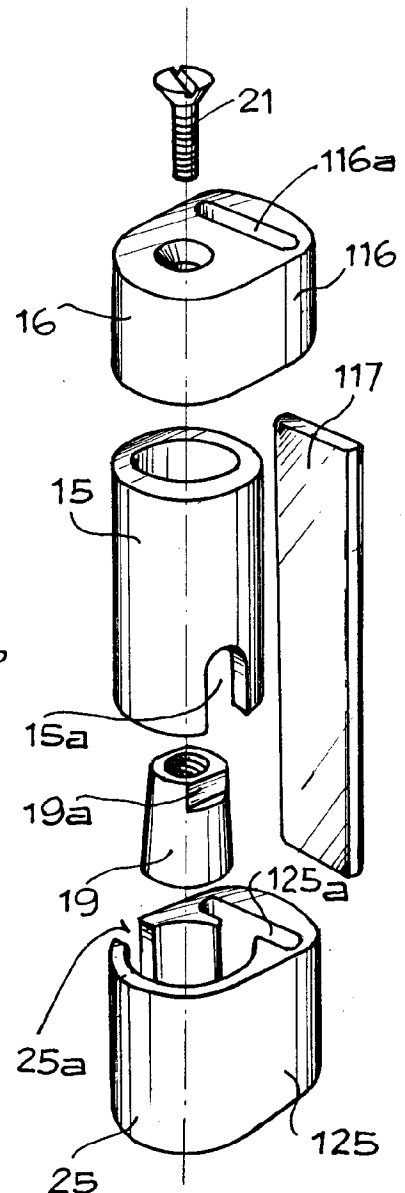

Fig. 6

Fig. 8

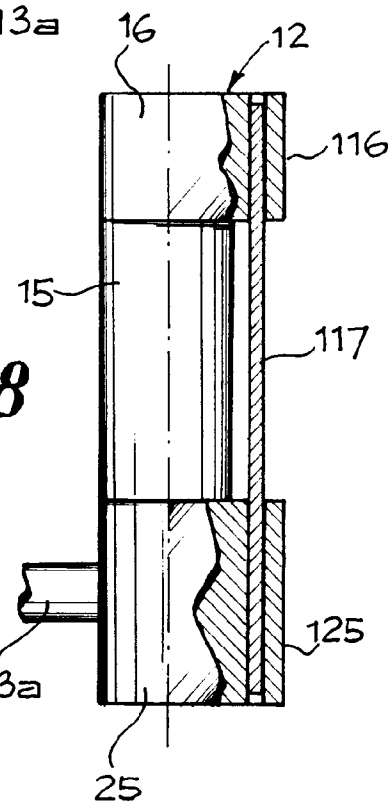

Fig. 5

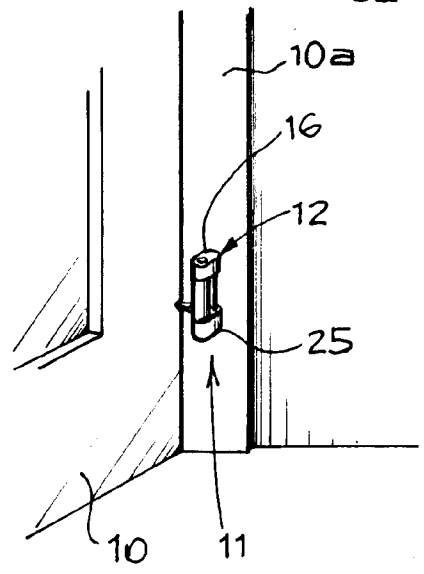
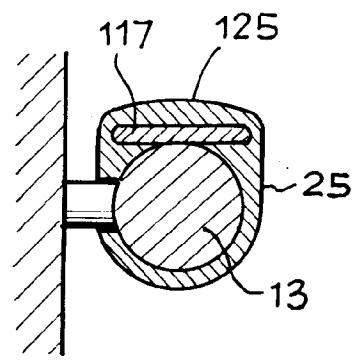

Fig. 9





European Patent
Office

EUROPEAN SEARCH REPORT

Application Number

EP 92 83 0188

DOCUMENTS CONSIDERED TO BE RELEVANT			
Category	Citation of document with indication, where appropriate, of relevant passages	Relevant to claim	CLASSIFICATION OF THE APPLICATION (Int. Cl.5)
A	US-A-1 610 404 (WINFREY) * page 2, line 91 - line 130; figures 6-9 * ---	1-4	E05D11/08
A	US-A-1 839 665 (FERRIS) * page 1, line 86 - line 98; figures 1,2 * ---	1	
A	FR-A-1 351 500 (GRENIER) * the whole document * -----	4	
			TECHNICAL FIELDS SEARCHED (Int. Cl.5)
			E05D
The present search report has been drawn up for all claims			
Place of search THE HAGUE		Date of completion of the search 29 JULY 1992	Examiner GUILLAUME G. E. P.
<p>CATEGORY OF CITED DOCUMENTS</p> <p>X : particularly relevant if taken alone Y : particularly relevant if combined with another document of the same category A : technological background O : non-written disclosure P : intermediate document</p> <p>T : theory or principle underlying the invention E : earlier patent document, but published on, or after the filing date D : document cited in the application L : document cited for other reasons & : member of the same patent family, corresponding document</p>			

EPO FORM 1503 00.82 (P0401)