



(12) **EUROPEAN PATENT APPLICATION**

(21) Application number : **92303128.0**

(51) Int. Cl.⁵ : **F42C 17/02, B25B 23/18**

(22) Date of filing : **08.04.92**

(30) Priority : **08.04.91 GB 9107375**

(72) Inventor : **Duckworth, Michael Joseph**
11, Gloucester Road
Grantham, Lincolnshire, NG 31 8RJ (UK)

(43) Date of publication of application :
04.11.92 Bulletin 92/45

(84) Designated Contracting States :
AT BE DE ES FR GB IT SE

(74) Representative : **Goodenough, Nigel et al**
A.A. Thornton & Co. Northumberland House
303-306 High Holborn
London WC1V 7LE (GB)

(71) Applicant : **ASTRA HOLDINGS PLC**
Springfield Road
Grantham, Lincolnshire NG31 7JB (GB)

(54) **Fuse setting tool.**

(57) A fuse setting tool comprises a manually grippable body (5, 6), and an aperture (7) in the body is adapted to cooperate around a rotatable portion of the fuse. Detent means (8) are provided within the aperture which cooperate drivingly with detent means (4) of the fuse. A light source means (9) is disposed on the body to illuminate at least a portion of the fuse, and means are provided to power the light source means.

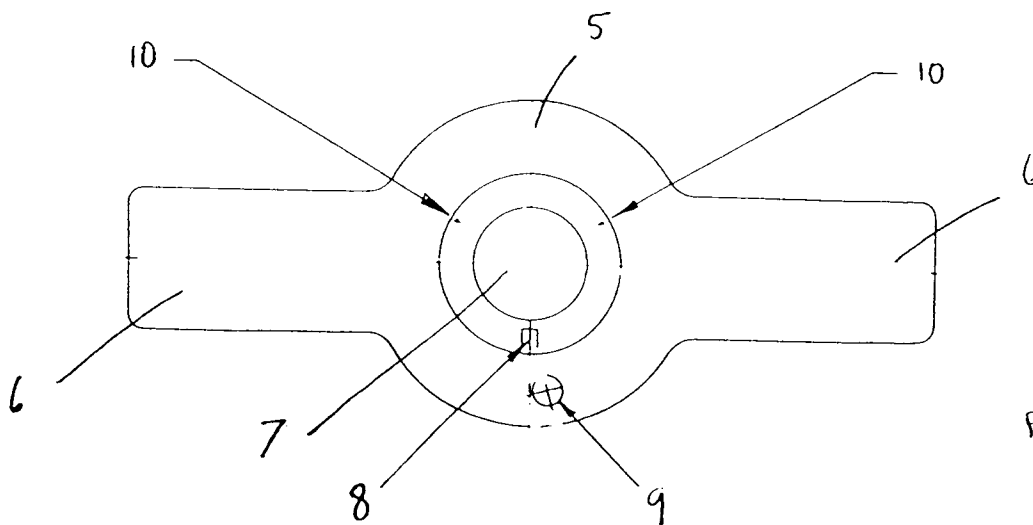

Fig 3

The present invention relates to fuse setting tools. More particularly, but not exclusively, it relates to a fuse setting tool of the type which is manually graspable and may engage with the fuse to rotate a portion thereof to set a time delay or the like.

Fuses may be attached to the front of shells or mortar bombs and may comprise a frustocone having one section which is rotatable with respect to an adjacent section about the axis of the cone. The fixed section may be marked with times in order to delay explosion of the shell or mortar bomb. These are generally arranged at angular intervals around the fixed portion. The rotatable section adjacent thereto includes a pointer and means to rotate the section. In order to set the time delay on a fuse, the rotatable portion is rotated until the pointer is aligned with the desired time delay indication.

Fuses of the type described may suffer from the disadvantage that rotation of the rotatable section is not always easy. For example, where the shell or mortar bomb is to be used in arctic or cold conditions, the user may be wearing gloves and find it difficult to manipulate the rotatable portion with the degree of accuracy required. In hot conditions, the fingers of the user may be slippery due to perspiration and this may render accurate setting difficult, especially when one considers that these fuses must be set quickly and in trying conditions.

Furthermore, shells and mortar bombs are often used at night or in conditions of low illumination and it is not always easy for the user to see the time delay indication which is desired. Often, a second person has to stand nearby with a torch to allow accurate setting to be made.

It is an object of the present invention to provide a fuse setting tool which overcomes the above disadvantages.

According to the present invention there is provided a fuse setting tool comprising a manually grippable body, an aperture in said body adapted to cooperate around a rotatable portion of the fuse, detent means within said aperture to cooperate drivingly with detent means of the fuse, light source means disposed on said body to illuminate at least a portion of said fuse, and means to power said light source means.

Preferably said light source means is so located as to illuminate a zone of the fuse in which a time pointer indicator is located, and a portion of a time scale to which said indicator is pointed.

Said body may include two contact means adapted to contact electrically the fuse or munition containing it, when the tool is in an operable position, one of said contacts being connected to the power source and one to said light source. Correct positioning of the tool thus acts as a switch to cause illumination of the light source.

The body is preferably an integral moulding of plastics material, which may optionally be nylon.

The detent means may comprise a pin projecting within the aperture of the body to cooperate with a scallop of the fuse.

The aperture may be frustoconical of a cone angle to cooperate with the fuse.

The light source is preferably a LED (light emitting diode), optionally coloured, e.g. red. It may be powered by a lithium/manganese dioxide battery encapsulated within the body and may pass a current of 20 mA through the fuse.

An embodiment of the present invention will now be more particularly described by way of example and with reference to the accompanying drawings, in which:

FIGURE 1 is a side elevation of a typical fuse for use with the present invention;
FIGURE 2 is a cross-sectional view of a fuse setting tool embodying the present invention; and
FIGURE 3 is a plan view from below of the fuse setting tool of Figure 2.

Referring now to Figure 1 of the drawings, there is shown a fuse for attachment to a shell or mortar bomb and which comprises a fixed ring 1 having spaced around its periphery indications of time delay settable by the fuse. Adjacent thereto is a rotatable ring 2 having a time pointer 3 marked thereon for cooperating with the indications on the fixed ring 1 to set the time delay. The rotatable ring 2 is driven by means of a drive scallop 4.

Referring now to Figures 2 and 3, there is shown a tool which comprises a moulding of nylon or similar plastics material having a central portion 5 and a pair of oppositely directed radially extending arms 6. The central portion 5 has a central aperture 7 which is dimensioned to fit around the rotatable portion 2 of the fuse. The aperture 7 is correspondingly tapered.

Within the aperture is a drive key 8 adapted to cooperate with the drive scallop 4 of the fuse. Also in the central portion of the tool body 5 is an LED 9 adapted to give a low but useable level of illumination in the region of the time pointer 3 and the portion of the scale to which it is pointing. The LED may be red to prevent deterioration of night vision. The LED 9 or other solid state light source is powered by means of a battery, such as a lithium/manganese dioxide safety cell. The circuit includes a resistor and a pair of contacts 10 within the aperture 7. The LED is only illuminated when electrical connection is made between these contacts 10, and this may be achieved by correctly positioning the tool on the fuse, the fuse itself acting as a conductor. Thus, the light is only illuminated when the holder is in position, and the user may determine when the holder is in position by noting when the LED is lit. The current passed through the fuse between battery and LED is of the order of 20 mA and thus quite safe. Indeed, it could be as high as 2A without danger to safety.

The electrical components may be moulded in

position within the tool body and are sufficiently cheap to allow the tool to be discardable after a number of uses.

Use of the tool enables single handed setting of fuses, even in arctic or other adverse conditions and at night. 5

the light source is powered by a lithium/manganese dioxide battery encapsulated within the body.

Claims

- 10
1. A fuse setting tool comprising a manually grippable body (5), an aperture (7) in said body adapted to cooperate around a rotatable portion of the fuse, detent means (8) within said aperture to cooperate drivingly with detent means of the fuse, light source means (9) disposed on said body to illuminate at least a portion of said fuse, and means to power said light source means. 15
 2. A tool according to Claim 1, characterised in that said light source means is so located as to illuminate a zone of the fuse in which a time pointer indicator (3) is located, and to illuminate a portion of a time scale (1) to which said indicator is pointed. 20 25
 3. A tool according to Claim 1 or Claim 2, characterised in that said body may include two contact means adapted to contact electrically the fuse or munition containing it, when the tool is in an operatable position, one of said contacts being connected to the power source and one to said light source, such that correct positioning of the tool acts as a switch to cause illumination of the light source. 30 35
 4. A tool according to any preceding claim, characterised in that the body is formed from an integral moulding of plastics material. 40
 5. A tool according to any Claim 4, characterised in that said plastics material is nylon.
 6. A tool according to any preceding claim, characterised in that the detent means comprise a pin projecting within the aperture of the body to cooperate with a scallop of the fuse. 45
 7. A tool according to any preceding claim, characterised in that the aperture is frustoconical, with a cone angle adapted to cooperate with the fuse. 50
 8. A tool according to any preceding claim, characterised in that the light source is a light emitting diode which may be red. 55
 9. A tool according to Claim 8, characterised in that

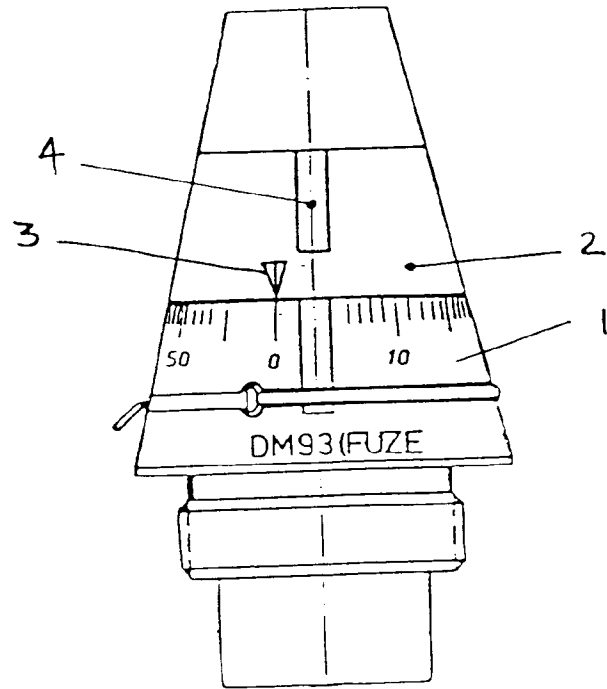

FIG 1

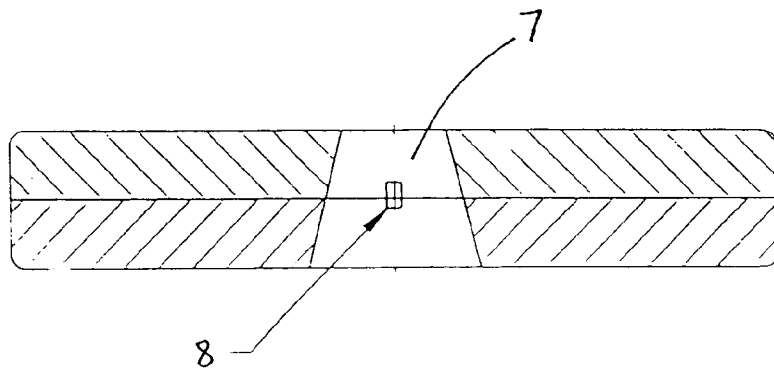

FIG 2

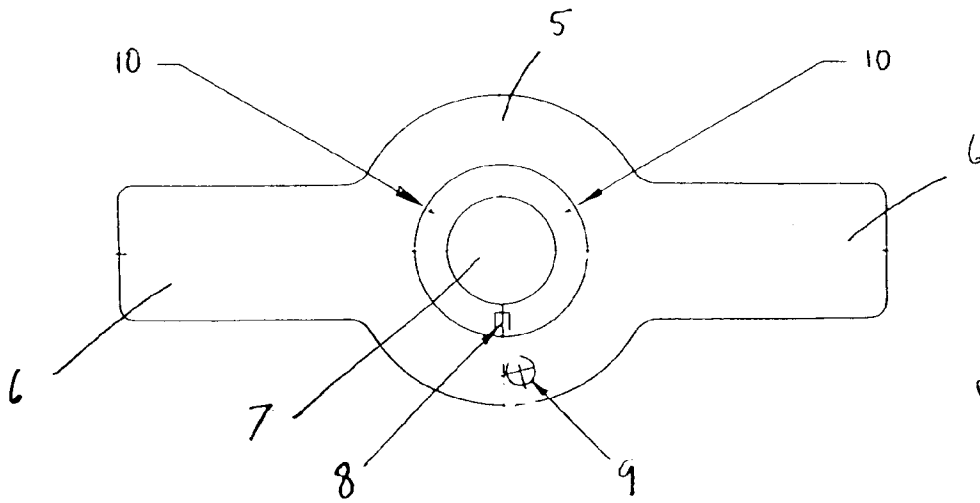

FIG 3



European Patent Office

EUROPEAN SEARCH REPORT

Application Number

EP 92 30 3128

DOCUMENTS CONSIDERED TO BE RELEVANT			
Category	Citation of document with indication, where appropriate, of relevant passages	Relevant to claim	CLASSIFICATION OF THE APPLICATION (Int. Cl.5)
X	CH-A-80 982 (A. ROBERT) * page 1, left column, line 1 - right column, paragraph 1; figures 1-6 * * page 5, left column, paragraph 5 *	1, 2, 6, 7	F42C17/02 B25B23/18
Y	---	3, 4, 5, 8, 9	
Y	US-A-4 253 134 (H. BARNABY) * column 1, line 36 - line 41; figures 1-10 * * column 2, line 18 - line 44 * * column 3, line 3-6 *	3	
Y	FR-A-1 368 851 (J. VERNA) * the whole document *	4, 5, 8, 9	
Y	FR-A-1 267 576 (G. BLUM) * page 2, right column, paragraph 4-6; figure 1 *	8	
Y	GB-A-555 249 (PHELAN) * page 1, line 93 - page 2, line 14; figure 1 *	1, 2, 6, 7	TECHNICAL FIELDS SEARCHED (Int. Cl.5)
Y	US-A-2 304 790 (G. BEATTY) * page 1, left column, line 46 - line 54; figures 1, 2 * * page 1, right column, line 18 - line 44 *	1, 2, 6, 7	F42C B25B
A	CH-A-518 159 (SCHLEH) * the whole document *	1, 2, 6	
A	US-A-4 324 158 (LE ROY)		
A	US-A-2 466 342 (WATTS)		
The present search report has been drawn up for all claims			
Place of search THE HAGUE		Date of completion of the search 26 AUGUST 1992	Examiner VAN DER PLAS J.
CATEGORY OF CITED DOCUMENTS X : particularly relevant if taken alone Y : particularly relevant if combined with another document of the same category A : technological background O : non-written disclosure P : intermediate document		I : theory or principle underlying the invention E : earlier patent document, but published on, or after the filing date D : document cited in the application L : document cited for other reasons & : member of the same patent family, corresponding document	

EPO FORM 1503 03.92 (P0401)