



Europäisches Patentamt
European Patent Office
Office européen des brevets



(11) **EP 0 512 549 B2**

(12) **NEW EUROPEAN PATENT SPECIFICATION**

(45) Date of publication and mention
of the opposition decision:
25.09.2002 Bulletin 2002/39

(51) Int Cl.7: **B41C 1/10**, B41C 1/12

(45) Mention of the grant of the patent:
28.06.1995 Bulletin 1995/26

(21) Application number: **92107737.6**

(22) Date of filing: **07.05.1992**

(54) **Printing press**

Druckmaschine
Presse à imprimer

(84) Designated Contracting States:
DE FR GB

(30) Priority: **10.05.1991 JP 10589891**
10.07.1991 JP 16956191

(43) Date of publication of application:
11.11.1992 Bulletin 1992/46

(73) Proprietor: **FUJI PHOTO FILM CO., LTD.**
Kanagawa-ken (JP)

(72) Inventor: **Naniwa, Mutsumi,**
c/o Fuji Photo Film Co., Ltd.
Haibara-gun, Shizuoka (JP)

(74) Representative: **Grünecker, Kinkeldey,**
Stockmair & Schwanhäusser Anwaltssozietät
Maximilianstrasse 58
80538 München (DE)

(56) References cited:

EP-A- 0 406 157	WO-A-92/-07716
DE-A- 1 961 687	DE-A- 3 911 932
US-A- 3 347 160	US-A- 3 347 160
US-A- 3 475 760	US-A- 3 741 118
US-A- 3 745 235	US-A- 4 395 946
US-A- 4 395 946	US-A- 4 936 211
US-A- 4 936 211	US-A- 4 990 969

- **PATENT ABSTRACTS OF JAPAN** vol. 007, no. 216 (P-255) 24 September 1983; JP-A-58 111 053 (OLYMPUS KOGAKU KOGYO KK) 1 July 1983
- **PATENT ABSTRACTS OF JAPAN** vol. 013, no. 028 (M-788) 23 January 1989; JP-A-63 239 056 (DAINIPPON SCREEN MFG CO. LTD) 5 October 1988
- **XEROX Disclosure Journal, Volume 1, No.4,** April 1976, p.19

EP 0 512 549 B2

Description

[0001] This invention relates to a printing press according to the precharacterizing portion of claim 1 as it is known from US PS 4 395 946.

[0002] There have conventionally been used many models of rotary press in which a printing pressure is applied between the cylindrical press plate attached to a plate cylinder and the surface of an impression cylinder, so that the ink on the plate is transferred onto the printing paper on the surface of the impression cylinder. Rotary presses have two advantages over platen presses: first, the plane of contact between the press plate and the surface of the impression cylinder is substantially linear, making it possible to reduce the pressure loading; second, in the absence of reciprocating motions, the drive mechanism is simple enough to permit high-speed printing. Because of these advantages, rotary presses are extensively used in various printing processes including letterpress, intaglio and lithography.

[0003] Rotary presses can be operated either by direct printing in which the impression cylinder is used as a means of pressing the printing paper directly onto the plate cylinder fitted with the press plate, or by offset printing in which the ink on the press plate is transferred from the plate cylinder to an intermediate rubber-covered blanket cylinder, from which its image is transferred to the paper on the impression cylinder. Most letterpress and intaglio is done by the direct printing method since the press plate has comparatively high strength, whereas most lithography is done by the offset printing method since the strength of the press plate is comparatively weak.

[0004] The rotary press as described above comprises a feeder, an ink supplier, a pressure applicator and a delivery and, in case of a lithographic press, a dampening water supplier is also provided. While many cylinders and rolls are needed, a sheet feeding type multicolor printing press in which inks of more than one color are printed in superposition on a single sheet is worth particular mention since even the pressure applicator taken alone needs many cylinders. For example, in case of direct printing in four colors, four plate cylinders, four impression cylinders and at least three transfer cylinders are necessary, which means a total of eleven cylinders are needed at minimum. In case of an offset press, four rubber-covered blanket cylinders are additionally required.

[0005] A prior art rotary four-color sheet feeding lithographic offset press in common use is illustrated in Fig. 13. The press generally indicated by 100 comprises four sets of plate cylinders 102, blanket cylinders 104, impression cylinders 106 and transfer cylinders 108, each set being assigned to either one of four colors, yellow (Y), magenta (M), cyan (C) and black (B). Thus, a total of 16 cylinders are used in the press. Shown by 110 is a dampening water supplier, 112 is an ink supplier, 114

is a feeder and 116 is a delivery.

[0006] In prior art models of rotary multicolor press, a set of plate cylinder, impression cylinder, transfer cylinder and, in the case of the offset press shown in Fig. 13, a blanket cylinder, too, is necessary for each color and the number of cylinders that must be used increases unavoidably (as many as 16 cylinders are needed in the press shown in Fig. 13), increasing the structural complexity of the press. As a result, the number of machine parts increases, not only making the assembly and maintenance operations cumbersome but also increasing the noise that develops during the driving of the press. In addition, the press becomes bulky to increase its production cost.

[0007] For n -color printing, n press plates for n colors are mounted on individual plate cylinders and printing is done with registration achieved between colors. In printing, even in black-and white printing, registration need only to be accomplished by properly positioning the printing paper with respect to the press plate; however, in multicolor printing, registration must be achieved between press plates of different colors. Since this requires a particularly high precision as exemplified by a permissible error of ca. 0.03 mm, various complex mechanisms are provided in plate cylinders and other components. For example, plate cylinders are equipped with both a running register for achieving registration in the longitudinal direction and a side register for achieving registration in the transverse direction and, in certain types of presses, registers are also provided for adjusting torsions as in cocking. This has added to the complexity of the mechanism of plate cylinders, leading to the increase in the production cost of printing presses.

[0008] To achieve registration, the operator does actual printing with the press plates installed on the plate cylinders; then checks the amount of offset from registration either by looking at the print (proof) or by measurement with a suitable instrument, and achieves complicated adjustments of the plate cylinders by means of the above-described registers of complicated mechanisms. Hence, the operator who does registration is required to have high skill. An automatic control mechanism of a feedback system could be adopted to automate not only the measurement of the amount of offset from registration by proofing but also the registration work on the basis of the measured values; however, the automatic control system has had the problems of complexity and high cost. Further both the registration with skilled operators and the automatic registration mechanism have suffered from the problem that the occurrence of spoilage is unavoidable since proofing is effected in either case.

[0009] From DE-A-1 961 687 a method and an apparatus is disclosed wherein a single plate cylinder allows press plates for several colours and wherein each colour image is transferred while being kept in register to a single blanket cylinder before the combined colour images are transferred to a sheet or web.

[0010] Direct platemaking is also implemented today, in which process the image data read from an original document or a block copy or the image data composed with a computer or an image processor is processed and the images of respective colors are digitally exposed on the original plate under laser light or the like, followed by development and any other subsequent treatments to make a press plate. However, in the prior art, the making of press plates has been effected for each of the colors to be printed by a separate platemaking process; namely, the platemaking process has been entirely independent of the printing process. Hence, even in the case of direct platemaking, the platemaking equipment is entirely dependent of the printing press and the overall process which starts with the platemaking and involves printing to yield printed matter cannot be simplified. Another problem with the prior art has been that the platemaking process is in itself time-consuming since it has to be performed for each of the colors to be reproduced.

BRIEF SUMMARY OF THE INVENTION

[0011] The present invention has been accomplished under these circumstances and its object is to provide a multicolor printing press that is easy to operate in that it enables a plurality of press plates to be prepared simultaneously even in the case of multicolor printing, thereby shortening the process time including platemaking and printing operations, that is simple enough in construction to realize a compact and small-sized system, and that permits printing to be done at comparatively high speed.

[0012] To achieve the above-described object, there is provided a multicolor printing press that comprises a single plate cylinder that allows press plates for n colors to be disposed cylindrically at predetermined intervals, n platemaking units that are disposed on the circumference of said plate cylinder for individually preparing press plates for single colors, an ink supply assembly for the n colors, and an impression cylinder whose diameter is one- n th of that of said plate cylinder, said impression cylinder having a single sheet of printing paper wrapped around it and delivering said printing paper after it has made n consecutive revolutions.

[0013] Preferably, said platemaking units and said ink supply assembly are both movable in a direction parallel to the central axis of said plate cylinder so that they are alternately located in the same position over said plate cylinder.

[0014] Preferably, said platemaking units comprise a drawing section that writes (records) an image on an unexposed original plate wound onto said plate cylinder and a plate processing section that processes said original plate to prepare a press plate.

[0015] Preferably, said original plate is a light-sensitive material.

[0016] Preferably, said original plate is an electrophotographic photoreceptor.

[0017] Preferably, said drawing section is composed of a laser exposing unit.

[0018] Preferably, said plate processing section is composed of a wet developing unit.

5 **[0019]** Preferably, said printing press further includes an original plate supply mechanism within said plate cylinder, said mechanism winding up the plate with which a printing process has been completed and unwinding an unexposed original plate.

10 **[0020]** Preferably, said printing press further includes an ink transfer blanket cylinder between said plate cylinder and said impression cylinder.

15 **[0021]** Preferably, said blanket cylinder has the same diameter as said plate cylinder or said impression cylinder.

[0022] Preferably, said press plate is for letterpress, intaglio or lithography.

20 **[0023]** Preferably, said printing press uses a lithographic plate as said press plate, and further includes a dampening water supply assembly for supplying dampening water to said press plate.

BRIEF DESCRIPTION OF THE DRAWINGS

25 **[0024]**

Fig. 1 is a cross-sectional view showing schematically an embodiment of the printing press according to the present invention;

30 Fig. 2 is a cross-sectional view showing schematically an embodiment of a printing press which comprises a single plate cylinder and a single plate making unit;

35 Fig. 3 is a cross-sectional view showing schematically an embodiment of the platemaking unit employed within a printing press according to the present invention;

40 Fig. 4 is a cross-sectional view showing schematically an embodiment of the ink supplier of the printing press employed in the present invention;

Fig. 5 is a cross-sectional view showing schematically an embodiment of the dampening water supplier of the printing press employed in the present invention;

45 Fig. 6 is a cross-sectional view showing schematically another, embodiment of a printing press having a single plate cylinder and a single plate making unit;

50 Fig. 7 is a cross-sectional view showing schematically yet another embodiment of a printing press having a single plate cylinder and a single plate making unit;

55 Fig. 8 is a cross-sectional view showing schematically a further embodiment of a printing press having a single plate cylinder and a single plate making unit;

Fig. 9 is a cross-sectional view showing schematically another embodiment of the printing press ac-

ording to the present invention;

Fig. 10 is a cross-sectional view showing schematically yet another embodiment of the printing press according to the present invention;

Fig. 11 is a cross-sectional view showing schematically a further embodiment of the printing press according to the present invention;

Fig. 12 is a partial perspective view showing still another embodiment of the printing press according to the invention; and

Fig. 13 is a cross-sectional view showing schematically a prior art printing press.

DETAILED DESCRIPTION OF THE INVENTION

[0025] The printing press of the present invention is described hereinafter in greater detail. To begin with, we describe a printing press having a single plate cylinder and a single plate making unit which is not part of the invention.

[0026] In this printing press, an unexposed or a fresh original plate (yet to be processed press plates) is wrapped around a single plate cylinder. In the platemaking unit of the press, the images of n colors which have typically been subjected to digital processing in the drawing section are successively written as either latent or visible images in separate colors on the original plate with laser light or the like as it is wrapped around the plate cylinder; then, the images are processed in the plate processing section to form press plates on the plate cylinder; these steps are repeated the necessary times to prepare press plates on the surface of which the images of n colors have been correctly written at equal distances, each being one-nth of the circumference of the plate cylinder. As the plate cylinder carrying the press plates for n colors rotates, a plurality of ink supply units for the respective colors that are provided around the plate cylinder will successively supply inks of those colors, with each ink being deposited only at the time when the image of the corresponding color (or the press plate carrying that image) on the plate cylinder has come to the right position. If the press plates are for lithography, dampening water may be supplied to the plates, as required, by means of dampening water supply units before the inks are supplied. As the plate cylinder rotates, the impression cylinder that contacts the plate cylinder either directly or via a rubber-covered blanket cylinder, that has a diameter one-nth of that of the plate cylinder and that holds a single sheet of printing paper wrapped around it rotates in forward direction at the same peripheral speed as the surface of the press plate on the plate cylinder; when the impression cylinder rotates fully once, the ink image of one color on a press plate on the plate cylinder is transferred onto the printing paper either directly or after it is transferred to the intermediate blanket cylinder. When the impression cylinder has made n revolutions as it holds the printing paper, the plate cylinder rotates fully once and by repeating the

transfer step n times, n colors are printed on the paper. When the printing of n colors has been effected in this manner, the impression cylinder releases the paper on which n colors have been printed and holds a freshly supplied sheet of printing paper so that it is subjected to another printing cycle.

[0027] Such a printing press is simple in construction and compact enough to realize a small-sized system; further, it does not require registration even in multicolor printing, can be easily operated even by unskilled operators and enables printing to be done at comparatively high speed. The printing press is applicable to various types of press plates whether they are for letterpress, intaglio or lithography (either in the presence or absence of dampening water); at the same time, it is applicable to both direct printing and offset printing.

[0028] A printing press which comprises a single plate cylinder and a single plate making unit is described below with reference to embodiments shown in Fig. 2-8. These embodiments disclose background art which is useful for understanding the invention.

[0029] Fig. 2 is a cross-sectional view showing schematically an embodiment of a printing press. As shown, the printing press generally indicated by 10 is a direct-process rotary sheet feeding four-color lithographic offset press that uses dampening water and which comprises the following components: a single plate cylinder 12 around which press plates 28 (exposed) for four colors can be formed at given intervals; a platemaking unit 14 positioned around and near the plate cylinder 12; an ink supply assembly 16 for four colors B, C, M and Y; a rubber-covered blanket cylinder 18 onto which ink images are to be transferred from the press plates 28; a dampening water supply assembly 20 for four colors; an impression cylinder 22 whose diameter is one-fourth the diameter of the plate cylinder 12; a feeder unit 24 for supplying the printing paper onto the impression cylinder 22; a delivery unit 25 to be loaded with printed paper; and an original plate supply unit 26 within the plate cylinder 12 by which the spent press plates 28 are wound up whereas an unexposed original plate 29 is unwound.

[0030] The plate cylinder 12 is used to position the exposed press plates 28 for the four colors B (black), C (cyan), M (magenta) and Y (yellow) on its circumference at given intervals, say, at equal distances. The unexposed original plate 29 can be installed on the entire circumference of the plate cylinder 12. Images of the four colors B, C, M and Y are written on the original plate 29 at equal distances, namely, at 90° out of phase so as to prepare the four-color press plates 28. The plate cylinder 12 has its diameter adjusted to be smaller by the thickness of the original plate 29 (press plates 28) to be wound. The original plate 29 is tightly wrapped around the plate cylinder 12 as it is held taut and thereafter fixed in position. In the case shown in Fig. 2, the original plate 29 is fixed on the circumference of the plate cylinder 12 as it is stretched by means of the original plate supply unit 26. However, a plate clamp (not

shown) may be employed that wraps a single original plate 29 (press plates 28) around the entire circumference of the plate cylinder 12 and which stretches it for fixation, as shown in Fig. 6. The method of fixing the original plate 29 on the plate cylinder 12 is in no way limited and any other methods that are known in the art may be applicable.

[0031] In the embodiment shown in Fig. 2, the exposed press plates 28 for the four colors B, C, M and Y are formed around the single plate cylinder 12 so that the latter is a quadruple (4-fold) cylinder of the impression cylinder 22. However, exposed press plates for \underline{n} colors may be formed at given intervals around the single plate cylinder 12 so that it is used as an \underline{n} -fold cylinder of the impression cylinder 22, where \underline{n} may be any natural number but is preferably 2 or more. The distance between adjacent exposed press plates 28 which are \underline{n} in number is in no way limited as long as it is of a predetermined value. Preferably, the press plates 28 are disposed at equal distances that correspond to one- \underline{n} th of the total circumference of the plate cylinder 12.

[0032] The platemaking unit 14 comprises the drawing section 30, the plate processing section 32 and the platemaking unit loading/unloading device (not shown). In the embodiment shown in Fig. 3, an electrophotographic photoreceptor is used as the original plate 29, so the drawing section 30 comprises a corona charging device 34 that provides a charging zone for creating a uniform charge layer on the photoreceptor 29 and an exposure unit 36 that illuminates the charged photoreceptor 29 with laser light to form an electrostatic latent image on it. The plate processing section 32 comprises a developing unit 38 that develops with a wet toner the electrostatic latent image formed on the exposed photoreceptor, a fixing unit 40 for fixing the developed toner image on the photoreceptor 29, and a treating unit 42 for rendering the fixed image carrying photoreceptor 29 (press plates 28) hydrophilic.

[0033] The corona charging device 34 is provided in the charging zone and it may be of any type that is capable of forming a uniform charge layer on the photoreceptor 29. The exposing unit 36 is such that the photoreceptor (original plate) 29 moving at a predetermined slow scan (subscanning) speed on the plate cylinder 12 rotating at a predetermined speed is exposed to laser light, whereby a digital halftone image of a certain monochromatic color is written as a latent image on that photoreceptor 29. The exposing unit 36 comprises the following components: a laser light source 44 for emitting a laser beam L; an optical modulator 45 such as an AOM (acoustooptical modulator) that modulates the intensity of laser beam L in accordance with the image of the block copy; a light deflector 46 such as a rotating polygonal mirror that reflects and deflects the intensity-modulated laser beam L so that it is scanned at the exposing position 36a in a fast scan (main scanning) direction that is generally perpendicular to the direction in which the plate cylinder 12 rotates (i.e., the direction in which the

photoreceptor is fed); a scanning lens 47 such as an $f\theta$ lens that focuses the laser beam L in such a way that it will have a uniform spot diameter at any fast scan (main scanning) position on the original plate 29 on the plate cylinder 12; a modulator circuit 48 for driving the optical modulator 45; and an image processor 49 which first produces a digital halftone image signal by performing digital processing on the image of the block copy and which then supplies it as an analog image signal after D/A conversion.

[0034] The laser light source 44 may be of any type such as a semiconductor laser (a laser diode: LD) or a gas laser (e.g. a He-Ne laser or an Ar laser) that emit at such wavelengths that the photoreceptor will have a spectral sensitivity higher than a predetermined value. A light-emitting diode (LED) can also be used if it has a satisfactory light intensity. If LD or LED is to be used, they may be directly modified without using the optical modulator 45. Besides the laser light source 44, conventional light sources such as a sodium lamp, a xenon lamp and a mercury lamp may also be used. The optical modulator 45 may be replaced by known optical shutters that use various linear or nonlinear electrooptical materials, as exemplified by liquid-crystal shutters and electrooptical effect shutters using PLZT. If the light deflector 46 is not used, an array of known optical shutters may be provided on the fast scanning (main scanning) line defined at the exposing position 36a, with those optical shutters being turned on or off (opened or closed) imagewise. If desired, the array of optical shutters may be replaced by an array of LDs or LEDs, with those LDs or LEDs being turned on or off imagewise.

[0035] The light deflector 46 is in no way limited to the rotating polygonal mirror and it may be selected from among any types that are capable of deflecting laser beam L through a predetermined angle in one-dimensional direction. For example, even a galvanometer mirror and resonant scanner can be used.

[0036] The image information single to be subjected to image processing by the image processor 49 may be an image signal as read from the block copy or alternatively it may be a digitized image signal as composed or prepared by electronic publishing or desktop publishing (DTP) by means of a microprocessor or a computer.

[0037] The developing unit 38 comprises the following components: a tank 50 containing a liquid toner developer F; a nozzle 51 for ejecting the liquid toner developer F; two developing electrodes 52 that define the nozzle 51; an ejection means 53 by which the liquid toner developer F is ejected through the nozzle 51; and a squeeze roller 54. In the developing unit 38, the toner particles in the liquid toner developer F being ejected through the nozzle 51 by the ejection means 53 are deposited in a given amount on the image area (where the electrostatic latent image is formed) in accordance with the strength of electric field between each developing electrode 52 and the photoreceptor, whereby toner development of the latent image is effected.

[0038] The fixing unit 40 is for fixing the toner image on the plate 29 that has been subjected to toner development in the developing unit 38 and which has been freed of excess liquid toner developer by means of a squeeze roller 54. Having this capability, the fixing unit 40 is composed of a lamp heater, a panel heater or any other heater that dries the plate 29 and which thermally fixes the toner image on it.

[0039] The treating unit 42 comprises the following components: a tank 55 containing a solution that renders the light-sensitive material 29 hydrophilic, such as an aqueous solution containing a ferrocyanide compound; a roller 56 for pumping the treating solution in the tank 55; and a roller 57 that deposits the pumped treating solution on the surface of the plate 29. In this treating unit 42, the non-image area of the light-sensitive layer of the plate 29 that has passed through the stages of toner development and toner image fixation is rendered hydrophilic with the deposited treating solution.

[0040] The platemaking unit loading/unloading device (not shown) allows the platemaking unit 14 to be contacted to the original plate 29 only in the platemaking process. The operation of the device is in no way limited and any other methods that are known in the art may be applicable.

[0041] Thus, the original plate 29 made of an electrophotographic photoreceptor passes through the steps of exposure, development, fixing and hydrophilic treatment in the platemaking unit 14, whereby a press plate 28 for one color is prepared. By repeating this procedure of plate preparation in the platemaking unit 14, press plates 28 are produced in which images for the four colors B, C, M and Y have been written at equal distances on the circumference of the single plate cylinder 12. In case of printing n colors, an n -fold plate cylinder may be employed to carry press plates 28 in which images for the n colors have been similarly written at equal distances on the circumference.

[0042] The electrophotographic photoreceptor used as the original plate 29 may be selected from among all examples of "resin dispersed" electrophotographic photoreceptors which comprise a flexible electroconductive base such as aluminum or plastics or paper that have been rendered conductive and an overlying light-sensitive layer that has a photoconductive material such as zinc oxide (ZnO) or cadmium sulfide (CdS) dispersed in a binder such as a resin. Aside from zinc oxide and cadmium sulfide, other photoconductive materials may be used and they include inorganic species such as titanium oxide and amorphous silicon and organic species such as phthalocyanine compounds. Typical examples of electrophotographic photoreceptors that use light-sensitive layers containing those photoconductive materials include Electrophotographic Master ELP Mark I and Mark II of a ZnS-dispersed-in-resin type which are both produced by Fuji Photo Film Co., Ltd.

[0043] In the embodiment shown in Fig. 3, the developing unit 38 performs wet toner development, but if the

electrophotographic photoreceptor used as the original plate 29 is of a certain selected type, the developing unit 38 may be adapted to perform dry toner development.

[0044] The original plate 29 to be used in the present invention also is not limited to electrophotographic photoreceptors, nor is the platemaking unit 14 limited to the case shown in Fig. 3. The platemaking unit 14 need not have both the drawing section 30 and the plate processing section 32 as shown in Fig. 2 and, instead, it may solely be composed of the drawing section 30. Thus, one may properly select the drawing section 30, as well as the plate processing section 32 in accordance with the specific type of original plate used.

[0045] For instance, a plate for direct digital printing press (DDPP) such as a photosensitive resin material (photopolymer) may be used as the original plate 29 in such a way that exposure is followed by "strip development", in which the exposed or unexposed areas are stripped to leave the image or non-image areas behind, which is then finished to prepare a plate for letterpress (as made of a resin) or intaglio. Alternatively, a photosensitive resin material, a light- and pressure-sensitive resin material, a light- and heat-sensitive resin material may be used as the original plate 29 in such a way that the image or non-image areas are exposed to harden to a lithographic, intaglio or relief plate. If desired, a presensitized (PS) plate may be used in such a way that after imagewise exposure, it is subjected to PS development to prepare a press plate. As another method, a silver halide photographic material may be used either independently or in addition to other light-sensitive materials. Alternatively, a heat-sensitive material such as a heat-sensitive resin material may be used in such a way that it is illuminated with heat rays such as laser light until the image or non-image areas harden thermally to prepare a press plate.

[0046] Aside from the use of a light source such as laser light for performing light or thermal exposure, the drawing section 30 of the platemaking unit 14 to be used in the printing press 10 may be operated by various other methods known in the art and they include: i) an impact process in which holes are made in the image or non-image areas on the surface of the original plate 29 by a physical means such as a needle so as to prepare a press plate for either intaglio or letterpress; ii) an ink-jet process in which minute drops of a liquid material are squirted from a special nozzle and steered in flight so that they are deposited on the image or non-image areas of the original plate 29, whereby oleophilic or hydrophilic areas are formed on its surface to prepare a lithographic plate; iii) an electroconductive base such as an aluminum base that has a silicon (Si) layer formed is used as the original plate 29 and the silicon layer is evaporated imagewise by means of an electric spark to prepare a press plate; and iv) a press plate is prepared with an image being formed by a digital halftone image signal.

[0047] The ink supply assembly 16 supplies the re-

spective press plates 28 with inks of the associated colors only at the time when the images of those colors come to the right position during printing. In the embodiment shown in Fig. 2, the assembly 16 comprises four ink supply units 16B, 16C, 16M and 17Y for the four colors B, C, M and Y, respectively. These ink supply units 16 (16B, 16C, 16M and 16Y) are not limited in any particular way and any conventional models known in the art may be used.

[0048] For example, in the case of letterpress and lithography, an ink supply assembly of the type shown in Fig. 4 may be used. In each unit of the assembly, an ink in an ink fountain 58 starts to be supplied from between a duct roller 59 and a bottom plate 60 as the duct roller 59 rotates. The supplied ink is transferred to a transfer roller 61 rotating in contact with the duct roller 59 and the transfer roller 61 as it retains the ink on the surface shifts towards an ink roller train 62 so that the ink is transferred to the first roller of the train 62. As the ink moves to successive rollers of the train 62, it is milled, homogenized and made equal in amount; thereafter one of the applicator rollers 63 (four in number in the case shown in Fig. 4) that contact the press plates 28 only when the images of the associated colors come to the right position is activated so that the ink is deposited evenly in the image area of the right color of a certain press plate 28 formed on the plate cylinder 12. If an image of a different color comes, the irrelevant applicator rollers 63 will be disengaged from the press plate 28. In this way, an ink of the right color can be deposited on the image area of each press plate 28, which image area is either in relief if the plate is for letterpress or an oleophilic area not dampened with water if the plate is for lithography as in the case shown in Fig. 2 (the non-image area has been rendered hydrophilic with dampening water being supplied from the dampening water supply assembly to form a film).

[0049] In an ink supply assembly for intaglio (gravure) printing, highly flowable inks of a solvent-dispersed type are collected in ink trays (not shown) and the plate cylinder 12 is dipped directly in either one of those trays. Alternatively, the inks are deposited on the press plates on the plate cylinder 12 by means of finisher rollers or jet streams of the respective inks are applied directly onto the press plates. Thereafter, excess inks are scraped off with doctor blades so that the remainder is left in minute (gravure) cells that form images.

[0050] As described in the preceding sections, any conventional ink supply assemblies that are known in the art may appropriately be used in accordance with the specific type of the press plate 28. Needless to say, an ink supply assembly for n colors must be employed if press plates for n colors are to be formed.

[0051] The rubber-covered blanket cylinder 18 is a means onto which the ink deposited imagewise on the press plate 28 on the plate cylinder 12 is transferred from the plate 28 and from which it is retransferred onto the printing paper wrapped around the impression cyl-

inder 22. This cylinder is covered with a rubber blanket forming the outermost layer and may be any conventional rubber-covered blanket cylinder that is known in the art. In order to insure that all ink images for four or n colors can be similarly transferred from the press plates 28 around the plate cylinder 12, the blanket cylinder 18 preferably has the same diameter as the plate cylinder 12. However, in order to insure that only an ink image for a single color can be transferred from a press plate on the single plate cylinder 12, the diameter of the blanket cylinder 18 may be a quarter of that of the plate cylinder if the latter is quadruple cylinder or it may be one-nth of the diameter of the plate cylinder if the latter is an n -fold cylinder; of course, other dimensional specifications may be adopted.

[0052] The dampening water supply assembly 20 is a means by which a film of dampening water is always held in the necessary minimum amount to prevent the deposition of ink in the non-image area of a lithographic plate. Usually, the non-image area of a lithographic plate has been rendered hydrophilic so as to permit the deposition of a film of dampening water. In the embodiment shown in Fig. 2, the dampening water supply assembly comprises four units 20B, 20C, 20M and 20Y for the four colors B, C, M and Y, respectively. The dampening water supply unit 20 shown in Fig. 4 comprises a reservoir 64 of dampening water, a water pickup roller 65 for pumping dampening water out of the reservoir 64, a water transfer roller 66 and a water applying roller 67. As it moves to successive rollers of the train, the dampening water that has been pumped out of the reservoir 64 forms a water film of uniform thickness and amount and the applicator roller 67 that contacts a press plate 28 only when an image of that color comes to the right position is activated so that the dampening water is deposited evenly in the non-image area of the right color of the press plate formed on the plate cylinder 12. If an image of a different color comes, the irrelevant applicator roller 67 will be disengaged from the press plate 28. The dampening water supply assembly 20 preferably comprises four units if the plate cylinder 12 is a quadruple cylinder and it preferably comprises n units if the plate cylinder is an n fold cylinder. However, a single dampening water supply assembly may be used in association with a 4 (n)-fold plate cylinder 12. In case of lithographic printing, the above-described roller-type assembly for supplying dampening water may be replaced by various other known types of assembly.

[0053] The impression cylinder 22 is a member around which the printing paper 23 is wrapped and retained in position by a known holder means such as paper grippers and which is to be brought into contact with the blanket cylinder at a predetermined printing pressure so that the ink images carried on the blanket cylinder 18 are transferred onto the printing paper wound around the impression cylinder. If, as in the case under consideration, the press plates 28 formed on the plate cylinder 12 have images of the four colors B, C, M and

Y, the impression cylinder 22 retaining the single sheet of printing paper 23 on the circumference will make four revolutions as the plate cylinder 12 rotates fully once, thereby completing four full-color printing on that printing paper 23. Thereafter, the impression cylinder 22 releases the completed sheet of paper and retains a freshly fed sheet of printing paper. To meet these requirements, the impression cylinder 22 has a diameter which is a quarter of that of the plate cylinder 12 and it rotates in forward direction at the same peripheral speed as the plate cylinder 12. Needless to say, if the plate cylinder 12 is an n-fold cylinder, the diameter of the impression cylinder is one-nth of that of the plate cylinder and it will make $\frac{1}{n}$ revolutions as the plate cylinder rotates fully once.

[0054] The feeder unit 24 supplies the impression cylinder 22 with sheets of printing paper as they are automatically fed one by one from a pile or stack. Although not shown, various conventional automatic sheet feeders known in the art may be used, as operated by a friction method in which a digital element or wheels are pressed against the topmost sheet so as to move it selectively or by a suction method which uses suckers. These methods may be combined with pneumatic, vibrational or otherwise methods of separating sheets. The delivery unit 25 receives printed sheets and stack them one on another in a predetermined position; it may be composed of an automatic or semi-automatic delivery that is known in the art as exemplified by a chain delivery or a pile delivery.

[0055] The original plate supply unit 26 which is disposed within the plate cylinder 12 winds up the spent press plates 28 from its entire circumference while, at the same time, unwinding the unexposed (fresh) original plate 29 onto the entire circumference of the plate cylinder so that it is fixed thereto. The supply unit 26 comprises a takeup roller 68 for winding up the spent press plates 28, an unwinding roller 69 onto which the unexposed original plate 29 has been wound, and means (not shown) for fixing those rollers 68 and 69 in position.

[0056] While details relevant to a printing press according to the present invention have been described above with reference to a typical case where it is used as a lithographic offset press in the presence of dampening water, it should be noted that this is not the sole case of the present invention.

[0057] The models shown in Figures 6, 7 and 8 differ from the structural composition of the press 10 (see Fig. 2) in that the original plate supply unit 26 is omitted and that the original plate 29 is adapted to be mounted on the plate cylinder 12 or dismounted as required. Another difference is that those models lack either one or both of the blanket cylinder 18 and the dampening water supply assembly 26. Since the presses 70, 72 and 74 are completely identical to the press 10 in the other structural aspects, like components are identified by like numerals and will not be described in detail.

[0058] The printing press indicated by 70 in Fig. 6 can

be used not only in letterpress or intaglio but also as a waterless di-litho (direct lithographic) press which does not employ dampening water. It is the same as the press 10 shown in Fig. 1 except that the blanket cylinder 18 and the dampening water supply assembly 20 are omitted so that direct printing is effected as the plate cylinder 12 around which the press plates 28 have been wound is placed in direct contact with the impression cylinder 22 around which the printing paper 23 has been wrapped.

[0059] The printing press indicated by 72 in Fig. 7 can be used as a di-litho press in the presence of dampening water; if the dampening water supply assembly 20 is added to the printing press 70 shown in Fig. 5, the press 72 is obtained and it is capable of printing by direct lithography.

[0060] The printing press indicated by 74 in Fig. 8 is applicable not only to letterpress offset printing and intaglio offset printing but also to waterless lithographic offset printing. It is the same as the printing press 10 shown in Fig. 2 except that it does not include the dampening water supply assembly 20.

[0061] Described hereinabove is the basic construction of a printing press.

[0062] In the next place, the printing press according to the present invention is described below. In this printing press, an unexposed (fresh) original plate (yet to be processed press plates) is wrapped around a single plate cylinder. In n platemaking units of the press, the images of n colors which have typically been subjected to digital processing in n drawing sections are simultaneously written as either latent or visible images in separate colors on the original plate with laser light or the like as it is wrapped around the plate cylinder; then, the images are simultaneously processed in the corresponding n plate processing sections to form press plates on the plate cylinder, whereby press plates are prepared on the surface of which the images of n colors have been correctly written at equal distances, each being one-nth of the circumference of the plate cylinder. As the plate cylinder carrying the press plates for n colors rotates, a plurality of ink supply units for the respective colors that are provided around the plate cylinder will successively supply inks of those colors, with each ink being deposited only at the time when the image of the corresponding color (or the press plate carrying that image) on the plate cylinder has come to the right position. If the press plates are for lithography, dampening water may be supplied to the plates, as required, by means of dampening water supply units before the inks are supplied. As the plate cylinder rotates, the impression cylinder that contacts the plate cylinder either directly or via a rubber-covered blanket cylinder, that has a diameter one-nth of that of the plate cylinder and that holds a single sheet of printing paper wrapped around it rotates in forward direction at the same peripheral speed as the surface of the press plates on the plate cylinder; when the impression cylinder rotates fully

once, the ink image of one color on a press plate on the plate cylinder is transferred onto the printing paper either directly or after it is transferred to the intermediate blanket cylinder. When the impression cylinder has made n revolutions as it holds the printing paper, the plate cylinder rotates fully once and by repeating the transfer step n times, n colors are printed on the paper. When the printing of n colors has been effected in this manner, the impression cylinder releases the paper on which n colors have been printed and holds a freshly supplied sheet of printing paper so that it is subjected to another printing cycle.

[0063] The printing press according to the present invention is simple in construction and compact enough to realize a small-sized system; further, it is capable of simultaneous preparation of press plates for all colors that are needed in accomplishing multicolor printing, whereby the process time from platemaking to printing operations can be shortened; at the same time, the press is easy to operate and enables printing to be done at comparatively high speed. The press is applicable to various types of pressplates whether they are for letterpress, intaglio or lithography (either in the presence or absence of dampening water); at the same time, it is applicable to both direct printing and offset printing. If the press is of such a type that the platemaking units and the ink supply units can be installed alternately, a light-sensitive material such as an electrophotographic photoreceptor or a silver halide photographic material may be mounted on the plate cylinder, with each platemaking unit being composed of a drawing section and a section for processing the light-sensitive material so as to prepare a proof.

[0064] The printing press according to the present invention is described below with reference to the preferred embodiments shown in Figs. 1 and 9 to 12.

[0065] Fig. 1 is a cross-sectional view showing schematically an embodiment of the printing press according to the present invention. As shown, the printing press generally indicated by 80 is a direct process rotary sheet feeding four-color lithographic offset press that uses dampening water and which comprises the following components: a single plate cylinder 12 around which press plates 28 (exposed) for four colors can be formed at given intervals; four platemaking units 14 positioned around and near the plate cylinder 12 that are capable of simultaneous preparation of press plates for four colors; an ink supply assembly 16 for four colors B, C, M and Y; a rubber-covered blanket cylinder 18 onto which ink images are to be transferred from the press plates 28; a dampening water supply assembly 20 for four colors; an impression cylinder 22 whose diameter is one-fourth the diameter of the plate cylinder 12; a feeder unit 24 for supplying the printing paper onto the impression cylinder 22; a delivery unit 25 to be loaded with printed paper; and an original plate supply unit 26 within the plate cylinder 12 by which the spent press plates 28 are wound up whereas an unexposed (fresh)

original plate 29 is unwound.

[0066] The printing press 80 shown in Fig. 1 according to the present invention has the same construction as the printing press 10 shown in Fig. 2, except for the inclusion of four platemaking unit 14s (14B, 14C, 14M and 14Y) for the four colors B, C, M and Y. The same components are identified by likenumerals and will not be described in detail.

[0067] As already mentioned, the plate cylinder 12 is used to position the press plates 28 for the four color B (black), C (cyan), M (magenta) and Y (yellow) on its circumference at given intervals, say, at equal distances. It is particularly required that the plate cylinder 12 be adapted to have the four platemaking units 14 positioned around it so that press plates for the four colors can be prepared simultaneously.

[0068] Each of the platemaking units 14 comprises a drawing section 30, a plate processing section 32 and the platemaking unit loading/unloading device (not shown). To insure that press plates for n colors can be prepared simultaneously, the individual platemaking units 14 are positioned at equal distances (i. e., $360/n$ degrees apart) around the circumference of the plate cylinder 12. In the case shown in Fig. 8, the platemaking assembly 14 comprises four units 14B, 14C, 14M and 14Y for the four colors B, C, M and Y and to insure that press plates for these four colors can be prepared simultaneously, the units are positioned at equal distances (90° out of phase) around the circumference of the plate cylinder 12.

[0069] The platemaking units 14B, 14C, 14M and 14Y are respectively composed of drawing sections 30B, 30C, 30M and 30Y and plate processing sections 32B, 32C, 32M and 32Y. The drawing sections 30B, 30C, 30M and 30Y are the same in construction and so are the plate processing sections 32B, 32C, 32M and 32Y. Hence, a typical embodiment of each platemaking unit of the platemaking assembly 14 is the same as the platemaking unit 14 shown in Fig. 3 which is applied to the printing press 10 shown in Fig. 2 so that it will not be described in detail.

[0070] Such preparation of press plates is accomplished for four colors in the above-described platemaking assembly 14 (composed of four units 14B, 14C, 14M and 14Y), whereby press plates 28 are produced in which images for the four colors B, C, M and Y have been written at equal distances on the circumference of the single plate cylinder 12. In case of printing n colors, an n -fold plate cylinder may be employed to carry press plates 28 in which images for the n colors have been similarly written at equal distances on the circumference by means of the platemaking units 14 which are positioned for the respective colors at equal distances on the circumference.

[0071] The platemaking assembly 14 (14B, 14C, 14M and 14Y) is in no way limited to the case shown in Figs. 2 and 8. As already mentioned, the platemaking assembly 14 (14B, 14C, 14M and 14Y) need not have both the

drawing section 30 (30B, 30C, 30M and 30Y) and the plate processing section 32 (32B, 32C, 32M and 32Y) as shown in Figs. 3 and 1 and, instead, it may solely be composed of the drawing section 30 (30B, 30C, 30M and 30Y). Thus, one may properly select the drawing section 30 (30B, 30C, 30M and 30Y), as well as the plate processing section 32 (32B, 32C, 32M and 32Y) in accordance with the specific type of original plate used and this is the same as already noted in connection with the background art.

[0072] In the second aspect of the present invention, an ink supply assembly typically shown by 16 in Fig. 4 which applied to the printing press 10 shown in Fig. 2 according to the background art may be used as the ink supply assembly and, at the same time, a dampening water supply assembly typically shown by 20 in Fig. 5 may be used as the dampening water supply assembly 20.

[0073] Thus, the printing press 80 shown in Fig. 1 differs from the printing press 10 of Fig. 2 in that the platemaking assembly 14 is composed of four units 14B, 14C, 14M and 14Y. Except for the platemaking process, the printing press 80 shown in Fig. 1 is capable of performing a printing process in essentially the same manner as the printing press 10 shown in Fig. 2.

[0074] In the printing press 80 according to the present invention, the timing of writing onto the fresh original plate 29 on the plate cylinder 12 under exposure to the laser light source 44 in each of the drawing sections 30 (30B, 30C, 30M and 30Y) of the platemaking units 14 (14B, 14C, 14M and 14Y) is adjusted to become synchronous with not only the fast scan (main scanning) but also the slow scan (subscanning) as effected by the rotation of the plate cylinder 12 per se; as a result, the positions of writing images of the four colors B, C, M and Y onto the original plate 29 around the plate cylinder 12 are set correctly, thereby enabling the preparation of press plates in which those images have been written with correct registry at equal distances on the circumference of the single plate cylinder 12. Therefore, the printing press 80 requires no registration even in multi-color printing and it can be operated even by unskilled operators, which will potentially lead to printing operations with reduced man-power.

[0075] If necessary, the printing press 80 according to the present invention may be equipped with a device for achieving registration between individual colors, say, B, C, M and Y.

[0076] While the printing press according to the present invention has been described above with reference to a typical case where it is used as a lithographic offset press in the presence of dampening water, it should be noted that this is not the sole case of the present invention and that the printing press indicated by 82 in Fig. 9, the press indicated by 84 in Fig. 10 and the press indicated by 86 in Fig. 11 are also included within the structural scope of the printing press according to the present invention. These models differ from

the structural composition of the press 80 (see Fig. 1) in that the original plate supply unit 26 is omitted and that the original plate 29 is adapted to be mounted on the plate cylinder 12 or dismounted as required. Another difference is that those models lack either one or both of the blanket cylinder 18 and the dampening water supply assembly 26. Since the presses 82, 84, and 86 are completely identical to the press 80 in the other structural aspects, like components are identified by like numerals and will not be described in detail.

[0077] The printing press indicated by 82 in Fig. 9 can be used not only in letterpress or intaglio but also as a waterless di-litho (direct lithographic) press which does not employ dampening water. It is the same as the press 80 shown in Fig. 1 except that the blanket cylinder 18 and the dampening water supply assembly 20 are omitted, so that direct printing is effected as the plate cylinder 12 around which the press plates 28 have been wound is placed in direct contact with the impression cylinder 22 around which the printing paper 23 has been wrapped.

[0078] The printing press indicated by 84 in Fig. 10 can be used as a di-litho press in the presence of dampening water; if the dampening water supply assembly 20 is added to the printing press 82 shown in Fig. 9, the press 84 is obtained and it is capable of printing by direct lithography.

[0079] The printing press indicated by 86 in Fig. 11 is applicable not only to letterpress offset printing and intaglio offset printing but also to waterless lithographic offset printing. It is the same as the printing press 80 shown in Fig. 1 except that it does not include the dampening water supply assembly 20.

[0080] Fig. 12 shows a printing press 88 which is another embodiment of the present invention; as shown, not only the platemaking unit 14 composed of the drawing section 30 and the plate processing section 32 but also the ink supply unit 16 is adapted to be movable in a direction parallel to the central axis of the plate cylinder 12 (i.e., the direction indicated by arrow A).

[0081] In direct platemaking for digital images, the platemaking section 14 is positioned correctly on the original plate 29 around the plate cylinder 12 and the image of a relevant color is written by means of the drawing section 30 and subjected to development and any other necessary processes by the plate processing section 32 so as to prepare a press plate 28 carrying that image. Subsequently, the platemaking unit 14 composed of the drawing section 30 and the plate processing section 32 is moved by means of a moving mechanism (not shown) in the direction of arrow A so that it is removed from above the press plate 28. At the same time, the ink supply unit 16 is slid above the press plate 28 by means of a moving mechanism (also not shown), located in the correct position and actuated to supply an ink of a relevant color for the press plate carrying the image at issue. The individual images as supplied with inks in the manner described above are formed in su-

perposition on the printing paper so as to achieve multicolor printing.

[0082] Fig. 12 shows only the platemaking unit 14 and the ink supply unit 16 for a single color but it goes without saying that in the actual printing process, the platemaking units 14 for n colors and the ink supply units 16 for n colors are used in such a way that the former are alternately replaced positionally at a time by the latter with respect to all n colors. The mechanisms (the loading/unloading devices) for moving the platemaking unit 14 and the ink supply unit 16 are not shown in Fig. 15 but they are not limited in any particular way and may be in the form of physically independent devices or in such a form that they are made integral with each other either partly or in entirety.

[0083] In another embodiment of the printing press 88 in which both the platemaking unit 14 and the ink supply unit 16 are movable, the plate cylinder 12 covered with the original plate 29 may be used either as a cylindrical drum of electrophotographic photoreceptor having a photoconductive layer on the top or as an exposure drum covered with a light-sensitive material (e.g. an electrophotographic photoreceptor, a silver halide photographic material, a photo-sensitive resin material) or a pressure-sensitive resin material whereas the impression cylinder is used as a transfer drum, so that the images formed are successively transferred onto the image-receiving sheet around the transfer drum, thereby producing a proof carrying a color image. In other words, the printing press 88 can also be used as an image forming apparatus for proofing if the ink supply unit 16 is not employed. The light-sensitive material and the image-receiving sheet that are to be used in this embodiment are not limited in any particular way and may be selected from among any types that are known in the art.

[0084] Thus described hereinabove is the basic construction of the printing press according to the present invention.

[0085] While the printing press of the present invention has been so far described it should be noted that the invention is by no means limited to those cases and that various improvements and design modifications can be made without departing from the scope of the invention as defined by the appended claims; for example, the press may be furnished with various additional members or devices such as a dryer for drying the ink transferred onto the printing paper, as well as a blade or cleaner for removing ink from the rubber-covered blanket cylinder to which it has been transferred.

[0086] The printing press according to the second aspect of the present invention performs printing in n colors by repeating the process comprising the following steps: writing correctly the images of n colors simultaneously at equal distances on the circumference of an unexposed (fresh) original plate (yet to be processed press plates) wrapped around a single plate cylinder; processing the original plate to form press plates; de-

positing inks of the respective colors successively on the images on the corresponding press plates; and transferring the ink images onto the printing paper held on the impression cylinder. The press has the advantage that it is capable of preparing press plates for multiple colors within a time period that corresponds to a single color and this effectively shortens the overall process time from the platemaking to printing operations. As a result, the press will potentially enable printing operations to be done with reduced man-power.

[0087] In summary, the printing press of the present invention uses a smaller number of printing cylinders than the prior art multicolor presses and, hence, it is sufficiently simple in construction and small-sized to require a smaller space for installation. A further advantage of the present invention is that it is capable of accomplishing printing operations up to comparatively high speed. The printing press of the invention is applicable to various types of press plates whether they are for letterpress, intaglio or lithography (either in the presence or absence of dampening water); at the same time, it is applicable to both direct printing and offset printing.

25 Claims

1. A multi-color printing press that comprises a single plate cylinder (12) that allows press plates (28) for n colors (B,C,M,Y) to be disposed cylindrically at predetermined intervals, an impression cylinder (22) whose diameter is one-nth of that of said plate cylinder (12), said impression cylinder (22) having a single sheet of printing paper (23) wrapped around it and delivering said printing paper (23) after it has made n consecutive revolutions, and an ink supply assembly (16) for the n colors (B,C,M,Y) **characterized by** n platemaking units (14M,14C,14B,14Y) which are disposed around the circumference of said plate cylinder (12) and near the plate cylinder (12) for individually preparing press plates (28) for single colors.
2. A multi-color printing press according to claim 1, wherein said platemaking units (14M,14C,14B,14Y) and said ink supply assembly (16) are both movable in a direction parallel to the central axis of said plate cylinder (12) so that they are alternately located in the same position over said plate cylinder (12).
3. A multi-color printing press according to claim 1 or 2, wherein each of said platemaking units (14M,14C,14B,14Y) comprises a drawing section (30M,30C,30B,30Y) that writes an image on an unexposed original plate (29) wound onto said plate cylinder (12) and a plate processing section (32M,32C,32B,32Y) that processes said original plate (29) to prepare a press plate (28).

4. A multi-color printing press according to claim 3, wherein said original plate (29) is a light-sensitive material.
5. A multi-color printing press according to claim 3, wherein said original plate (29) is an electrophotographic photoreceptor.
6. A multi-color printing press according to any one of claims 3 to 5, wherein said drawing section (30M, 30C, 30B, 30Y) is composed of a laser exposing unit.
7. A multi-color printing press according to any one of claims 3 to 6, wherein said plate processing section (32M, 32C, 32B, 32Y) is composed of a wet developing unit.
8. A multi-color printing press according to any one of claims 1 to 7, which further includes an original plate supply mechanism (26) within said plate cylinder (12), said mechanism winding up the plate (28) with which a printing process has been completed and unwinding an unexposed original plate (29).
9. A multi-color printing press according to any one of claims 1 to 8, which further includes an ink transfer blanket cylinder (18) between said plate cylinder (12) and said impression cylinder (22).
10. A multi-color printing press according to claim 9, wherein said blanket cylinder (18) has the same diameter as said plate cylinder (12) or said impression cylinder (22).
11. A multi-color printing press according to any one of claims 1 to 10, wherein said press plate (28) is for letterpress, intaglio or lithography.
12. A multi-color printing press according to claim 11, which uses a lithographic plate as said press plate (28) and which further includes a dampening water supply assembly for supplying dampening water to said press plate (28).
- nung (16) für die n- Farben (B, C, M, Y), **gekennzeichnet durch** n- Plattenherstellungseinheiten (14M, 14C, 14B, 14Y), die um den Umfang des Plattenzylinders (12) herum und nahe des Plattenzylinders (12) in gleichen Abständen zum individuellen Vorbereiten von Preßplatten (28) für einzelne Farben angeordnet sind.
2. Mehrfarbdruckerpresse nach Anspruch 1, wobei die Plattenherstellungseinheiten (14M, 14C, 14B, 14Y) und die Farbstoffzuführungsanordnung (16) beide in einer Richtung parallel zu der zentralen Achse des Plattenzylinders (12) bewegbar sind, so daß sie abwechselnd in derselben Position über dem Plattenzylinder (12) angeordnet sind.
3. Mehrfarbdruckerpresse nach Anspruch 1 oder 2, wobei jede der Plattenherstellungseinheiten (14M, 14C, 14B, 14Y) einen Zeichnungsabschnitt (30M, 30C, 30B, 30Y) aufweist, der ein Bild auf eine um den Plattenzylinder (12) herum gewundene, unbelichtete Originalplatte (29) zeichnet, und einen Plattenverarbeitungsabschnitt (32M, 32C, 32B, 32Y) aufweist, der die Originalplatte (29) verarbeitet, um eine Preßplatte (28) vorzubereiten.
4. Mehrfarbdruckerpresse nach Anspruch 3, wobei die Originalplatte (29) ein lichtempfindliches Material ist.
5. Mehrfarbdruckerpresse nach Anspruch 3, wobei die Originalplatte (29) ein elektrofotografischer Fotorezeptor ist.
6. Mehrfarbdruckerpresse nach irgendeinem der Ansprüche 3 bis 5, wobei der Zeichnungsabschnitt (30M, 30C, 30B, 30Y) aus einer Laserexpositions-einrichtung zusammengesetzt ist.
7. Mehrfarbdruckerpresse nach irgendeinem der Ansprüche 3 bis 6, wobei der Plattenverarbeitungsabschnitt (32M, 32C, 32B, 32Y) aus einer Naßentwicklungseinheit zusammengesetzt ist.
8. Mehrfarbdruckerpresse nach irgendeinem der Ansprüche 1 bis 7, die außerdem eine Originalplatten-zuführungsvorrichtung (26) innerhalb des Plattenzylinders (12) enthält, wobei die Vorrichtung die Platte (28), mit der ein Druckverfahren ausgeführt worden ist, aufwickelt und eine unbelichtete Originalplatte (29) abwickelt.
9. Mehrfarbdruckerpresse nach irgendeinem der Ansprüche 1 bis 8, die außerdem einen Farbstofftransferdruckzylinder (18) zwischen dem Plattenzylinder (12) und dem Einpreßzylinder (22) enthält.
10. Mehrfarbdruckerpresse nach Anspruch 9, wobei

Patentansprüche

1. Mehrfarbdruckerpresse, die einen einzelnen Plattenzylinder (12) aufweist, der Preßplatten (28) für n Farben (B, C, M, Y) ermöglicht, zylinderförmig in vorbestimmten Intervallen angeordnet zu werden, einen Einpreßzylinder (22), dessen Durchmesser ein n-tel von demjenigen des Plattenzylinders (12) ist, wobei der Einpreßzylinder (22) einen einzelnen Bogen von Druckpapier (23), der um diesen gewickelt ist, aufweist, und das Druckpapier (23) austrägt, nachdem es n aufeinanderfolgende Umläufe ausgeführt hat und eine Farbstoffzuführungsanord-

der Farbstofftransferdruckzylinder (18) denselben Durchmesser wie der Plattenzylinder (12) oder der Einpreßzylinder (22) hat.

11. Mehrfarbdruckerpresse nach irgendeinem der Ansprüche 1 bis 10, wobei die Preßplatte (28) für Letterdruck, Tiefdruck oder Lithographie vorgesehen ist. 5
12. Mehrfarbdruckerpresse nach Anspruch 11, die eine Litographieplatte als die Preßplatte (28) verwendet, und die außerdem eine Zuführungsanordnung für benetzendes Wasser zum Zuführen von benetztem Wasser zu der Preßplatte (28) enthält. 10

Revendications

1. Presse d'impression en couleurs qui comporte un seul cylindre porte-clichés (12) qui permet la disposition de clichés d'impression (28) pour n couleurs (B, C, M, Y) sous forme cylindrique à des intervalles prédéterminés, un cylindre d'impression (22) dont le diamètre est égal à 1/n fois celui du cylindre porte-clichés (12), le cylindre d'impression (22) ayant une feuille unique de papier d'impression (23) enroulée sur lui et transmettant la feuille de papier d'impression (23) après qu'elle a effectué n tours consécutifs, et un ensemble de transmission d'encre (16) des n couleurs (B, C, M, Y), **caractérisé par** n ensembles de fabrication de clichés (14M, 14C, 14B, 14Y) qui sont disposées à la circonférence du cylindre portecliches (12) et près du cylindre porte-clichés (12) pour la préparation individuelle de clichés d'impression (28) pour les couleurs séparées. 20
2. Presse d'impression en couleurs selon la revendication 1, dans laquelle les ensembles de fabrication de clichés (14M, 14C, 14B, 14Y) et l'ensemble de transmission d'encre (16) sont mobiles tous deux en direction parallèle à l'axe central du cylindre porte-clichés (12) afin qu'ils soient disposés en alternance dans la même position audessus du cylindre porte-clichés (12). 25
3. Presse d'impression en couleurs selon la revendication 1 ou 2, dans laquelle chacun des ensembles de fabrication de clichés (14M, 14C, 14B, 14Y) comporte une section de dessin (30M, 30C, 30B, 30Y) qui écrit une image sur un cliché original non exposé (29) enroulé sur le cylindre porte-clichés (12) et une section de traitement de cliché (32M, 32C, 32B, 32Y) qui traite le cliché original (29) pour la préparation d'un cliché d'impression (28). 30
4. Presse d'impression en couleurs selon la revendication 3, dans laquelle le cliché original (29) est for- 35

mé d'un matériau photosensible.

5. Presse d'impression en couleurs selon la revendication 3, dans laquelle le cliché original (29) est un photorécepteur électrophotographique. 40
6. Presse d'impression en couleurs selon l'une quelconque des revendications 3 à 5, dans laquelle la section de dessin (30M, 30C, 30B, 30Y) est composée d'un ensemble d'exposition par un laser. 45
7. Presse d'impression en couleurs selon l'une quelconque des revendications 3 à 6, dans laquelle la section de traitement de cliché (32M, 32C, 32B, 32Y) est composée d'un ensemble de développement de type humide. 50
8. Presse d'impression en couleurs selon l'une quelconque des revendications 1 à 7, qui comporte en outre un mécanisme de transmission de cliché original (26) dans le cylindre porte-clichés (12), le mécanisme enroulant le cliché (28) avec lequel une opération d'impression a été terminée et déroulant un cliché original non exposé (29). 55
9. Presse d'impression en couleurs selon l'une quelconque des revendications 1 à 8, qui contient en outre un cylindre porte-blanchet de report d'encre (18) placé entre le cylindre porte-clichés (12) et le cylindre d'impression (22).
10. Presse d'impression en couleurs selon la revendication 9, dans laquelle le cylindre porte-blanchet (18) a le même diamètre que le cylindre porte-clichés (12) ou le cylindre d'impression (22).
11. Presse d'impression en couleurs selon l'une quelconque des revendications 1 à 10, dans laquelle le cliché d'impression (28) est destiné à une impression typographique, en creux ou lithographique.
12. Presse d'impression en couleurs selon la revendication 11, qui utilise le cliché lithographique comme cliché d'impression (28) et qui comprend en outre un ensemble d'alimentation en eau de mouillage pour la transmission d'eau de mouillage au cliché d'impression (28).

FIG.1

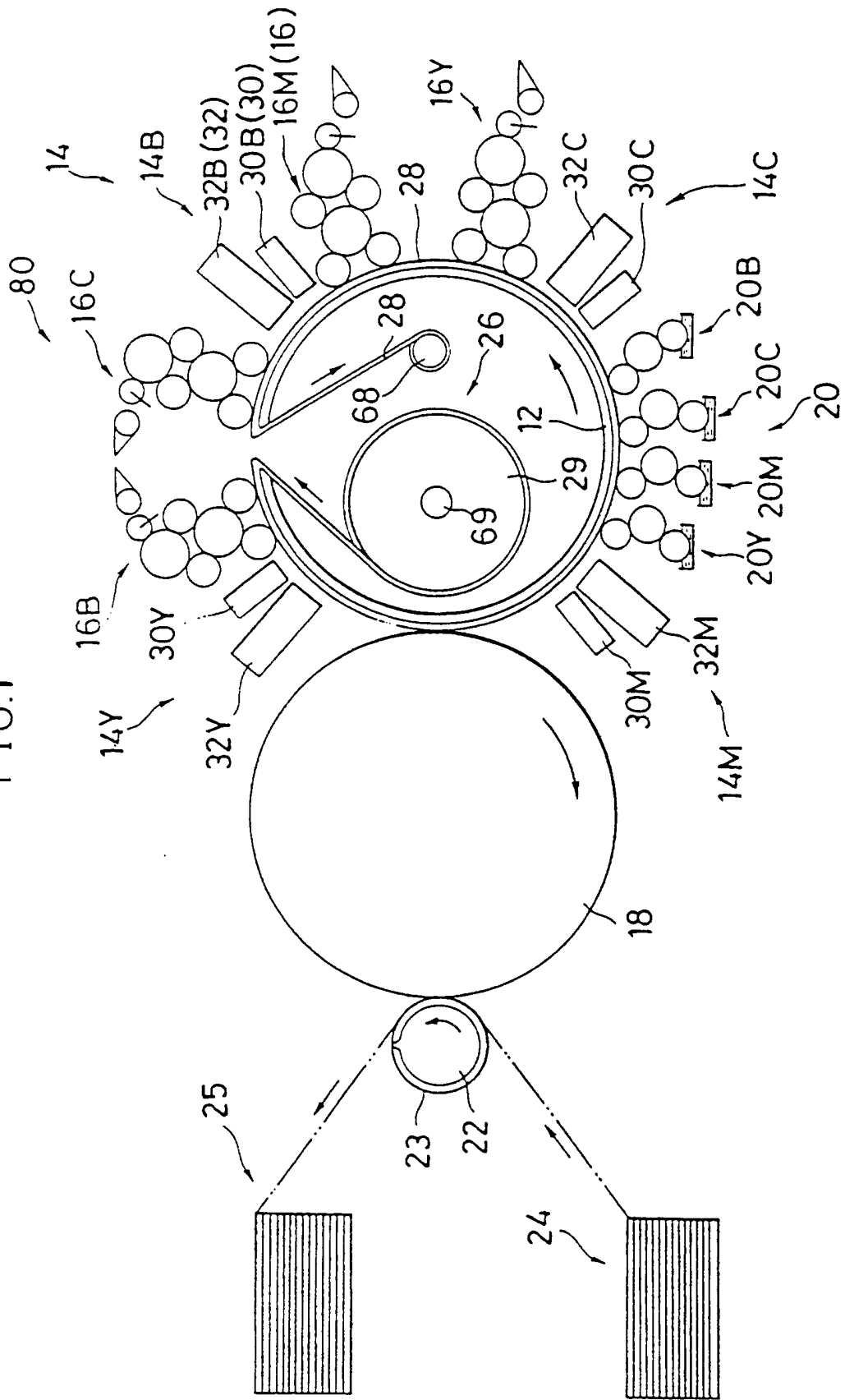

FIG. 2

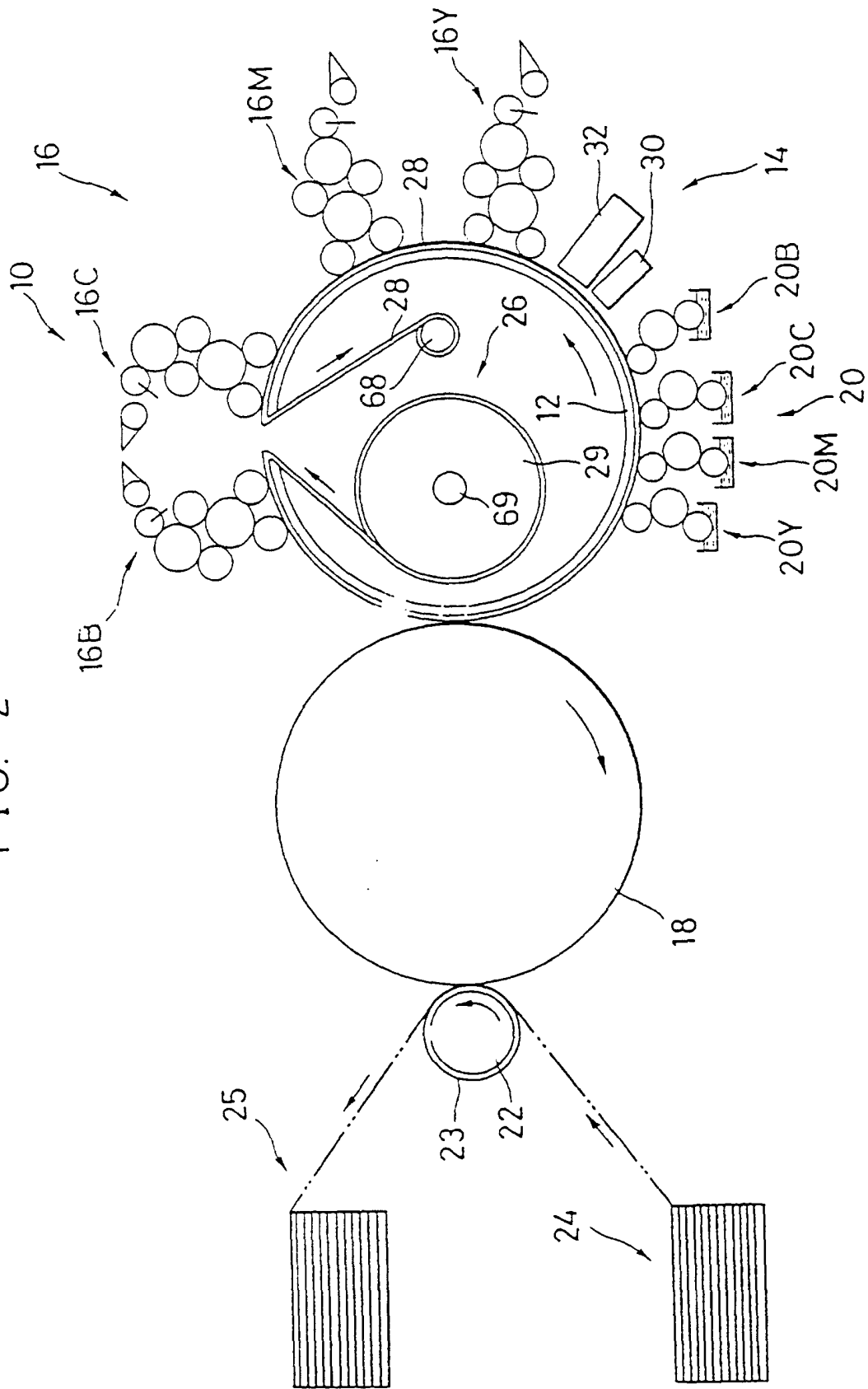

FIG. 3

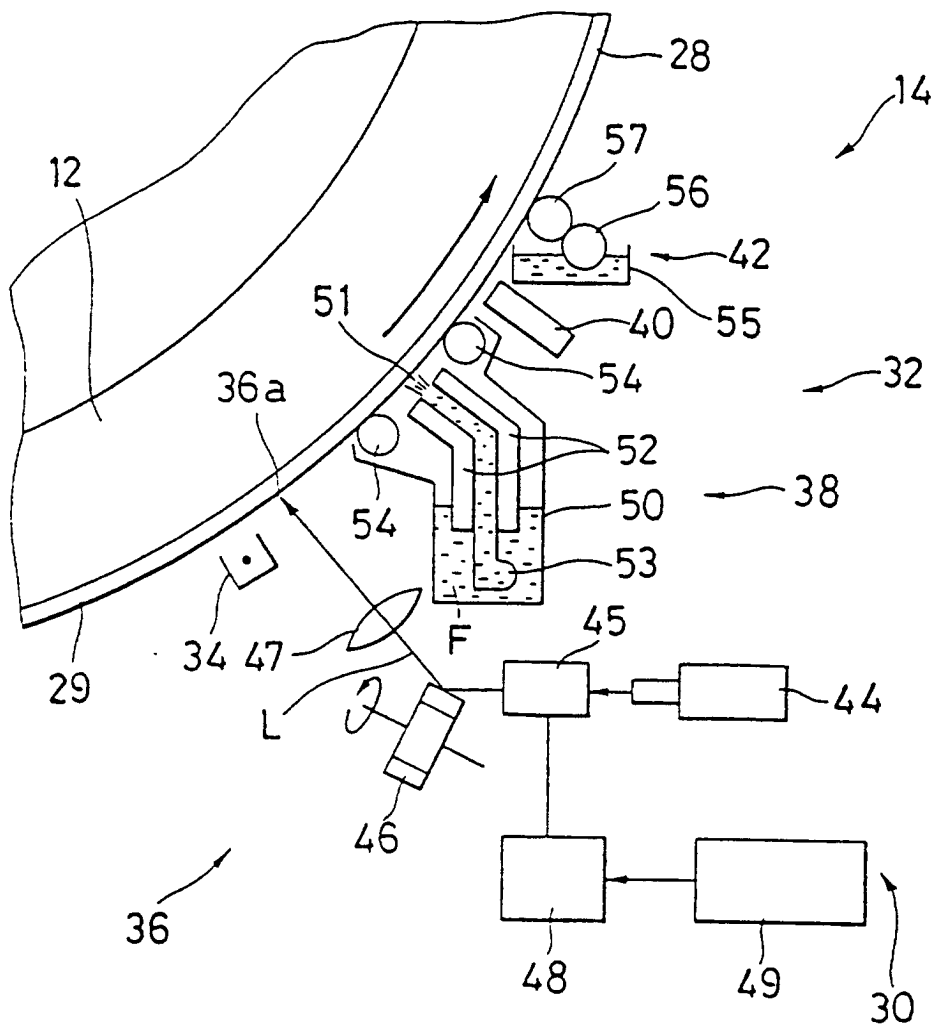

FIG. 4

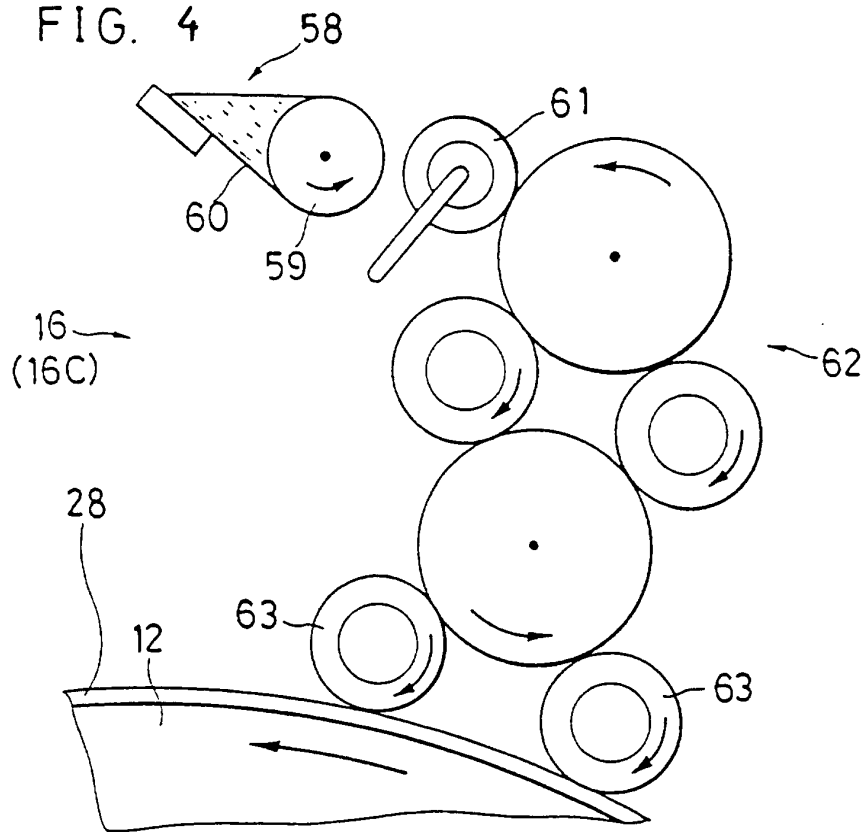

FIG. 5

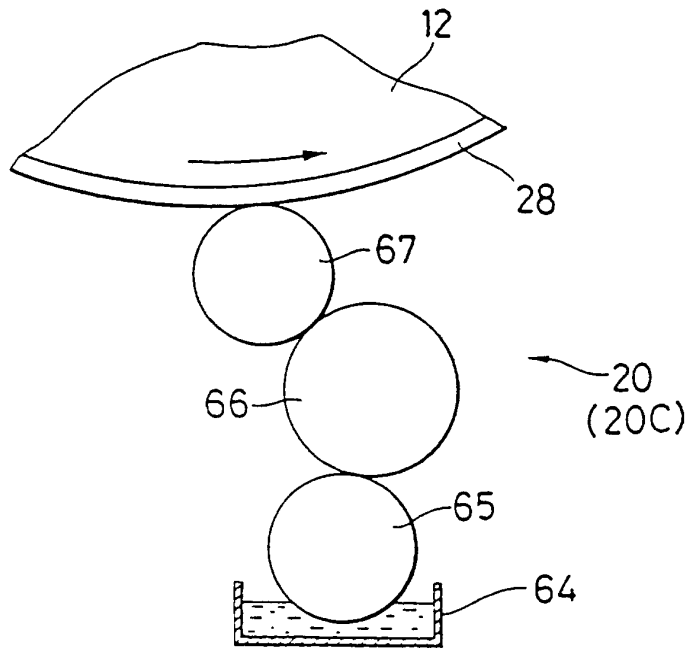

FIG. 6

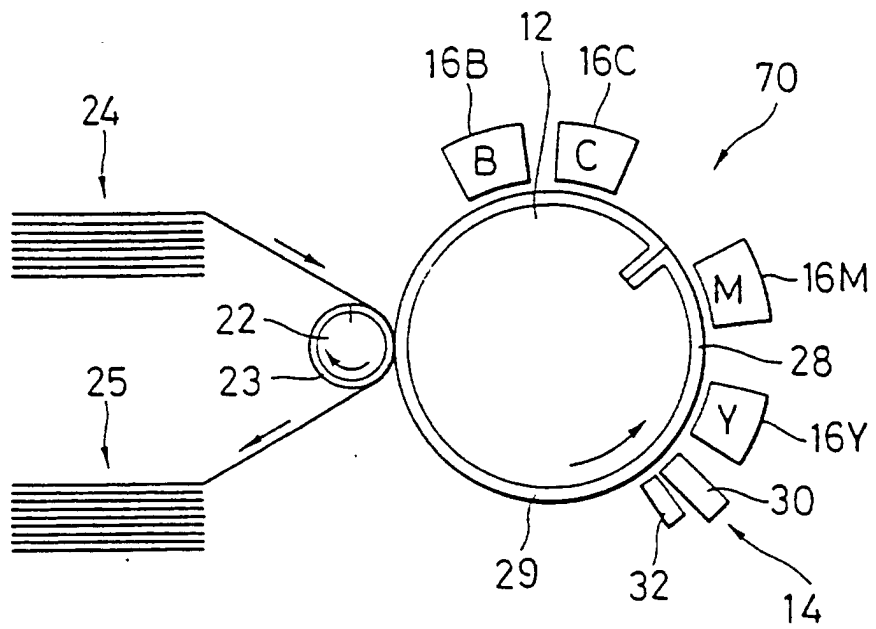

FIG. 7

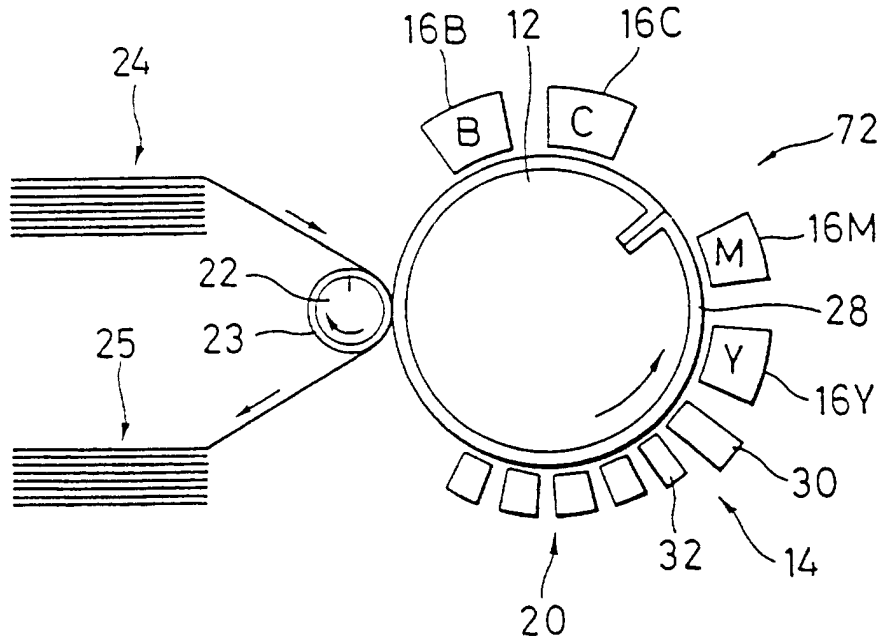

FIG. 8

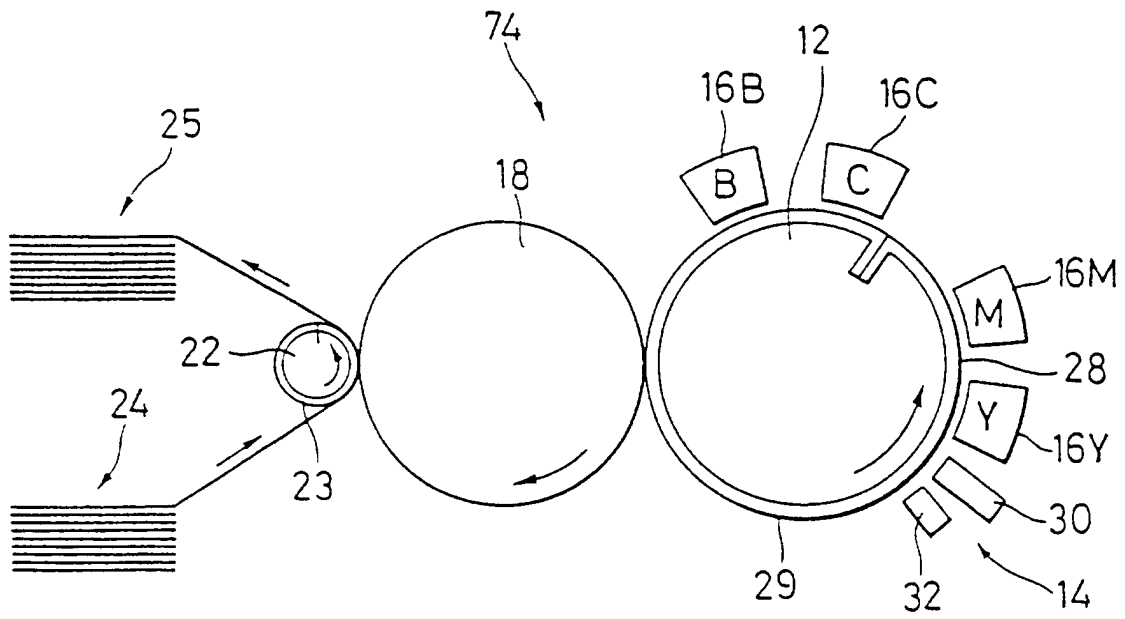

FIG. 9

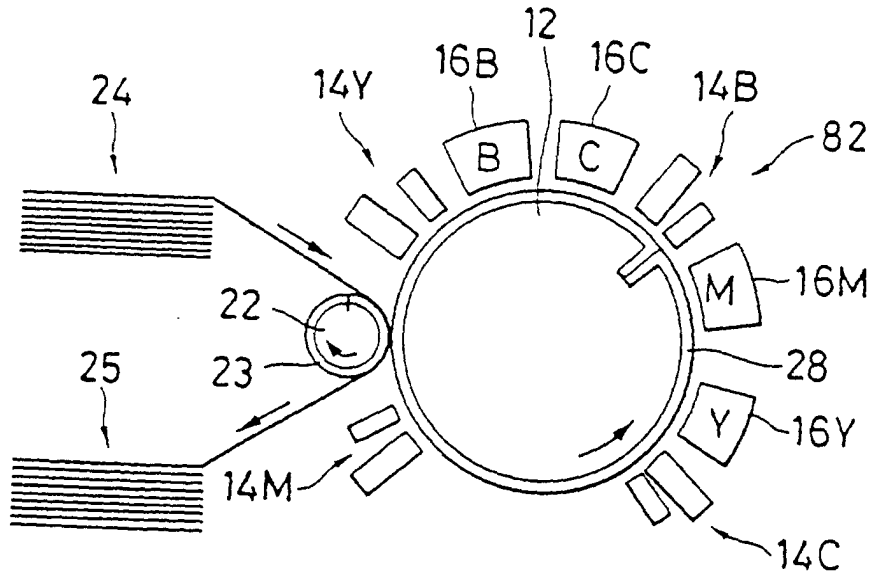

FIG. 10

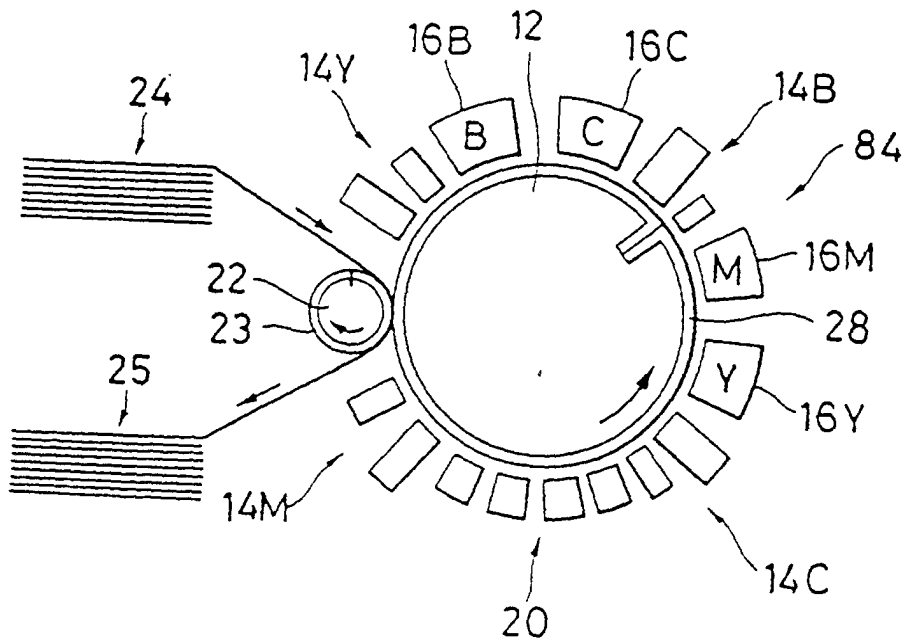

FIG. 11

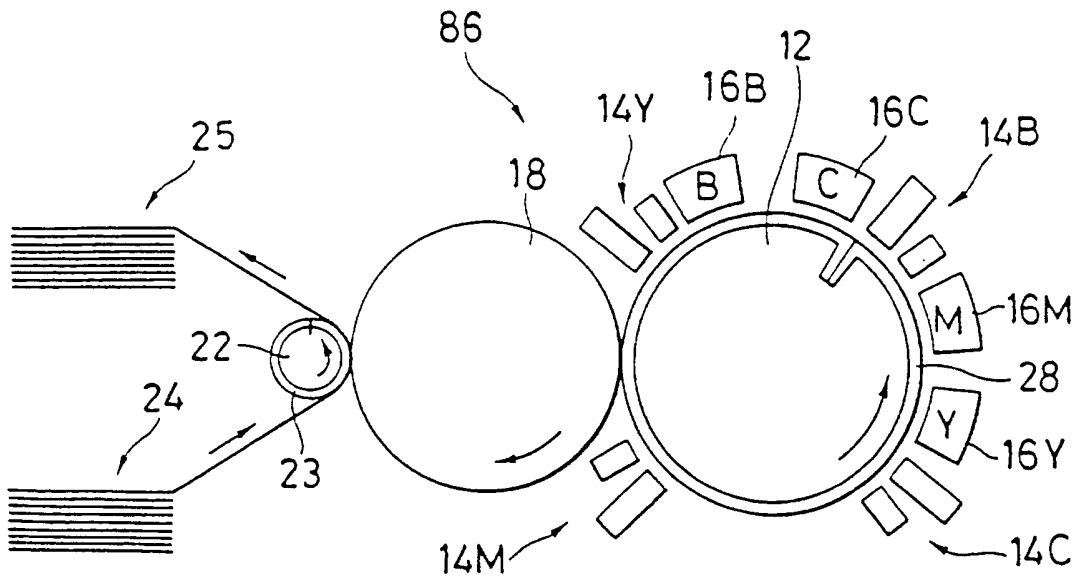

FIG. 12

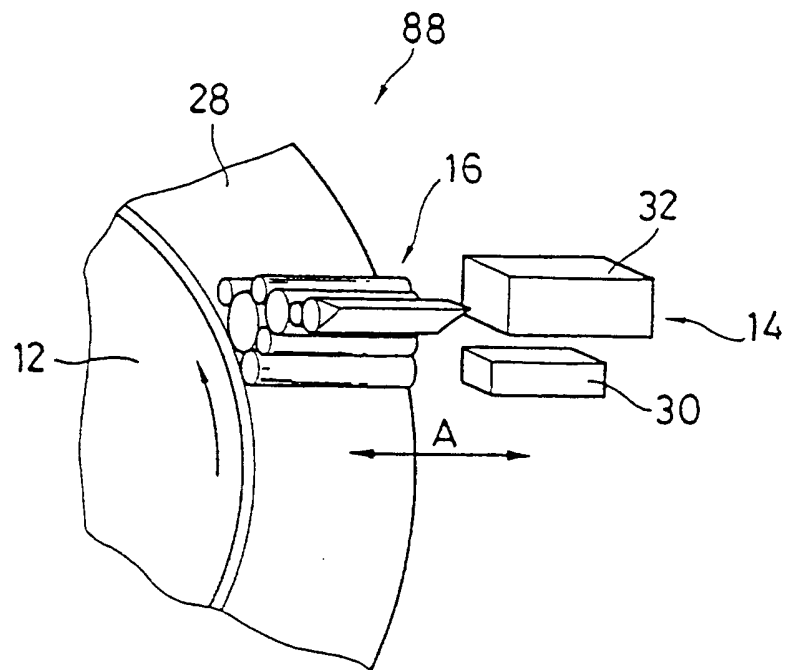

FIG. 13

