



Europäisches Patentamt  
European Patent Office  
Office européen des brevets



Publication number: **0 512 615 A1**

**EUROPEAN PATENT APPLICATION**

Application number: **92201200.0**

Int. Cl.<sup>5</sup>: **A47B 88/04, A47B 88/10**

Date of filing: **29.04.92**

Priority: **02.05.91 NL 9100758**

Inventor: **Wojcik, Hendricus Tadeusz**  
**Lindelaan 12**  
**NL-6245 JS Eijsden(NL)**

Date of publication of application:  
**11.11.92 Bulletin 92/46**

Designated Contracting States:  
**AT BE CH DE DK ES FR GB IT LI NL PT SE**

Representative: **Smulders, Theodorus A.H.J.,**  
**Ir. et al**  
**Vereenigde Octroobureaux Nieuwe Parklaan**  
**97**  
**NL-2587 BN 's-Gravenhage(NL)**

Applicant: **Thomas Regout N.V.**  
**Industrieweg 40**  
**NL-6219 NR Maastricht(NL)**

**Anti-rack system for drawers.**

A suspension frame type drawer (1) with an anti-rack system, provided with telescopic guides (10) consisting of a drawer section (11) connected to the drawer (1), a central section (12) and a cabinet section (13) to be housed in a cabinet surrounding the drawer (1) and provided with a rack (14). Mounted to the drawer (1) is a shaft (7) carrying on both sides gear wheels (8) engaging the racks (14). The

racks (14) are equipped with a tiltable extension piece (16) having teeth (19). When the drawer (1) is completely pulled out of the cabinet, the gear wheels (8) continue to engage the extended racks (14), so that the anti-racking effect is retained in that position. When pushing in the drawer (1), the extension piece (16) is tilted about its pivot (20).

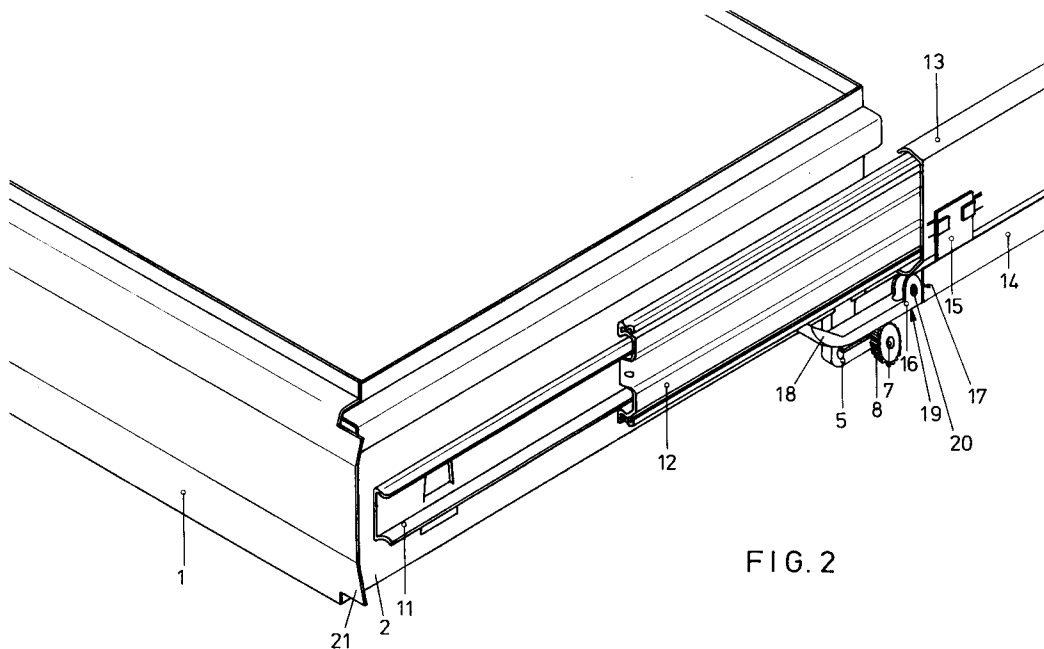

FIG. 2

EP 0 512 615 A1

This invention relates to a slidable drawer provided on both sides with a telescopic guide consisting of a drawer section, a central section and a cabinet section, each cabinet section being provided with a rack engaging a gear wheel connected to the drawer and mounted on a shaft.

Slidable drawers provided with a telescopic guide are known in many types and are often used in desks, cabinets and other filing systems. The drawer itself is usually a product of rigid shape, consisting of four sides and a bottom. If the width of the drawer relative to the depth is very large and, moreover, the drawer has no bottom, as is the case with suspension frames for filing three rows of suspension files side by side, there is a great chance that, for instance when an opened drawer is moved in, this drawer becomes forced out of alignment in regard to the telescopic sections, resulting in that the closing of the drawer is impeded owing to racking of the drawer in respect of the guide sections. To prevent this racking, it is known to provide the drawer on the two sides with gear wheels engaging associated racks. The meshing of the two racks with the gear wheels ensures that the drawer cannot be forced out of alignment in regard to the telescopic guides and that, therefore, the opening and closing movements always remain parallel to the main direction of the telescopic guides arranged on both sides of the drawer.

It is desirable that a drawer can be moved so far out of the cabinet surrounding the drawer that the rear end of the drawer is accessible. This is particularly desirable in case of suspension frames for keeping suspension files, because otherwise the rearmost suspension files of a row cannot be taken out or placed back in the suspension frame. This desired property of drawers is usually designated by the term "overtravel". Telescopic guides allowing such overtravel are known per se. However, the combination of an overtravel drawer with an anti-rack system gives problems for the following reasons.

In an overtravel drawer the rear end of the drawer is, as discussed above, outside the cabinet surrounding the drawer. The gear wheels connected to this drawer must continue to engage the racks arranged in the cabinet, because otherwise the anti-racking effect would be lost when the drawer is completely pulled out, while the anti-racking effect is important in that particular position of the drawer. Therefore, in the opening direction the gear wheels connected to the drawer must be arranged at some distance from the rear end of the drawer. When the drawer is pushed in, there must be room enough within the cabinet surrounding the drawer for the gear wheels present behind the rear end and this means that behind the completely closed drawer a void space must be present in the cabinet

for receiving these gear wheels projecting backwards. Such a void space is of course a lost space, which is undesirable for reasons of efficiency.

It is an object of this invention to provide a drawer which is equipped with an anti-rack system and is, moreover, of the "overtravel" type, while in the closed position the rear end of the drawer substantially abuts against the rear of a cabinet surrounding the drawer. This object is achieved according to the invention in that in a slidable drawer of the above type each rack is provided on the pulling side of the cabinet section with a tiltable extension piece connected to the rack and having teeth, which extension piece can be brought into the lowered position when pulling out the drawer and into the raised position when pushing in the drawer.

Thus the fixed racks present within the cabinet have been provided with a portion projecting beyond the cabinet, which portion can be continuously engaged by the gear wheels connected to the drawer when this drawer is completely pulled out, so that the anti-racking effect is also retained in the completely opened position of the drawer. When pushing in the drawer, these extended racks are brought into a raised position by the drawer itself, so that in the closed position the drawer can be completely housed in the cabinet.

In addition to the above solution to the problem set, there is also another solution in which the gear wheel engaging the rack is housed in a gearbox with three intermeshing gear wheels, two of which can mesh with the rack, which gearbox is tiltably mounted in regard to the drawer.

This second solution according to the invention actually means that the gear wheels of the anti-rack system project behind the rear end of the drawer, but are tilted under the bottom face of the drawer, so that in this solution, too, the rear end of the drawer in the completely closed position practically abuts against the rear wall of the cabinet housing the drawer.

The above-described embodiments of the drawer according to the invention will hereinafter be explained with reference to the accompanying drawings, in which

Fig. 1 is a perspective side view of the rear end of a drawer and the telescopic guide to be connected therewith, provided with a rack;

Fig. 2 shows a drawer in completely opened position, likewise in perspective view;

Figs. 3-5 are side views of a drawer according to the invention in respectively completely opened position (Fig. 3), substantially closed (Fig. 4) and completely closed or housed position (Fig. 5); and

Figs. 6-8 are side views according to Figs.3-5 of a second embodiment of the drawer according

to the invention.

Referring to Fig. 1, there is shown a corner 4 of a rear end of a suspension frame type drawer 1, in which corner 4 a side wall 2 and a rear end 3 of the drawer 1 are interconnected in any suitable manner. In the corner a fastening block 5 usually made of plastic material is disposed on the side wall 2 of drawer 1. This fastening block 5 serves to include a slide block 6 supporting a shaft 7. Disposed on the end of shaft 7 is a gear wheel 8 projecting beyond the plane of side wall 2. The fastening block 5 is preferably provided with a horizontal slot 9, which can be more or less closed by means of an adjusting screw, not shown, for adjusting the gear wheel 8 to the correct height.

Over the drawer 1 there is shown a telescopic guide 10 consisting of a drawer section 11, which, as indicated by arrows P, is secured to the side wall 2 of drawer 1. The telescopic guide 10 further comprises a central section 12 and a cabinet section 13, on the underside of which a rack 14 is disposed by means of clamping blocks 15. The cabinet section 13 is intended to be mounted to the inner wall of a cabinet (not shown), in which the drawer 1 can be arranged. The rack 14 may of course also be mounted to the top side of cabinet section 13. In that case the shaft 7 and the gear wheels 8 mounted thereon are of course secured to the top side of drawer 1.

Referring to Figs. 2-5, there is shown the anti-rack system according to the invention, in which, in Fig. 2, the suspension frame 1 is in the completely opened position and the drawer section 11 is completely pulled out of the cabinet section 13. The two sections 11, 13 remain interconnected by means of the central section 12. The rack 14 disposed on the underside of cabinet section 13 is provided with an extension piece 16, the bottom face of which is provided with teeth 19, which, in the position shown, are in the same principal plane as the teeth of rack 14. The extension piece 16 is tiltably mounted on a pivot 20, which is suitably connected to the end of rack 14. The extension piece 16 is provided with a stop face 17 ensuring that in the completely lowered position of extension piece 16 the teeth 19 thereof mesh with those of rack 14. The gear wheel 8 mounted on the shaft 7 engages the teeth 19 of extension piece 16 and is outside the cabinet not shown, the front of which is at some distance from the end of cabinet section 13.

The front of extension piece 16 is provided with a curved end 18, the function of which will be explained hereinafter.

Referring to Figs. 3-5, the drawer 1 is shown in three different positions. In the completely opened position (Fig. 3) the gear wheel 8 is outside the front end of cabinet section 13 and engages the

teeth 19 of extension piece 16. The curved end 18 of extension piece 16 abuts against the bottom face of central section 12.

When pushing in the suspension frame 1, the gear wheel rolls over the extension piece 16 kept in a fixed position and then over the teeth of rack 14. When the suspension frame 1 is moved over some distance to the left, the bottom face of the central portion 12 has passed the curved end 18 of extension piece 16. When pushing in the suspension frame 1 further, the curved end 18 abuts against a laterally projecting edge 21 of suspension frame 1 and the extension piece 16 is tilted about the pivot 20 in the upward direction. In the completely closed position of the suspension frame 1 the gear wheel 8 is near the rear wall, not shown, of the cabinet and the extension piece 16 is raised through 90°.

When pulling out the suspension frame 1, the extension piece 16 is brought into the lowered position by the central portion 12 and kept in that position.

Referring to Figs. 6-8, there is shown a second embodiment of the drawer according to the invention, the same reference numerals as in Figs. 3-5 being used for corresponding parts. The gear wheel 28 foremost in the opening direction R is mounted on a stud 27, which is connected to the suspension frame 1 in the same manner as shown in Fig. 1. The gear wheel 28 is included in a gearbox 32, which further contains the gear wheels 33 and 34. The gear wheel 33 can mesh with the rack 14, as can the gear wheel 28. The gear wheel 34 engages the two gear wheels 33, 28 and only serves to synchronize the movement of these gear wheels 33, 28. The gearbox 32 may consist of a bearing plate pivotable on stud 27.

The gear wheel 28 is arranged in front of the rear face of suspension frame 1, seen in the opening direction. In the completely opened position of suspension frame 1, the gear wheel 33 is arranged behind the rear face of suspension frame 1 and this gear wheel 33 just engages the end of rack 14.

Disposed under the rack is a guide section 31, which, near the rear end of cabinet section 13, has a downwardly curved portion 36. This guide section 31, 36 may also consist of a guide slot arranged in a side wall 30 projecting downwardly under the rack 14. The gear wheel 33 is provided with a laterally projecting stub 35, pointing forwards from the plane of the drawing, which is received in the guide section 31. When pushing in the suspension frame 1, the gear wheel 33 rolls over the rack 14. On the opposite side of the suspension frame 1 there is of course a corresponding gearbox 32 with the gear wheels 28, 33, 34, the gear wheel 33 likewise engaging a rack 14 and a guide section 31 disposed on that side.

After the suspension frame 1 has been pushed in over some distance, the gear wheel 28 likewise engages the rack 14, so that the two gear wheels 33, 28 roll over the rack 14 along a substantial part of the translation movement of suspension frame 1. At the end of the closing movement the gear wheel 33 is forced by the projecting stub 35 to follow the curved portion 36 of guide section 31, 36, so that the gear wheel 33 leaves the position in which it engages the rack 14. The anti-racking effect is now exclusively adopted by the gear wheel 28, the stud 27 and the corresponding gear wheel 28 disposed at the other end thereof. The gearbox 32 makes a tilting movement about the stud 27, until, as shown in Fig. 8, the gearbox 32 has tilted through 90° and the gear wheel 28 has arrived at the end of the rack. The suspension frame 1 is now in the completely housed position, with the rear end of suspension frame 1 practically abutting against the rear wall of the cabinet not shown.

When pulling out the suspension frame 1, the gear wheels 28 roll over the respective racks 14, until the gearbox has been tilted through about 90° and the gear wheel 33 engages the rack 14. In order to cause the gear wheel 33 to properly engage the rack, there is provided an intermediate or synchronizing gear wheel 34, which ensures that the teeth of gear wheel 33 do not rub on the teeth of rack 14.

### Claims

1. A slidable drawer, provided on both sides with a telescopic guide consisting of a drawer section, a central section and a cabinet section, each cabinet section being provided with a rack engaging a gear wheel connected to the drawer and mounted on a shaft, characterized in that each rack (14) is provided on the pulling side of the cabinet section (13) with a tiltable extension piece (16) connected to said rack (14) and having teeth (19), which extension piece can be brought into the lowered position when pulling out the drawer (1) and into the raised position when pushing in the drawer (1).
2. A drawer as claimed in claim 1, characterized in that the extension piece (16) is provided with a curved end (18), which, in the lowered position of said extension piece (16), is in the path of movement of a laterally projecting part (21) of the drawer (1).
3. A drawer as claimed in claims 1-2, characterized in that the extension piece (16) is provided at the side facing the rack (14) with a stop face (17) for aligning said extension piece (16) in the lowered position.
4. A drawer as claimed in claims 1-3, characterized in that the two gear wheels (8) connected to the drawer (1) are disposed on a through-going shaft (7) and are arranged in front of the rear end (3) of the drawer (1), seen in the opening direction (R).
5. A drawer as claimed in claim 1, characterized in that the gear wheel (28) engaging the rack (14) is included in a gearbox (32) with three intermeshing gear wheels (28, 33, 34), two (28, 33) of which can mesh with said rack (14), which gearbox (32) is tiltably mounted in regard to the drawer (1).
6. A drawer as claimed in claim 5, characterized in that a guide section (31, 30) is present under each rack (14), which guide section guidably receives a stub (35) projecting beyond the gear wheel (33) rearmost in the opening direction (R) of the drawer (1), said guide section (31, 36) having a downwardly curved portion (36) near the end of the cabinet section (13) that is rearmost in the opening direction (R).
7. A drawer as claimed in claims 5-6, characterized in that the curved portion (36) of the guide section (31, 36) is such that in the completely closed position of the drawer (1) the gearbox (32) is tilted through about 90°, while in that position the gear wheel (28) foremost in the opening direction (R) engages the rack (14).
8. A drawer as claimed in claims 5-7, characterized in that in the completely opened position of the drawer (1) the gear wheel (33) rearmost in the opening direction (R) just engages the end of the rack (14).
9. A drawer as claimed in claims 5-8, characterized in that the gear wheel (28) foremost in the opening direction (R) is arranged in front of the rear face (3) of the drawer (1), seen in the opening direction (R).
10. A drawer as claimed in claims 5-9, characterized in that the rack (14) and the guide section (31, 36) are combined to one part, said guide section (31, 36) consisting of a guide slot arranged in a side wall (30) projecting under the rack (14).

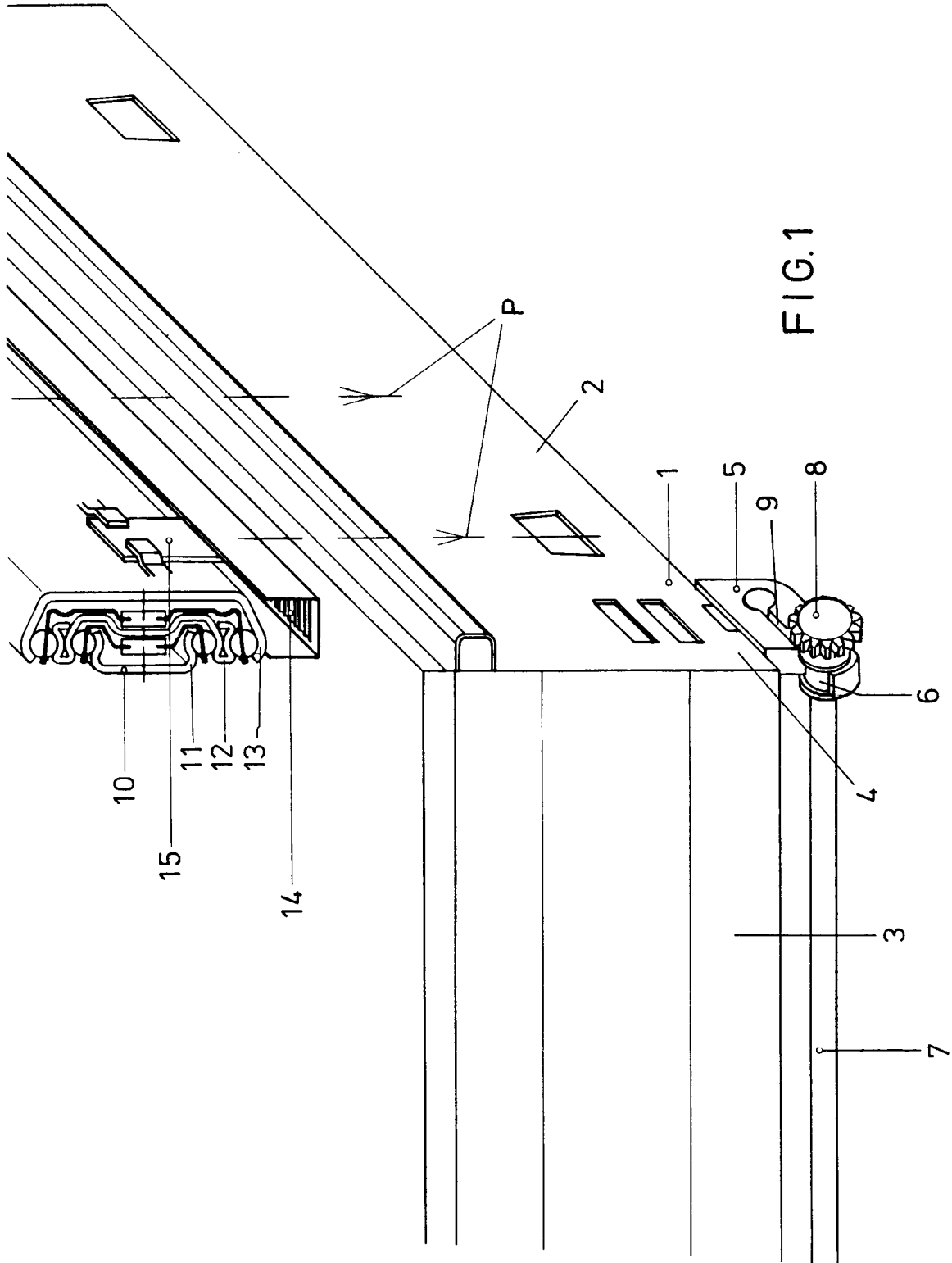

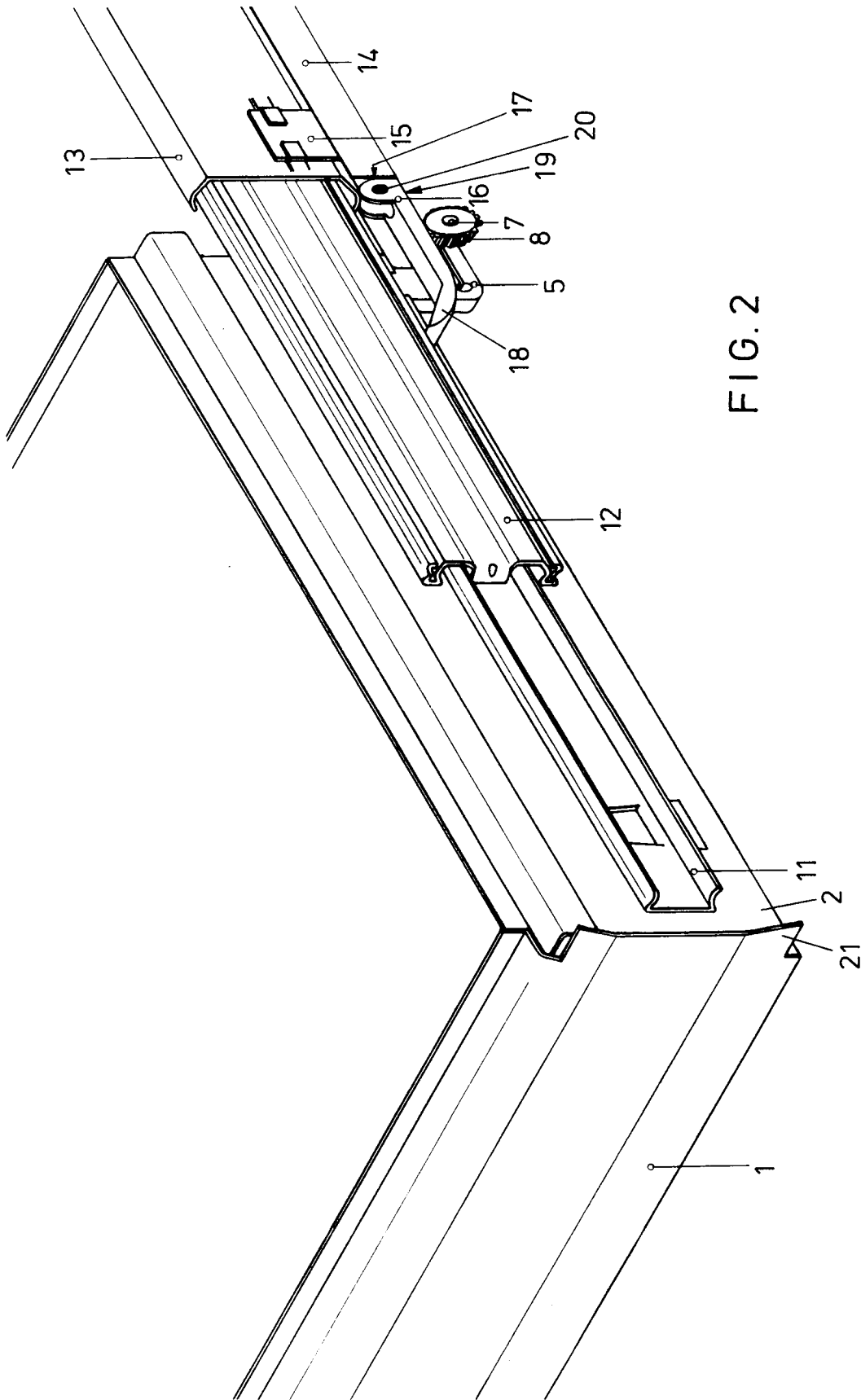

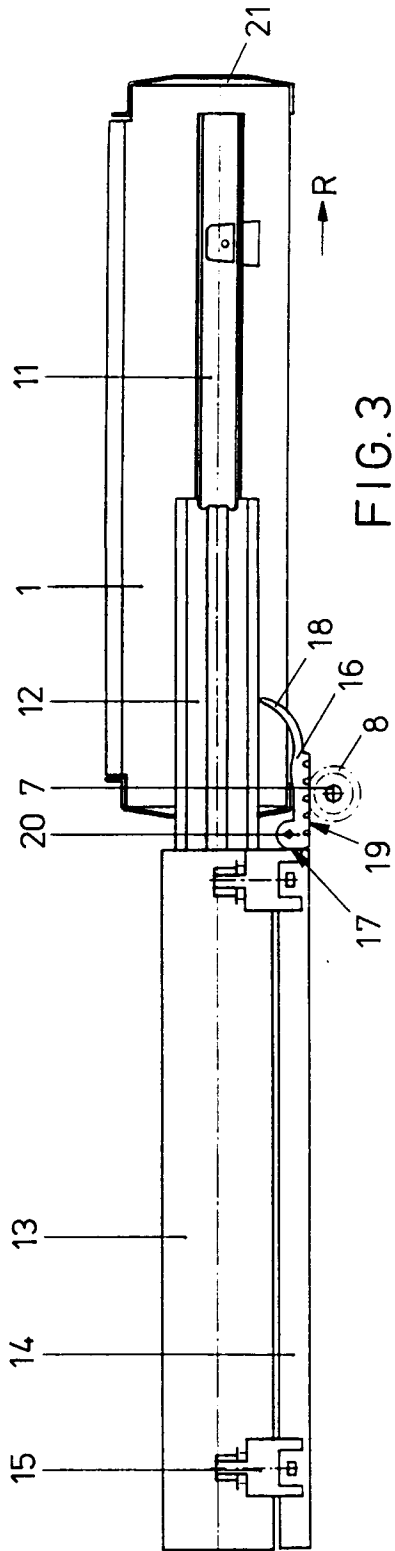

FIG. 3

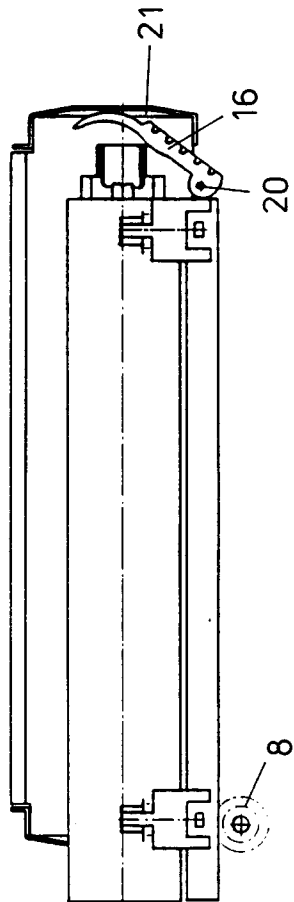

FIG. 4

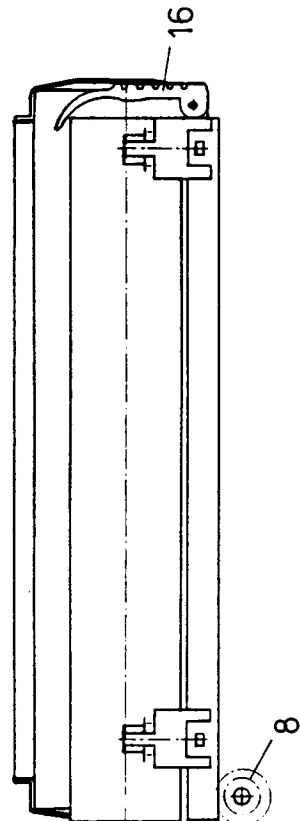
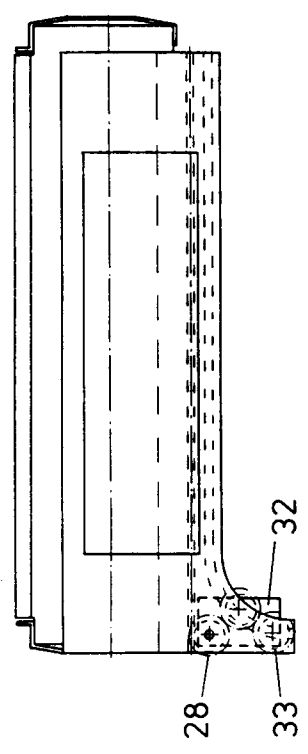
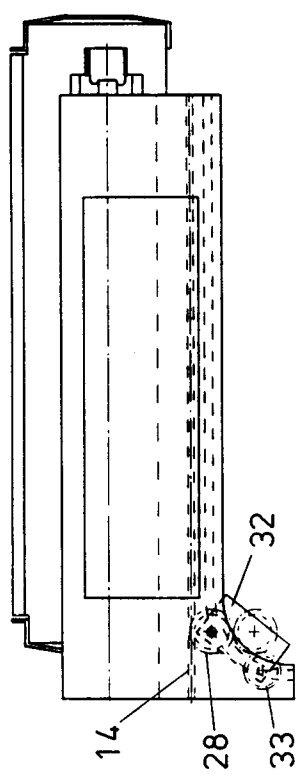
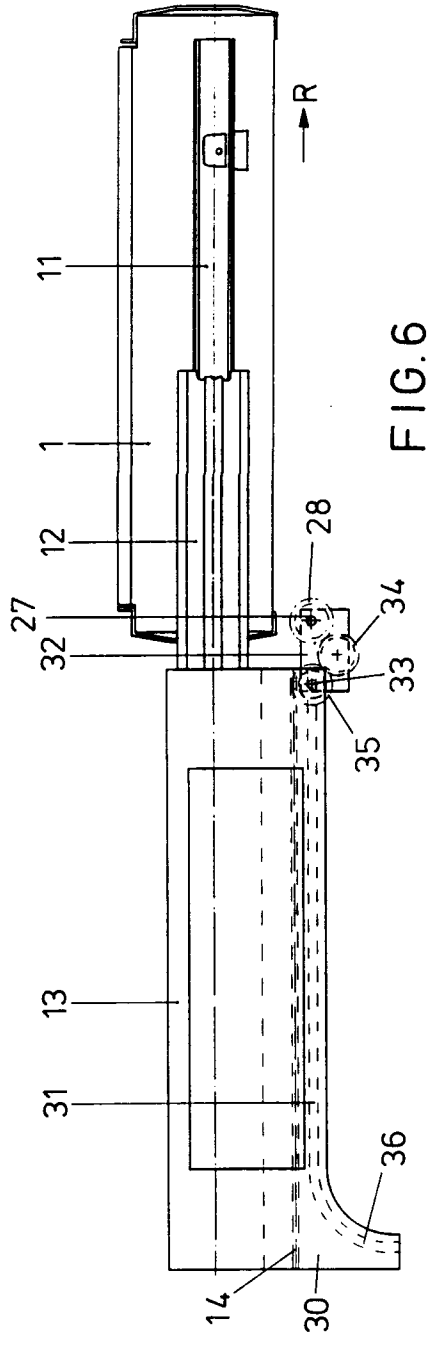

FIG. 5





DOCUMENTS CONSIDERED TO BE RELEVANT			
Category	Citation of document with indication, where appropriate, of relevant passages	Relevant to claim	CLASSIFICATION OF THE APPLICATION (Int. Cl.5)
A	US-A-2 174 181 (RANO) * claim 1; figures 1,2,11 * ---	1,5,6,8,9	A47B88/04 A47B88/10
A	FR-A-2 605 202 (FOLLIET) * abstract; figures 1,2 * ---	1	
A	CH-A-240 433 (UNION KASSENFABRIK A.G.) * claims 1,2; figures 1-3 * ---	7	
A	US-A-4 324 439 (HAGEN, RASK) * abstract; figures 1,3,4 * -----	1,4	
			TECHNICAL FIELDS SEARCHED (Int. Cl.5)
			A47B
The present search report has been drawn up for all claims			
Place of search	Date of completion of the search	Examiner	
THE HAGUE	04 AUGUST 1992	JONES C. T.	
CATEGORY OF CITED DOCUMENTS		T : theory or principle underlying the invention	
X : particularly relevant if taken alone		E : earlier patent document, but published on, or after the filing date	
Y : particularly relevant if combined with another document of the same category		D : document cited in the application	
A : technological background		L : document cited for other reasons	
O : non-written disclosure		.....	
P : intermediate document		& : member of the same patent family, corresponding document	