



EUROPEAN PATENT APPLICATION

Application number : **92304268.3**

Int. Cl.⁵ : **H01F 27/28**

Date of filing : **12.05.92**

Priority : **15.05.91 US 700734**

Inventor : **Gordon, James Carlton**
West Hurley
New York 12449 (US)
 Inventor : **Meyer, Herman Paul**
Rifton
New York 12471 (US)

Date of publication of application :
19.11.92 Bulletin 92/47

Designated Contracting States :
DE FR GB

Representative : **Moss, Robert Douglas**
IBM United Kingdom Limited Intellectual
Property Department Hursley Park
Winchester Hampshire SO21 2JN (GB)

Applicant : **International Business Machines Corporation**
Old Orchard Road
Armonk, N.Y. 10504 (US)

An improved transformer.

A planar transformer (300) includes an "E" core (106) having first (128) and second (130) windows and a central core leg (110). First (320) and second (322) conductive plates are threaded through the first and second windows to encircle the central core leg. The first and second conductive plates are disposed substantially in parallel and define first and second electrical paths, respectively, around the central core leg. First (324) and second (326) transverse conductor portions connect the first and second conductive plates such that a first end of the first electrical path is connected to a first end of the second electrical path, and a second end of the first electrical path is connected to a second end of the second electrical path, whereby a parallel electrical connection is established between the first and second conductive plates. A third conductor (314) is threaded through the first and second windows to encircle the central core leg. The third conductor is disposed between the first and second conductive plates.

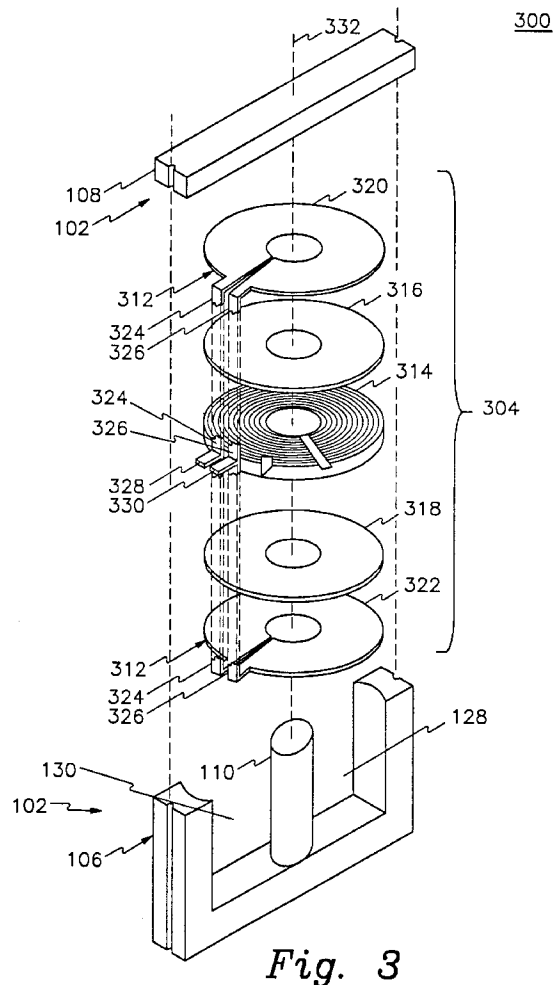

Field of the Invention

This invention relates generally to the art of high current transformers. More specifically, the invention is a planar transformer having a forked secondary which allows increased power density.

5

Background of the Invention

Switching power supplies for large data processing systems are required to supply large loads, often in the multiple kilowatt range. This is commonly low voltage (e.g., 5V) at high current values (e.g., 600A). Conventional design of these transformers leads to large, bulky structures having major size and weight impacts, large leakage inductances, high temperature rises and associated cooling problems.

10

Higher switching frequencies have been accepted as one means for reducing transformer size and increasing power density. With higher frequencies, however, comes the further complications of skin and proximity effects. At frequencies in the kiloHertz range and currents in the hundreds of amperes, skin and proximity effects play a predominant role in determining the effective AC resistance of current carrying conductors.

15

Skin and proximity effects are both eddy current effects which cause the current flowing in a conductor to use only a small portion of the available conductor cross-section. This causes increased AC resistances and, accordingly, greater power losses with associated high temperature rises in the transformer.

The conventional method for handling increased power dissipation and increased heating was to increase the magnetic core size and use larger conductor wire. Increasing transformer size, however, contradicts the primary reason for using the higher switching frequencies (i.e., to reduce size). Further, large geometries bring with them increased stray inductances. At high frequencies, increased inductances tend to limit the amount of current which can be switched through the transformer.

20

In planar type transformers, designers have increased power densities by improving the thermal conductivity of the thermal paths of a transformer. U.S. Pat. No. 4,754,390 to Felton *et al.* is exemplary of a transformer directed to improving heat conduction/transfer while reducing leakage inductances.

25

An ideal solution for increasing power densities would be to reduce skin and proximity effects so that available conduction area could be utilised more efficiently. This would allow increased power densities and/or reduced size magnetic devices.

30

Disclosure of the Invention

The present invention is a planar transformer which reduces skin effects and proximity effects and thereby achieves reduced conduction power losses. This is accomplished by using a novel secondary shaped in a fork configuration.

35

The invention provides a transformer comprising a core forming a closed magnetic circuit; a secondary comprising a plurality of conductive plates threaded through the magnetic circuit and defining a respective plurality of electrical paths; and a primary comprising one or more conductors threaded through the magnetic circuit, each of the conductors being disposed between adjacent ones of the conductive plates.

40

The core is preferably an 'E' core including two windows forming closed magnetic circuits and the conductive plates and conductors are threaded through the windows. The conductive plates are preferably substantially annular in shape.

The secondary preferably further comprises a plurality of conductors arranged to connect the plurality of electrical paths in parallel or in series. The primary preferably is a coil of thin flat ribbon shaped wire wound edgewise.

45

An embodiment of the invention has a secondary consisting of two conductive plates threaded through the magnetic circuit and a primary consisting of a single conductor threaded through the magnetic circuit. A further embodiment of the invention has a secondary consisting of three conductive plates threaded through the magnetic circuit and a primary consisting of two conductors threaded through the magnetic circuit.

50

Brief Description of Drawings

The invention will now be described, by way of example only, with reference to the accompanying drawings, like components being referenced by the same reference numerals, in which:

55

FIG. 1 shows an exploded perspective view of a known planar transformer;

FIG. 2 is a partial cross-section showing the operational relationship between primary winding 116 and secondary plate 112 of the known planar transformer;

FIG. 3 shows an exploded perspective view of a first embodiment of a planar transformer of the present

invention;

FIG. 4 is a cross-sectional view of winding piece 304 used in the planar transformer of FIG. 3;

FIG. 5 is a top view of secondary 312 used in the winding piece of FIG. 4;

FIG. 6 is a partial cross-section showing the operational relationship between primary winding 314 and secondary 312 of the transformer of FIG. 3;

FIG. 7 is an exploded cross section of a second embodiment of a planar transformer 702 of the present invention;

FIG. 8 is a cross-sectional view of secondary 704 used in the transformer of FIG. 7; and

FIG. 9 is a cross-section showing the operational relationship between primary windings 706 and 708 and secondary 704 of the transformer of FIG. 7.

Detailed Description of the Invention

As discussed above, proximity and skin effects are both eddy current effects which cause the current flowing in a conductor to use only a small portion of the available conductor cross-section. A brief explanation of skin effects and proximity effects is presented below.

Skin effects are caused by current crowding in a conductor due to its own magnetic field. The current density is caused to be greatest near the surface of the conductor and to decrease exponentially towards the centre of the conductor. Skin effects can be calculated as follows.

The conduction current density at any point within a conductor is given by the following equation:

$$J = \sigma E e^{-z(\pi f \mu \sigma)^{1/2}} - \cos[\omega t - z(\pi f \mu \sigma)^{1/2}]$$

where: J = current density

E = electric field intensity

z = perpendicular distance from
conductor surface (z > 0 into the
conductor)

f = AC frequency (Hz)

μ = permeability constant

$$= 1.26 \times 10^{-6} \text{ (H/m)}$$

σ = conductivity (S/m)

It can be seen from this equation that an exponential decrease in the conduction current density and electric field intensity occurs with penetration into the conductor. At a distance

$$z = \frac{1}{(\pi f \mu \sigma)^{1/2}}$$

the exponential term (e⁻¹) = 0.368, yielding a current density

$$J = (0.368) \sigma E$$

This is a special value of z known as the "skin depth" (δ). The skin depth is represented by the equation:

$$\delta = \frac{1}{(\pi f \mu \sigma)^{1/2}}$$

At one skin depth (z = δ), 63% or (1-0.368) of the current will be concentrated in a cross-section of the conductor to a depth of δ.

For copper (σ = 5.8 X 10⁷ S/m), this equation reduces to:

$$\delta = \frac{0.0066}{(f)^{1/2}}$$

From this equation, it can be shown that at an operating frequency of 100kHz, for example, skin depths are in the order of 0.21 mm (0.008") in a copper conductor.

Proximity effects are caused by exposure of the current carrying conductor to an external magnetic field. The external magnetic field causes the current density in a conductor to be much higher in some areas than in others, much like a conductor's own magnetic field does to cause skin effects. Thus, proximity effects exacerbate the existing problem caused by skin effects.

For a transformer, proximity effects are a function of many different variables including the number of turns per winding, winding technique, and overall transformer geometry. As a result, proximity effects are not susceptible to precise mathematical characterisation. Proximity effects are, however, well known in the art, and data is available by which the combination of skin and proximity effects on the AC resistances of a conductor can be predicted.

For purposes of this discussion, it will suffice to assume that proximity effects will enhance the skin effects to cause a current to concentrate in the portion of a conductor near the primary/secondary interface of a transformer.

A known planar transformer 100 is shown in exploded form in FIGURE 1. Transformer 100 includes core 102 and winding piece 104. Core 102 is an "E" core comprising an "E" piece 106 and a cap piece 108. When "E" piece 106 and cap piece 108 are brought into contact as shown by the dash lines 132 and 134, core 102 forms windows 128 and 130. "E" piece 106 has a centre post 110 which divides windows 128 and 130. The core can alternatively be a 'U' core comprising a 'U' piece and a cap piece.

Winding piece 104 includes a secondary plate 112, an insulating plate 114, and a primary coil 116. Primary coil 116 is wound from "ribbon" or "tape" conductors which are relatively wide, thin, flat, conductors wound edge-wise. This primary coil configuration is known in the art to decrease leakage inductance and eddy current losses.

Primary coil 116 has a first end 118 and a second end 120 adapted for making electrical connection thereto. Insulating plate 114 maintains electrical isolation and permits thermal conduction between primary coil 116 and secondary plate 112.

A pair of terminals 122 and 124 allow electrical connections to be made to secondary plate 112. Secondary plate 112, insulating plate 114 and primary coil 116 have central openings 136, 138 and 140, respectively, passing therethrough. Central openings 136, 138 and 140 are aligned concentrically about a central axis 126 to form a central window through winding piece 104. This central window is adapted to accept centre post 110 of core 102. Thereby, both primary winding 116 and secondary plate 112 pass through core windows 128 and 130. In this manner, core 102 provides magnetic coupling between primary winding 116 and secondary plate 112.

FIGURE 2 shows a cross section of primary coil 116 and secondary plate 112 of known transformer 100. Elements 202 illustrate the individual cross sections of the conductor ribbon which form primary coil 116. Cross-hatched areas 204, and cross-hatched areas 206 on secondary plate 112, depict the portions of the conductors (to one skin depth) which would be carrying substantially all (63%) of the primary current.

For a conductor ribbon having a thickness of 0.46 mm (0.018") and a height of 9.5 mm (0.375") conducting current at 100 kHz, the total cross-sectional area depicted would be $9.66 \times 10^{-8} \text{ m}^2$ ($1.44 \times 10^{-4} \text{ inches}^2$) out of a possible $4.38 \times 10^{-6} \text{ m}^2$ ($6.75 \times 10^{-3} \text{ inches}^2$). Thus, 63% of the total current would be concentrated in 2% of the available conductor. This results in a high AC resistance which causes high power losses and corresponding high temperature rises.

Two preferred embodiments of the present invention are now described with reference to FIGURES 3 - 9. FIGURE 3 shows a first embodiment. A planar transformer 300 includes an "E" core 102 as described above, and a winding piece 304. Winding piece 304 is coupled to core 102 as described above.

Winding piece 304 comprises secondary 312, primary coil 314, and insulator plates 316 and 318. Secondary 312 includes a first secondary plate 320 and a second secondary plate 322. Plates 320 and 322 are arranged in a forked configuration with a first transverse portion 324 and a second transverse portion 326 making the connection therebetween. Transverse portions 324 and 326 are shown broken to correspond to the exploded view of the drawing. Terminals 328 and 330, formed in transverse portions 324 and 326 respectively, allow electrical connection to secondary 312. The electrical connection of the secondaries may be series connection or parallel connection. The embodiment of FIGURE 3 shows the connections arranged to connect the secondaries in parallel.

Primary coil 314 is disposed between plates 320 and 322 of secondary 312. Primary coil 314 is wound from "ribbon" or "tape" conductors. Insulating plates 316 and 318 are disposed at the primary/secondary interfaces formed between secondary plates 320 and 322 and primary winding 314. Insulating plates 316 and 318 are made from an electrically insulating, thermally conductive material. All elements of winding piece 304 are aligned concentrically about a central axis 332 to form a central window through winding piece 304.

A sectional side view of winding piece 304 is shown in FIGURE 4. FIGURE 5 shows a top view of the same. Only the secondary plate 312 and terminals 328 and 330 are visible in this view.

FIGURE 6 shows secondary 312 with primary coil 314 disposed between secondary plates 320 and 322. Elements 602 illustrate the individual cross sections of the conductor ribbon which forms primary coil 314. If primary 314 and secondary 312 were carrying current at 100 kHz as discussed above, then cross-hatched areas 604, and cross-hatched areas 606 of secondary 312, depict the portions of the conductors (to one skin depth) which would be carrying substantially all (63%) of the primary current. As can be seen, if compared with FIGURE 2, elements 602 are now conducting the current over twice the cross-sectional area of elements 202.

Thus, this novel configuration doubles the cross-sectional area through which the AC current flows.

Current is now being conducted at both sides of primary coil 314. Thus, a conductor ribbon (e.g., conducting current at 100 kHz) having dimensions as set forth above would conduct 63% of the total current over a cross-sectional area of $1.93 \times 10^{-7} \text{ m}^2$ ($2.88 \times 10^{-4} \text{ inches}^2$) out of a possible $4.38 \times 10^{-6} \text{ m}^2$ ($6.75 \times 10^{-3} \text{ inches}^2$). 63% of the total current would now be concentrated in 4% of the available conductor, resulting in a 100% increase in conduction area.

Doubling the cross-sectional area through which a current flows will cut the conduction area resistance by one-half. This will result in a corresponding 50% decrease in the conduction power losses in the primary coil and a corresponding decrease in the transformer temperature rise. Since the maximum output rating of any transformer is ultimately based on maximum allowable temperature rise, reduced losses allow a given design to be rated at a substantially higher output power. (Alternatively, the transformer of the present invention could be operated at a higher frequency, or the size of the transformer could be reduced.)

A second embodiment of the present invention is shown in an exploded cross-sectional view in FIGURE 7. Winding piece 702 includes a secondary 704, primary coils 706 and 708, and insulating plates 710, 712, 714, and 716. Secondary 704 includes a first secondary plate 718, a second secondary plate 720 and a third secondary plate 722. Plates 718, 720, and 722 are arranged in a forked configuration with transverse portions 723 and 724 making the connection therebetween. Terminals 728 and 730 extend outward from transverse portions 723 and 724, respectively, to permit electrical connection to secondary 704. Transverse portions 723 and 724 are shown broken to correspond to the exploded view shown in the drawing.

A first primary coil 706 is disposed between plates 718 and 720 of secondary 704. A second primary coil 708 is disposed between plates 720 and 722 of secondary 704. Primary coils 706 and 708 are wound from "ribbon" or "tape" conductors as described above. Insulating plates 710, 712, 714 and 716 are disposed at the primary/secondary interfaces formed between secondary plates 718, 720 and 722 and primary windings 706 and 708. Insulating plates 710, 712, 714, and 716 are made from an electrically insulating, thermally conductive material.

All elements of winding piece 702 are aligned concentrically about a central axis 726 to form a central window through winding piece 702. This central window is adapted to accept a core piece as described above.

A sectional side view of novel secondary 704 of winding piece 702 is shown in FIGURE 8. A top view of secondary 704 would be similar to that shown in FIGURE 5 for secondary 312.

FIGURE 9 shows secondary 704 with primary coils 706 and 708 disposed between secondary plates (718 and 720) and (720 and 722) respectively. Elements 902 illustrate the individual cross sections of the conductor ribbon which forms primary coils 706 and 708. Cross-hatched areas 904 for primary coils 706 and 708 and cross-hatched areas 906 for secondary 704, depict the portions of the conductors (to one skin depth) which would be carrying substantially all (63%) of a 100 kHz primary current. As can be seen if compared with FIGURE 2, elements 902 are conducting the current over twice the cross-sectional area of elements 202. Further, if primary coils 706 and 708 are connected in parallel, then the current is split between two primary coils (706 and 708) to further reduce the primary losses. The resulting primary resistance would be one fourth of that seen in primary coil 116.

Claims

1. A transformer comprising:
 - a core forming a closed magnetic circuit;
 - a secondary comprising a plurality of conductive plates threaded through said magnetic circuit and defining a respective plurality of electrical paths; and
 - a primary comprising one or more conductors threaded through said magnetic circuit, each of said conductors being disposed between adjacent ones of said conductive plates.
2. A transformer as claimed in claim 1, wherein
 - said core is an 'E' core including two windows forming closed magnetic circuits and said conductive plates and said conductors are threaded through said windows.
3. A transformer as claimed in any preceding claim, wherein said conductive plates are substantially annular in shape.
4. A transformer as claimed in any preceding claim, wherein said secondary further comprises a plurality of conductors arranged to connect said plurality of electrical paths in parallel.

5. A transformer as claimed in any one of claims 1 to 3, wherein said secondary further comprises a plurality of conductors arranged to connect said plurality of electrical paths in series.
- 5 6. A transformer as claimed in any preceding claim, wherein
said secondary consists of two conductive plates threaded through said magnetic circuit; and
said primary consists of a single conductor threaded through said magnetic circuit.
- 10 7. A transformer as claimed in claim 1 to claim 5, wherein
said secondary consists of three conductive plates threaded through said magnetic circuit; and
said primary consists of two conductors threaded through said magnetic circuit.
- 15 8. A transformer as claimed in any preceding claim wherein said primary is a coil of thin, flat ribbon shaped
wire wound edgewise.

15

20

25

30

35

40

45

50

55

100

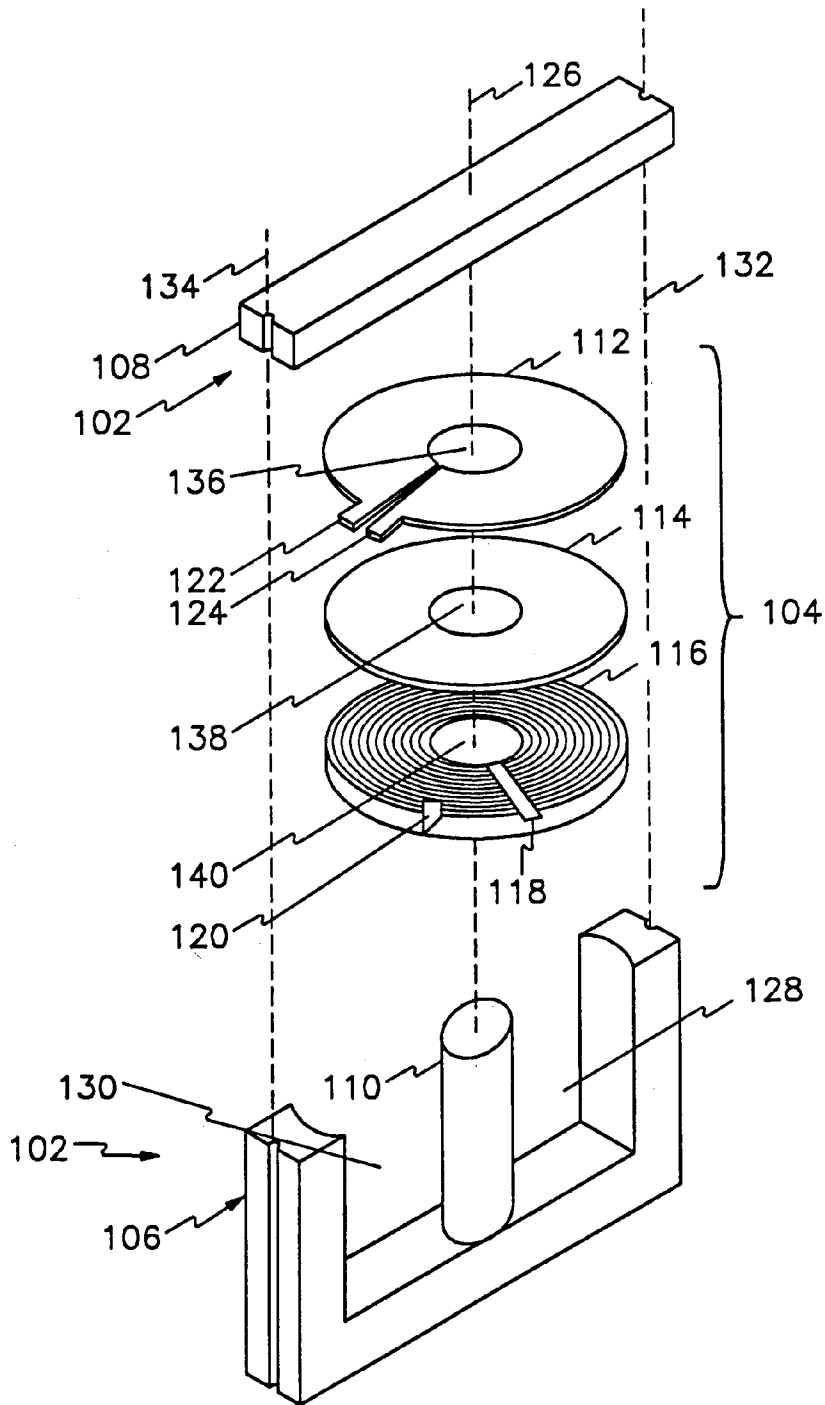

Fig. 1

PRIOR ART

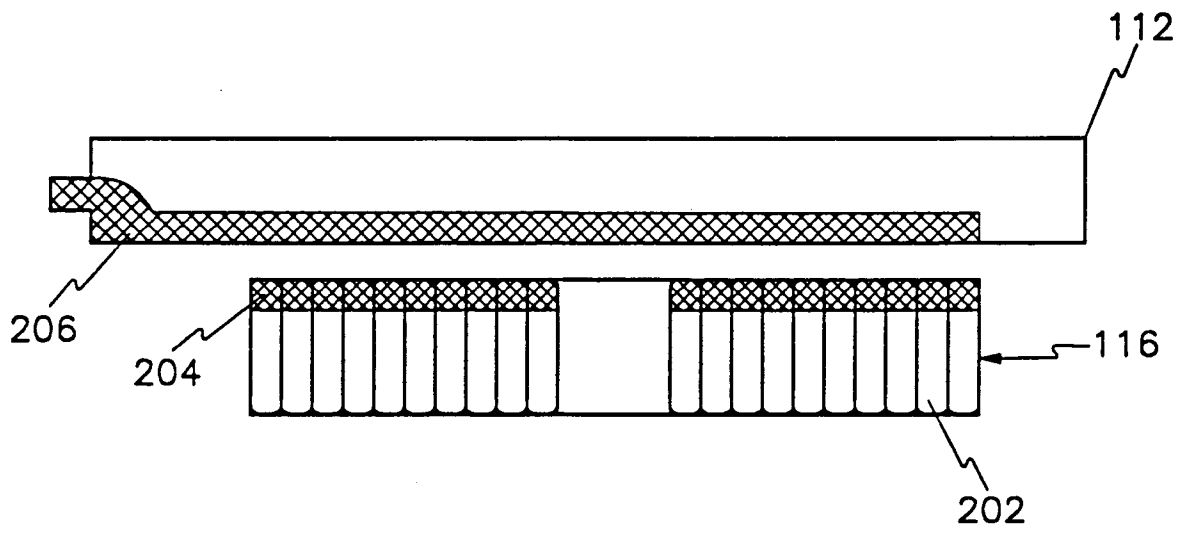

Fig. 2

PRIOR ART

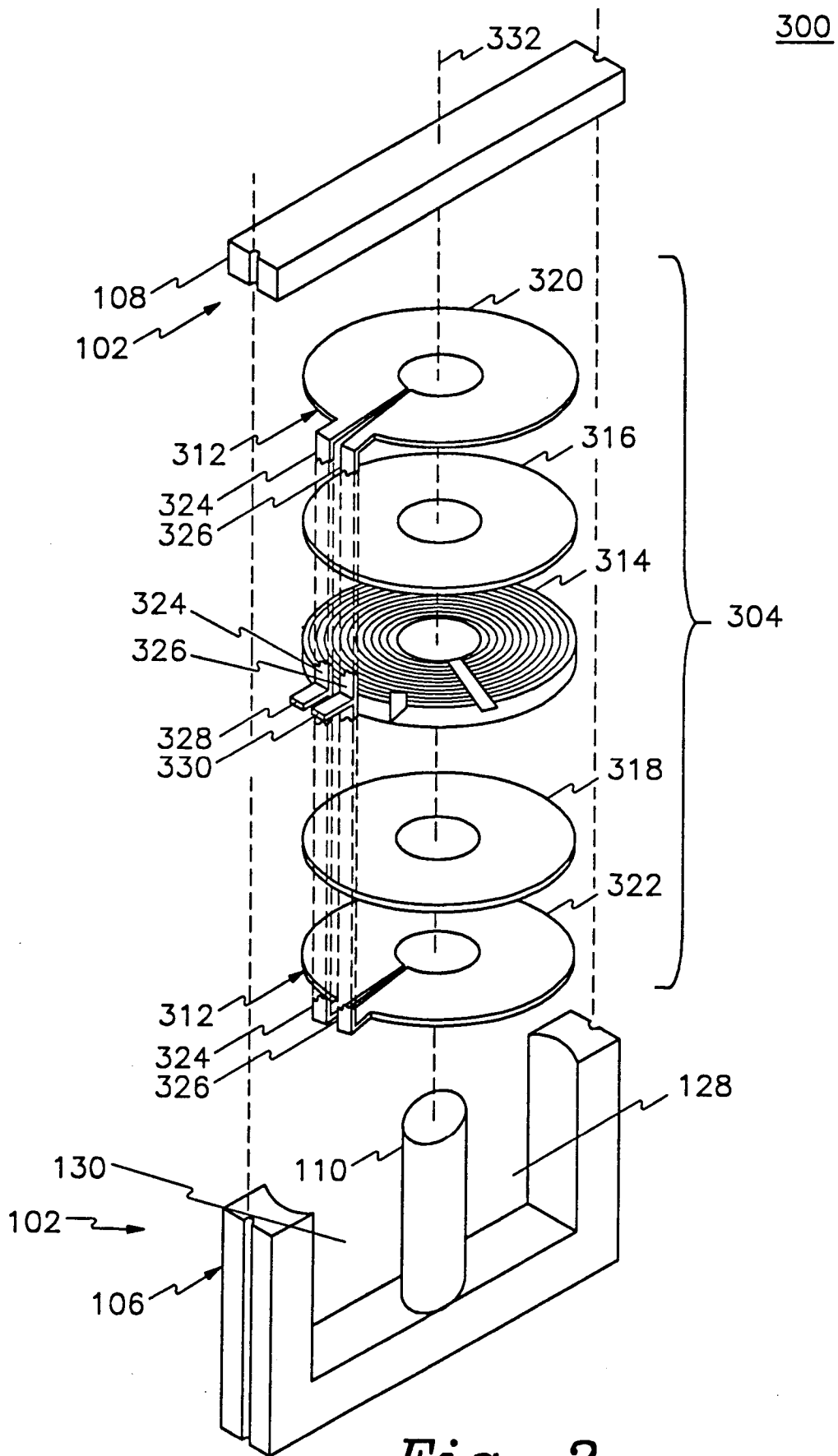

Fig. 3

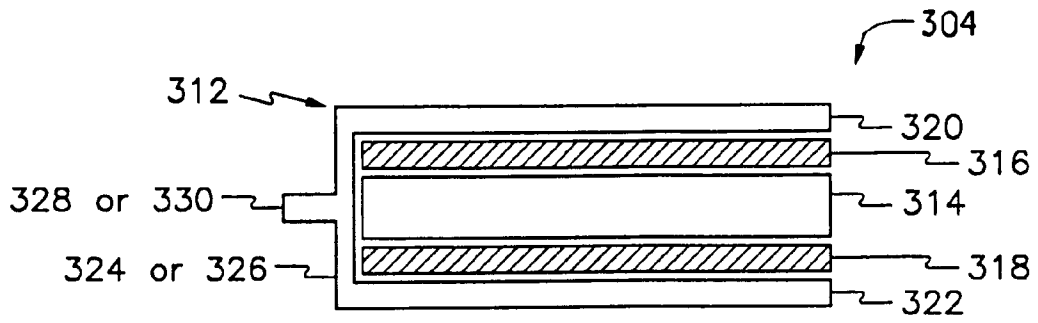

Fig. 4

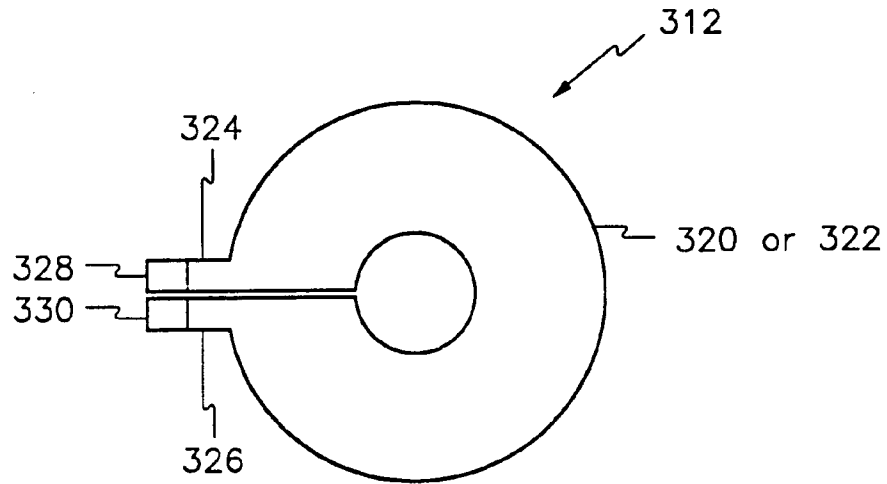

Fig. 5

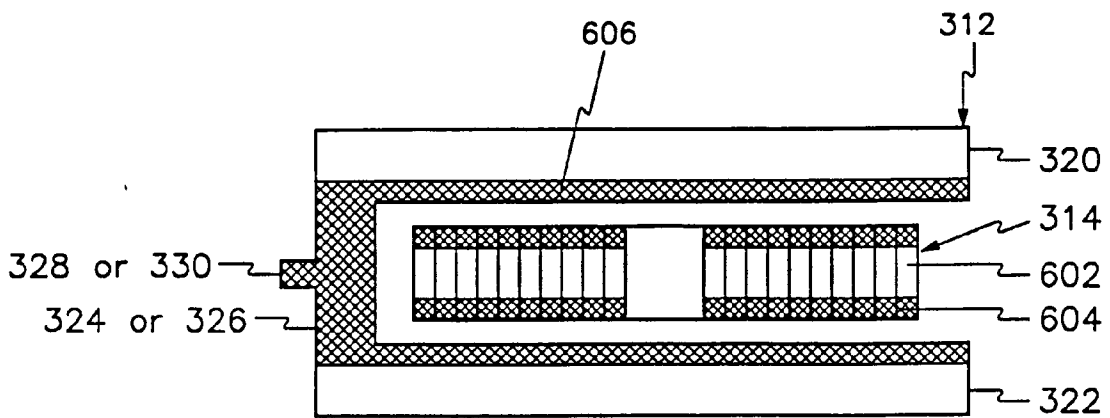

Fig. 6

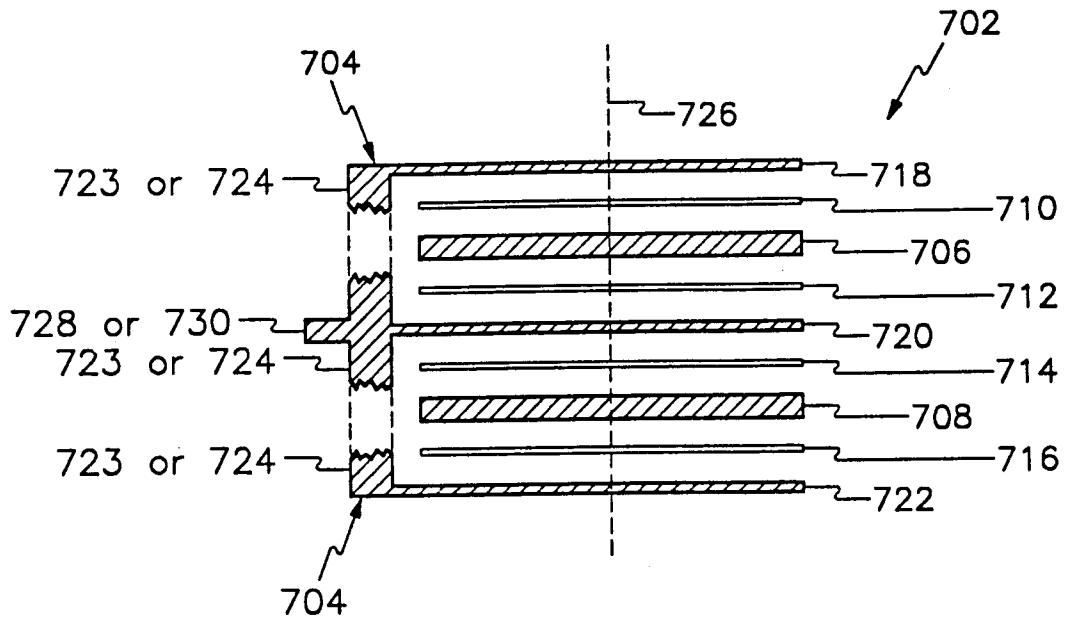

Fig. 7

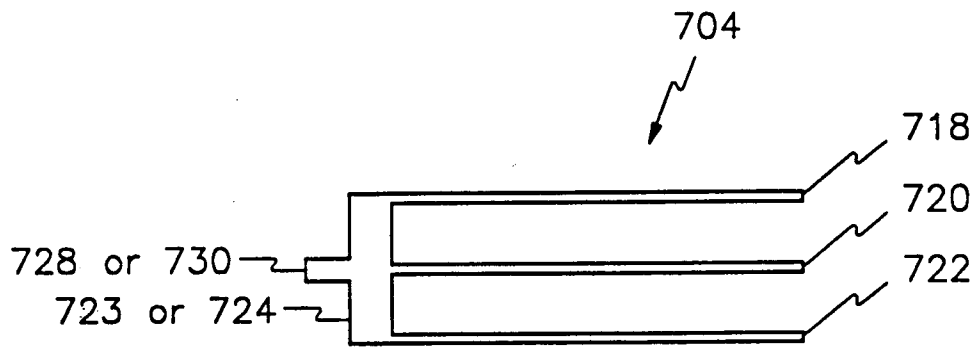

Fig. 8

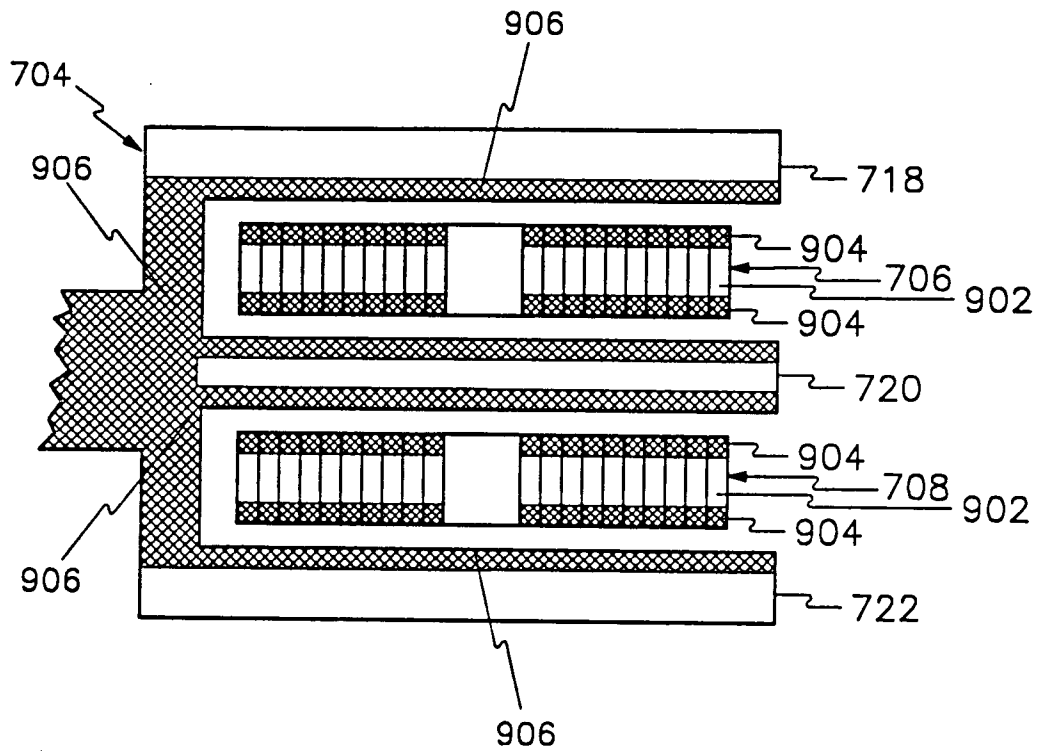

Fig. 9



European Patent
Office

EUROPEAN SEARCH REPORT

Application Number

EP 92 30 4268

DOCUMENTS CONSIDERED TO BE RELEVANT			
Category	Citation of document with indication, where appropriate, of relevant passages	Relevant to claim	CLASSIFICATION OF THE APPLICATION (Int. Cl.5)
X	EP-A-0 293 617 (VACUUMSCHMELZE) * column 3, line 15 - column 4, line 51; figures 1,2 *	1-3	H01F27/28
A	---	7	
A	EP-A-0 165 845 (BULL SEMS) * page 3, line 25 - page 5, line 9 * * page 9, line 7 - line 15; figures 1,2,9A-9D *	1,2,4-6	
A	PATENT ABSTRACTS OF JAPAN vol. 9, no. 150 (E-324)(1873) 25 June 1985 & JP-A-60 030 110 (FUJI DENKI SEIZO) * abstract *	8	
A	PATENT ABSTRACTS OF JAPAN vol. 10, no. 217 (E-423)(2273) 29 July 1986 & JP-A-61 054 607 (MATSUSHITA ELECTRIC) * abstract *		
			TECHNICAL FIELDS SEARCHED (Int. Cl.5)
			H01F
The present search report has been drawn up for all claims			
Place of search THE HAGUE		Date of completion of the search 18 AUGUST 1992	Examiner MARTI ALMEDA R.
CATEGORY OF CITED DOCUMENTS X : particularly relevant if taken alone Y : particularly relevant if combined with another document of the same category A : technological background O : non-written disclosure P : intermediate document		T : theory or principle underlying the invention E : earlier patent document, but published on, or after the filing date D : document cited in the application L : document cited for other reasons & : member of the same patent family, corresponding document	

EPO FORM 1503 01.82 (P0401)