



EUROPEAN PATENT APPLICATION

Application number : **92304620.5**

Int. Cl.⁵ : **B21D 5/08**

Date of filing : **21.05.92**

Priority : **24.05.91 GB 9111300**

Inventor : **Tranter, Brian**
19 Elm Grove, Norton
Bromsgrove (GB)

Date of publication of application :
25.11.92 Bulletin 92/48

Representative : **Brooke-Smith, Fred**
Stevens, Hewlett & Perkins 1 Serjeants' Inn
Fleet Street
London EC4Y 1LL (GB)

Designated Contracting States :
AT BE CH DE DK ES FR GB GR IT LI LU MC NL
PT SE

Applicant : **GUTTERFAST LIMITED**
Keepers Corner, Redehall Road, Smallfield
Horley, Surrey RH6 9RH (GB)

Formation of flat metal strip into channel section.

A machine for shaping flat metal strip (11) into a channel-section form (15) comprises a succession of aligned pairs of rollers through which the strip (11) can be fed to shape it into the channel-section form (15). The rollers are arranged also to form a curl (20) or flange (18) progressively along a lengthwise extending edge of the strip. Alternatively the curl (20) or flange (18) may be formed in an initial step, and in this case the rollers include means for accommodating the curl (20) or flange (18) for positively laterally locating the curl in its passage through the succession of rollers.

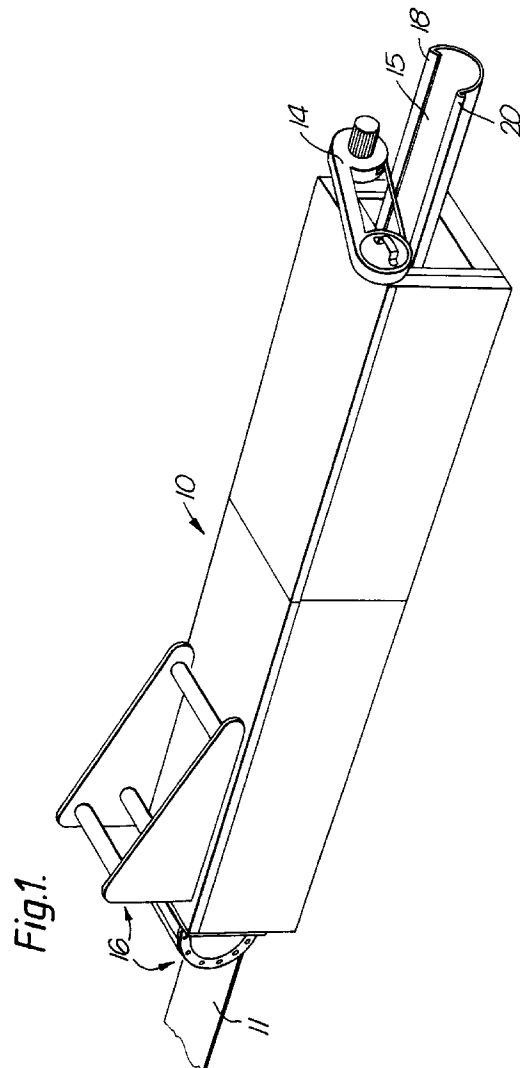

This invention relates to a method and apparatus for forming flat metal strip into channel section for use e.g. as guttering. There is a requirement for the formation of guttering in indeterminate long lengths, but machines currently available for this purpose are too heavy and too long, for example 9 metres long, to permit them to be used on site and transport problems thus limit the individual lengths of guttering which can be used.

In one aspect the present invention provides a method of shaping a length of sheet metal which is initially in flat strip form into a channel-section form by passing the strip through a succession of pairs of rollers which progressively shape the strip into a channel, characterized by the step of either initially forming a curl or flange along a lengthwise edge of the strip and positively locating the curl or flange as the strip passes through the pairs of rollers, or forming a curl or flange along a lengthwise edge of the strip progressively in said pairs of rollers simultaneously with the shaping of the strip into channel form.

In another aspect the invention provides apparatus for progressively shaping a length of sheet metal which is initially in flat strip form into a channel-section form comprising a succession of aligned pairs of rollers through which the strip is passed, said pairs of rollers being adapted progressively to shape the strip into a channel form, characterized in that said pairs of rollers are adapted to form a curl or flange along a lengthwise edge of the strip progressively and at the same time as the pairs of rollers shape the strip into said channel-section form.

The invention further provides apparatus for progressively shaping a length of sheet metal which is initially in flat strip form into a channel-section form comprising a succession of pairs of rollers through which the strip is passed, said pairs of rollers being adapted progressively to shape the strip into said channel-section form, characterized by means initially to form a flange or curl along a lengthwise edge of the strip and means associated with each pair of rollers to locate the curl laterally positively relative to such pair of rollers.

The apparatus may further comprise a saw disposed downstream of said pairs of rollers and arranged to be movable transversely of the channel-shaped strip to cut off a length of the strip.

The invention will now be described in more detail with reference to the accompanying drawings in which:

Figure 1 shows a general view of an apparatus according to the invention.

Figure 2 is a diagrammatic perspective view of a pair of rollers employed in forming a channel-shape, and

Figures 3 to 8 respectively illustrate the six stages in the formation of a channel from a flat metal strip by a method according to the invention.

Referring to Figures 1 and 2, there is illustrated an apparatus 10 according to the invention. A length of sheet metal in the form of a flat strip 11 is fed into the inlet of the apparatus and is formed into a channel section by a succession of pairs of rollers. As shown in Figure 2 each pair of rollers 12 comprises a convex upper roller and a complementary concave lower roller. Fixed push-up bars 13 are preferably provided at the approach side of at least the first pair of rollers 12 to engage the underside of the strip adjacent its opposite lengthwise edges to assist in the progressive deformation of the strip. At the discharge end of the apparatus a saw 14 is provided which is transversable to cut off a designed length of the completed channel-form strip 15. A set of decoiling rolls 16 is mounted on the apparatus adjacent the inlet end for supporting a roll of the flat metal strip 11 and guiding it into the inlet of the apparatus. For convenience of illustration the roll of strip has been omitted.

Referring now to Figures 3 to 8 of the drawings, six stages in the shaping of the channel are respectively illustrated. In the first set 12a of rollers shown in Figure 3, a curvature is imparted to the central part of the strip, and the formation of an inturned flange and an out-turned curl along opposite lengthwise edge portions 18, 20 of the strip is commenced. The edge portion 18 of the strip is turned upwardly at an angle to commence the formation of the flange and the opposite edge portion 20 is inclined downwardly and has its tip 21 turned more sharply downwardly.

In the second set 12b of the rollers illustrated in Figure 4, the curvature of the central region is increased, the edge portion 18 of the strip is turned substantially vertically upwardly, and the downward inclinations of the edge portion 20 and its tip 21 are increased.

In the third set 12c of the rollers illustrated in Figure 5, the curvature of the central region is again increased, the edge portion 18 is maintained directed upward and a convex curvature is imparted to the edge portion 20, its tip 21 being directed horizontally inwardly towards the central region.

In the fourth and fifth sets 12d and 12e of the rollers illustrated in Figures 6 and 7, the edge portion 18 is maintained in a vertical attitude and the convex curvature of the edge portion 20 is progressively increased, its tip 21 now being inclined upward.

In the sixth and final set 12f of the rollers illustrated in Figure 8 the curvature of the central region reaches its final form, the convex curvature of the edge portion 20 is formed into a curl, and the edge position 18 is turned inwardly and inclined downwardly.

We may form the curl separately in an initial operation, in which case each pair of rollers provides positive lateral location for the curl, but the method illustrated is greatly preferred because it permits channel-section metal strips of indeterminate length to be

produced direct from a roll of flat metal strip.

The invention has a particularly important application in relation to the manufacture of long lengths of guttering which is commonly made from zinc containing 0.5% titanium. The metal is widely used for this purpose because of its resistance to corrosion but the metal is difficult to draw. This problem has up to now been resolved by shaping the strip very gradually in machines which are commonly 9 or 10 metres in length. In the present method, however, the formation of the curl or flange provides a strong location datum at one edge of the strip, and the engagement of the curl or flange by the pairs of rollers thus permits each pair of rollers to impart a greater deformation to the central parts of the strip than has hitherto been found practicable, so that the apparatus is only a fraction of the length of currently available apparatuses. In one instance the present apparatus is only 3 metres in length and is relatively easily transportable in one piece.

5

10

15

20

of pairs of rollers through which the strip is passed, said pairs of rollers being adapted progressively to shape the strip into said channel-section form, characterized by means initially to form a flange or curl along a lengthwise edge of the strip and means associated with each pair of rollers to locate the curl laterally positively relative to such pair of rollers.

6. Apparatus as claimed in claim 4, further comprising rails arranged to engage under the marginal portions of the strip at the upstream side of at least one of the pairs of the rollers for assisting the forming action of the rollers.
7. Apparatus as claimed in claim 4, incorporating a saw for cutting off lengths of the channel-section form.

Claims

1. A method of shaping a length of sheet metal which is initially in flat strip form into a channel-section form by passing the strip through a succession of pairs of rollers which progressively shape the strip into a channel, characterized by the step of either initially forming a curl or flange along a lengthwise edge of the strip and positively locating the curl or flange as the strip passes through the pairs of rollers, or forming a curl or flange along a lengthwise edge of the strip progressively in said pairs of rollers simultaneously with the shaping of the strip into channel form.
2. A method as claimed in claim 1, wherein the strip is made from zinc containing 0.5% titanium.
3. A method as claimed in claim 1 or claim 2, comprising supplying the strip from a roll.
4. Apparatus for progressively shaping a length of sheet metal which is initially in flat strip form into a channel-section form comprising a succession of aligned pairs of rollers through which the strip is passed, said pairs of rollers being adapted progressively to shape the strip into a channel form, characterized in that said pairs of rollers are adapted to form a curl or flange along a lengthwise edge of the strip progressively and at the same time as the pairs of rollers shape the strip into said channel-section form.
5. Apparatus for progressively shaping a length of sheet metal which is initially in flat strip form into a channel-section form comprising a succession

25

30

35

40

45

50

55

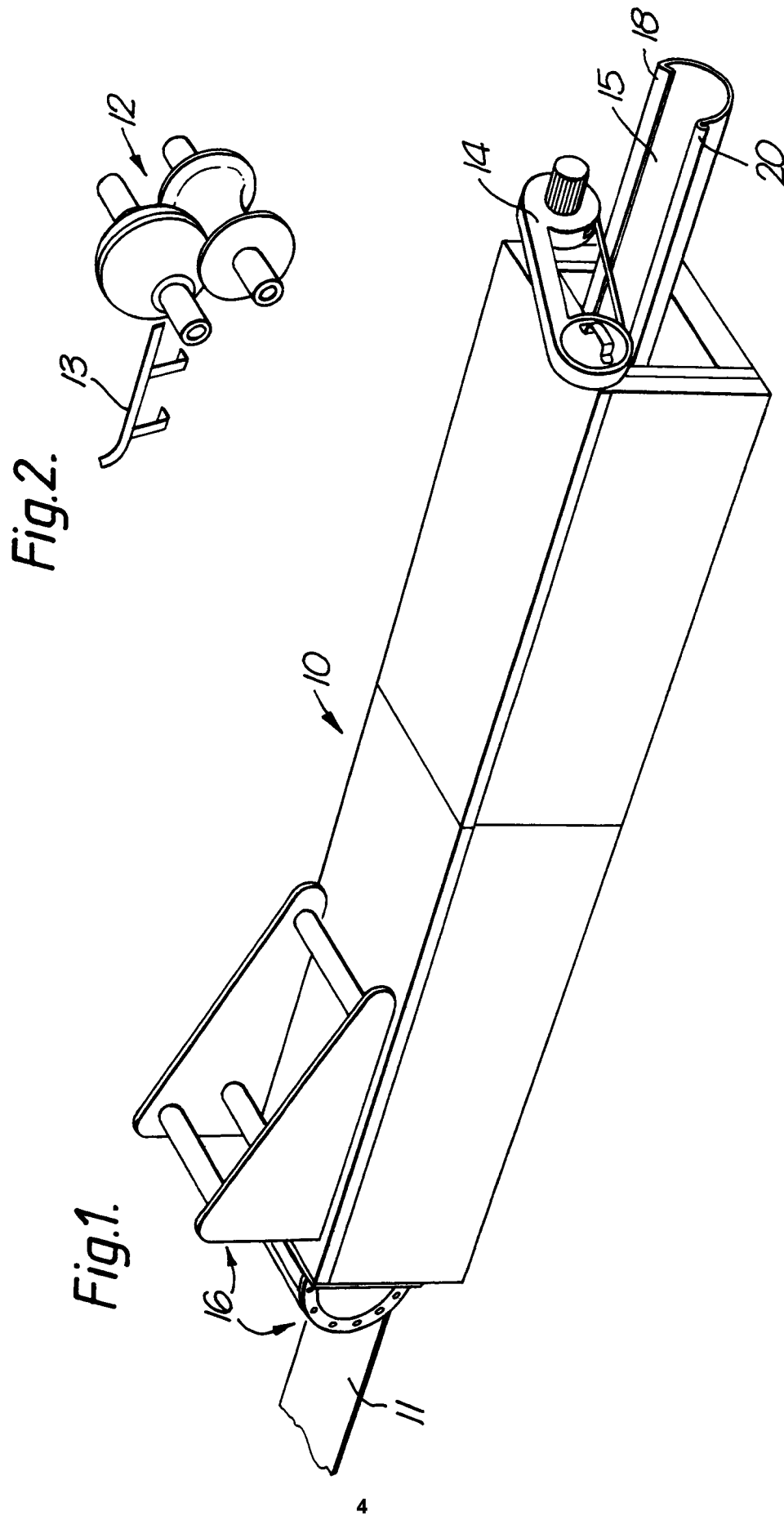

Fig.3.

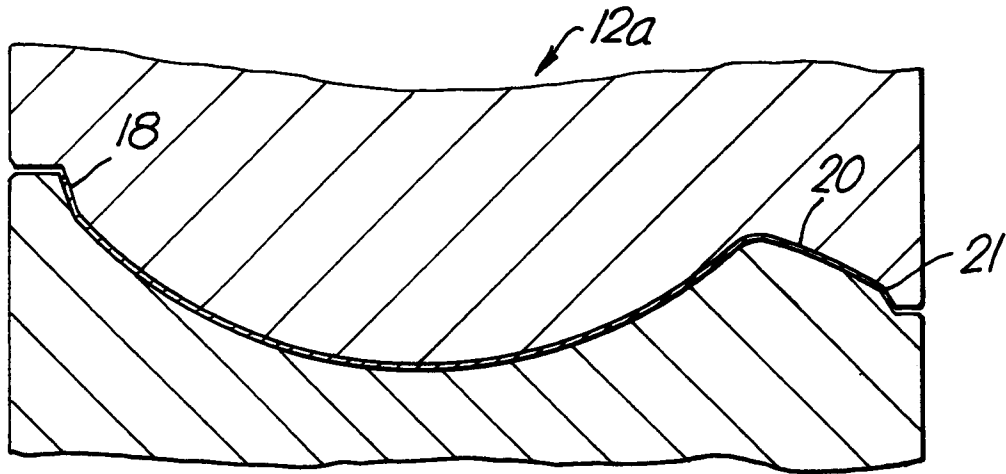

Fig.4.

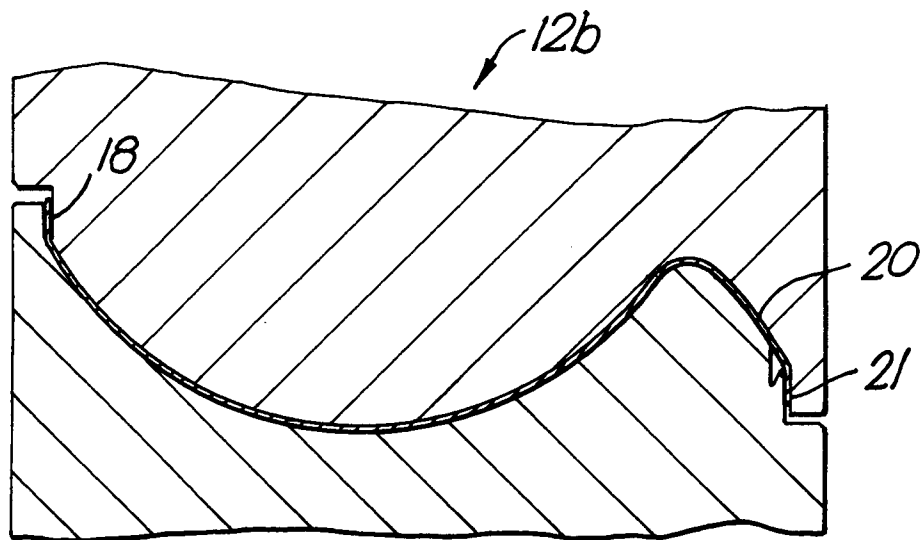

Fig.5.

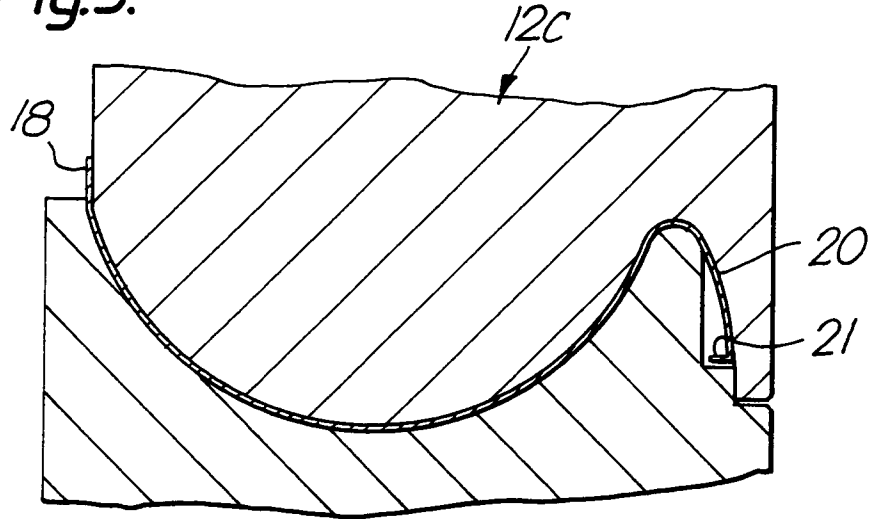

Fig.6.

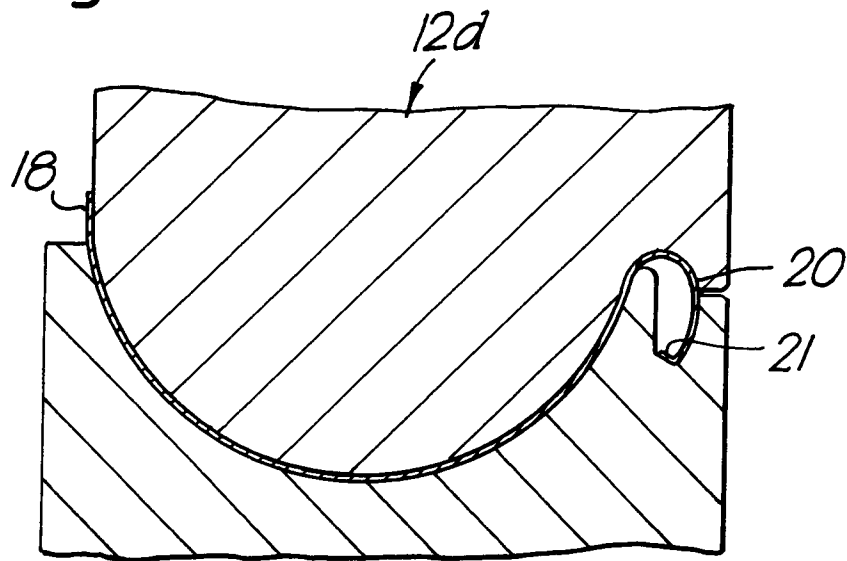

Fig.7.

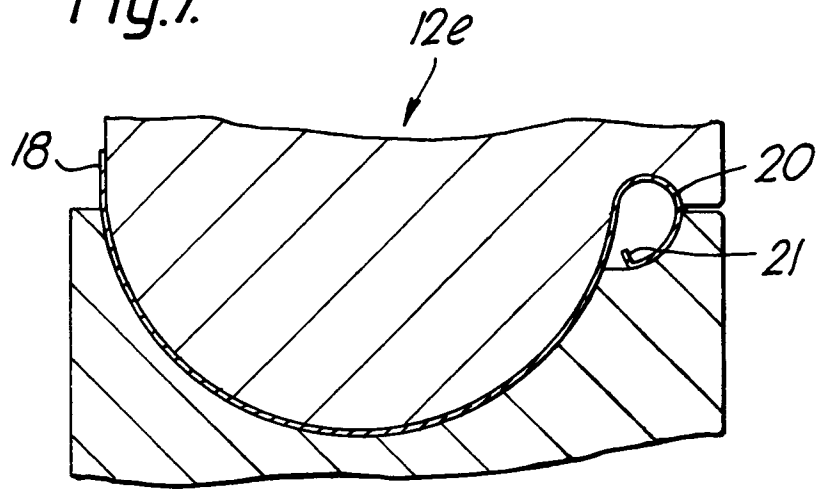
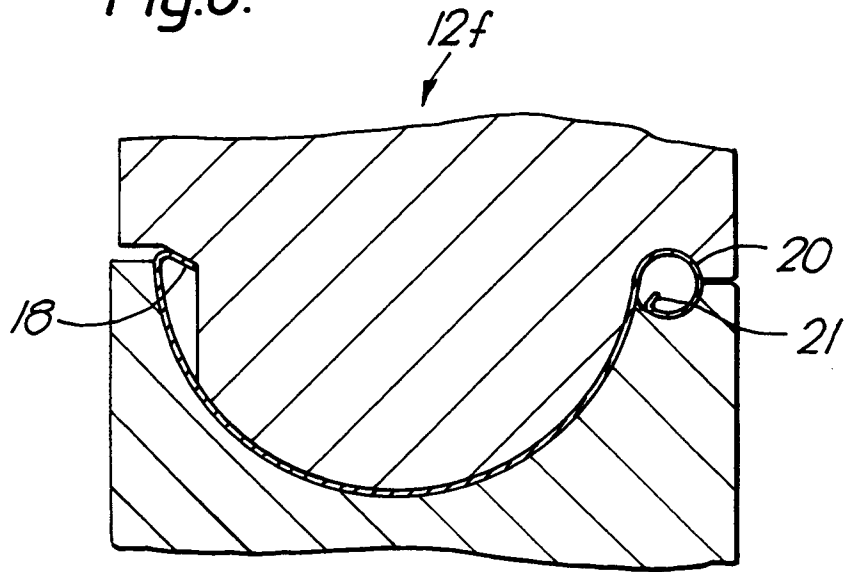

Fig.8.





European Patent
Office

EUROPEAN SEARCH REPORT

Application Number

EP 92 30 4620

DOCUMENTS CONSIDERED TO BE RELEVANT			
Category	Citation of document with indication, where appropriate, of relevant passages	Relevant to claim	CLASSIFICATION OF THE APPLICATION (Int. Cl.5)
X A	US-A-1 835 002 (H.P. BIRCKMAYER) * page 1, line 1 - line 11 * * page 2, line 56 - line 104; figures 1,11,12 * ---	1, 3, 4 7	B21D5/08
X	US-A-1 736 331 (A.J. TOMSEND) * page 2, line 55 - line 106; figures 6-11 * ---	1, 3, 4	
X	US-A-3 535 903 (T.W. ABERNATHY ET AL.) * figures 1-5 * ---	1, 4	
X	DE-C-163 330 (G.B. JOHNSON) * claims; figures 1-20 * ---	1, 3, 4	
X	US-A-1 377 252 (M.L. HUNKER) * claim 1; figures 5-26 * ---	1, 3, 5	
X	SU-A-940 911 (I.S. TRISHEVSKII) * figures * -----	1	
			TECHNICAL FIELDS SEARCHED (Int. Cl.5)
			B21D
The present search report has been drawn up for all claims			
Place of search THE HAGUE		Date of completion of the search 15 JULY 1992	Examiner THE K. H.
CATEGORY OF CITED DOCUMENTS X : particularly relevant if taken alone Y : particularly relevant if combined with another document of the same category A : technological background O : non-written disclosure P : intermediate document		T : theory or principle underlying the invention E : earlier patent document, but published on, or after the filing date D : document cited in the application L : document cited for other reasons & : member of the same patent family, corresponding document	

EPO FORM 1503 03.92 (P0401)