



Europäisches Patentamt  
European Patent Office  
Office européen des brevets



Publication number: **0 519 125 A1**

**EUROPEAN PATENT APPLICATION**

Application number: **91203153.1**

Int. Cl.<sup>5</sup>: **E04F 13/08, E04B 9/24**

Date of filing: **03.12.91**

Priority: **21.06.91 IT TO910474**

Date of publication of application:  
**23.12.92 Bulletin 92/52**

Designated Contracting States:  
**AT BE CH DE DK ES FR GB GR LI LU NL SE**

Applicant: **Fracas, Mario**  
**Via Netro No. 17**  
**I-10143 Turin(IT)**

Inventor: **Fracas, Mario**  
**Via Netro No. 17**  
**I-10143 Turin(IT)**

Representative: **Robba, Eugenio et al**  
**Studio "INTERPATENT" via Caboto 35**  
**I-10129 Turin(IT)**

**Modular-system support structure for modular panels.**

Support structure (21) composed of cross modular elements (1), each one composed of a core (3) from which four arms (5) depart, each arm being composed of a first thin part (9), of a second bigger part (11) and of a third L-bent part (13) which has a fixing cleft (15) as wide as the thin part (9), these arms (5) being connected each other by a continuous segment (7), circumference type. In this structure (21) adequate modular panels (23), or "tile" elements, can be applied by fixing: they are composed of a basic element (25) from which a plurality of stems (27) protrude, normally to it, stems that can be inserted by fixing into the structure (21).

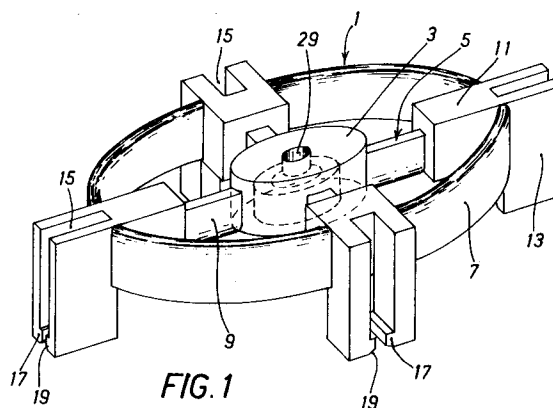

**EP 0 519 125 A1**

The present invention relates to a modular-system support structure for modular panels, particularly to a continuous fixing structure for said support for said panels.

It is known that it has been often attempted to solve the problem of composing structures with modular elements, with the most different purposes and means.

Object of the present invention is realizing a modular support structure, that can be applied to a wall, structure into which panels, that are modular too, can be inserted in order to realize in said wall the desired coating and with panels that are also modular.

The advantages that can be obtained with said structure are essentially:

- ease of construction for the structure, thanks to the mutual fixing of modular elements;
- ease of application of the constructed structure to the wall;
- ease of placing on said wall as many modular elements or panels as desired, in such a way as to realize a certain coating with a given ornamental drawing.

The above and other purposes and advantages of the invention, as they will appear from the following description, are reached thanks to a plurality of cross modular elements, each one of which is composed of a core from which four arms depart, each arm being composed of a first part with thin section, of a second part with bigger section, and of a third part, or fixing part, of the same dimensions, that is L-bent and has a cleft whose length is equal to the thickness of the first part; said third parts, or fixing parts, being connected each other by a continuous segment, or circumference, at the center of which the above-said core is present.

The modular panels that can be applied to said carrying structure are composed of a basic element or tile element from whose base a plurality of stems protrude, normally to it, stems that are adequately located, suitable to be inserted by fixing on the thin parts of the arms and on the continuous segment connecting the same ones of the above-described modular fixing elements; the arrangement for the carrying structure with fixed modular elements allowing inserting into it a plurality of said modular coating panels or tiles, until the wall coating is completed and realizing the desired ornamental drawing.

The invention will now be described with particular reference to the accompanying drawings, supplied as a not limiting example, in which:

- Fig. 1 is a perspective view of the modular element of the structure;
- Figure 2 is a plan view of the structure element of Fig. 1;
- Figure 3 is a side elevation view of the struc-

ture element of Fig. 1;

- Figure 4 is a side elevation view indicating two fixed structure elements and a third detached element, next to being fixed into the group formed by the first two ones;
- Figure 5 is a plan view of a modular structure realized according to the invention;
- Figure 6 is a rear plan view of a "tile" element;
- Figure 7 is a side elevation view of the "tile" element in Fig. 6; and
- Figure 8 is a plan view of a modular structure into which the tile element is inserted.

As it appears from the figures, the basic modular element, suitable to form the carrying structure with other similar elements, is indicated by numeral 1 and is composed of a core 3 from which four arms 5 depart, that are mutually connected by a continuous segment 7, circumference, that is coaxial with said core 3.

Each one of said arms 5 is composed of a first part 9 with thin section, of a second part 11 with bigger section, and of a third part 13, or fixing part, with the same dimensions, that is L-bent and has a cleft 15 whose width is equal to the thickness of part 9.

The two half-bodies 13 forming the cleft 15 ends at their distal end with two prongs 17, facing inside, that are normal to the cleft 15, and chamfered in 19.

In order to understand the function of the above-described basic element 1, it is mandatory to refer to Figure 4, where the mutual fixing of three of said basic elements 1 is schematically indicated.

Said fork elements 13 of each element 1 become fixed in part 9 of the other element, thus creating a double fixing between said elements 1.

Suffice it to say that to each basic element 1, straight placed, four basic elements 1, reverse placed, must be fixed and that on each of said four basic elements 1, reverse placed, other four basic elements 1, straight placed, must be fixed, and so on, in order to generate a carrying structure 21, as wide as needed.

An example of this carrying structure 21, composed in such a way, is indicated in Figure 5.

The insertion of covering modular panels 23, tile type, is provided into a carrying structure thus composed.

The modular panels 23 that can be applied to said carrying structure 21 are composed of a basic element 25, or tile element, from whose base 25 a plurality of stems 27 protrude, normally to it, stems that are suitable to be inserted by fixing into the thin parts 9 of the arms 5 and into the continuous segment 7 connecting said arms 5.

In order to enable said fixing, as it appears

from Figure 8, each one of said panel elements 23 must be inserted into the structure 21 rotated by 45° with respect to the basic element 1; only in this way said stems 27 will be inserted both into the thin parts 9 of the arms 5 and on the continuous segment or circumference 7 connecting said arms.

It is clear that the external part of the tile element 23 will have its own ornamental drawing; the combination of the plurality of said drawings for said tiles inserted into the structure generating a global ornamental drawing, variable also depending on how said tiles 23 have been arranged in the structure itself.

Here following there are important advantages, that can be obtained from a modular carrying structure according to the invention:

- a "normal", mechanical, insertion of said tile elements 23 into the structure 21, without the need of looking for specialized operators;
- the possibility of changing said tile elements 23 in a safe way, without touching the carrying structure 21, that can be easily secured to the wall to which it is aimed through adequate securing means (not shown), inserted into the suitable holes 29 provided in the cores 3 of the modular elements 1.

It is clear that the invention is not limited to the execution way that has been described and illustrated, but that several modifications and further improvements can be carried out on it without going out of the scope and field of the invention.

## Claims

1. Modular-system support structure (21) for modular panels, characterized in that it is composed of a plurality of cross modular elements (1), each one of which is composed of a core (3) from which four arms (5) depart, each arm being composed of a first part (9) with thin section, of a second part (11) with bigger section, and of a third part (13), or fixing part, of the same dimensions, that is L-bent and has a cleft (15) whose length is equal to the thickness of the first part (9); said third parts (13), or fixing parts, being connected each other by a continuous segment (7), or circumference, at the center of which the above-said core (3) is present.
2. Modular-system support structure (21) for modular panels according to claim 1, characterized in that the modular panels (23) that can be applied to said structure (21) are composed of a basic element (25) or tile element, from whose base (25) a plurality of stems (27) protrude, normally to it, stems that are ade-

quately placed, and suitable to be inserted by fixing into the thin parts (9) of the arms (5) and into the continuous segment (7) connecting the same ones of the modular fixing elements (1) described above; the disposition of the carrying structure (21) with fixed modular elements (1) allowing to insert into it a plurality of said modular coating or "tile" panels (23), until the wall coating is completed and realizing the desired ornamental drawing.

3. Modular-system support structure (21) for modular panels (23) according to claim 1, characterized in that the continuous segment (7) connecting the arms (5) of the modular element (1) is a circumference.
4. Modular-system support structure (21) for modular panels (23) according to claim 1, characterized in that the continuous segment (7) connecting the arms (5) of the modular element (1) is a regular polygon.

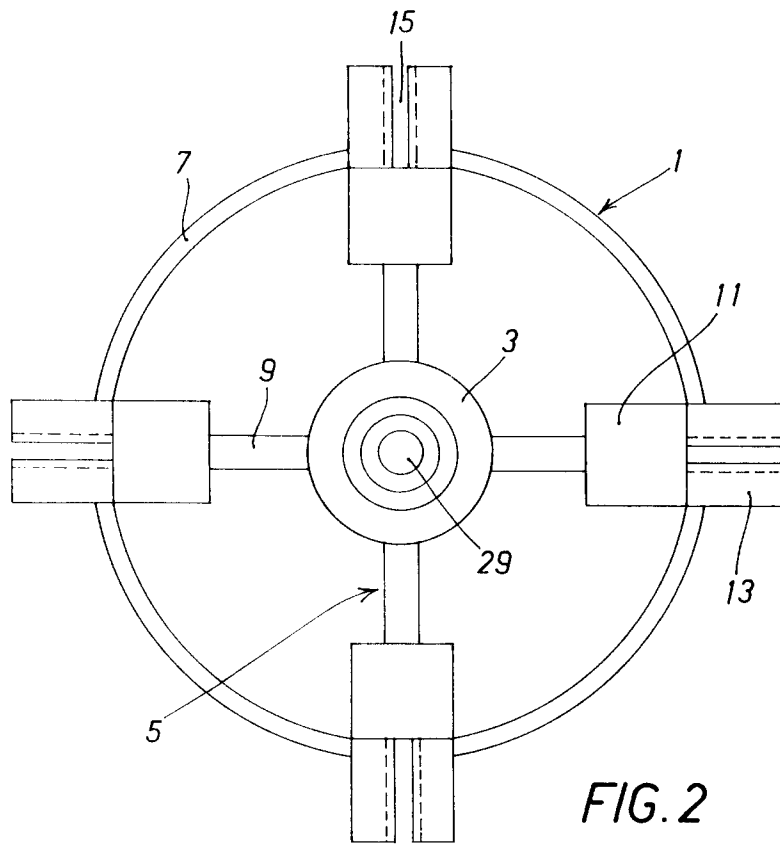
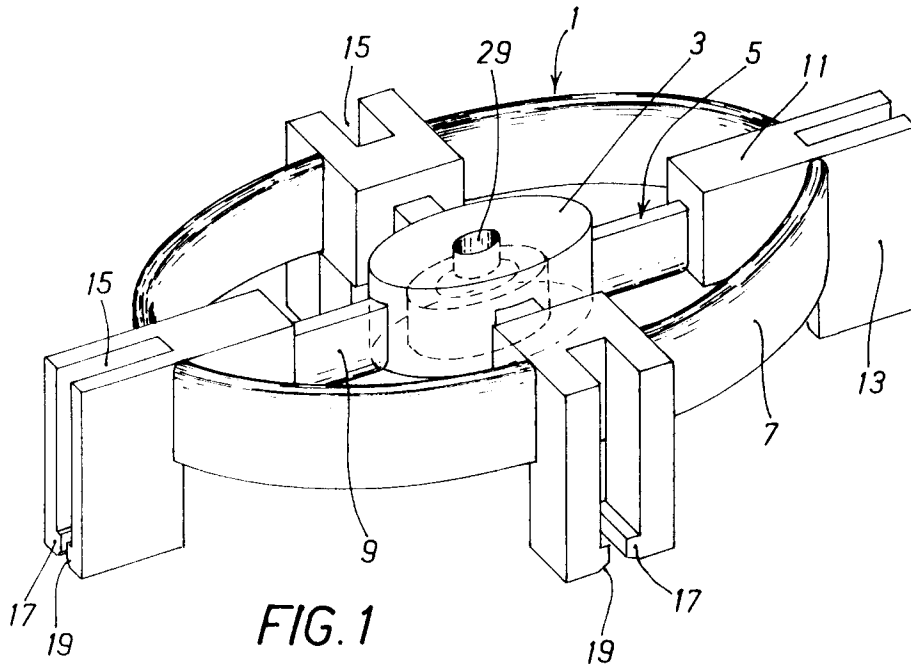

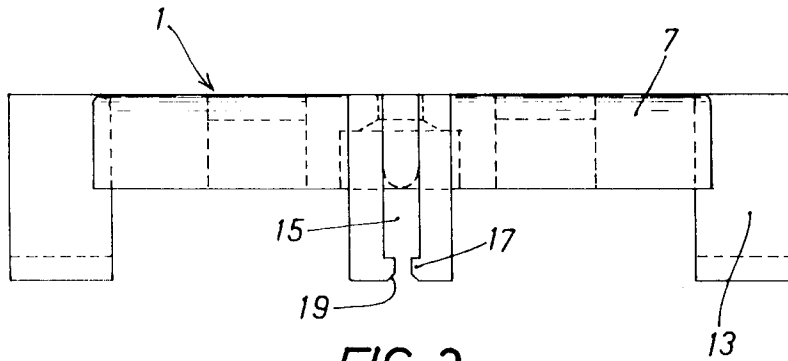

FIG. 3

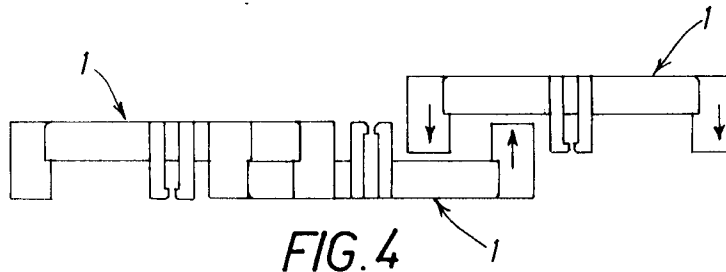

FIG. 4

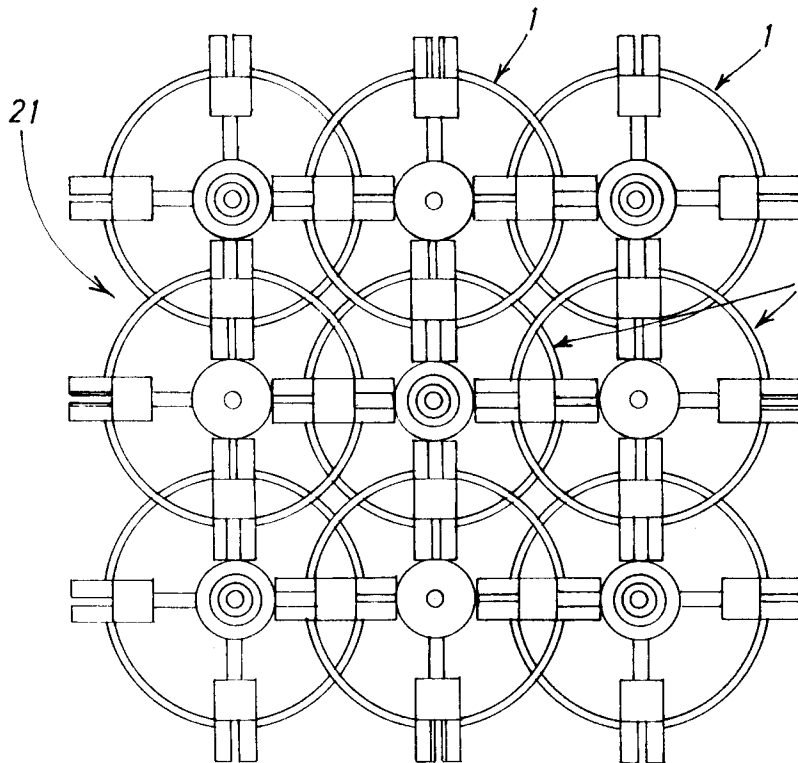

FIG. 5

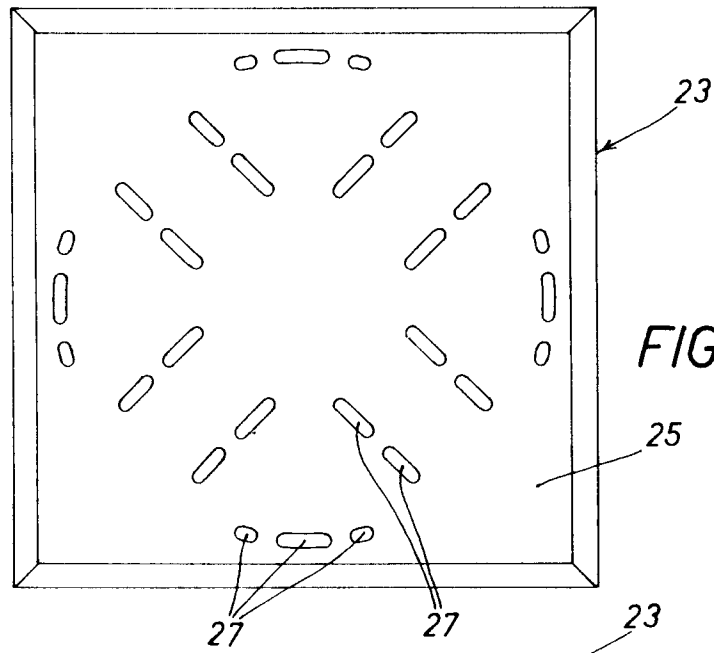

FIG. 6

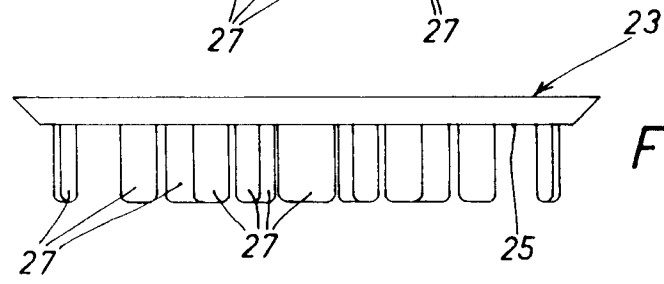

FIG. 7

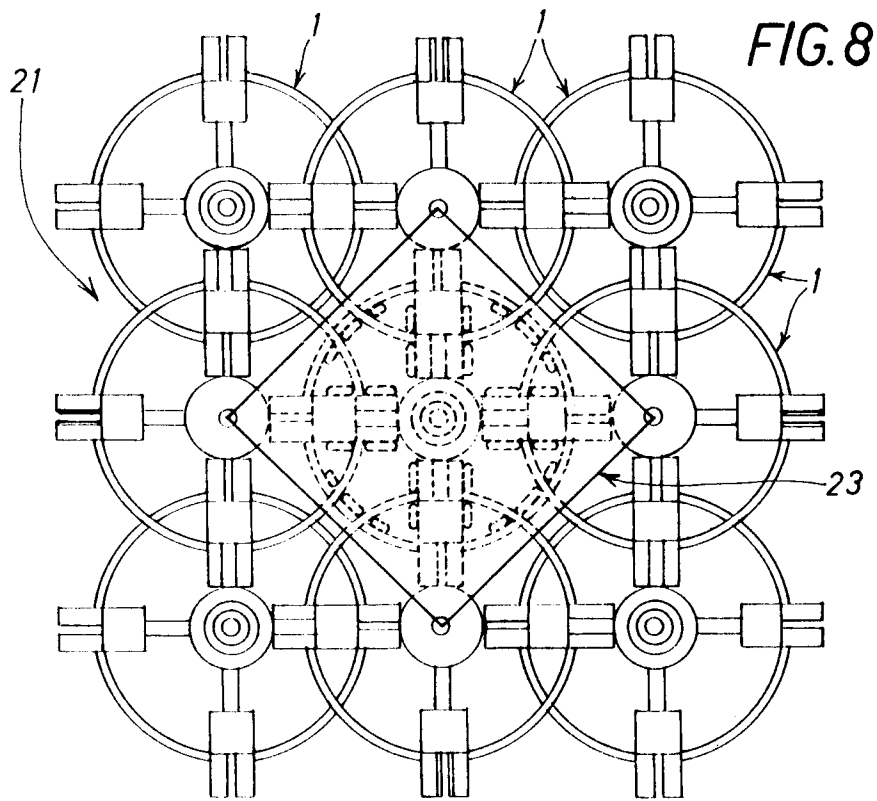

FIG. 8



DOCUMENTS CONSIDERED TO BE RELEVANT			
Category	Citation of document with indication, where appropriate, of relevant passages	Relevant to claim	CLASSIFICATION OF THE APPLICATION (Int. Cl.5)
A	GB-A-1 390 513 (GIBBS) * page 2, line 60 - page 4, line 1; figures 1-9 *	1, 2, 4	E04F13/08 E04B9/24
A	DE-A-3 801 765 (STARP) * column 5, line 12 - column 8, line 19; figures 1-23 *	1, 2	
A	DE-A-3 633 914 (MIELKE) * the whole document *	1, 2, 4	
A	DE-A-3 639 930 (MIELKE) * the whole document *	1, 2, 4	
A	FR-A-345 753 (PARKINSON) * page 1, line 36 - page 2, line 50; figures 1-11 *	1	
			TECHNICAL FIELDS SEARCHED (Int. Cl.5)
			E04F E04B E01C E04D F16B
The present search report has been drawn up for all claims			
Place of search THE HAGUE		Date of completion of the search 22 JULY 1992	Examiner AYITER J.
CATEGORY OF CITED DOCUMENTS		T : theory or principle underlying the invention E : earlier patent document, but published on, or after the filing date D : document cited in the application L : document cited for other reasons ..... & : member of the same patent family, corresponding document	
X : particularly relevant if taken alone Y : particularly relevant if combined with another document of the same category A : technological background O : non-written disclosure P : intermediate document			