



Europäisches Patentamt
European Patent Office
Office européen des brevets



Publication number: **0 527 506 A2**

EUROPEAN PATENT APPLICATION

Application number: **92113930.9**

Int. Cl.⁵: **E21B 10/52**

Date of filing: **14.08.92**

Priority: **14.08.91 US 744777**
26.09.91 US 766882
26.11.91 US 798435

Date of publication of application:
17.02.93 Bulletin 93/07

Designated Contracting States:
DE FR GB IT

Applicant: **SMITH INTERNATIONAL, INC.**
16740 Hardy Street
Houston, Texas 77032(US)

Inventor: **Siracki, Michael A.**
21807 N. Tangle Creek Lane
Spring, Texas 77388(US)
Inventor: **Minikus, James C.**
2846 Chios
Costa Mesa, California 92626(US)
Inventor: **Portwood, Gary R.**
22007 Kenlake Drive
Katy, Texas 77450(US)
Inventor: **Cawthorne, Chris E.**
3 Cattail Place
The Woodlands, Texas 77381(US)

Representative: **Patentanwälte Grünecker,**
Kinkeldey, Stockmair & Partner
Maximilianstrasse 58
W-8000 München 22 (DE)

Tungsten carbide inserts for rock bits.

A tungsten carbide chisel insert for rolling cone rock bits has a cylindrical base section and a cutting tip section, the top of the tip section having an elongated or chisel crest. The remainder of the cutting tip section below the crest is formed having cross-sections having no non-tangential intersections along their outer periphery. Such an insert used on the gage of a rock bit has a larger nose radius at the outer end of the insert crest than at the inner end, thereby providing more mass on the portion of the insert that contacts the borehole sidewall. Another chisel insert has a crest with a "dog bone" shape rounded with the crest ends flaring out to a larger dimension than the middle thereof. The crest is also convex upwardly along its median line, thereby making a shorter moment arm at the ends of the crest.

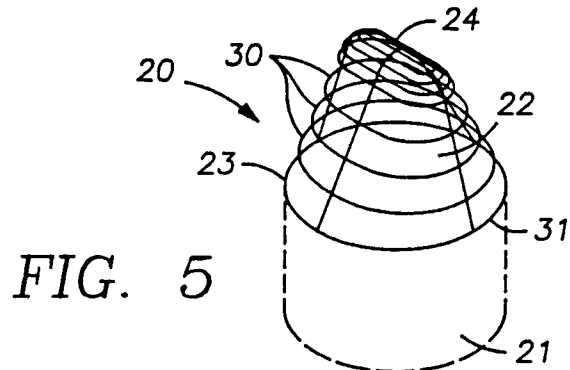

EP 0 527 506 A2

Background

This invention relates generally to tungsten carbide insert rock bits of the rolling cutter type and more particularly to the specially shaped and designed inserts utilized thereon.

Rock bits using sintered tungsten carbide inserts generally have a wedge or chisel-shaped configuration for soft to medium hard formations. Various embodiments of such configurations are shown in U.S. Patent No. 3,442,342. Such chisel-shaped inserts conventionally have a cylindrical base and frustoconical projecting body. A typical body has its outermost extremity forming a curvilinear crest and a pair of flanks generally converging toward the crest. In all forms of chisel type inserts, blended intersections are provided to avoid the sharp corners and sharp edges which cause high stress concentrations which contribute to the chipping and breaking thereof. Such blended intersections conventionally have radii of 0.090 inches or less.

However, even with such extensive blending of surface intersections, these intersections are still considered to be areas of high stress concentration due to the fact that such intersections were non-tangential. This is because flat portions of the insert intersect with the curved sections.

Another problem with such inserts is that the large contact areas are susceptible to heat checking, resulting in premature wear and breakage. Insert heat checking can be defined as high cycle thermal fatigue due to intermittent frictional heat generated by borehole wall to gage insert contact and subsequent cooling by drilling fluid per each revolution.

Other patents, such as U.S. Patent No. 4,108,260, show specially shaped inserts which aid in the lifting of cuttings in the borehole, but these inserts suffer from the same shortcomings because of the flank portions intersecting non-tangentially with the curved portions of the inserts.

U.S. Patent No. 4,832,139 shows an inclined chisel insert having different cone angles on opposite sides of the crest. The advantage of such an insert is that it provides a relatively small area of contact with the borehole wall thereby being less prone to frictional heating.

Another type of insert is shown in U.S. Patent No. 4,086,973. Although this insert is not a gage insert, it does show an inclined crest positioned to contact the formations with substantially its entire length.

However, when the flanks of the insert have a common plane perpendicular to them both, the end of the crest that cuts the hole wall generally tends to wear quickly due to the reduced volume of insert material in that region.

These prior art designs also had equal outer and inner corner radii extending beyond the ends of the crests. This type of structure causes the outer ends of the inserts to wear faster than otherwise desirable, therefore leading to premature undergauge conditions.

In operation, as the cutter or cone rotates, the crest initially contacts the formation at a time when the longitudinal axis of the insert is non-perpendicular with respect to the hole bottom. Bending stresses are thus generated in the inserts, tending to cause breakage.

This is particularly true in the drive row of the cutters, the first row of inserts inboard of the gage row. Drive row inserts experience more chipping and breaking initiating at the corners of the insert crest.

To alleviate this breakage problem, the nose radius has been made larger across the entire crest length. Although such blunter inserts have been successful in reducing breakage, they have also functioned to reduce the rate of penetration of the bit.

The inner row inserts of U.S. Patent No. 3,442,342 had slightly convex crests and flanks which intersected to enable the crest to have a uniform width. The patent further states that if the flanks were flat, the natural intersection with the crest would create a crest of non-uniform width, thin at the middle and flaring out to a larger dimension at each end. Such a crest was considered to be undesirable because if the center dimension were large enough to avoid breakage, the ends would also be so wide that the tip would be dull at those locations, and conversely, if the ends were thinned down to a sharp width, the center part of the crest would be so fragile as to invite early breakage.

Another prior art insert is shown in U.S. Patent No. 4,254,840. This insert includes a cutting tip made primarily of a truncated cone having a hemispherical tip mounted thereon. The sides of the sphere are tangential to the conical surface. A pair of flats are then placed into the sides of the cutting tip.

The problem with such an insert is that the radius of the cutting tip is constant and relatively large thereby functioning to reduce the rate of penetration.

Brief Summary of The Invention

The present invention obviates the above-mentioned shortcomings by providing a specially shaped insert for a rolling cone rock bit having no non-tangential intersections.

The base section of such an insert is generally cylindrical and adapted to extend into a matching

hole formed in a cone of the bit, the longitudinal axis of the base forming the axis of the insert. The upper end of the cutting tip section furthest away from the base section comprises an elongated crest transverse to the insert axis. At least one end of the crest has a radius in a plane normal to the surface of the insert which is larger than the radius of another portion of the crest remote from the end of the crest.

In an exemplary embodiment the crest is radiused along the length of the crest and normal to the length of the crest and at the ends of the crest, with the radius forming the crest normal to its length being smallest at the middle of the crest and becoming larger as it reaches the ends of the crest. This enables the ends of the crest to have a larger mass than the middle to better absorb the higher loads acting on the outside corners of the crest. The "dog bone" crest is convex along its median line which makes the actual insert extension less at the crest corners thereby making a shorter moment arm in a location where impacts are more frequent.

In some embodiments, the cutting tip includes a pair of convex surfaces formed at the opposite ends of the crest. One convex surface has a steeper angle than the other convex surface. The shallower convex surface and/or larger radius end is employed adjacent to the wall of a borehole being drilled. The steeper angle of the convex surface enables the crest to remain as long as conventional insert crests while still providing the desired gage surface angle.

Preferably, a smooth transition is made between the base of the insert and the crest. More specifically, the base of the insert tip has a circular cross-section while the crest is elongated. A series of contour curves are between the crest and the base. Each contour curve is of continuous shape having no non-tangential intersections requiring a blend radius. The contour curves become smaller in size and more elongated as they approach the crest.

A particular advantage of the present invention is that not only does the insert not have areas of high stress concentration, it also has reduced cross-sectional areas proceeding down the insert compared to a conventional chisel. This enables the insert to be sharper at all cross-sections in the cutting tip, allowing it to penetrate deeper into the formation as well as enabling the insert to remain sharper initially and as it is being worn down.

Brief Description Of The Drawings

The above noted features and advantages of the present invention will be more fully understood upon a study of the following description in con-

junction with the detailed drawings, wherein:

FIG. 1 is an isometric view of a conventional prior art chisel insert;

FIG. 2 is a top elevational view of the prior art chisel insert;

FIG. 3 is a side elevational view of the prior art chisel insert;

FIG. 4 is a front elevational view of the prior art chisel insert;

FIG. 5 is an isometric schematic view of an insert showing the contour curves utilized in the construction of an insert made in accordance with the present invention;

FIG. 6 is a top elevational schematic view of the insert of FIG. 5;

FIG. 7 is a side elevational schematic view of the insert of FIG. 5;

FIG. 8 is a front elevational schematic view of the insert of FIG. 5;

FIG. 9 is an isometric view of another embodiment of insert;

FIG. 10 is a top elevational view of the insert shown in FIG. 9;

FIG. 11 is a side elevational view of the insert shown in FIG. 9;

FIG. 12 is a front elevational view of the insert shown in FIG. 9;

FIG. 13 is a front elevational view of the prior art chisel insert showing where the section lines 13 A to 13 G are taken, and FIGS. 13 A to 13 G are sectional views taken from respective sections of the insert of FIG. 13;

FIG. 14 is a front elevational view of the insert of the present invention showing where the section lines 14 A to 14 G are taken, FIGS. 14 A to 14 G are sectional views taken from respective sections of the insert of FIG. 14;

FIG. 15 is a graphical representation comparing a prior art insert to the insert of the present invention, plotting cross-sectional area versus depth of penetration;

FIG. 16 is an isometric view of another embodiment of the present invention;

FIG. 17 is a top elevational view of the embodiment illustrated in FIG 16;

FIG. 18 is a side elevational view of the embodiment illustrated in FIG 16;

FIG. 19 is a front elevational view of the embodiment illustrated in FIG. 16;

FIG. 20 is a perspective view of a wedge crested inclined chisel insert of the present invention;

FIG. 21 is a top elevational view of the wedge crested inclined chisel insert;

FIG. 22 is a side elevational view of the wedge crested inclined chisel insert;

FIG. 23 is a side elevational view of the wedge crested inclined chisel insert;

FIG. 24 is a bottom hole profile of a rock bit utilizing a wedge crested inclined chisel insert;
 FIG. 25 is an elevational view of another embodiment of the present invention;
 FIG. 26 is a top elevational view of the embodiment of FIG. 25;
 FIG. 27 is a side elevational view of the embodiment of FIG. 25;
 FIG. 28 is a front elevational view of the embodiment of FIG. 25;
 FIG. 29 is an elevational view of a still another embodiment of the present invention;
 FIG. 30 is a top elevational view of the embodiment of FIG. 29;
 FIG. 31 is a side elevational view of the embodiment of FIG. 29;
 FIG. 32 is a front elevational view of the embodiment of FIG. 29;
 FIG. 33 is a perspective view of another embodiment of a chisel crested insert made in accordance with the present invention;
 FIG. 34 is a top elevational view of the insert of the embodiment illustrated in FIG 33;
 FIG. 35 is a side elevational view of the embodiment illustrated in FIG. 33;
 FIG. 36 is a front elevational view of the embodiment illustrated in FIG. 33;
 FIG. 37 is a perspective view of a final embodiment of the present invention;
 FIG. 38 is a top elevational view of the embodiment of FIG. 37;
 FIG. 39 is a side elevational view of the embodiment of FIG. 37; and
 FIG. 40 is a front elevational view of the embodiment illustrated in FIG. 37.

Description

Referring now to the drawings FIGS. 1 to 4 illustrates a conventional, prior art, chisel-shaped insert 10 having a cutting tip portion 11 and an integral base portion 12, the latter being typically cylindrical and both parts being centered about an axis 13 of the base.

The cutting tip 11 of insert 10 has its outermost extremity formed with a curvilinear crest 14 having a median line 15 which divides the crest 14 into two equal and symmetric halves. In addition, a plane through the longitudinal axis 13 and the median line 15 of the crest 14 divides the entire insert into two halves symmetric in such plane. The cutting tip also has a pair of flanks 16 disposed at equal angles to the plane of symmetry and axis, 45° as illustrated or a 90° included angle between flanks 16. Thus, the flanks generally converge toward the crest. The balance of the cutting tip is a conical surface symmetric about the axis which forms an included angle of approximately 160°

with the outer surface of the base.

The crest is round in the direction along its median line 15 and it is also rounded in the direction athwart its median line, as shown by the curves 17 and 18. The smaller curve 17 is tangent to the flanks, while the larger curve 18 is tangent to the conical surface in a plane through the insert center line 13 and median line 15 only.

The flanks can be flat or could also be rounded, being convex outwardly. In addition to the described curves and rounds, the intersections 19 of the flanks with the conical surface are also preferably blended or rounded.

All of the above described curves and rounds are incorporated in the inserts prior to sintering, either in the pressing mold or by grinding the pressed green insert before it is sintered.

FIGURES 5 through 8 illustrate schematically the insert made in accordance with the present invention. The insert, generally indicated by arrow 20 includes a cylindrical base 21, shown in broken lines. This base construction is conventional in nature and is similar to the base construction 12 of the prior art insert shown in FIGS. 1 through 4.

The novel construction lies in the cutting tip portion 22. This construction comprises a circular base 23 formed at its lower end while the upper end terminates with a crest 24. The crest is characterized by the fact that the crest is rounded along the median line 25 having a given radius 26. In addition, the ends 27 of the crest are also rounded having a radius 28 which is the same as radius 26 and is also tangent to the conical surface in all planes.

The median line divides the crest and the rest of the cutting tip into two equal and symmetric halves. In addition, a plane 29 through the longitudinal axis of the insert and the median line divides the cutting tip into two halves symmetric in such plane.

A plurality of horizontal contour curves 30 are located between the crest 24 and the circular base, each contour curve being continuous in cross-section. The lowermost contour curve 31 more closely approximates a circle while each ascending contour curve becomes smaller and more elongated to approximate the cross-section of the tip of the crest. In this preferred embodiment, the maximum change in the slope between any two points, approximately 5% of the perimeter apart, on the contour curve is 40°.

FIGURES 9 through 12 show the insert 20 in its final construction. The cutting tip 22 comprises an outer surface shaped to conform to the shape formed by the contour curves 30 and the crest 24.

It should be noted from this construction that there are no flat portions intersecting with curved portions to form high stress areas. In fact, there are

no non-tangential intersections at all in transitioning from the circular cross-section of the base to the oval cross-section of the crest.

FIGURES 13 and 14 illustrate the point that the insert made in accordance with the present invention is a sharper insert, prior to and during wear, than a conventional prior art insert. FIGURES. 13 A-G show the various cross-sections of the prior art insert 10 taken along the planes indicated in FIG. 13. FIGURES 14 A-G show the same cross-sections of the insert 20 of the present invention taken along the planes indicated in FIG. 14. As can be seen, even though there are no flats in the new insert, the convex surfaces of insert still enable the insert to have a smaller cross-sectional area than the prior art insert 10 at the various planes. As stated earlier, this enables the new insert to be sharper initially and as it is dulled than the prior art insert, while still having higher strength attributes because of having less stress risers. It also allows the insert to penetrate deeper into the formation, providing a faster rate of penetration.

FIGURE 15 illustrates graphically the cross-sectional area comparison between the prior art insert 10 and the insert 20 of the present invention. Each insert was the size to fit onto a 17-1/2 inch rock bit and both had the same base cross-sectional area. The depth of penetration illustrated means the distance from the crest of the insert to the base. As can be seen, the cross-sectional area of the new insert 20, shown in a solid line, is smaller than the prior art insert 10, shown in broken lines, at nearly all depths of penetration.

FIGURES 16 through 19 illustrate another embodiment of the present invention. This embodiment shows an asymmetrical insert 40 having a cylindrical base 41 and a cutting tip 42. The cutting tip is at its outermost extremity formed with a crest 43 that is located to the one side of the insert axis.

The transition from the crest 43 to the base 41 is again accomplished with a plurality of contour curves that become generally larger as they descend. However, it should be noted that there is not a straight line relationship from the crest to the base. The contour curves are sized and oriented to shift the mass to the trailing edge 44 and have the leading edge 45 have a concavity formed thereon. The basic construction is somewhat similar to the insert shown in U.S. Patent No. 4,108,260 with the exception that the crest is not on the longitudinal axis. Moreover, the insert preferably does not have any planar or straight surfaces forming the leading and trailing edge. The insert with its continuously curved cross-sections extending down the insert from the crest, has smooth non-tangential intersections in order not to create high stress areas.

As can be seen, a chisel insert made in accordance with the present invention can have various

shapes, be symmetrical or asymmetrical, and still have the smooth blending of all surfaces never before attained.

Special configurations of rock bit insert are usable on the gage row of a cone, that is, the row that is nearest the wall of the borehole as it is being drilled.

FIGURES 20 to 21 illustrate such an embodiment of the present invention comprising a wedge crest inclined chisel insert, generally indicated by arrow 120. The insert includes a cylindrical base 121 centered about the axis of the insert. The insert further includes a cutting tip 122 which is adapted to extend out of the surface of the cone. The cutting tip has its outermost extremity forming a wedge shaped crest 123 having ends 124 and 125. End 124 is formed by a radius extending therearound and is adapted to be oriented on the cone to face inwardly away from the hole wall surface. One end 125 is formed by a larger radius than that of the opposite end 124 of the crest to form a larger mass at the end 125 which is to be oriented on the gage row of the cone to face and engage the hole wall surface.

The remaining portion 126 of crest is tapered from the large radiused end 125 down to the small radiused end 124 and is formed by constantly descending radii extending from a radius equalling that at the larger end 125 to a radius equalling that at the smaller end 124.

The cutting tip further includes a pair of convex surfaces 127 and 128 formed at the opposite ends of the crest. One convex surface 127 has a steeper angle than the other convex surface 128. Preferably, these angles are 14° and 28° respectively. The shallower convex surface 128 is adapted to be oriented to face and engage the hole wall surface. The steeper angle of the convex surface 127 enables the crest 123 to remain as long as conventional insert crests while still providing the desired gage surface angle.

The remaining surface 129 of the tip is completed by contouring the wedged shaped crest gradually toward the base. In fact, the entire cutting surface of the cutting tip 122 has no non-tangential intersections.

FIGURE 24 illustrates the bottom hole rock bit profile showing the location of the chisel insert 120 being on the gage row of a cone 150. As is conventional, all of the inner rows of inserts 151 from all three cones are superimposed on the figure. The cone 150 also conventionally includes a plurality of heel row inserts 152 located thereon adjacent the hole wall.

As can be seen, the insert 120 is oriented to have the enlarged radiused end 125 of the crest 123 contact the borehole wall surface 153. The enlarged end is typically about 50% larger than the

inner end radius. As the insert wears, the crest length is reduced but still adequate to support the insert at an advanced state of wear. The additional mass of material located at that end enables the insert to wear more slowly. In addition, the enlarged radiused end 125 functions to reduce the stress level acting thereon to prevent the inserts from cracking or chipping.

FIGURES 25 to 28 illustrate another embodiment of the present invention comprising a wedge crest inclined chisel insert generally indicated by arrow 130. This embodiment is similar to the insert described in U.S. Patent No. 4,832,139, with the exception that the crest of the present invention is tapered.

The insert 130 comprises a cylindrical base 131 and a cutting tip portion 132. The outermost extremity of the cutting tip forms a crest 133 that is substantially similar to the crest 123 of the previous embodiment.

The crest includes a small radiused end 134 and a larger radiused end 135 that are adapted to be oriented in the same manner as ends 124 and 125, respectively. The portion of the crest between the ends is similarly tapered at 136.

The cutting tip 132 further includes a pair of conical surfaces 137 and 138 formed at opposite ends of the crest 133 with the conical surface 137 having a steeper cone angle than conical surface 138. The conical surface 137 is adapted to be oriented inwardly, away from the borehole wall while the conical surface 138 is adapted to be oriented to face and engage the borehole wall surface.

A pair of flanks 139 are formed between the conical surfaces 137 and 138 and extend between the crest and down to the base. The flanks are substantially flat.

FIGURES 29 to 32 illustrate still another embodiment of the present invention comprising a wedge crest inclined chisel insert generally indicated by arrow 140. This embodiment is similar to the second embodiment with the exception that the crest is inclined rather than being horizontal.

The insert 140 includes a base 141 and a cutting tip 142. The outermost extremity of the cutting tip forms a crest 143 having an elevated inner end 144 and a relatively lower outer end 145. The crest is again tapered along 146.

Like the other embodiments, the insert 140 is inclined by having a steeper conical surface 147 and borehole wall engaging conical surface 148. A pair of flanks 149 are also being formed on the cutting tip between the conical surface 147 and 148.

The crest 143 is radiused the same as the crests of the other embodiments and because the crest is tilted downwardly to intersect the plane of

the conical end 148 at a lower point than the other end, it naturally tapers outwardly as it approaches that end 148.

As a result, all of these embodiments provide an inclined chisel insert having a tapering crest that adds wear material at the area where it is needed most, and deletes material where it is not needed to maintain sharpness. These crests are also all rounded and radiused across their entire lengths to reduce the stress levels throughout.

FIGURES 33 through 36 illustrate schematically an insert made in accordance with the present invention. The insert, generally indicated by arrow 50 includes a cylindrical base 51. The novel construction lies in the cutting tip portion 52. This construction comprises a circular base 53 formed at its lower end adjacent to the cylindrical base of the insert, while the upper end terminates with a crest 54. The crest 54 is rounded with respect to its median line rather than being flat or parallel with the median line.

The cutting tip also has a pair of flanks 56 generally converging toward crest 54 with the balance of the cutting tip being a conical surface 55.

The crest 54, the flanks 56 and the conical surfaces 55 intersect in such a manner that the crest forms a "dog bone" configuration, i.e., a non-uniform width, thin at the middle and flaring out to a larger dimension at each end.

The crest is rounded or radiused along and athwart the median line to blend in with the flanks and the conical surfaces. The radius forming the crest is smallest at the middle at 57 and becomes larger as it reaches the ends at 58. This varying crest or nose area allows the higher loaded areas on the outside corners of the crest to have the larger mass to counteract such loads.

Moreover, since the crest is also convex along its median line, the actual insert extension is less at the crest corners thereby making a shorter moment arm in a location where impacts are more frequent.

This dog bone configuration to resembles the preceding embodiment in that one end of the crest has a radius in a plane normal to the surface of the insert which is larger than the radius of another portion of the crest remote from the end of the crest. In the previous embodiment, the smaller radius crest is at the end opposite from the larger radius portion. In the dog bone configuration, the smaller radius portion is in the middle and each end of the crest has a larger radius.

FIGURES 37 through 40 illustrate another embodiment of the dog bone shaped insert. This embodiment is similar to the first embodiment except that the flanks are not utilized and the areas between the conical surfaces are substantially convex.

This embodiment includes a tungsten carbide insert, indicated by arrow 60, having a base section 61 and a cutting tip section 62. The nose or top portion of the cutting tip forms a crest 64 which is convex with respect to its median line and rounded or radiused along its length thereof and at its ends.

The rest of the cutting tip is formed by convex surfaces 66 extending from the ends of the crest 64 to the base section 61.

The area 66 between the convex surfaces 65, forming the remainder of the cutting tip section, is substantially convex as it extends from the base section 61 and approaches the crest 64.

The crest of the second embodiment of dog bone insert is similar to that shown in the first embodiment in that it is shaped like a "dog bone", i.e., a non-uniform width, thin at the middle and flaring out to a larger dimension at each end. The crest 64 is rounded or radiused athwart the median line with the radius being smaller at the middle at 67 and becoming larger as it reaches the ends at 68.

The portions 69 of the areas 65 just below the crest are slightly convex in order to intersect with the dog bone crest. The convex areas 66 transition with the convex surfaces 65. As a result, the cutting tip section 62 has no non-tangential intersections between the various surfaces to avoid any high stress areas thereon.

It will of course be realized that various modifications can be made in the design and operation of the present invention without departing from the spirit thereof. Thus, while the principal preferred construction and mode of operation of the invention have been explained in what is now considered to represent its best embodiments, which have been illustrated and described, it should be understood that within the scope of the appended claims, the invention may be practiced otherwise than as specifically illustrated and described.

Claims

1. A shaped insert for a rolling cone rock bit having a base section and a cutting tip section, the base section being generally cylindrical and adapted to extend into a matching hole formed in a cone of the bit, the longitudinal axis of the base forming the axis of the insert, the upper end of the cutting tip section furthest away from the base section comprising an elongated crest transverse to the insert axis, and characterized by at least one end of the crest having a radius in a plane normal to the surface of the insert which is larger than the radius of another portion of the crest remote from the end of the crest.
2. An insert as recited in claim 1 wherein the crest is radiused along the length of the crest and normal to the length of the crest and at the ends of the crest, with the radius forming the crest normal to its length being smallest at the middle of the crest and becoming larger as it reaches the ends of the crest, thereby enabling the ends of the crest to have a larger mass than the middle to better absorb the higher loads acting on the outside corners of the crest.
3. An insert as recited in claim 1 wherein the remainder of the cutting tip surface below the crest is formed with an outer surface adjoining both the crest and base section, the elongated crest having a rounded concave exterior surface with the second end having a smaller radius than the first mentioned end.
4. An insert as recited in any of the preceding claims wherein the remainder of the cutting tip section comprises a convex surface section under each end of the crest, the convex surface section under the first end having a steeper angle than the convex surface section under the second end.
5. An insert as recited in any of the preceding claims wherein the elongated crest is substantially normal to the cylindrical axis of the base section.
6. An insert as recited in any of the preceding claims wherein the elongated crest extends at an acute angle to the axis of the base section, whereby the crest is inclined so that the first end is higher than the second end.
7. An insert as recited in any of the preceding claims wherein the crest is convex upwardly with respect to the median line whereby the actual insert extension is less at the ends of the crest, thereby making a shorter moment arm at a location where impacts are more frequent.
8. An insert as recited in any of the preceding claims wherein the cutting tip section further includes a convex surface extending under and blending with each end of the crest and a flank on each side of the crest between the convex surfaces, the flanks blending with the sides of the crest so that the crest has an enlarged radius at each of its ends.
9. An insert as recited in any of the preceding claims wherein the convex surfaces of the cut-

ting tip section extends downwardly from the elongated crest to the base section, the convex surfaces having no non-tangential intersections with the crest and the base section.

- 5
- 10.** A shaped insert for a rolling cone rock bit having a base section and a cutting tip section, the base section being generally cylindrical and adapted to extend into a matching hole formed in a cone of the bit, the longitudinal axis of the base forming the axis of the insert, the upper end of the cutting tip section furthest away from the base section comprising an elongated crest substantially normal to the insert axis, and characterized by the remainder of the cutting tip section below the crest being formed with an outer surface having cross-sections normal to the insert axis having no non-tangential intersections along their outer periphery. 10
15
20
- 11.** The insert as recited in Claim 10 wherein the crest has an outer surface formed by a radius along a line normal to the insert axis, and a radius formed at the outer ends thereof, the radii being tangential to each other and as well as to the outer surface of the cutting tip. 25
- 12.** An insert as recited in either of claims 10 or 11 wherein the cross-sections of the cutting tip outer surface are substantially oval. 30
- 13.** An insert as recited in any one of claims 10 to 12 wherein the cross-sections become progressively larger and more closely approximate a circle as they approach the base section of the insert. 35
- 14.** An insert as recited in any one of claims 10 to 13 wherein the cross-sections are sized and oriented with respect to the insert axis to provide the cutting tip section with a concave leading edge and a convex trailing edge. 40
- 15.** An insert as recited in any one of claims 10 to 14 wherein the remainder of the cutting tip section below the crest is formed with an outer surface having cross-sections normal to the insert axis shaped to have a continuous curve in which the maximum change in the slope between any two points on the surface approximately five percent of the perimeter apart is 40°. 45
50

55

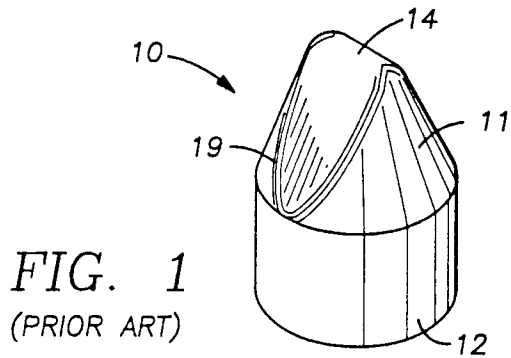

FIG. 1
(PRIOR ART)

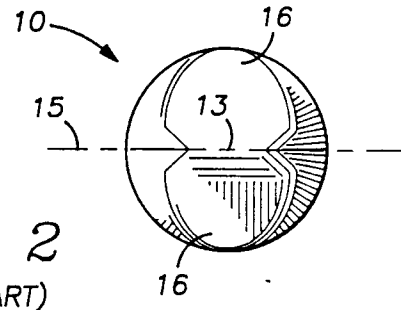

FIG. 2
(PRIOR ART)

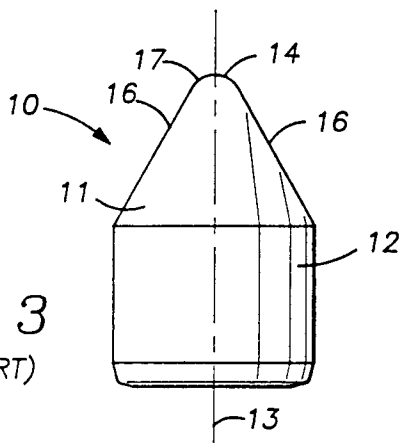

FIG. 3
(PRIOR ART)

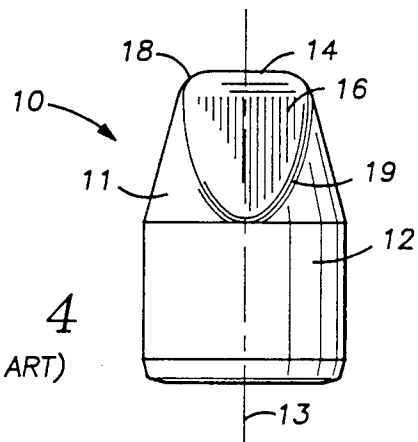

FIG. 4
(PRIOR ART)

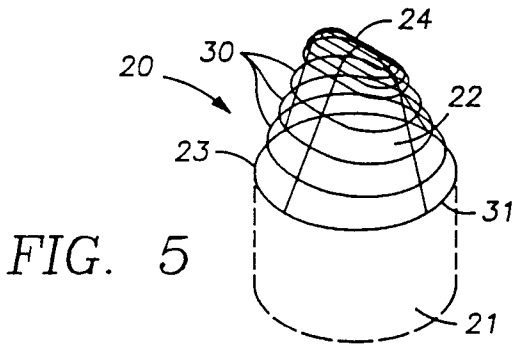

FIG. 5

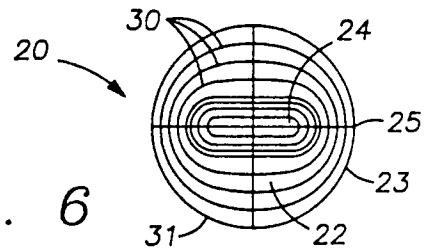

FIG. 6

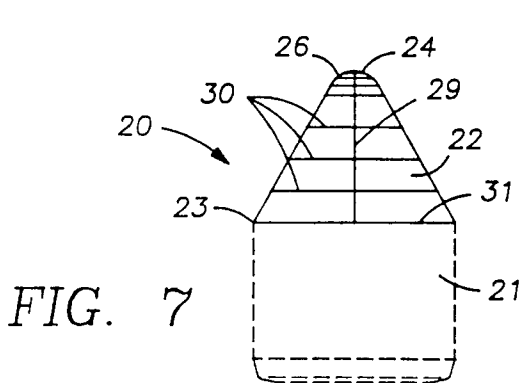

FIG. 7

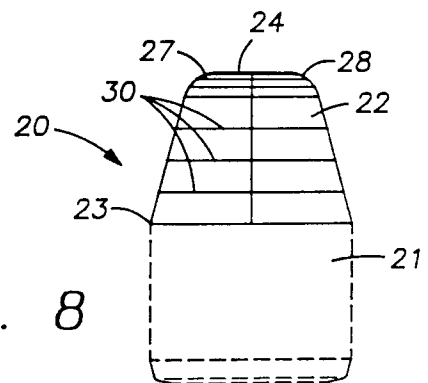
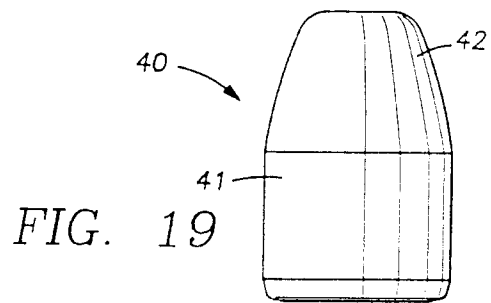
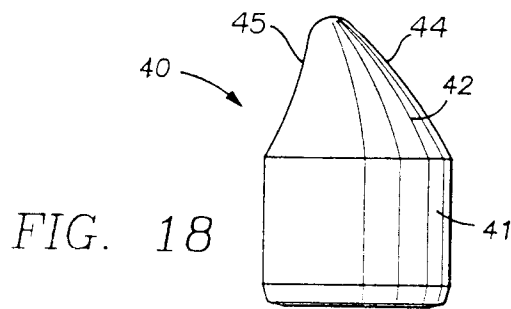
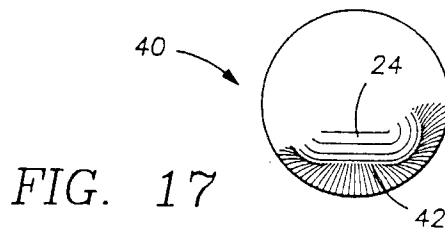
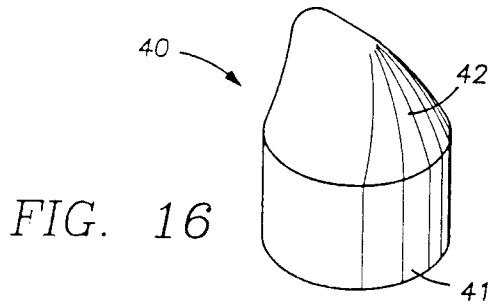
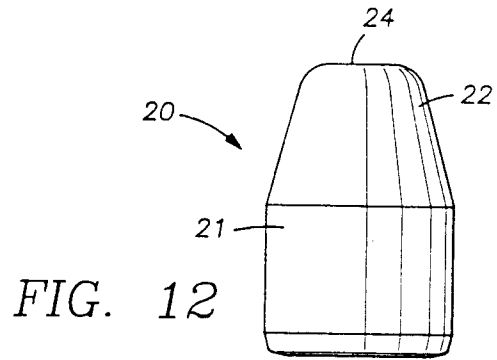
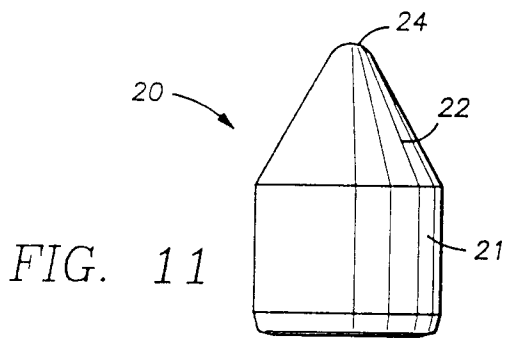
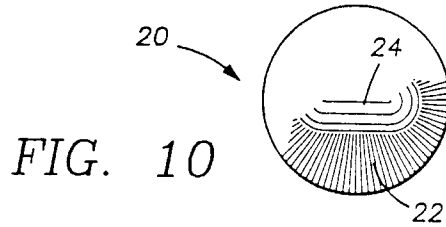
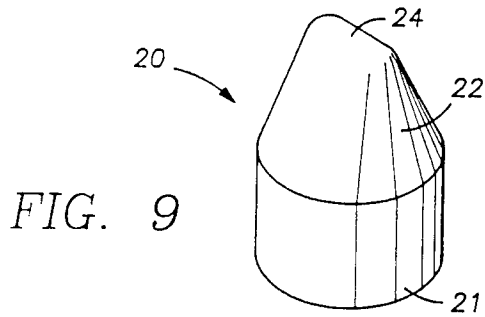
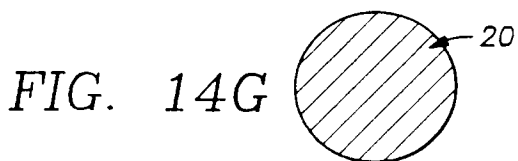
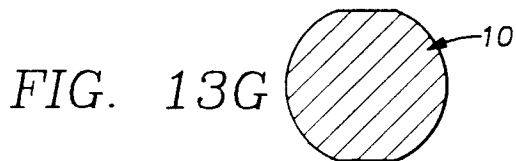
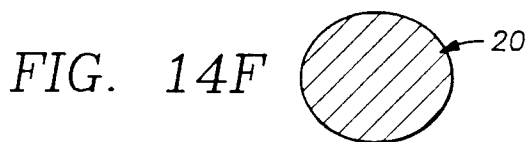
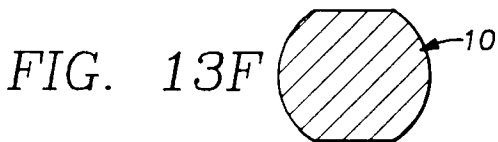
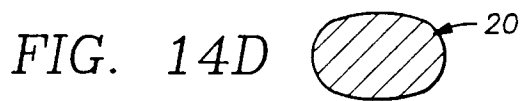
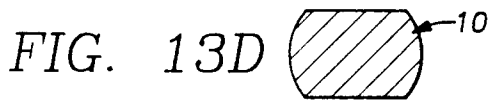
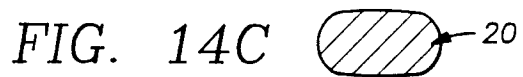
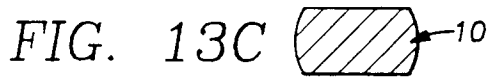
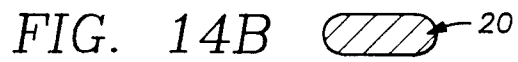
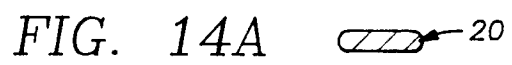
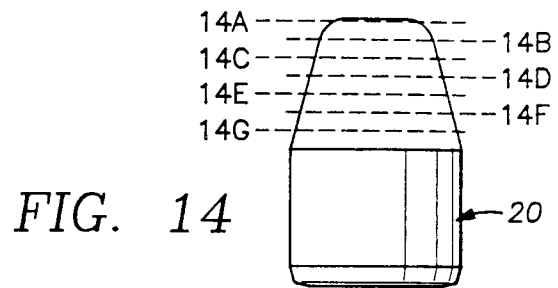
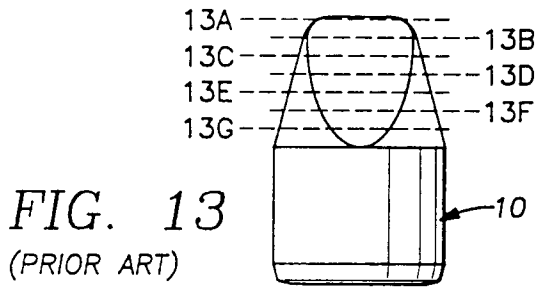

FIG. 8





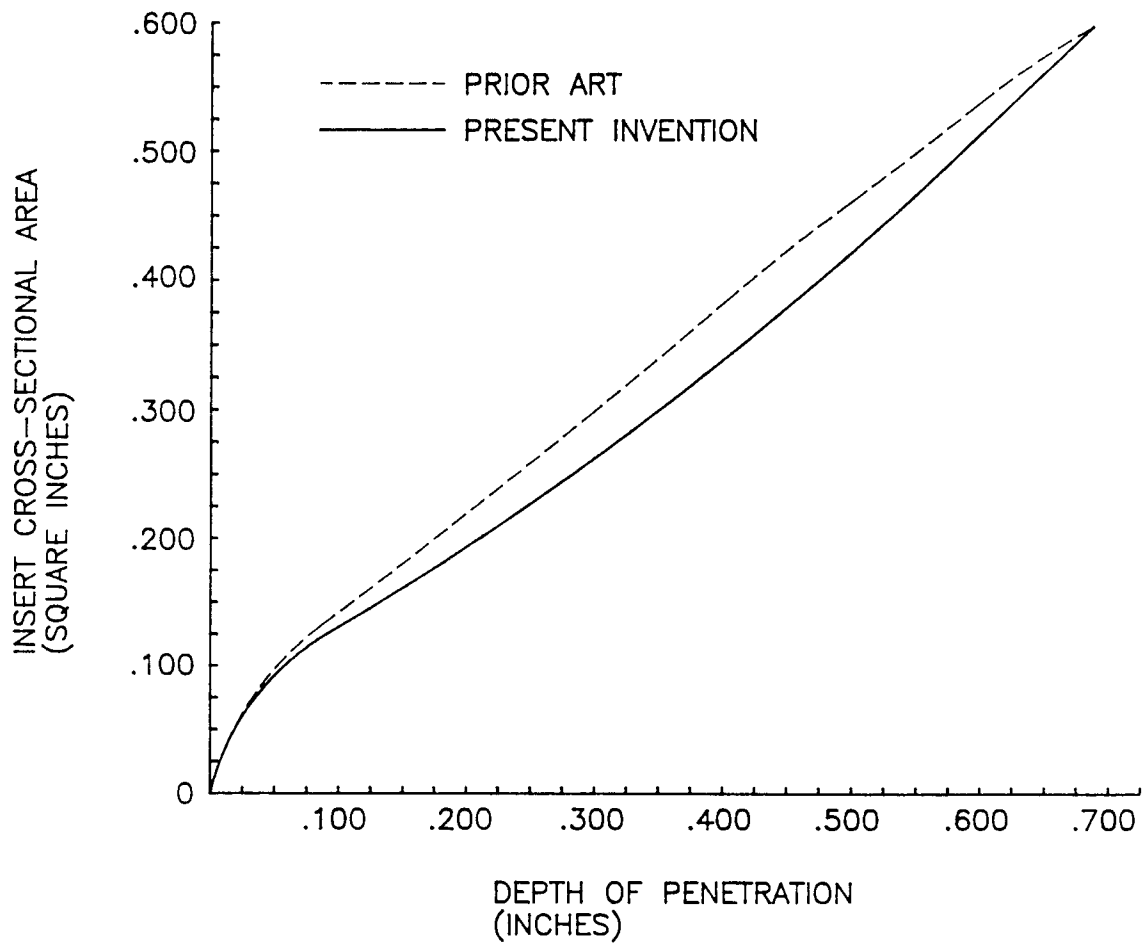

FIG. 15

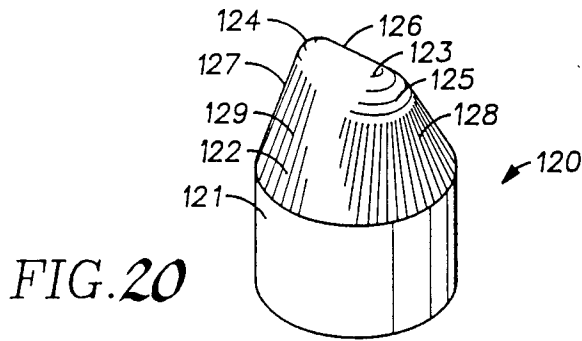

FIG. 20

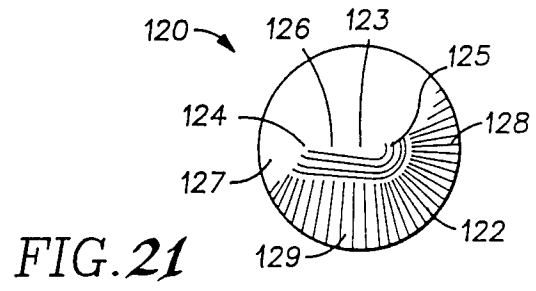

FIG. 21

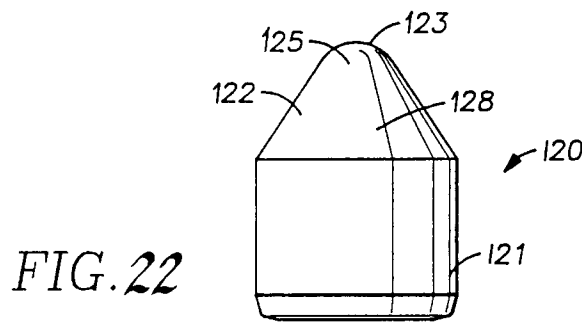

FIG. 22

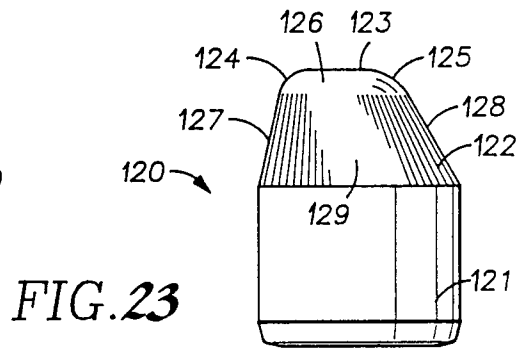

FIG. 23

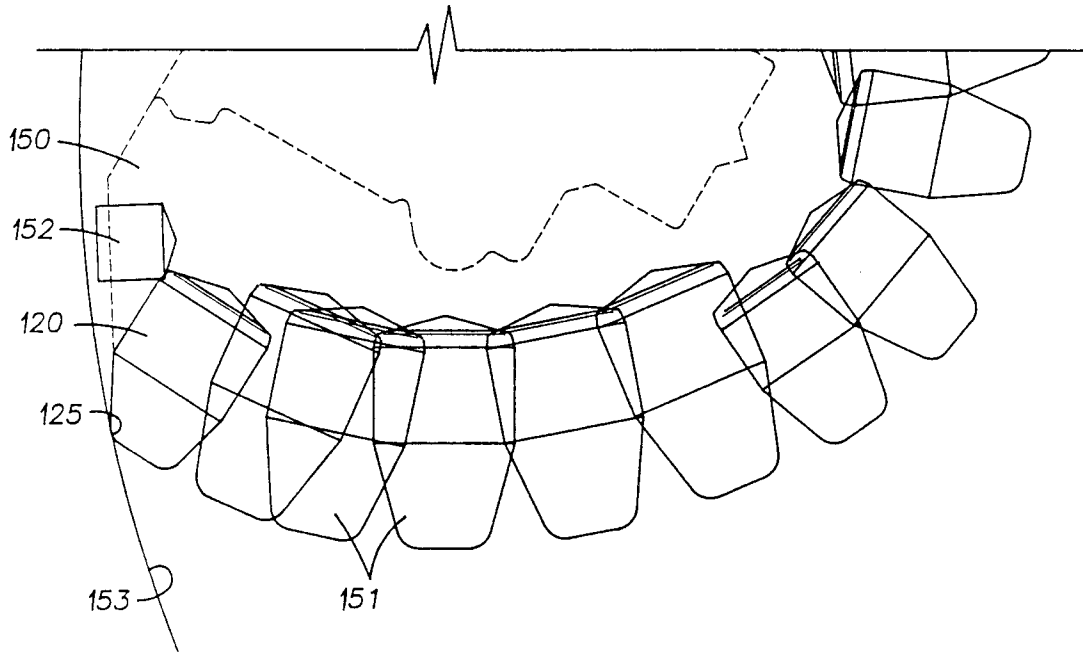

FIG. 24

