



EUROPEAN PATENT APPLICATION

Application number : **92308049.3**

Int. Cl.⁵ : **H02M 7/5395, H02M 7/797, H03K 7/08**

Date of filing : **04.09.92**

Priority : **06.09.91 US 755920**

Inventor : **Blasko, Vladimir**
75 Highgate Road, Apartment B-4
Newington, Connection 06011 (US)

Date of publication of application :
10.03.93 Bulletin 93/10

Representative : **Tomlinson, Kerry John**
Frank B. Dehn & Co. European Patent
Attorneys Imperial House 15-19 Kingsway
London WC2B 6UZ (GB)

Designated Contracting States :
DE ES FR GB IT

Applicant : **OTIS ELEVATOR COMPANY**
10 Farm Springs
Farmington, CT 06032 (US)

Pulse-width-modulation method for providing extended linearity, reduced commutation losses and increase in inverter/converter output voltage.

The invention relates to voltage conversion devices, whether for inversion or conversion includes a pulse-width-modulator 3 and a three-phase, three-legged bridge, each leg 56,58,60 of the bridge having a pair of complementary switches (S1/S1*, S2/S2*, S3/S3*). One of the switches S1, S2 or S3 (S1*, S2* or S3*) conducts in those time intervals where the associated reference voltage UA UB or UC has a higher (smaller) amplitude than the other two reference voltages. According to the present invention, (a) three reference voltages UA, UB, UC are supplied, (b) the maximum of these voltages is detected, (c) the maximum is subtracted from the peak value UTP of a triangle wave used for forming the PWM signal, and (d) the difference is added to each of the reference voltages UA,UB,UC to form augmented reference voltages UA',UB',UC' supplying a PWM.

The result is that when one of the three reference voltages is greater than the other two, a switch of one of the three complementary pairs, both switches open and close in response to the PWM signal such that only two currents are independently controlled by each of the two complementary pairs which are allowed to open and close.

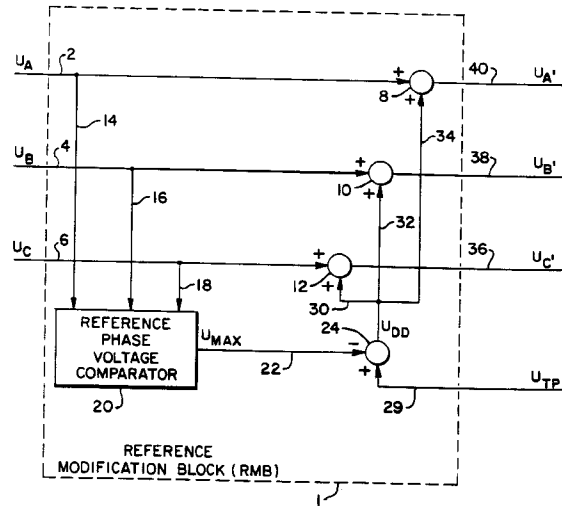

FIG. 1A

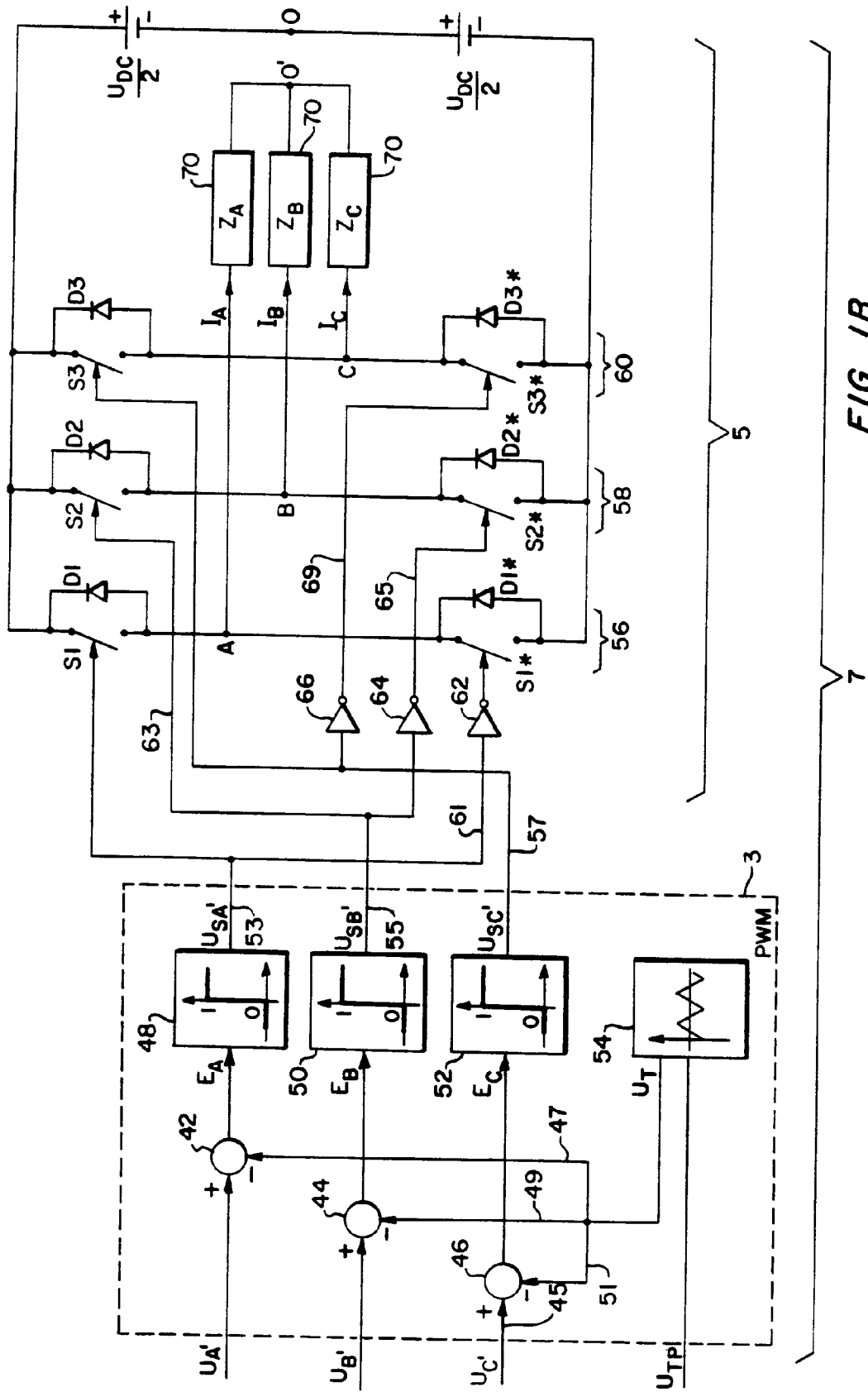

FIG. 1B

This invention relates to PWM voltage conversion.

In one and three-phase voltage source inverters and converters, alternating voltage is generated usually from a constant DC bus voltage by switching on and off semiconductor switches in a bridge according to a PWM technique. The PWM technique which is very often used is based on the comparison of a triangular voltage with fixed frequency and a reference voltage with fixed or variable frequency (triangle comparison method).

A single-phase PWM converter consists of a PWM circuit (with control electronics), a semiconductor bridge, an AC voltage source in series with an inductor, and a load on the DC side. Because the load in a voltage source inverter (VSI) can be substituted with an inductor in series with an AC voltage source, the circuit topology for a VSI applies equally well for a voltage source converter (VSC). A single-phase PWM circuit typically consists of a triangle signal generator, a summer, and a comparator. The triangle signal generator produces a triangle signal U_T having a carrier frequency f_c , the peak values of the triangle being $+U_{TP}$ and $-U_{TP}$. U_T is subtracted from a reference phase voltage U_A , in the summer, producing an error signal E_A , which is provided to the comparator. In response, the comparator produces a switching signal U_{SA} , that controls two complementary switches S1, S1*.

The bridge circuit, which receives the PWM signals for controlling S1 and S1*, consists of two circuits having the load in common. One circuit consists of a switching assembly, including a switch S1 and a freewheeling diode shunting that switch, a DC power supply having a voltage $\frac{U_{dc}}{2}$, and a third element, the load. The second loop consists of a second switching assembly, including a switch S1* responsive to a NOT gate and a freewheeling diode shunting the switch, a second DC power supply having a voltage $\frac{U_{dc}}{2}$, and a third element, the load. The two circuits apply a voltage of magnitude $\frac{U_{dc}}{2}$ across the load Z_A . When S1 is closed, the polarity of the voltage is opposite the polarity when S1* is closed. If $E_A > 0$ or $U_A > U_T$, the output U_{SA} of the comparator assumes a value equal to 1. The first switch S1 is now closed and the second S1* opened. The voltage $U_{A'O}$ across the load, between the line midpoint and the supply midpoint, is $\frac{U_{dc}}{2}$. On the other hand, if $E_A < 0$, or $U_A = U_T$ the output U_{SA} of the comparator is zero. The switch S1* is now closed and the first switch S1 is opened. A negative voltage $U_{A'O} = -\frac{U_{dc}}{2}$ is applied across the load Z_A .

When U_A is positive, over a period $\frac{1}{f_c}$ the switching

voltage U_{SA} is equal to 1 for a time longer than it is equal to 0, and so S1 is closed more of the time and S1* less of the time; the average value of load voltage

$U_{A'O}$ is positive. When U_A is 0, U_{SA} (over a period $\frac{1}{f_c}$)

is 1 for the same amount of time as it is 0, S1 is closed for the same amount of time as it is open, and S1* is correspondingly open for the same amount of time as it is closed; the average load voltage $U_{A'O}$ is 0. When

U_A is a negative, U_{SA} (over a period $\frac{1}{f_c}$) is 0 for a time

longer than it is 1, and S1* is closed more of the time than S1; the average load voltage is negative.

If the carrier frequency f_c is much higher than the frequency f_R of the reference signal U_A , the locally averaged supply phase voltage across the load mostly follows the reference phase voltage U_A . An amplitude modulation index m_A is defined as a ratio of the peak value of sinusoidal reference voltage U_A and peak value U_{TP} of the triangular voltage U_T . The average load voltage within each period of the triangle wave is a locally averaged voltage U_{AOLAVR} and tracks U_A so long as the magnitude of U_A is less than U_{TP} .

To the extent that the locally averaged voltage U_{AOLAVR} tracks U_A , the inverter output is a linear function of its input U_A . The peak value of $U_{AOLAVR} = m_A * \frac{U_{dc}}{2}$, as long as the modulation index m_A is smaller

than 1. For a modulation index m_A equal to 1, the maximum locally averaged voltage U_{AOLAVR} is applied to the load, and the saturation limit of the PWM circuit is reached. Accordingly, $m_A \leq 1$ provides a linear system while $m_A > 1$ provides a non-linear system. Stated differently, the locally averaged voltage U_{AOLAVR} follows U_A , so long as $|U_{TP}| \geq |U_A|$. Further increase in the reference voltage U_A , is not followed by a proportional increase of the load voltage $U_{A'O}$.

The analysis for a three-phase inverter is similar because it is simply the sum of three single-phase inverters.

For a three-phase system, the line voltage U_L is $U_P * \sqrt{3}$ times bigger than the phase voltage U_P . For a PWM inverter/converter with a triangular PWM technique, the peak value of the phase voltage that can be achieved is $U_P = \frac{U_{dc}}{2}$, and therefore the peak

line-to-line voltage, is equal to $(\frac{U_{dc}}{2}) * \sqrt{3}$.

The three-phase PWM inverter has problems. First, in the three-phase bridge, the peak value that the line voltage can reach is U_{DC} . This is 15.4% higher than $(\frac{U_{dc}}{2}) * \sqrt{3}$, the value that can be reached by the triangle comparison method. The possibility of increasing phase voltages by 15.4% without saturation, by applying different modulation techniques, is clear.

For an inverter, this means a 15.4% increase in output voltage. For a converter this means a 15.4% increase in the allowed input voltage. Second, saturation of the PWM circuit causes a reduction of gain in the voltage/current control loops using the PWM and deterioration of the dynamic characteristics of the inverter. Third, the PWM circuit produces commutation losses in proportion to the high carrier frequency f_c .

One method of providing both extended voltage range and reduced commutation losses is reported by Malesani, L. and Tenti, P., et al., "Improved Current Control Technique of VSI PWM Inverters with Constant Modulation Frequency and Extended Voltage Range", IEEE-IAS, Conference Record of the 1988 IEEE Industry Applications Society Annual Meeting 23rd. This method modifies conventional hysteresis current regulators. A hysteresis current regulator compares a current fed back from a phase current and provides a current error signal to a hysteresis comparator which provides PWM signals to complementary switches in a leg of a bridge. Malesani, L., et al., modifies conventional three-phase hysteresis to achieve an approximately 15% increase in inverter output voltage and regulates to reduce commutation losses by a factor of one-third, by performing modulations on only two inverter legs at a time, while the third stands at the positive or negative pole of the supply voltage. Phase current error beyond a hysteresis band is the index for determining which leg will stand.

Hysteresis regulators are not suitable for micro-processor software implementation because they require fast comparators which must change state in response to the controlled variables independently of the sampling intervals of the microprocessor. Hysteresis regulators are normally implemented in hardware.

In an inverter power conversion bridge, the invention recognizes that in linear operation of the triangle PWM method where the amplitude modulation index m_A is smaller than 1, the maximum line-to-line voltage U_L is equal to $(\frac{U_{dc}}{2}) * \sqrt{3}$ although the peak voltage across the bridge is U_{DC} . U_{DC} is 15.4% larger than $(\frac{U_{dc}}{2}) * \sqrt{3}$. The invention also recognizes that in the three-phase balanced system, $I_A + I_B + I_C = 0$; only two currents are independent, and the third can be controlled by controlling the other two. Given these two propositions, there are therefore time intervals when one of the pairs of complementary switches $S1/S1^*$, $S2/S2^*$, or $S3/S3^*$ can be kept closed or open, and all three currents will be controlled by two other pairs of complementary switches in active legs of the bridge, by controlling only two currents.

According to one aspect of the present invention, there is provided

a method of voltage conversion using a pulse-width-modulator and a bridge, said bridge including at least three legs, each including two complementary switches, comprising the steps:

5 providing a plurality of sinusoidal reference signals, displaced one from another by a phase angle, one associated with each leg;

detecting a maximum magnitude of said sinusoidal reference signals for providing a maximum reference signal;

10 subtracting said maximum reference signal from a signal of constant magnitude equal to the amplitude of a triangle carrier signal from said pulse width modulator, for providing a difference signal;

15 adding said difference signal to said sinusoidal reference signals for providing a plurality of augmented reference signals, one associated with each leg, to said pulse-width-modulator. The result is that when one of the three reference voltages is greater than the other two, a switch in one of the three complementary pairs of switches in the bridge conducts, while in each of the other two complementary pairs, both switches open and close in response to the PWM signal such that only two currents are independently controlled by each of the two complementary pairs which are allowed to open and close, and the third current, associated with the complementing pair which is not allowed to switch, is controlled by the other two. Keeping one switch in each leg closed for one-third of the period of the reference voltage allows control of all three load currents to be dictated by the switching in only two legs of the bridge. This method has several advantages.

35 First, this method increases the bridge output voltage, and therefore the power, by 15.4%. without distortion of the phase voltages, the load midpoint voltage (point O' , Fig. 1) being different from the midpoint of the supply voltage (point O , Fig. 1). Second, because the output voltage has increased 15.4% without distortion, the linear range of operation of the inverter is extended. Consequently, the reduction in gain in the control loops and deterioration of dynamics which accompany saturation of the PWM at $m_A = 1.0$ are not encountered until $m_A = 1.154$. Third, since one leg of the bridge constantly conducts and therefore does not commute for one-third of the period of the reference voltage, losses accompanying commutation are reduced by one-third. Finally, it can be readily implemented in hardware or software.

50 According to a second aspect there is provided a voltage conversion bridge including a pulse-width-modulator (PWM) and a bridge operatively connected to said PWM, said bridge including at least three legs, each including two complementary switches, comprising:

55 means for providing a plurality of sinusoidal reference signals, displaced one from another by a phase angle, one associated with each leg;

detecting means for detecting a maximum magnitude of said sinusoidal reference signals for providing a maximum reference signal;

subtracting means for subtracting said maximum reference signal from a signal of constant magnitude equal to the amplitude of a triangle carrier signal from said pulse width modulator, for providing a difference signal;

a summer for adding said difference signal to said sinusoidal reference signals for providing a plurality of augmented reference signals, one associated with each leg, to said pulse-width-modulator.

It is a first object of the invention to extend the linear operation of a three-phase, three-legged PWM power conversion bridge by making a 15.4% increase in the line-to-neutral voltage U_{AO} at which distortion occurs. This is accomplished by augmenting all three phase voltages applied to the PWM by the difference between a constant voltage and the greatest of the three phase voltages such that while a phase voltage is greatest, a switch in the leg associated with the greatest voltage is kept closed. With one switch in a leg closed for 120° , all three load currents are controlled by the closing and opening of the switches in the other two legs, and the voltage across the bridge equals U_{DC} , rather than $U_{DC} * \frac{\sqrt{3}}{2}$, as in the conventional triangle comparison method.

It is a second object to reduce commutation losses by one-third.

It is a third object to increase PWM power conversion bridge output voltage and power by 15.4%.

Without the present invention, to get a 15.4% increase in power requires a 15.4% increase in input current that requires more expensive semiconductor switches capable of handling increased current requirements. This current increase thus results in increased losses.

A preferred embodiment of the present invention will now be described by way of example only and with reference to the accompanying drawings, wherein

Fig. 1 is a block diagram representation of a circuit for implementing the present invention in a voltage source inverter;

Fig. 2 is a voltage v. time graph of a three-phase sinusoidal voltage, U_{ABC} . The amplitude modulation index m_A is less than 1;

Fig. 3 is a voltage v. time graph of a difference signal, U_{DD} . Figs. 2 and 3 are on a common time line and m_A is less than 1;

Fig. 4 is a voltage v. time graph of a three-phase sinusoidal voltage, U_{ABC} . The amplitude modulation index m_A is greater than 1;

Fig. 5 is a voltage v. time graph of a difference signal; U_{DD} . Figs. 4 and 5 are on a common time line and m_A is greater than 1;

Fig. 6 is a voltage v. time graph showing a refer-

ence phase voltage, $U_{A'}$, an augmented reference phase voltage $U_{A'}$, and a triangle signal, U_T for $m_A = .8$;

Fig. 7 is a voltage v. time graph of the PWM switching signal, $U_{SA'}$ for $m_A = .8$;

Fig. 8 is a voltage v. time graph of the locally averaged phase voltage $U_{AO'LAVR}$ across load Z_A and the locally averaged phase voltage $U_{AO'LAVR}$ for $m_A = .8$;

Figs. 9, 10, 11 are similar to Figs. 6, 7, and 8, except that $m_A = 1.154$; and

Fig. 12 shows a circuit for implementing the invention in a converter circuit.

Fig. 1 shows a circuit for implementing the invention. It includes a reference modification block (RMB) 1, a pulse-width-modulator 3, and a semiconductor bridge 5. The bridge 5 may be for inversion, DC to AC, or conversion, AC to DC. RMB 1 is responsive to three sinusoidal reference phase voltages U_A U_B U_C , a triangle voltage U_T , and produces three augmented reference phase voltages $U_{A'}$, $U_{B'}$, $U_{C'}$. U_A U_B and U_C are control signals; power in the inverter is obtained from two DC voltage sources $\frac{U_{dc}}{2}$. The three reference

phase voltages U_A U_B U_C are spaced 120° apart. The augmented reference phase voltages are spaced 120° apart. RMB 1 includes three summers 8, 10, 12, a reference phase voltage comparator 20, and a fourth summer 24 responsive to the positive peak magnitude U_{TP} of a triangle signal U_T . The negative peak magnitude of the triangle signal U_T is $-U_{TP}$. The three reference phase voltages U_A , U_B , U_C are provided to RMB 1 and on lines 2, 4, 6 to summers 8, 10, 12. The reference phase signals U_A, U_B, U_C are provided to a reference phase voltage comparator 20. In the reference phase voltage comparator 20, the magnitudes of each phase voltage U_A, U_B, U_C are compared and the greatest, U_{MAX} , is produced on a line 22 to a summer 24.

In Fig. 1, a constant voltage triangle peak value U_{TP} of triangle signal U_T is produced in PWM 3 and provided on line 29 to summer 24. In summer 24, the greatest voltage, U_{MAX} , produced by the reference phase voltage comparator 20 on line 22, is subtracted from the triangle peak signal U_{TP} , and the difference U_{DD} provided on lines 30, 32, 34 to summers 12, 10, 8. At the summers 8, 10, 12, the difference signal U_{DD} is added to each of the reference signals U_A, U_B, U_C , thus providing on lines 40, 38, 36 augmented reference signals $U_{A'}$ $U_{B'}$ $U_{C'}$ to PWM 3. The signal added to U_{MAX} may be any constant signal U_{BIAS} , but U_{TP} is used here.

In Fig. 1, PWM 3 contains three summers 42, 44, 46, three comparators 48, 50, 52, and a triangle signal generator 54. Each of the summers 42, 44, and 46 is responsive to the augmented reference phase voltages $U_{A'}$, $U_{B'}$, $U_{C'}$ on lines 40, 38, 36 and the triangle signal U_T provided by the triangle signal generator 54

onto lines 47, 49, 51. The triangle signal generator 54 also provides U_{TP} on line 29. The triangle signal U_T has an amplitude of $|U_{TP}|$ and is therefore bounded by $+U_{TP}$ and $-U_{TP}$. The summers 42, 44, 46 provide error signals E_A, E_B, E_C to comparators 48, 50, 52. If U_X (X is A, B, and C) is greater than U_T , the output of the associated comparator 48, 50, or 52 assumes a value $U_{SX} = 1$. Thus, the comparators 48, 50, 52 produce switch signals U_{SA}, U_{SB}, U_{SC} and provide them to the bridge 5. Bridge 5 includes three legs 56, 58, and 60.

In Fig. 1, each leg includes two complementary semiconductor switch assemblies. The first leg includes a switch S1, a freewheeling diode D1 shunting that switch, and a complementary switching assembly—a NOT gate 62, a switch S1*, and a freewheeling diode D1* shunting that switch. The second leg 58 includes a switch S2, a freewheeling diode D2 shunting that switch, and a complementary switching assembly—a switch S2*, a NOT gate 64, and a freewheeling diode D2* shunting that switch. The third leg 60 includes a switch S3, a freewheeling diode D3 shunting that switch, and a complementary switching assembly—a switch S3*, a NOT gate 66, and a freewheeling diode D3* shunting that switch.

The first, second, and third legs 56, 58, 60 of the bridge 5 are responsive to the switch signals U_{SA}, U_{SB}, U_{SC} , provided on lines 53, 55, 57. For example, if E_A is greater than zero or U_A is greater than U_T , the output of comparator 48 assumes a value $U_{SA} = 1$. Switch S1 is closed and S1* is opened.

For $m_A < 1$, the inputs U_A, U_B, U_C to the RMB 1 as well as to the reference phase voltage comparator 20 (U_A, U_B, U_C) are shown in Fig. 2. The uppermost portion of Fig. 2, the maximum of U_A, U_B and U_C , is shown in bold as U_{MAX} . The triangle peak signal U_{TP} , provided on line 29 by the triangle generator 54 in the PWM 3, is shown. Figs. 2 and 3 are on a common time line and are divided into three sections "A", "B", "C".

The difference signal U_{DD} , produced by the summer 24 and equal to the difference between U_{TP} and U_{MAX} , is shown in Fig. 3. U_{DD} causes U_o to vary. U_o is the potential difference between the load midpoint o' and the supply midpoint o . The importance of recognizing this is seeing that the invention, because of U_{DD} , increases the locally averaged load phase voltage $U_{AO'LAVR}$ by 15.4% and, at the same time, allows distortion in the locally averaged voltage U_{AOLAVR} between line and supply midpoint (point 0 in Fig. 1), but removes distortion from the locally averaged phase load voltage $U_{AO'LAVR}$ between the line and the load midpoint. For an inverter, the supply is the DC bus voltage U_{DC} . In other words, for the 15.4% increased voltage range, distortion is transferred from where it matters, the load, to where it does not matter, U_{AO} . Without the RMB 1, $U_{AO} = U_{AO}'$, but with the RMB 1, they differ in proportion to U_{DD} .

The arrows in Fig. 2 represent the magnitude and sense of the alteration of U_A and U_B and U_C on lines

2, 4, 6 produced in the summers 8, 10, 12 to achieve U_A and U_B and U_C on lines 40, 38, 36. U_A and U_A' are shown in Figs. 6 and 9.

Fig. 3 is a voltage v. time graph of a difference signal, U_{DD} . Figs. 2 and 3 are on a common time line and m_A is less than 1.

Fig. 4 is a voltage v. time graph of a three-phase sinusoidal voltage, $U_{A,B,C}$. The amplitude modulation index m_A is greater than 1.

Fig. 5 is a voltage v. time graph of a difference signal, U_{DD} . Figs. 4 and 5 are on a common time line and m_A is greater than 1.

Fig. 6, on a voltage v. time graph, shows the triangle voltage U_T , the reference phase voltage U_A , and the augmented reference phase voltage $U_{A'}$. The graphs of U_A and $U_{A'}$ and U_T are similar for the other two reference phase voltages U_B and U_C but shifted 120° and 240° , respectively. The graph of $U_{A'}$ in Fig. 6 is divided into five sections: "A", "B", "C", "A", "B". These sections are analogous to those in Figs. 2 and 3 where three sections were shown. In the sections labeled "A", U_A is the greatest of the three phase voltages; the addition of U_{DD} causes U_A to be equal to U_{TP} and U_{SA} to be equal to 1. During "A", the switches S1 and S1* in the leg associated with U_A do not open and close with f_c . The switch S1 is closed in response to U_{SA} and S1* is open. The complementary switches in legs 2 and 3 may switch at frequency f_c of the triangular voltage U_T , but not those in leg 1.

In the sections labeled "B", the reference phase voltage U_B is the greatest of the three voltages, and the effect of the addition of U_{DD} on the phase voltage U_A , resulting in $U_{A'}$, is shown. The effect on U_B is the same as that upon U_A in section "A". While U_B is the greatest, switch S2 is closed and switch S2* open. The complementary switches in legs 1 and 3 may open and close, but not those in leg 2.

In section "C", the voltage U_C is the greatest of the three phase voltages, and the switch S3, in the leg of the bridge 5 associated with the phase voltage U_C , is closed. The complementary switches in the first and second legs of the bridge 5 are allowed to open and close, but not those in leg 3.

Fig. 7 shows the switching signal U_{SA}' in a voltage v. time graph on a time line common with Figs. 6 and 8. While U_A is the largest of the three voltages, switch S1 is always closed and conducting. While phase voltage U_B is the largest of the three, switch S1 and its complement S1* and switches S3 and S3* are switching. Similarly, 120° later, S3 conducts while S1, S1*, S2, and S2* switch.

Fig. 8, on a voltage v. time graph, shows the locally averaged voltage U_{AOLAVR} and the locally averaged load phase voltage $U_{AO'LAVR}$. U_{AOLAVR} is the time-average of voltage between points o and o' in Fig. 1. Prior art PWM circuits would become non-linear in section "A" where the reference voltage U_A exceeds the magnitude of the triangle signal U_{TP} . According to

the invention, the locally averaged voltage U_{AOLAVR} is non-sinusoidal and does not follow the reference voltage U_A as in the prior art. The line-to-line voltage U_L , the difference between any two of non-sinusoidal U_{AOLAVR} , U_{BOLAVR} and U_{COLAVR} , remains sinusoidal as long as the amplitudes of the input voltages U_A, U_B , and U_C , remain smaller than $+U_{TP}$ which is fulfilled if the amplitudes of U_A, U_B and U_C are smaller than $1.154 * U_{TP}$. The sinusoidal locally averaged line-to-line voltages provide, in a balanced three-phase load, sinusoidal locally averaged load phase voltages $U_{AO'LAVR}$, $U_{BO'LAVR}$ and $U_{CO'LAVR}$. The amplitude of the non-distorted line-to-line voltage is U_{DC} , causing the non-distorted locally averaged phase voltages $U_{AO'LAVR}$, $U_{BO'LAVR}$ and $U_{CO'LAVR}$ to have amplitudes $U_{DC}/\sqrt{3}$ which is 15.4% higher than $\frac{U_{dc}}{2}$. $\frac{U_{dc}}{2}$ is the amplitude of locally averaged load phase voltages ($U_{AO'LAVR} = U_{AOLAVR}$; $U_{BO'LAVR} = U_{BOLAVR}$; $U_{CO'LAVR} = U_{COLAVR}$) that can be achieved using triangle comparison methods without RMB 1. Thus the invention extends linearity because $U_{AO'LAVR}$ tracks U_A at a voltage U_A 15.4% higher than in the prior art.

Whereas Figs. 6, 7, and 8 represent the input/output characteristics where the modulation index m_A is .8, Figs. 9, 10, and 11 show the case where the modulation index m_A is 15.4% higher than 1, equal to 1.154. Figs. 2 and 3 are to Figs. 6, 7, and 8, respectively, as Figs. 4 and 5 are to Figs. 9, 10, and 11, respectively; for the former five figures m_A is less than 1, while for the latter five figures m_A is greater than 1. Despite the higher reference phase voltage U_A (where $m_A = 1.154$), the inverter operation remains linear. Fig. 9 shows that during sections "A", the locally averaged phase voltage $U_{AO'LAVR}$ continues to track the reference U_A . Graphs for sections "B" and "C" are similar, but lag "A" by 120° and 240° .

The invention may be implemented in hardware or software. Selection of maximum values of phase voltage references U_A, U_B and U_C ; U_{MAX} and $U_{BIAS} = U_{TP}$ provides continuous conduction of switches S1, S2 and S3 and continuous turnoff of complementary switches S1*, S2* and S3* during periods of time when corresponding voltage references are maximum. Selection of minimum values of references U_A, U_B and U_C ; U_{MIN} and $U_{BIAS} = -U_{TP}$ will provide continuous conduction of switches S1*, S2* and S3* and continuous turn off of switches S1, S2 and S3 during periods of time when corresponding voltage reference are minimum. The same results regarding extended linearity and reduced commutative losses hold for both cases. In addition, the bridge comprising the PWM 3 and the bridge 5 may be either for inversion, i.e. a constant voltage to alternating voltage transformation, or conversion, i.e. alternating voltage to constant voltage transformation. Fig. 1 presents an inverter circuit implementing the invention. If elements 70 are replaced by sinusoidal power voltage

sources U_D and U_E and U_F in series with inductors, a converter for implementing the invention is obtained as shown in Fig. 12. Whereas for the inverter circuit the AC voltage output is increased by 15.4%, for the converter with the source DC power output, the AC input voltage is increased over the prior art by the same amount.

Although the invention has been shown and described with respect to a best mode embodiment thereof, it should be understood by those skilled in the art that the foregoing and various other changes, omissions, and additions in the form and detail thereof may be made therein without departing from the scope of the invention.

Claims

1. A method of voltage conversion using a pulse-width-modulator and a bridge, said bridge including at least three legs, each including two complementary switches, comprising the steps:
 - providing a plurality of sinusoidal reference signals, displaced one from another by a phase angle, one associated with each leg;
 - detecting a maximum magnitude of said sinusoidal reference signals for providing a maximum reference signal;
 - subtracting said maximum reference signal from a signal of constant magnitude equal to the amplitude of a triangle carrier signal from said pulse width modulator, for providing a difference signal;
 - adding said difference signal to said sinusoidal reference signals for providing a plurality of augmented reference signals, one associated with each leg, to said pulse-width-modulator.
2. The method of claim 1, wherein said bridge is used for conversion from alternating voltage to constant voltage.
3. The method of claim 1, wherein said bridge is used for conversion from constant voltage to alternating voltage.
4. A voltage conversion bridge including a pulse-width-modulator (PWM) and a bridge operatively connected to said PWM, said bridge including at least three legs, each including two complementary switches, comprising:
 - means for providing a plurality of sinusoidal reference signals, displaced one from another by a phase angle, one associated with each leg;
 - detecting means for detecting a maximum magnitude of said sinusoidal reference signals for providing a maximum reference signal;
 - subtracting means for subtracting said

maximum reference signal from a signal of constant magnitude equal to the amplitude of a triangle carrier signal from said pulse width modulator, for providing a difference signal;

a summer for adding said difference signal to said sinusoidal reference signals for providing a plurality of augmented reference signals, one associated with each leg, to said pulse-width-modulator.

5

10

5. The voltage conversion bridge of claim 4, wherein said bridge is used for conversion from alternating voltage to constant voltage.

6. The voltage conversion bridge apparatus of claim 4, wherein said bridge is used for conversion from constant voltage to alternating voltage.

15

20

25

30

35

40

45

50

55

8

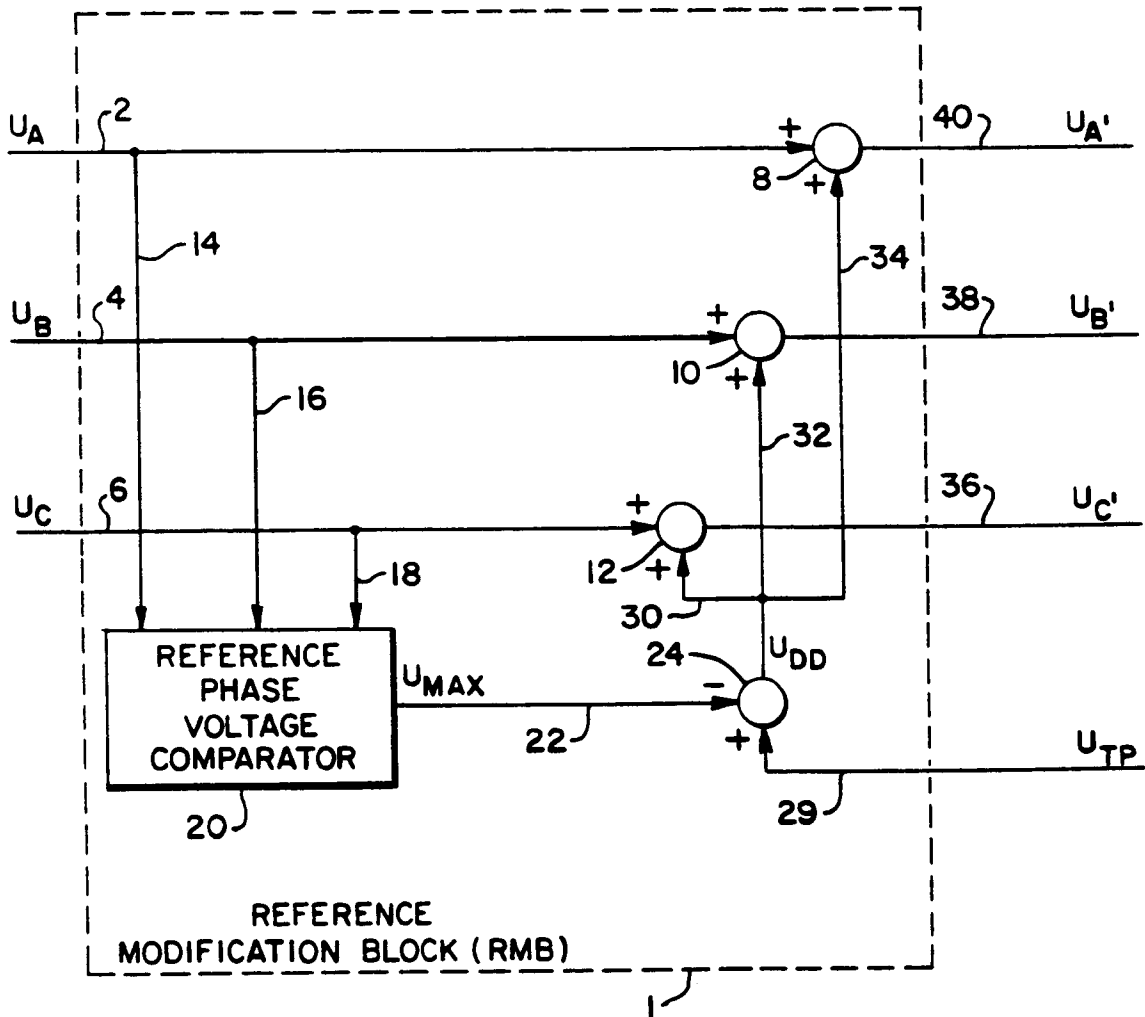

FIG. 1A

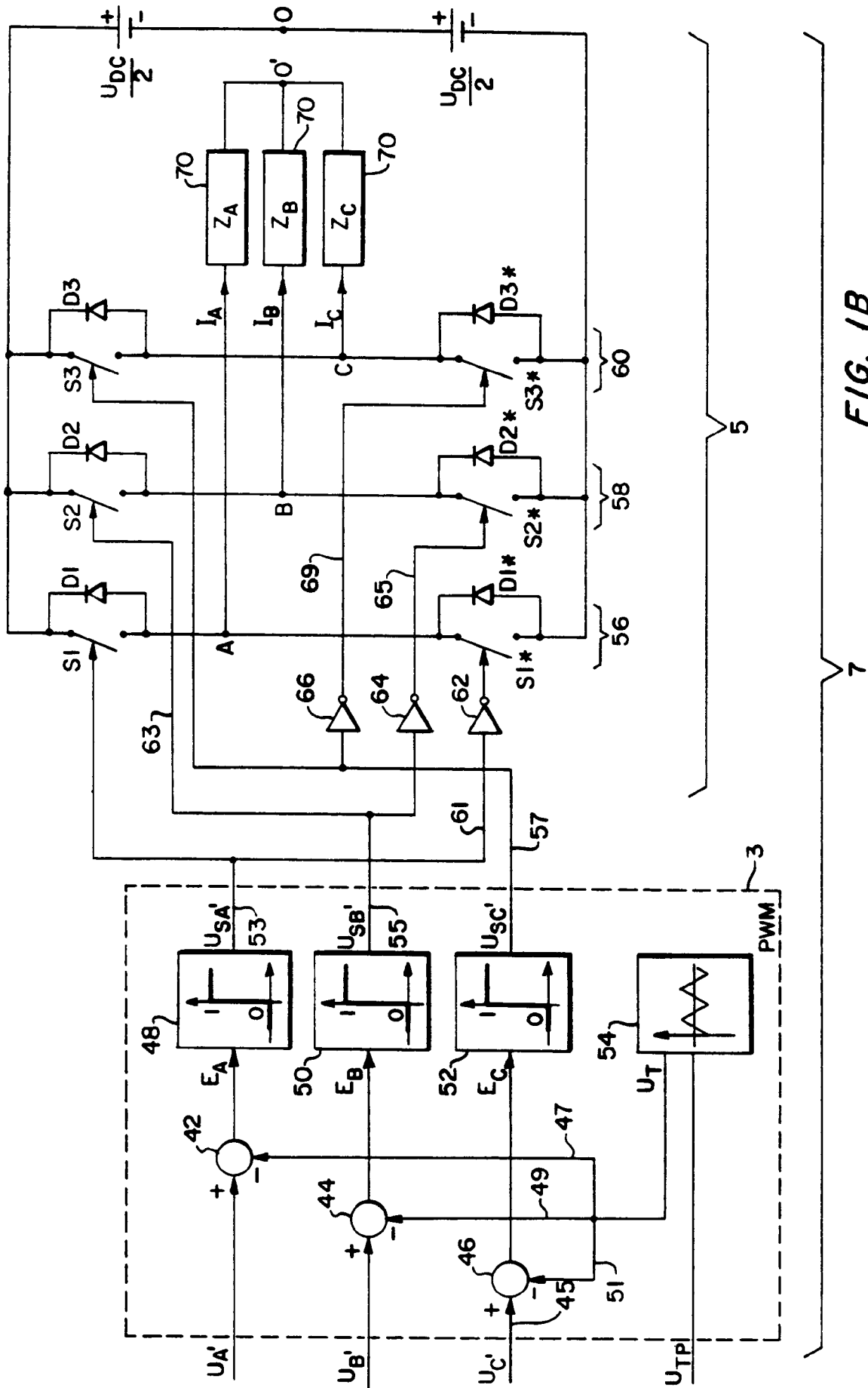

FIG. 1B

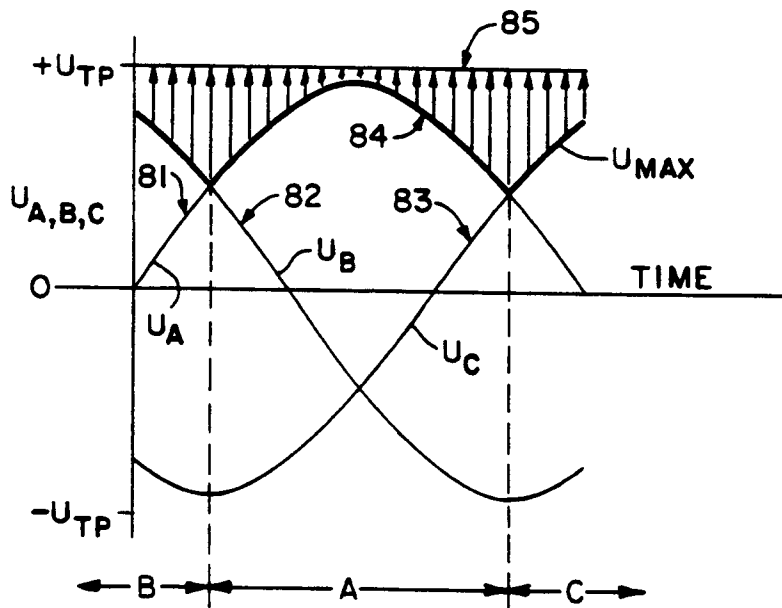

FIG. 2

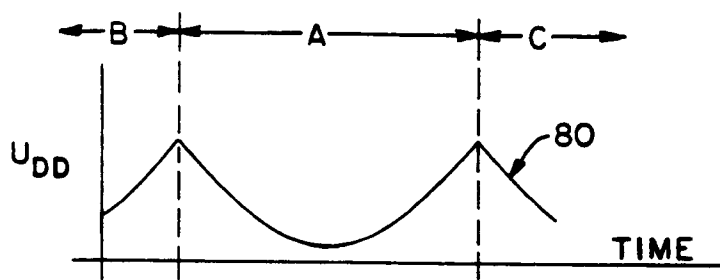

FIG. 3

FIG. 4

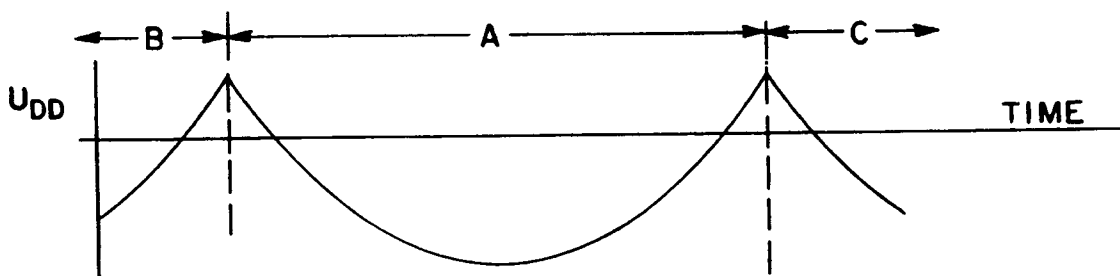
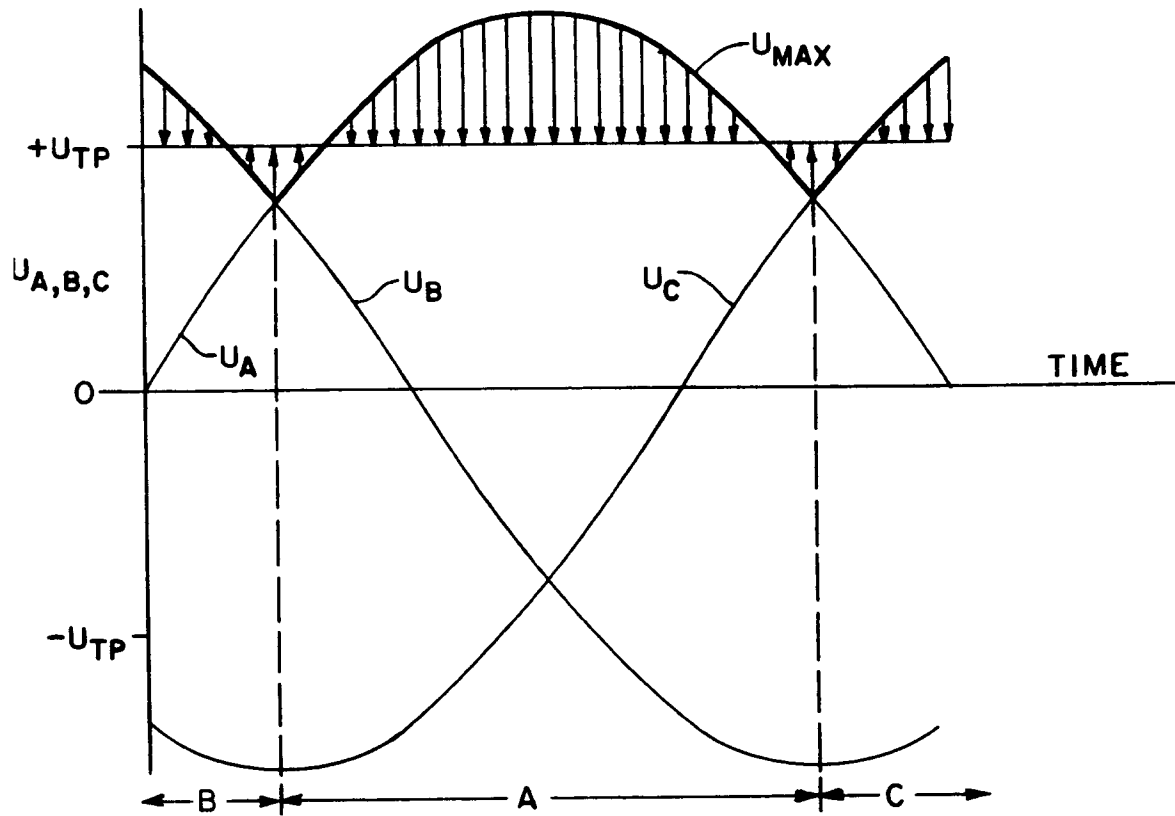

FIG. 5



FIG. 6

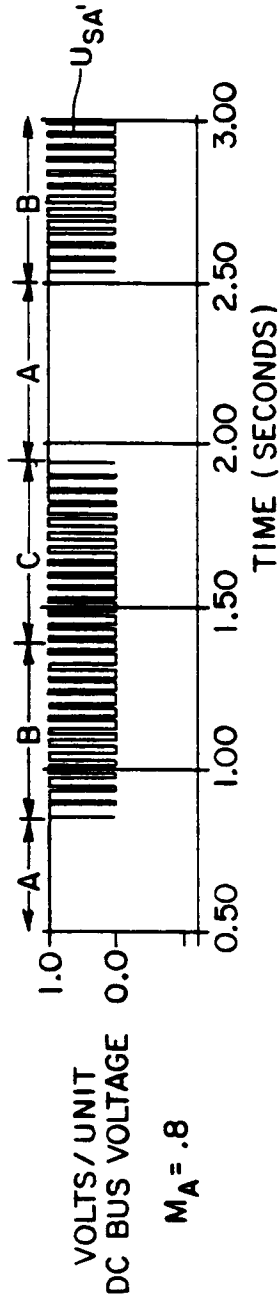

FIG. 7

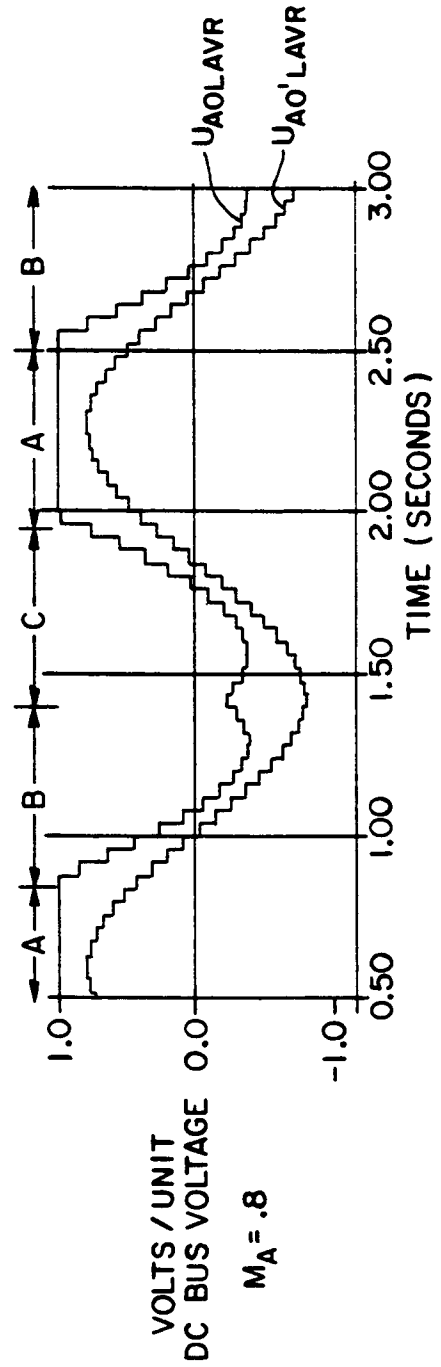
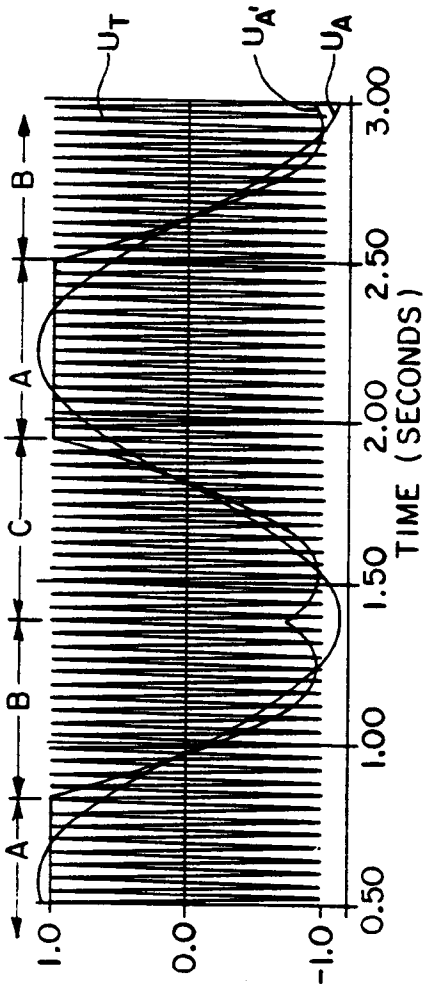
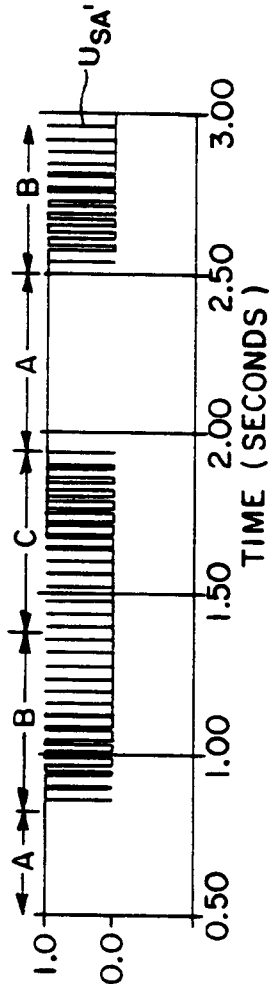

FIG. 8



VOLTS / UNIT
DC BUS VOLTAGE
 $M_A = 1.154$

FIG. 9



VOLTS / UNIT
DC BUS VOLTAGE
 $M_A = 1.154$

FIG. 10

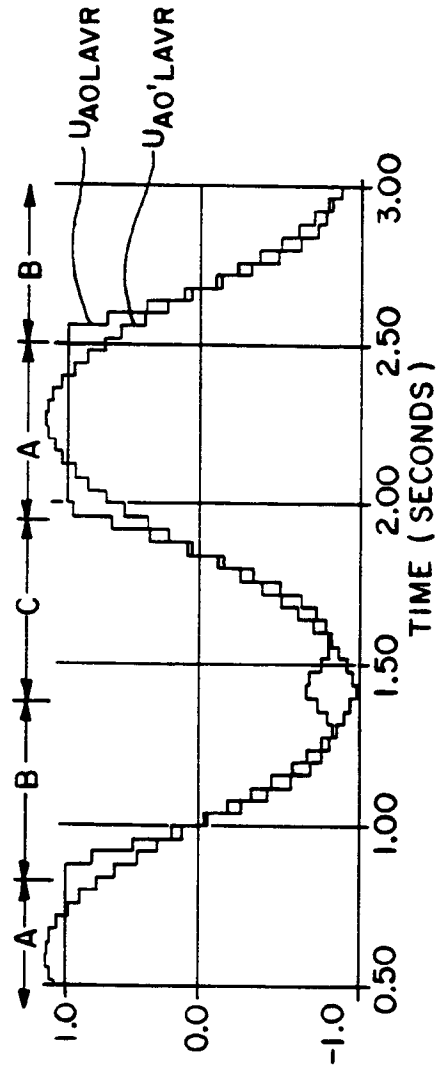

VOLTS / UNIT
DC BUS VOLTAGE
 $M_A = 1.154$

FIG. 11

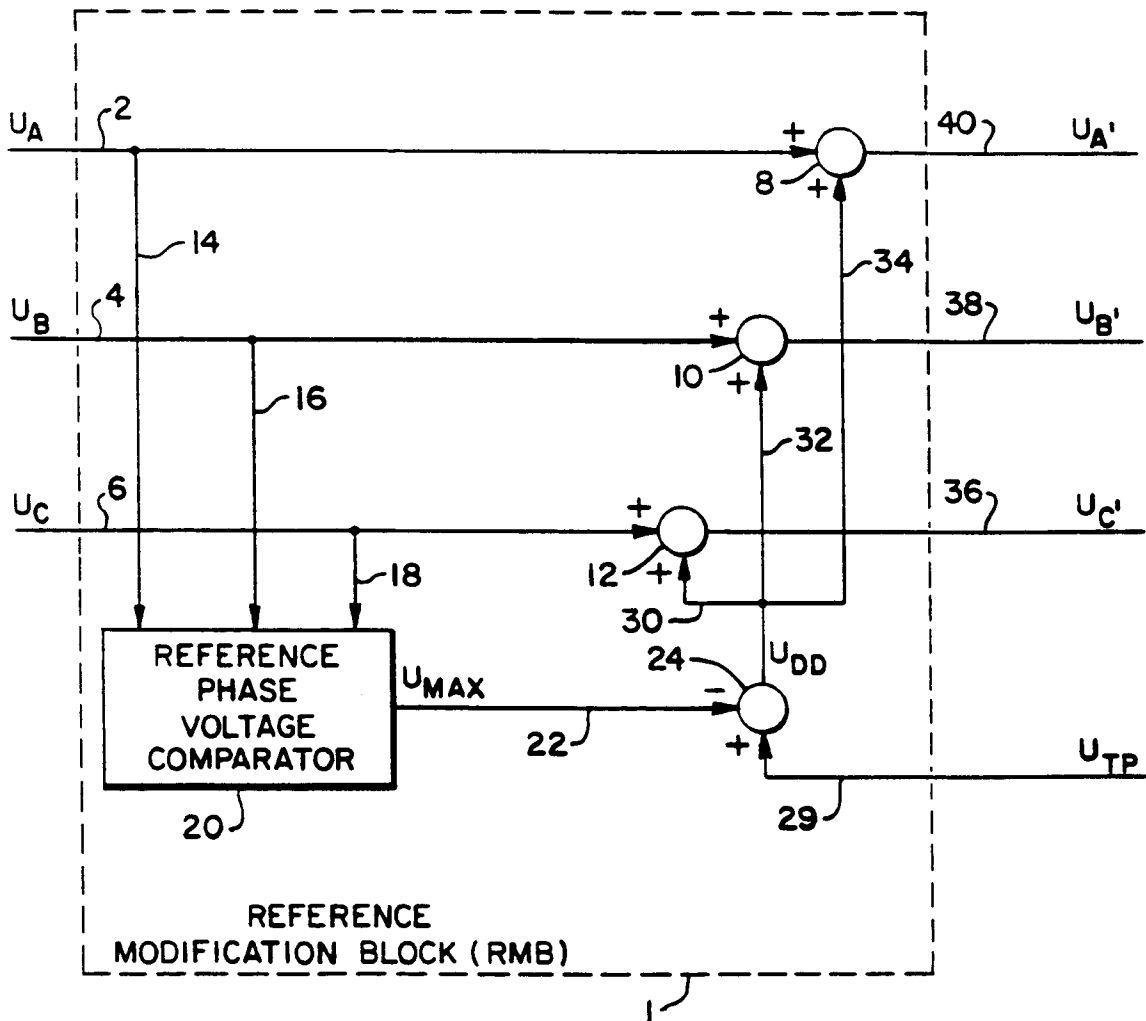

FIG. 12A

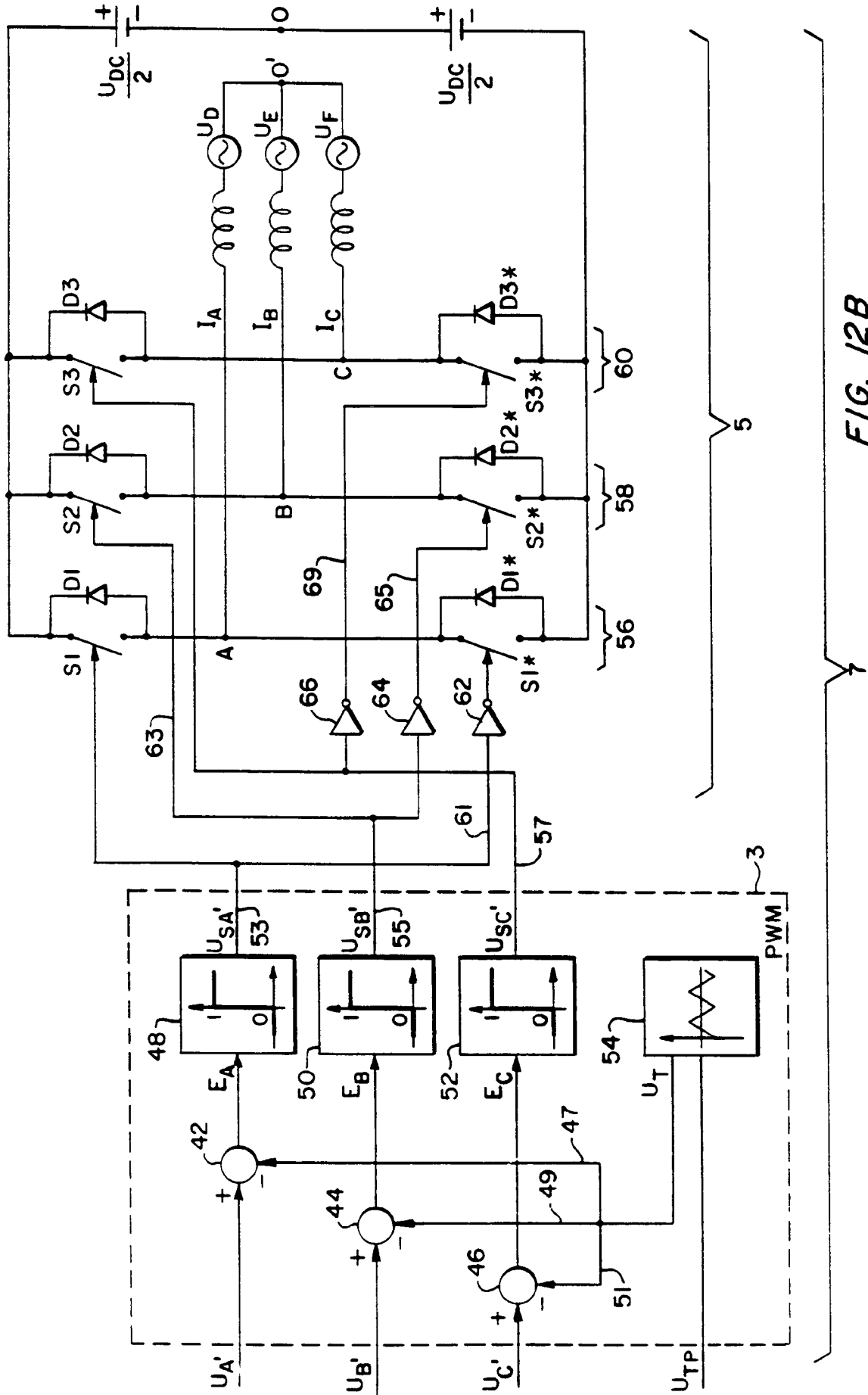

FIG. 12B



European Patent
Office

EUROPEAN SEARCH REPORT

Application Number

DOCUMENTS CONSIDERED TO BE RELEVANT			EP 92308049.3
Category	Citation of document with indication, where appropriate, of relevant passages	Relevant to claim	CLASSIFICATION OF THE APPLICATION (Int. Cl.5)
D, A	IEEE - IAS, Conference Record of the 1988 IEEE Industry Applications Society Annual Meeting 23rd, 1988, MELESANI, TENTI, GAIO, PIOVAN "Improved Current Control Technique of VSI PWM Inverters with Constant Modulation Frequency and Extended Voltage Range", pages 724,725 * Page 724, column 1, line 1 - column 2, line 25; page 725, column 1, lines 14-55; fig. 3 *	1, 3, 4, 6	H 02 M 7/5395 H 02 M 7/797 H 03 K 7/08
A	EP - A - 0 356 547 (SIEMENS AG) * Page 6, column 10, lines 4-47; page 10, column 18, line 22 - page 11, column 19, line 16; fig. 8,17; claims 1,3,4 *	1, 3, 4, 6	TECHNICAL FIELDS SEARCHED (Int. Cl.5) H 02 M H 03 K
A	GB - A - 2 222 328 (KABUSHIKI KAISHA TOSHIBA) * Page 4, line 6 - page 5, line 19; fig. 1; claims 1,2,3,4 *	1, 3, 4, 6	
A	US - A - 4 951 187 (STEMMLER) * Column 3, lines 5-42; column 7, lines 11-49; fig. 1; claims 1,3 *	1-6	
A	US - A - 4 994 951 (IWASA et al.) * Column 2, lines 9-21; column 3, lines 27-63;	1, 3, 4, 6	
The present search report has been drawn up for all claims			
Place of search VIENNA		Date of completion of the search 04-12-1992	Examiner MEHLMAUER
CATEGORY OF CITED DOCUMENTS X : particularly relevant if taken alone Y : particularly relevant if combined with another document of the same category A : technological background O : non-written disclosure P : intermediate document		T : theory or principle underlying the invention E : earlier patent document, but published on, or after the filing date D : document cited in the application L : document cited for other reasons & : member of the same patent family, corresponding document	

EPO FORM 1503 03.82 (P0401)



European Patent
Office

EUROPEAN SEARCH REPORT

Application Number

-2-

EP 92308049.3

DOCUMENTS CONSIDERED TO BE RELEVANT		
Category	Citation of document with indication, where appropriate, of relevant passages	Relevant to claim
	fig. 1; claims 1,2 * -----	
		CLASSIFICATION OF THE APPLICATION (Int. Cl.5)
		TECHNICAL FIELDS SEARCHED (Int. Cl.5)
The present search report has been drawn up for all claims		
Place of search VIENNA	Date of completion of the search 04-12-1992	Examiner MEHLMAUER
<p>CATEGORY OF CITED DOCUMENTS</p> <p>X : particularly relevant if taken alone Y : particularly relevant if combined with another document of the same category A : technological background O : non-written disclosure P : intermediate document</p> <p>T : theory or principle underlying the invention E : earlier patent document, but published on, or after the filing date D : document cited in the application L : document cited for other reasons</p> <p>..... & : member of the same patent family, corresponding document</p>		

EPO FORM 1503 03.82 (P0401)