

(19)



Europäisches Patentamt
European Patent Office
Office européen des brevets



(11)

EP 0 534 233 B1

(12)

EUROPEAN PATENT SPECIFICATION

(45) Date of publication and mention
of the grant of the patent:
14.08.1996 Bulletin 1996/33

(51) Int Cl.⁶: **D03D 47/20, D03D 47/18**

(21) Application number: **92115444.9**

(22) Date of filing: **09.09.1992**

(54) **Pair of weft carrying and drawing grippers for shuttleless looms, with weft transport on a slanting and, respectively, vertical plane**

Bringergreifer und Nehmergreifer für schützenlose Webmaschinen, mit Fadentransport in schräger beziehungsweise vertikaler Ebene

Griffe porteuse et griffe tireuse pour les métiers à tisser sans navette, avec transport de fils dans un plan incliné, respectivement vertical

(84) Designated Contracting States:
BE CH DE ES FR IT LI

(72) Inventor: **Viscardi, Ettore**
I-24027 Nembro (Bergamo) (IT)

(30) Priority: **11.09.1991 IT MI912405**

(74) Representative: **Faggioni, Marco, Dr. Ing. et al**
c/o Fumero Studio Consulenza Brevetti
Franz-Joseph-Strasse 38
80801 München (DE)

(43) Date of publication of application:
31.03.1993 Bulletin 1993/13

(73) Proprietor: **SOMET SOCIETA' MECCANICA**
TESSILE S.p.A.
I-24020 Colzate-Bergamo (IT)

(56) References cited:
EP-A- 0 248 486 **AT-A- 377 540**
CH-A- 502 461 **DE-A- 2 644 505**

EP 0 534 233 B1

Note: Within nine months from the publication of the mention of the grant of the European patent, any person may give notice to the European Patent Office of opposition to the European patent granted. Notice of opposition shall be filed in a written reasoned statement. It shall not be deemed to have been filed until the opposition fee has been paid. (Art. 99(1) European Patent Convention).

Description

The object of the present invention is a pair of weft carrying and drawing grippers for shuttleless looms. As known, grippers are those members in shuttleless looms, by means of which the single weft yarns are gripped at one end of the loom and conveyed to the opposite end thereof through the warp shed. The carrying gripper grips the weft yarn from a weft feeding device and conveys it to the centre of the shed. The drawing gripper receives the weft yarn from the carrying gripper, at the centre of the shed, and conveys it to the opposite end of the loom.

There are known to be many types of grippers apt to perform this function, which have undergone successive improvements, differing as far as even slight constructive details, but all meant to improve, on one hand, the working life of the grippers and, on the other hand, the weft yarn gripping and releasing function. In actual fact, one of the most delicate working steps in these types of looms is that of weft yarn exchange between the carrying and drawing gripper: during this step it could in fact happen that the weft yarn either gets damaged, or even broken, or that it fails to be caught by the drawing gripper, whereby weft exchange does not take place.

The present invention concerns, in particular, a loom of the type in which weft yarn transport and exchange take place on a vertical plane. To obtain this, the yarn clamping surfaces of the grippers are positioned according to a vertical plane, whereby the hook of the drawing gripper is positioned horizontally, instead of vertically as in more conventional technology. This arrangement is more frequently adopted in high-speed looms and provides - compared to previous technique - some advantages which include, in particular, a reduced height (dimension in a vertical direction) of the grippers and, consequently, a reduced friction due to rubbing between said grippers and the warp yarns, when the shed - in order to reduce the length of the cycle - is closed in advance in respect of the outlet of the grippers from the shed, thereby actually causing the rubbing of the warp yarns against said grippers. Furthermore, the structure of the drawing gripper is simplified, as it no longer requires the presence of the cover to protect the hook from the warp yarns, which often causes difficulties in transferring the weft yarn from the carrying gripper to the drawing gripper.

A carrying gripper like the one described above is for example the one disclosed in EP-A-248486, whose clamping zone has been conformed just to maintain the weft yarn in a vertical plane. Two different embodiments of the gripper are herein illustrated, respectively for yarns vertically and horizontally presented. In said two cases only the hook of a carrying gripper is shown, which is placed on an horizontal plane and respectively facing the reed and the side opposite to this latter. No advantage or inconvenience deriving from said two different orientations of the hook are pointed out.

Nevertheless, such an arrangement of the grippers is not free from drawbacks. In fact, to limit the risk that the hooking end, or other cutting edges of the drawing gripper, may accidentally cut the warp yarns - either during the final gripper outlet step, when the shed is closed in advance, or along the whole gripper path, in the event of the warp yarns having got caught into the shed - the drawing gripper is preferably positioned so as to have its hook facing the reed, namely the side opposite to the carrying gripper. Said arrangement, though limiting on one hand the aforementioned risks, causes on the other hand some inconveniences. In fact, to make sure that the hook of the drawing gripper correctly grips the weft yarn being conveyed by the carrying gripper, it is indispensable for the weft yarn tail clamped therein to be positioned on a vertical plane and, furthermore, to be perfectly tense. This causes a double inconvenience:

- on one hand, the dimensions of the carrying gripper have to be sufficiently large, especially in height, to allow housing therein a fairly long vertical stretch of the free weft yarn tail. But it has already been said how such a considerable height of the gripper involves inevitable and harmful rubbing thereof against the warp yarns;
- on the other hand, the carrying gripper should comprise means allowing to keep the weft yarn properly tensioned as it moves along the shed, and until weft yarn exchange has taken place.

The object of the present invention is therefore to propose a pair of weft carrying and drawing grippers of the general type described heretofore, which however eliminate the above drawbacks, while always guaranteeing a perfect weft yarn exchange at the centre of the shed.

In particular, an object of the present invention is to supply a pair of weft carrying and drawing grippers of reduced height, so as to notably lessen the rubbing of the gripper onto the warp yarns during the anticipated closing of the shed.

A further object of the present invention is to supply a pair of weft carrying and drawing grippers, wherein weft exchange takes place in reliable conditions even if the weft yarn tail carried by the carrying gripper is not perfectly tense.

According to the present invention, these and other objects are reached with a pair of weft carrying and drawing grippers for shuttleless looms - of the type in which the carrying gripper has a free space to house the head of the drawing gripper and weft yarn clamping means apt to hold the weft yarn tail through said space, and in which the drawing gripper has a horizontally positioned hook facing the carrying gripper, that is, the side opposite to the reed and a weft yarn clamping zone lying on a vertical plane - characterized in that the clamping means of the carrying gripper are apt to hold the weft yarn tail inside said free space along a slanting plane,

and said drawing gripper also comprises two bulging ribs, projecting upwards and respectively downwards from its head.

Further characteristics and advantages of the pair of weft carrying and drawing grippers according to the present invention will anyhow be more evident from the following detailed description of a preferred embodiment thereof, given by way of example and illustrated on the accompanying drawings, in which:

Fig. 1 is a simplified perspective view of the central part of a loom, with the pair of grippers according to the invention close to the point of weft yarn exchange, before the same takes place;

Fig. 2 is a lateral view of the drawing gripper according to the invention, in the direction of arrow F in fig. 1;

fig. 3 is a diagrammatic sectional view of the loom, along the line III-III of fig. 1, wherein - for clearness - the carrying gripper has been removed; and

Fig. 4 is a cross section view of the pair of grippers according to the present invention, in a position of weft yarn exchange.

As shown in fig. 1, the carrying gripper 1 and the drawing gripper 2 move one towards the other along the path 3 formed next to the reed 4. The carrying gripper 1 carries the weft yarn T, the tail T' of which is held by suitable clamping means through a free space 1a (see fig. 4) of said gripper. At the moment of weft yarn exchange, the drawing gripper 2 moves into said free space, with its hook 9 beyond the weft yarn tail T' and, in its subsequent backward movement, it hooks said tail T' and draws it along therewith.

According to the conventional technique described in the introductory part, a wide free space is formed inside the carrying gripper and the weft yarn tail T' is tensioned along a vertical plane outwardly of said free space; the drawing gripper, which is meant to move into said free space, is provided with a horizontally positioned hook which faces the reed 4, namely the side opposite to the carrying gripper, so as to grip from the inside the tense weft yarn tail T'.

Viceversa, according to the present invention and as clearly shown in figs. 1 and 4, the drawing gripper hook 9 faces the inner part of the carrying gripper 1, and thus the side opposite to the reed 4.

Fig. 4 shows in fact the carrying gripper 1 with its free space 1a housing (as shown in dashed lines) the weft yarn tail T'. Upon weft yarn exchange, the drawing gripper 2 first penetrates into said space 1a and then moves out therefrom, drawing along said tail T' with the hooking end 9a (fig. 2) of its hook 9; the tail T' then positions itself according to the broken line shown in full in fig. 4.

As can be easily seen from the dashed lines in fig. 4, the tail T' is positioned - while being conveyed by the carrying gripper 1 - on a slanting plane forming an angle

of less than 45° in respect of the horizontal plane, whereas - while being conveyed by the drawing gripper - it takes up a substantially vertical position (or a position slightly inclined towards the above slanting plane) shown in full lines in the same fig. 4. It should of course be clear that, when referring - here and elsewhere in the present description - to horizontal and vertical planes, one means, more exactly, the plane coinciding with the sliding plane of the grippers, and the plane perpendicular thereto.

This slanting arrangement taken up by the weft tail T' inside the space 1a of the gripper 1 is possible only thanks to the fact that the drawing gripper hook faces the inside of said free space. In fact, to hook the weft yarn, it is sufficient for the front end 9C of the gripper head to be positioned to the right of (or further down than) the weft tail T', and for the hooking end 9a of the gripper hook to be instead positioned to the left of (or further up than) said weft tail T' (fig. 2).

The above arrangement allows - according to an advantageous aspect of the present invention and as clearly shown on the drawings - to construct the carrying gripper of considerably reduced height, as compared to the grippers of known technique. Furthermore, the slanting arrangement of the weft tail T' allows said weft tail - in spite of the modest height of the gripper - to be sufficiently long to have an elasticity such that it can be overtaken without damages by the drawing gripper, as this latter penetrates into the carrying gripper.

The configuration of the drawing gripper with the hook facing the carrying gripper, could nevertheless cause the inconvenience - which is besides also the reason why this solution has never been adopted in known technique - of easily cutting off the warp yarns which bear onto the gripper during closing of the shed (as the yarns F1 and F2 drawn in thick lines in fig. 3), or else the yarns which get caught into the shed (i.e. non-separated yarns, as the yarns F3 and F4 drawn by dashed lines in fig. 3), due to the cutting action produced by sliding, either of the guiding edges 7 and 8 of the slidable wedge of the gripper, or of the hooking end 9a of the hook 9 (figs. 2 and 4).

This possible inconvenience is however overcome due to the fact that - always according to the invention and as shown in the drawings - the gripper 2 also comprises, in correspondence of the hook 9, two bulging ribs 5 and 6 projecting upwards and respectively downwards. In particular, the bulging rib 5 is positioned along the centre of the drawing gripper head and slightly backward in respect of its front end, while the bulging rib 6 is positioned along the side of the drawing gripper head closest to the loom reed, just below its front end. Such ribs are actually meant to spread apart the warp yarns which bear onto the gripper body during closing of the shed - as clearly shown in fig. 3 - so as to keep them spaced from the cutting edges of the gripper and hook, and prevent them from possibly being cut off.

A further advantage of the slanting arrangement of

the weft yarn tail T', held in the carrying gripper according to the invention, lies in the fact that it allows to weave also with a slightly braked weft yarn, thereby reducing friction on the weft and the need for devices apt to control and keep a perfect tension thereof. In fact, even if the weft tail T' should slightly loosen and follow a non-rectilinear path, the height of the hooking end 9a of the hook 9 - which is at a high level in respect of the gripper sliding plane - and the particular shape of its profile 9b, forwardly inclined towards the gripper head, determine a reliable hooking action in any condition of weft yarn tension.

From the previous description it is clearly evident how the pair of grippers according to the present invention has fully reached the intended objects. The grippers described and claimed herein are in fact of reduced height and therefore apt to strongly reduce rubbing against the warp yarns, and furthermore, the configuration of the drawing gripper is such as to prevent accidental cutting of the warp yarns during closing of the shed, or of the yarns which may have caught into the shed, and to reliably hook the weft yarn even when the same is not perfectly tense into the carrying gripper.

Claims

1. Pair of weft transport grippers for shuttleless looms - of the type in which the carrying gripper (1) has a free space (1a) to house the head of the drawing gripper (2) and weft yarn clamping means apt to hold the weft yarn tail (T') through said space, and in which the drawing gripper (2) has a horizontally positioned hook (9) facing the carrying gripper (1), that is, the side opposite to the reed (4) and a weft yarn clamping zone lying on a vertical plane - characterized in that the clamping means of the carrying gripper (1) are apt to hold the weft yarn tail (T') inside said free space along a slanting plane, and said drawing gripper (2) also comprises two bulging ribs (5, 6), projecting upwards and respectively downwards from its head.
2. Pair of weft grippers as in claim 1), wherein said slanting plane of the weft yarn tail (T') forms an angle of less than 45° in respect of the horizontal plane.
3. Pair of weft grippers as in claim 1), wherein- said upwardly bulging rib (5) extends along the centre of the drawing gripper head, slightly backward in respect of its front end (9c).
4. Pair of weft grippers as in claim 1), wherein said downwardly bulging rib (6) extends along the side of the drawing gripper head closest to the loom reed (4), just below its front end (9c).

5. Pair of weft grippers as in claim 1), wherein the hooking end (9a) on the rear part of the drawing gripper hook (9) is positioned high in respect of the gripper sliding plane.

6. Pair of weft grippers as in claim 5), wherein said hooking end (9a) is connected to the hook base through a forwardly inclined surface (9b).

Patentansprüche

1. Ein Paar von Schußfadentransportgreifern für schützenlose Webmaschinen - von der Art, bei dem der Traggreifer (1) einen freien Raum (1a) hat, um den Kopf des Zuggreifers (2) und Schußfadenklemmmittel, die dazu eingerichtet sind, das Ende (T') des Schußfadens durch den Raum zu halten, aufzunehmen, und bei dem der Zuggreifer (2) einen horizontal positionierten Haken (9), der zu dem Traggreifer (1), also der dem Blatt (4) gegenüberliegenden Seite weist, und eine Schußfadenklemmzone, die auf einer vertikalen Ebene liegt, hat -, dadurch gekennzeichnet, daß das Klemmmittel des Traggreifers (1) dazu eingerichtet sind, das Ende des Schußfadens (T') im Inneren des freien Raumes entlang einer schräg verlaufenden Ebene zu halten, und der Zuggreifer (2) weiter zwei ausbuchtende Rippen (5, 6) aufweist, die von dem Kopf nach oben bzw. nach unten vorragen.
2. Ein Paar von Schußfadengreifern nach Anspruch 1, wobei die schräg verlaufende Ebene des Endes des Schußfadens (T') einen Winkel von weniger als 45° bezüglich der horizontalen Ebene bildet.
3. Ein Paar von Schußfadengreifern nach Anspruch 1, wobei die sich nach oben ausbuchtende Rippe (5) sich entlang der Mitte des Zuggreiferkopfs leicht nach hinten bezüglich dessen vorderen Endes (9c) erstreckt.
4. Ein Paar von Schußfadengreifern nach Anspruch 1, wobei die sich nach unten ausbuchtende Rippe (6) sich entlang der Seite des Kopfs des Zuggreifers erstreckt, die dem Blatt (4) der Webmaschine am nächsten ist, gerade unterhalb seines vorderen Endes (9c).
5. Ein Paar von Schußfadengreifern nach Anspruch 1, wobei das hakenförmige Ende (9a) auf dem rückwärtigen Teil des Zuggreiferhakens (9) bezüglich der Gleitebene des Greifers hoch positioniert ist.
6. Ein Paar von Schußfadengreifern nach Anspruch 5, wobei das hakenförmige Ende (9a) mit der Basis des Hakens über eine nach vorne geneigte Fläche (9b) verbunden ist.

Revendications

1. Paire de griffes de transport de trame pour métiers à tisser sans navette - du type dans lequel la griffe porteuse (1) comporte un espace libre (1a) pour loger la tête de la griffe tireuse (2) et un moyen de serrage de fil de trame adapté à tenir la queue (T') du fil de trame dans ledit espace, et dans lequel la griffe tireuse (2) comporte un crochet positionné horizontalement (9) qui donne sur la griffe porteuse (1), c'est-à-dire sur le côté à l'opposé du peigne (4) et une zone de serrage de fil de trame se situant sur un plan vertical - caractérisée en ce que le moyen de serrage de la griffe porteuse (1) est adapté à tenir la queue (T') du fil de trame dans ledit espace libre le long d'un plan incliné, et ladite griffe tireuse (2) comprend également deux nervures renflées (5, 6) se projetant respectivement vers le haut et vers le bas de sa tête.

5
10
15
20
2. Paire de griffes de trame selon la revendication 1, dans laquelle ledit plan incliné de la queue (T') du fil de trame forme un angle inférieur à 45° relativement au plan horizontal.

25
3. Paire de griffes de trame selon la revendication 1, dans laquelle ladite nervure renflée vers le haut (5) s'étend le long du centre de la tête de la griffe tireuse, légèrement en arrière par rapport à son extrémité avant (9c).

30
4. Paire de griffes de trame selon la revendication 1, dans laquelle ladite nervure renflée vers le bas (6) s'étend le long du côté de la tête de la griffe tireuse le plus près du peigne (4) du métier, juste sous son extrémité avant (9c).

35
5. Paire de griffes de trame selon la revendication 1, dans laquelle l'extrémité d'accrochage (9a) sur la partie arrière du crochet (9) de la griffe tireuse est positionnée à un niveau élevé relativement au plan de glissement des griffes.

40
6. Paire de griffes de trame selon la revendication 5, dans laquelle ladite extrémité d'accrochage (9a) est reliée à la base du crochet via une surface inclinée vers l'avant (9b).

45
50
55

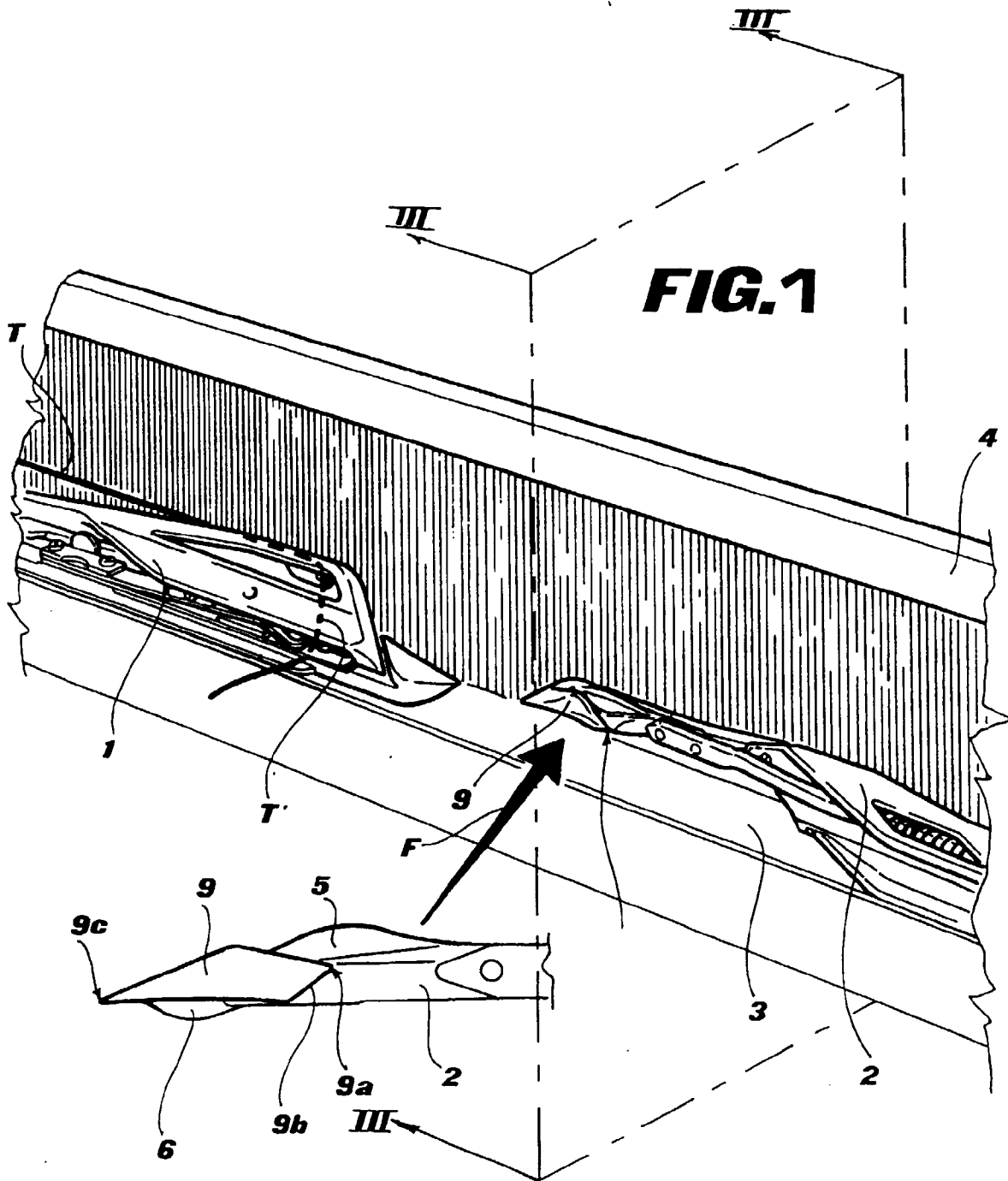

FIG. 2

FIG. 3

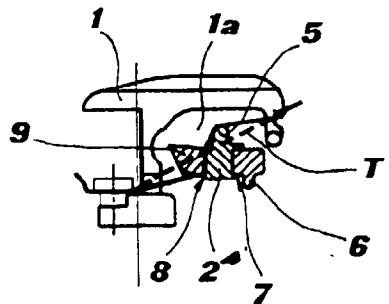
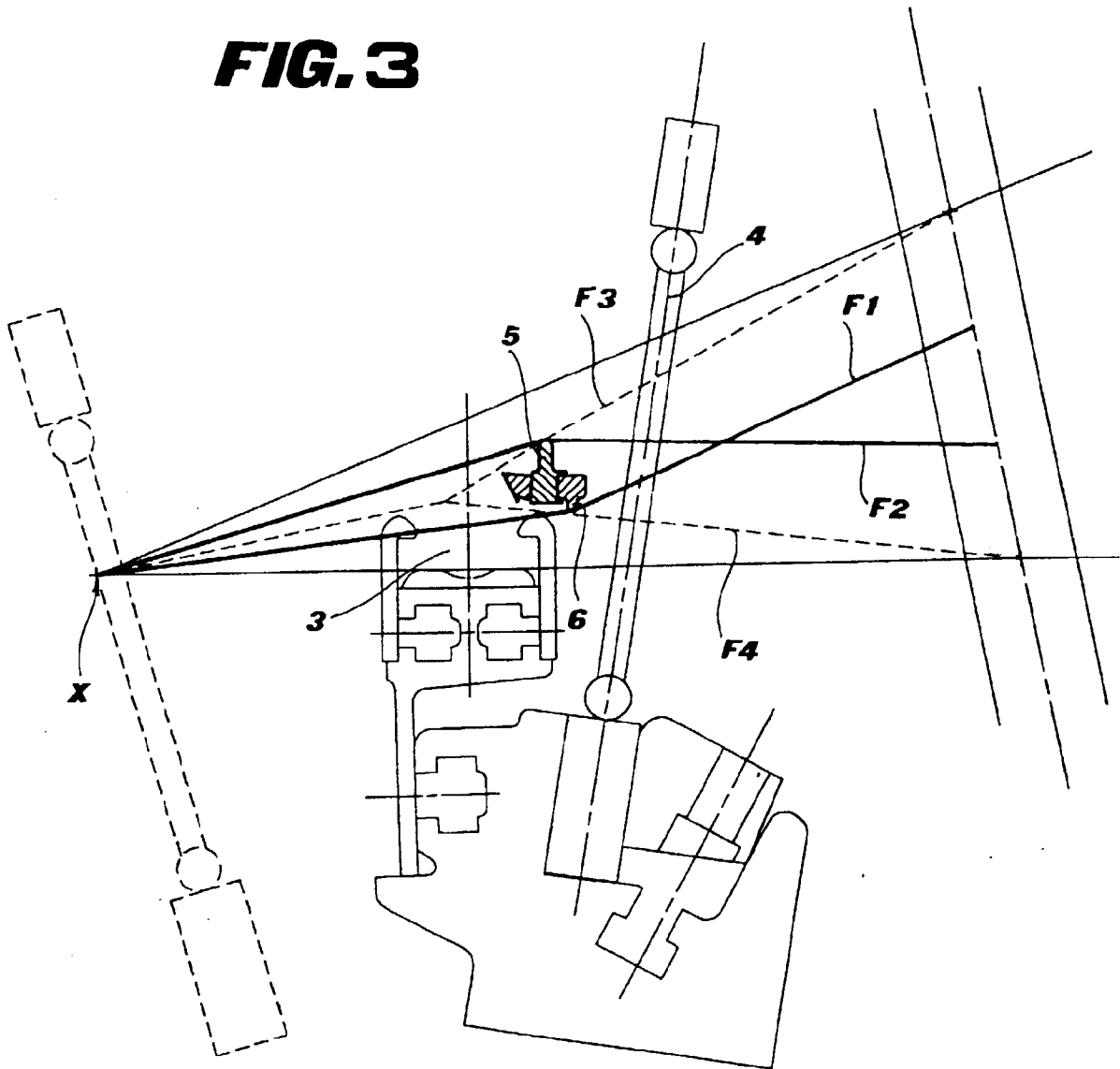

FIG. 4