



Europäisches Patentamt
European Patent Office
Office européen des brevets



Publication number: **0 536 460 A1**

EUROPEAN PATENT APPLICATION

Application number: **91830419.7**

Int. Cl.⁵: **B67B 3/20**

Date of filing: **08.10.91**

Date of publication of application:
14.04.93 Bulletin 93/15

Applicant: **Lenzi, Mauro**
Via G. Paganino 2
I-56100 Pisa(IT)

Designated Contracting States:
DE ES FR GB IT

Inventor: **Lenzi, Mauro**
Via G. Paganino 2
I-56100 Pisa(IT)

Representative: **Massari, Marcello**
Studio M. Massari S.r.l. 23, Via Fontanella
Borghese
I-00186 Roma (IT)

Device for screwing to containers caps or plugs provided with outer knurling by a predetermined, constant driving torque.

A device for screwing to containers pre-threaded caps or plugs provided with outer knurling by a predetermined, constant driving torque, even of extremely limited amount, comprising a main body 1 which is made integral with the machine spindle and in which a "spline" shaft 4 rotating together with the main body is supported, said body being able to axially shift and being held in the advanced position by two springs; a "socket" 15 of very little mass supported by two bearings 9 and then "idle" with respect to the rotation of the spline shaft is provided at the opposite end of the motor shaft within said spline shaft, said socket being internally provided with a tothing steadily engaging the cap inserted therein; a set clutch system acting on the socket and connected to the spline shaft so as to rotate together with the latter, said clutch being formed of a magnetic friction 13,14 of very little mass so that, when the cap rotating along with the socket is completely screwed, the opposed resistance causes the friction to slide and the main body of the device together with the spline shaft can rotate while the socket with the cap stops after having provided a driving torque depending on the calibration of the clutch system.

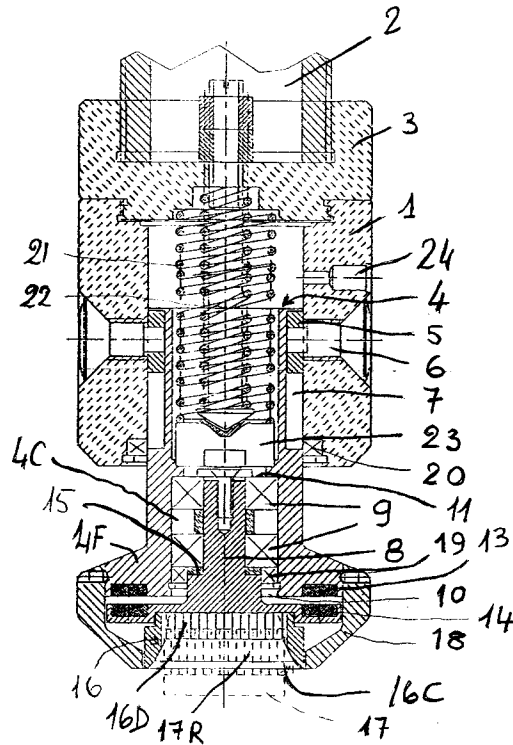

FIG. 1

EP 0 536 460 A1

A first subsidiary device intended to be used with particular caps or in case of hard screwing or very light driving torque provides for screwing but not tightening the cap without any limit to the screwing torque, while a set clutch seeks to provide for the final tightening.

Another device to be interposed between the screwing head and the spindle of the screwer allows the revolutions of the screwing head to be increased with regard to the spindle so that also cappers can be used designed for aluminum caps and not adapted to screw pre-threaded caps.

The present invention seeks to provide a solution to the problem of screwing and tightening pre-threaded caps or plugs to containers by an extremely simple and reliable device characterized by a very low, constant driving torque.

As known, screwing cappers are generally comprised of a collar support on which the container, e.g. a bottle, is standing with the cap to be screwed resting on its mouth and a motor shaft in line with the cap, which shaft can carry out two motions: a rotary motion and a reciprocal traverse motion covering the distance from the container to which the cap has to be screwed. The device of the invention, so-called also "screwing head", is placed at the end of the motor shaft of the cappers and provides for the screwing of the cap to the container and then for the tightening thereof. It is self evident that a right and constant torque wrench setting is very important both to assure the hermetic seal of the product and to allow the cap to be easily screwed out.

The device of the present invention provides by an extremely simple means a driving torque which is independent of the speed of rotation of the "screwing head" as the mass of the screwing members to be clamped to the cap when the latter is being tightened is reduced to a minimum so that the kinetic energy of such members would not be transmitted to the cap.

The device is now described with reference to the drawings.

The main section of the device in its easiest arrangement is shown in Fig. 1. Main body 1 of the device is connected to the motor shaft of spindle 2 through cover 3; spline shaft 4 is rotatably driven through tabs 5 and pins 6 by main body 1 and can be axially shifted with regard thereto according to the length of grooves 7. The operating portion of spline shaft 4 ends in a flange 4F and a central bell 4C. A socket-carrying axis 8 is provided within said bell and supported by bearings 9 so as to freely rotate with regard to spline shaft 4. Bearings 9 are held by plastic ring 10, while axis 8 is held by screw and washer 11.

Flange 4F carries a set of magnetic elements 13 in a sunburst arrangement facing a similar set of

magnetic elements 14, thus forming a magnetic "clutch", the torque of which can be varied by changing the height of the spacer 15.

Connected to socket-carrying axis 8 is the screwing socket 16 which is thus interchangeable. The interior of screwing socket 16 consists of a bell 16C to facilitate the introduction of the cap or plug 17 to be screwed, and a set of inner teeth disposed in the almost cylindrical seat 16D (see also Fig. 6) which are able to engage the outer knurling 17R of cap when the latter is introduced thereto. It is apparent that, if the cap to be screwed is manually changed, there is needed to also change the screwing socket to assure the compatibility between teeth 16D and knurling 17R.

Bell 18, which is made integral with flange 4F, has the function of protecting the interior of the screwing head from the liquids abounding in such operations besides an aesthetic function. Dust covers 19 and 20 have a similar protection function. Springs 21 e 22 placed between head 3 and cup 23 hold spline shaft 4 in its extended position. A grease nipple for the inner lubrication is designed by 24.

In operation, the "screwing head" rotates along with spindle 2 and approaches axially the container with cap 17 resting on the threaded mouth. The arrangement is such that cap 17 is snugly introduced into the "centering bell" 16C during the approaching motion of the screwing head to the container, and the cap is inserted into the toothed seat 16D up to the contact with the screwing socket, whereupon cap 17 pushed against screwing socket 16 causes spline shaft 4 to retract into main body 1 of the head and to press springs 21 and 22. The head remains for a while in such "advanced" position rotating about itself in the screwing direction of the cap. Thus cap 17 is screwed to the container and in such screwing motion it is shifted so that screwing socket 16 and spline shaft 4 under the action of springs 21 and 22 follow the shifting of cap 17.

At the end of the screwing of the cap the resisting moment increases quickly, and as soon as it exceeds the couple of the magnetic clutch, screwing socket 16 and axis 8 stop along with cap 17, while spline shaft 4 carries on rotating along with the "screwing head". After a certain time or a predetermined number of revolutions of spindle 2 the head is moved away from the screwing position to the container by an axial movement, spline shaft 4 carries on rotating until tabs 5 reach the end of grooves 7 and then spline shaft along with screwing socket 16 moves together with the head away from the cap which has been screwed to the container.

In Fig. 2 a very special screwing socket 16 which is a further development of the foregoing

socket is shown. It contains internally an accommodation cone 16E but no teeth 16D. Instead of the latter a cylindrical seat is provided with the function of promoting the straightening of cap 17 during the insertion into screwing socket 16.

In such a solution screwing socket 16 serves as guide for cap 17 and as seat for the toothed toroidal member 16TD which is formed of a ring the interior of which is shaped as a truncated cone and formed with teeth for engaging the cap. Such engagement is provided when cap 17 is pressed against the toothing of ring 16TD.

In Figs. 3 and 4 a plan view and an elevation view of the cycloidal gearing-up system are shown, respectively. It is interconnected between motor shaft 2 and the body of the head 1. In practice cover 3 of the above screwing head is removed and a gearing-up system is screwed thereto. Thus bell 32 is rigidly connected to motor shaft 2 and made integral with gear 33. The latter drives gear 34 through two pairs of planetary gears 35 and 36 supported by spider plate 37 which is held against rotation by rod 38. Thus central gear 34 which is integral with the body of head 1 rotates faster than gear 32 and motor shaft 2 in the same direction. The other members, bearings, pins and elastic rings have the evident function of holding the components and avoiding pebbles.

In Fig. 2 a complementary device adapted for particular caps, very light driving torques, and non homogeneously screwed caps is shown.

With reference to Figs. 5, 6 and 7 the same components as the preceding Fig. 1 are indicated at the same numerals increased by 100 so that the main body of head 1 of Fig. 1 is indicated at 101 a.s.o., the additional components having progressive numerals.

Such device provides an additional system with several oscillating arms 40 radially extending from screwing socket 116 and hinged to flange 104F by rotation pins 41. The closure and opening of such oscillating arms is controlled by ring 42 connected in turn to body 101 of the head through bell 43.

The closure is caused by the pressure of ring 42 against ball 44 which is exerted when the screwing socket causes spline shaft 104 to retract into the head, while the opening of the oscillating arms is caused by the same ring 42 pushing "lever" 45 of each arm when spline shaft 104 returns to its resting extended position.

Provided on one or more oscillating arms is a tooth 46 "penetrating" room 47 formed in the screwing socket 116 when the arms are in the "closed" position. Such position is shown in Figs. 6 and 7 wherein in the former also the inner teeth of the screwed cap are shown. When arms 40 are in the "opened" position teeth 46 are completely disengaged from rooms 47 as shown in Fig. 5.

Therefore, when the arms are in a closed position screwing socket 116 is rotated by teeth 46 which in turn are made integral with the head and then subjected to a non-limited screwing couple.

When teeth 46 pass through room 47 screwing socket is rotated only by the set clutch.

The arrangement of the system and the relative position of the head with respect to the container (e.g. a bottle) in the screwing position is such that before reaching the end of the screwing of the cap the oscillating arms 40 are being opened and teeth 46 are disengaged from rooms 47. It is now evident that the set clutch can brake by a very low friction amounts.

In Fig. 6 a tooth 48 is shown which can engage an oscillating arm 40 and protects the seal of the cap from injuries during the screwing. The screwing position is shown in Fig. 7. The funnel bell 49 so-called "centering member" has the function of conveying cap 117 into socket 116, is provided with as many rooms as the oscillating arms 40, and is rigidly connected to spline shaft 104 by screws 51. Room 104C in which journalling bearings 108 are housed is now separated from spline shaft 108 by construction reasons but it is rigidly connected thereto by screws 50.

Claims

1. A device for screwing to containers threaded caps or plugs provided with outer knurling by a predetermined, constant driving torque including in combination: a main body connected to the motor shaft, a spline shaft sliding lengthwise within said main body and rotatably driven by the latter by means of a pin and ball system limiting also the sliding stroke, and carrying at the lower end a bell flange inside which an idle socket provided with a set of teeth engaging firmly the cap inserted therein is housed, a clutch member acting between said spline shaft and said socket so as to rotate the latter with a maximum couple predetermined by the calibration of said clutch member.
2. The device of claim 1, wherein said clutch member is formed of one or more balls sliding in corresponding radial holes formed in said bell flange, each of them being pressed against said socket by a spring provided with adjusting screw.
3. The device of claim 2, wherein said balls are engaged into V-shaped grooves formed on the outer surface of said socket.

4. The device of claim 1, wherein said clutch member is engaged to and disengaged from said spline shaft which is axially shifted by the pressure of said cap within said socket.

5

5. The device of claim 4, wherein said clutch member is formed of an assembly of one or more oscillating arms hinged at the upper side to said bell, each oscillating arm carrying internally at least a ball housed in a hole and biased by a spring provided with adjusting screw, each ball being located outside said socket when the relative arm is in its opened position and inside said V-shaped grooves when said arm is in its closed position.

10

15

20

25

30

35

40

45

50

55

4

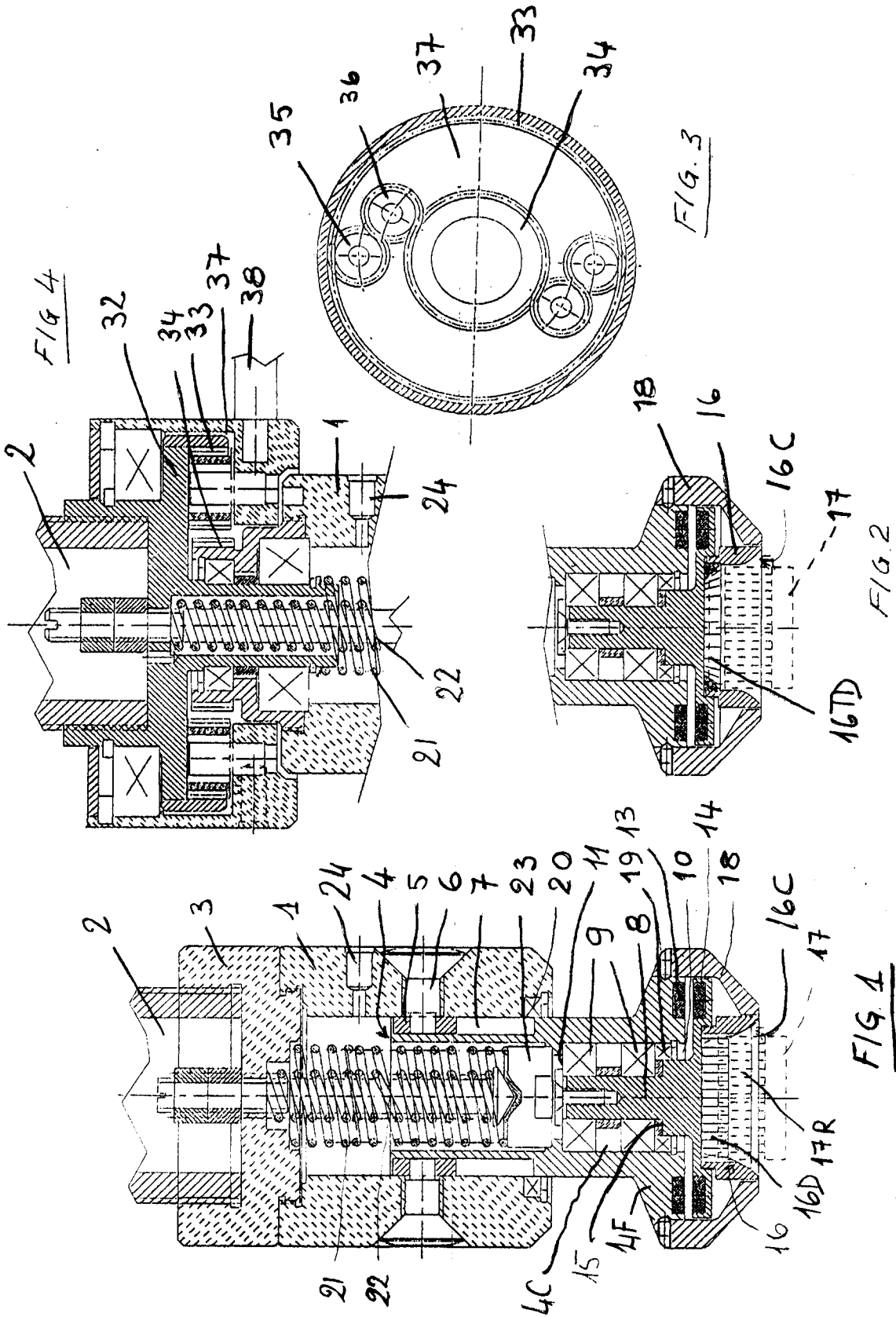

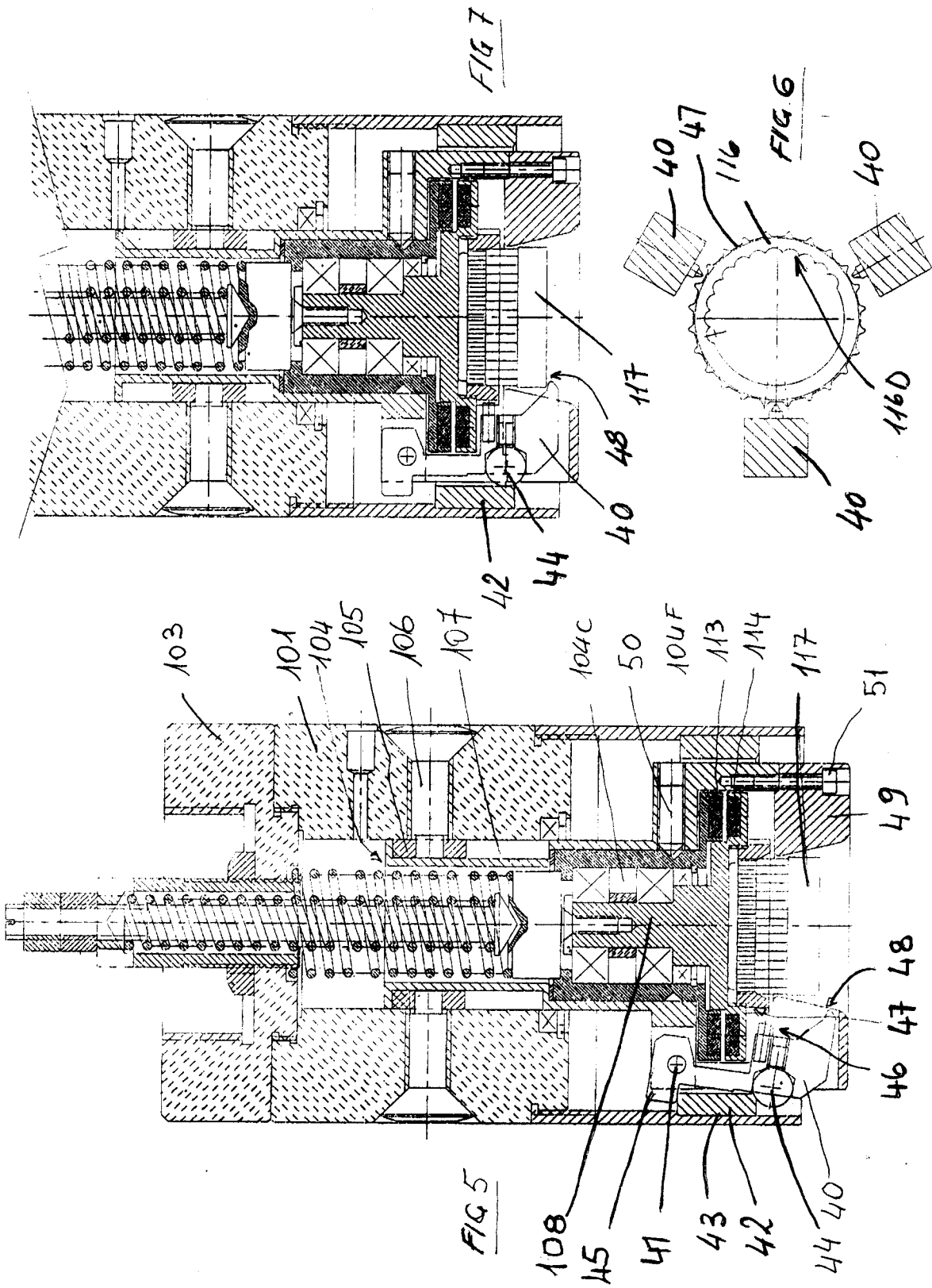



European Patent
Office

PARTIAL EUROPEAN SEARCH REPORT
which under Rule 45 of the European Patent Convention
shall be considered, for the purposes of subsequent
proceedings, as the European search report

Application Number

EP 91 83 0419

DOCUMENTS CONSIDERED TO BE RELEVANT			
Category	Citation of document with indication, where appropriate, of relevant passages	Relevant to claim	CLASSIFICATION OF THE APPLICATION (Int. Cl.5)
X	WO-A-8 602 917 (WIEDMER) * Abstract; figure *	1	B 67 B 3/20
X	GB-A-2 111 964 (OWENS-ILLINOIS INC.) * Page 2, lines 80-106; figure 1 *	1	
X	GB-A- 948 351 (METAL CLOSURES LTD) * Page 2, lines 103-110; figure 1 *	1	
X	FR-A-2 166 796 (FURSILICH HOHENZOLLERNSCHE HUTTENVERWALTUNG LAUCHERTHAL) * Page 6, line 36 - page 7, line 9; figure *	1	
A	DE-A-3 912 324 (ALCOA DEUTSCHLAND GmbH)		
			TECHNICAL FIELDS SEARCHED (Int. Cl.5)
			B 67 B
INCOMPLETE SEARCH			
<p>The Search Division considers that the present European patent application does not comply with the provisions of the European Patent Convention to such an extent that it is not possible to carry out a meaningful search into the state of the art on the basis of some of the claims</p> <p>Claims searched completely : 1 Claims searched incompletely : Claims not searched : 2-5</p> <p>Reason for the limitation of the search:</p> <p>Not searched claims are not supported by the description (Art. 84 EPC)</p>			
Place of search		Date of completion of the search	Examiner
THE HAGUE		29-05-1992	MARTINEZ NAVARRO A.
CATEGORY OF CITED DOCUMENTS		T : theory or principle underlying the invention E : earlier patent document, but published on, or after the filing date D : document cited in the application L : document cited for other reasons & : member of the same patent family, corresponding document	
X : particularly relevant if taken alone Y : particularly relevant if combined with another document of the same category A : technological background O : non-written disclosure P : intermediate document			

EPO FORM 1503 03.82 (P0407)