



Europäisches Patentamt  
European Patent Office  
Office européen des brevets



Publication number: **0 547 713 A1**

**EUROPEAN PATENT APPLICATION**

Application number: **92203959.9**

Int. Cl.<sup>5</sup>: **D01H 11/00**

Date of filing: **16.12.92**

Priority: **19.12.91 IT MI913418**

Inventor: **Mirri, Alessandro**  
**Via Emilia Ponente, 9**  
**I-40026 Imola (Bologna)(IT)**  
Inventor: **Vernocchi, Vittorio**  
**Via Cornacchia, 3**  
**I-40026 Imola (Bologna)(IT)**

Date of publication of application:  
**23.06.93 Bulletin 93/25**

Designated Contracting States:  
**AT BE CH DE DK ES FR GB GR IE LI LU MC**  
**NL PT SE**

Representative: **De Carli, Erberto et al**  
**ING. BARZANO' & ZANARDO MILANO S.p.A.**  
**Via Borgonuovo, 10**  
**I-20121 Milano (IT)**

Applicant: **SAVIO S.p.A.**  
**Via Udine 105**  
**I-33170 Pordenone(IT)**

**Suction system for ring spinning machines.**

A suction system for textile machines, in particular for ring spinning machines, comprising an upper manifold channel (2) operating in cleaning the spinning machine drafting rollers (15), and also comprising, along the entire length of the spinning machine, internal walls (1,3) which converge in the direction of floor-level ducting (6) put under vacuum by the central suction system of the factory, said converging internal walls (1,3) being sufficiently raised from the level of the floor (8) on which the spinning machine rests, to allow energetic lateral draw-in of the air surrounding the spinning machine.

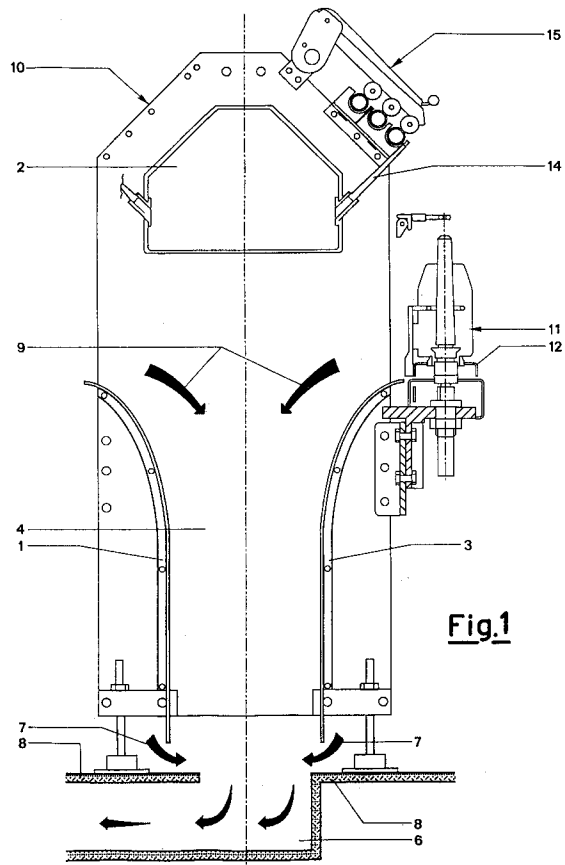

**Fig.1**

**EP 0 547 713 A1**

This invention relates to a suction system for ring spinning machines, the system being arranged to remove trash, fibre fluff and broken threads from the space surrounding the spinning faces. Said ring spinning machines normally comprise a plurality of working positions on two opposing faces, and are therefore very long.

Textile machines comprise suction ducts for the most varied purposes, for example to clean determined parts of the machine, to remove fibre trash and to draw off excessive yarn ends or pieces of cut yarn or the like. It is well known that in drafting systems of spinning machines, a fibre bundle consisting of an assembly of fibres of varying lengths is subjected to considerable traction stresses resulting in separation of a certain quantity of in particular short fibres and the formation of trash. It is therefore necessary to clean the drafting members and remove the flying fibrillae and fibres and the trash from the various machine parts and from the yarn under formation. It is also necessary to draw off and remove any pieces of broken yarn.

In this case the suction action has to be effective and uniform along the entire spinning face. In addition, the spinning faces of ring spinning machines are of considerable horizontal extension of some tens of metres, as the spinning spindles can be present in a quantity of the order of a thousand, one following the other.

The cross-sectional area of the air suction duct and the power of the pneumatic system therefore become relatively large, with consequent high system and operating costs. In addition, because of the considerable length of ring spinning machines, the continuous draw-off of trash, fibres and broken threads in known systems is insufficient in those regions farthest from the motor-driven suction fan or other type of suction device which provides the suction action. The air throughput in a central suction system, in which a suction duct extends along the entire spinning face to serve all the spinning spindles via suction nozzles or slits, is represented by the total air quantity necessary in order to achieve an energetic suction action at the spinning spindles.

Problems occur in known constructions, such as the retention of a certain number of broken fibres and threads in the suction tubes acting on the spinning spindles in those regions farthest from the fan in the machine headstock.

Fibres, dust and broken threads which have not been properly drawn off from the suction tubes often trigger their clogging, so blocking the suction action required for continuous cleaning of the spindles, which are hence subjected to progressive deposition of fibre trash on their various parts and on the yarn under formation. This results in yarn irregularities and defects which reduce its quality,

such irregularities leading in the limit to yarn breakage during the formation stage or during subsequent yarn processing stages.

The maintenance and cleaning of the suction slits requires considerable attention by the service personnel, who are required to work without any established timetable. It is understandable that work carried out on a selective or random basis without an established timetable leads to low labour efficiency.

An object of the present invention is to provide a suction system for removing fibre trash and broken fibre pieces in spinning machines which is free of the aforesaid drawbacks and is able to perform its function with greater effectiveness and for a longer time, without requiring frequent maintenance.

A further object of the present invention is to rationalize the construction of the suction system of a ring spinning machine, both in terms of its capacity and of its suction efficiency in effectively removing fibrils and floating yarn pieces from the suction spindles.

A further object of the present invention is to provide a pneumatic suction system of new while at the same time simple concept, which makes it possible to put under suction several regions which integrate and complete the entire suction operation with further functions required for the particular application underway.

These and further objects of the invention, which will be more apparent during the course of the description, are attained by the suction system of the present invention arranged on a spinning machine of considerable longitudinal extension, in particular a ring spinning machine, wherein said suction system comprises, along the entire length of the spinning machine, internal walls which converge in the direction of a mouth at the floor-level opening of ducting put under vacuum by the central suction system of the factory, said converging internal walls being sufficiently raised from the level of the floor on which the spinning machine rests, to allow energetic lateral draw-in of the air surrounding the spinning machine.

One embodiment of the invention is described in detail and further clarified hereinafter by way of non-limiting example with reference to the figures of the accompanying drawing.

Figure 1 is a schematic sectional view perpendicular to the longitudinal axis of the spinning machine, showing the upper manifold channel which operates in cleaning the drafting rollers, and the profile of the internal walls which converge in the direction of a mouth at the floor-level opening of ducting put under vacuum by the central suction system of the factory.

Figure 2 is a front isometric schematic view of a longitudinal portion of the ring spinning machine suction system of the present invention.

In the figures, corresponding parts or parts with identical functions carry identical reference characters for simplicity.

The various units and the equipment which operate in forming the yarn in the ring spinning machine, into which the suction system of the present invention is incorporated, are neither illustrated nor is their operation described, as they are already known and do not concern the operation of the present invention.

In the accompanying drawings:

- 10 schematically represents the ring spinning machine, which during spinning operates on two opposing faces with a large plurality of working positions, and is hence of considerable longitudinal extension; 15
- 2 is the upper suction manifold channel of box structure 5, put under vacuum by a motor-driven fan (not shown) positioned at one end of the spinning machine 10. Said manifold channel 2 is arranged to apply suction action for cleaning the drafting units 15 via tubes 14; 20
- 1 and 3 are the walls internal to the spinning machine 10, said internal walls defining a space 4 converging in the direction of a mouth at the opening in the floor 8 of ducting 6 put under vacuum by the central suction system (not shown) of the factory; 30
- 9 are arrows indicating the direction of the air stream which provides energetic suction in proximity to the known spinning spindles 11 and ring carrying benches 12; 35
- 7 are arrows indicating the direction of the air stream below the spinning machine, said stream 7 being drawn in by the suction present in the ducting 6. 40

The operation of the suction system of the present invention shown in the figure of the accompanying drawings is easily deduced.

The suction fan which puts the channel 2 under vacuum and the filter elements (not shown) are positioned at the end of the spinning machine 10. 45

The fibre trash and the dust present around the drafting unit 15 are drawn off by the slit in the tube 14 and conveyed into the manifold channel 2 which conveys them within its air stream to the end of the spinning machine 10 where they are retained by the filter surfaces. Simultaneously during the spinning process, the fibre trash, dust and broken yarn pieces present in proximity to the spinning spindle 11 are conveyed into the air stream 9, which conveys them together with the fibre trash of the air stream 7 into the ducting 6 of the factory suction system. 50  
55

Modifications in terms of detail can be made to the suction system of the present invention, but without leaving the scope of the invention.

## 5 Claims

1. A suction system for ring spinning machines, comprising an upper manifold channel extending along the entire spinning face and operating in cleaning the drafting rollers, characterised by comprising, along the entire length of the spinning machine, internal walls which converge in the direction of a mouth at the floor-level opening of ducting put under vacuum by the central suction system of the factory, said converging internal walls being sufficiently raised from the level of the floor on which the spinning machine rests, to allow energetic lateral draw-in of the air surrounding the spinning machine. 20

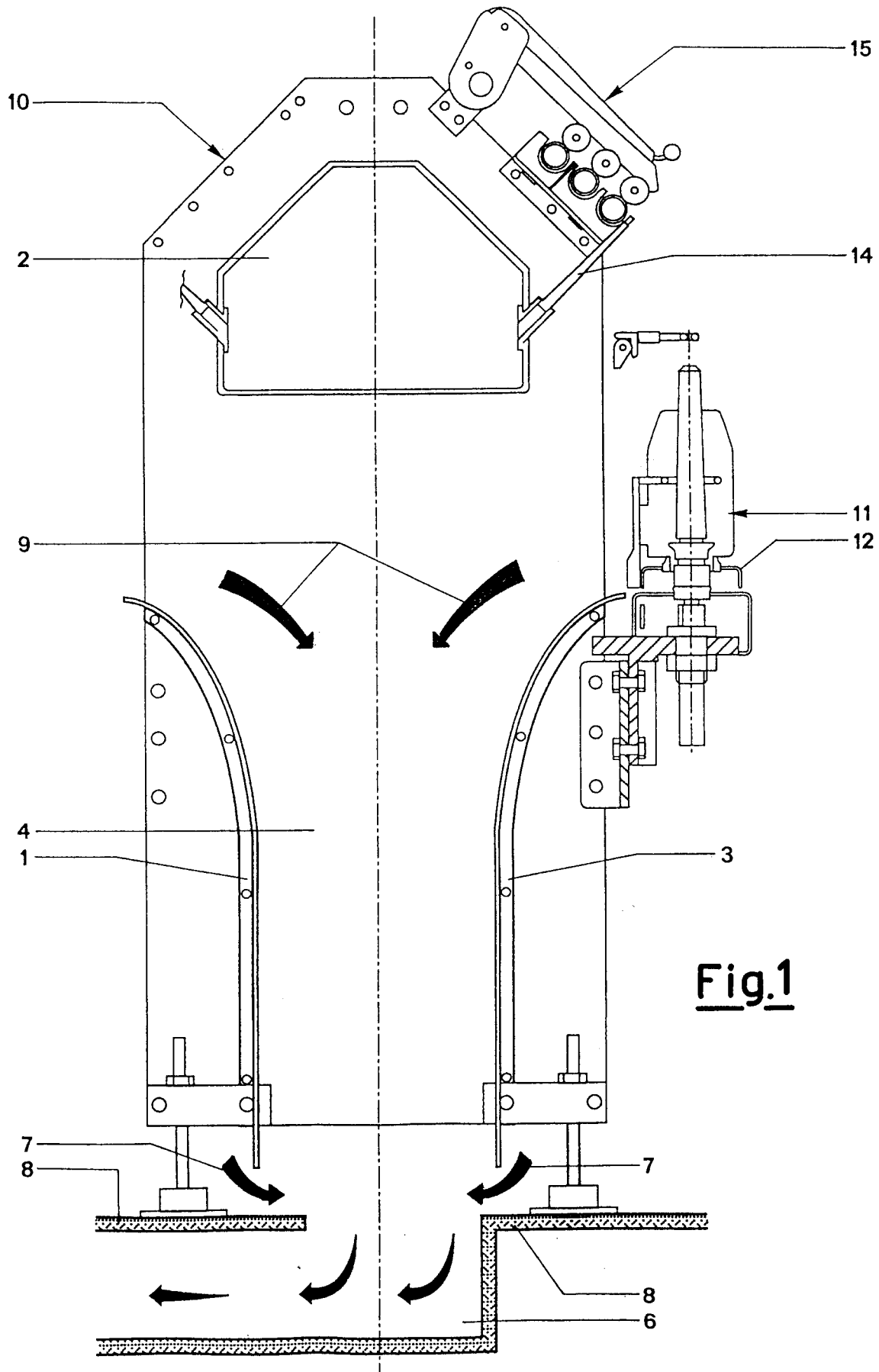

**Fig.1**

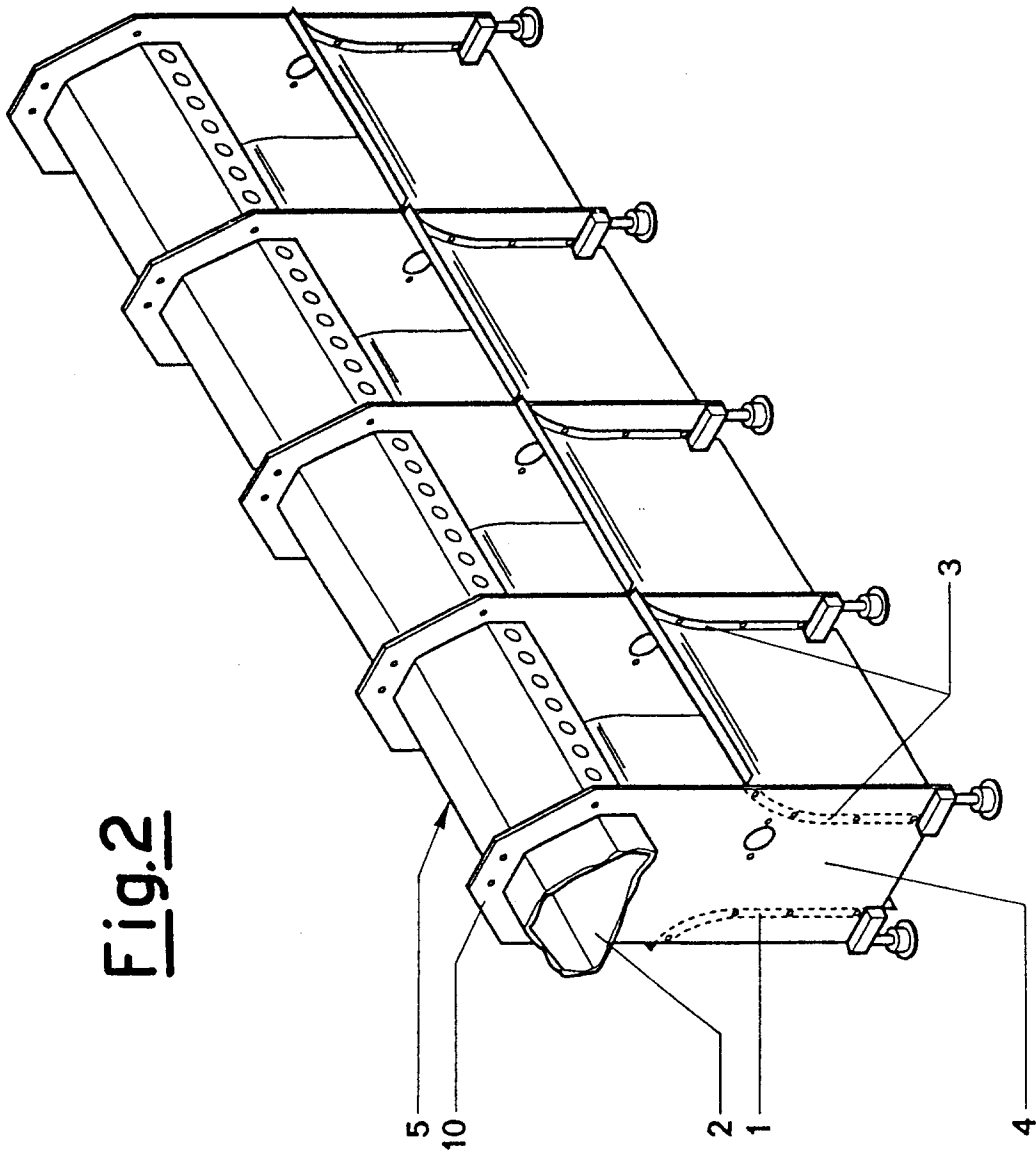

**Fig.2**



European Patent  
Office

EUROPEAN SEARCH REPORT

Application Number

EP 92 20 3959

DOCUMENTS CONSIDERED TO BE RELEVANT			
Category	Citation of document with indication, where appropriate, of relevant passages	Relevant to claim	CLASSIFICATION OF THE APPLICATION (Int. Cl.5)
A	DE-U-8 908 921 (ZINSER TEXTILMASCHINEN) * figures *	1	D01H11/00
A	DE-A-2 903 139 (W. SCHLAFHORST & CO.) * the whole document *	1	
A	EP-A-0 395 591 (HOWA MACHINERY) * figures 1,2,6,13 *	1	
A	PATENT ABSTRACTS OF JAPAN vol. 011, no. 262 (C-442)(2709) 25 August 1987 & JP-A-62 062 935 ( NISSHINBO IND ) 19 March 1987 * abstract *	1	
A,P	EP-A-0 487 120 (SAVIO) * figure 2 *	1	
The present search report has been drawn up for all claims			TECHNICAL FIELDS SEARCHED (Int. Cl.5)
			D01H B65H
Place of search	Date of completion of the search	Examiner	
THE HAGUE	25 MARCH 1993	RAYBOULD B.D.J.	
CATEGORY OF CITED DOCUMENTS		T : theory or principle underlying the invention E : earlier patent document, but published on, or after the filing date D : document cited in the application L : document cited for other reasons ..... & : member of the same patent family, corresponding document	
X : particularly relevant if taken alone Y : particularly relevant if combined with another document of the same category A : technological background O : non-written disclosure P : intermediate document			

EPO FORM 1503 03.82 (P/9001)