

19



Europäisches Patentamt
European Patent Office
Office européen des brevets



11 Publication number: **0 548 057 A1**

12

EUROPEAN PATENT APPLICATION

21 Application number: **93200371.8**

51 Int. Cl.⁵: **B65B 29/02, B65B 9/02**

22 Date of filing: **13.04.90**

This application was filed on 11 - 02 - 1993 as a divisional application to the application mentioned under INID code 60.

30 Priority: **28.04.89 GB 8909846**

43 Date of publication of application: **23.06.93 Bulletin 93/25**

60 Publication number of the earlier application in accordance with Art.76 EPC: **0 422 157**

84 Designated Contracting States:
AT BE CH DE DK ES FR GB IT LI LU NL SE

71 Applicant: **A.G. (PATENTS) LIMITED**
24 Portland Place
London, W1N 4BB(GB)

72 Inventor: **Kenney, Alan George**
24 Chapmans Way Over
Cambridgeshire CB4 5PZ(GB)
Inventor: **Wood, John David**
42 Providence Way Waterbeach
Cambridgeshire CB5 9OJ(GB)

74 Representative: **Davies, Christopher Robert et al**
Frank B. Dehn & Co. Imperial House 15-19
Kingsway
London WC2B 6UZ (GB)

54 Manufacturing infusion packages.

57 A method and apparatus for manufacturing infusion packages such as tea or coffee bags of predetermined shape, comprises means for dosing discrete piles 7 of infusion on a first moving web 4, means 8 for sealing a second web 5 over the first to form a consolidated web with discrete infusion containing pockets 3, a co-rotating roller cutting device having cutting means and recess means to cut packages of predetermined shape e.g. circular from the web, a suction device 15 for collecting waste web and maintaining downstream web tension to transport the cut packages to a removal device 50,51 operable to stamp the packages downwardly into stacking chambers 49.

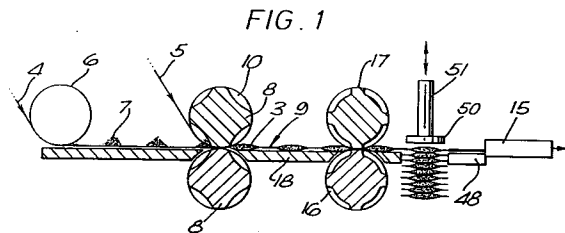

EP 0 548 057 A1

The present invention is generally concerned with infusion packages such as tea and coffee bags and similar bags containing herbal or other infusions. In particular the invention relates to an apparatus for and a method of manufacturing infusion packages and to a novel form of infusion package made by such apparatus and method.

A known method and apparatus for producing infusion packages such as tea bags, comprises dosing discrete piles of infusion at spaced intervals onto a rapidly moving paper web, and sealing a second web over the first web to produce a two ply web having a plurality of discrete pockets containing infusion. The web is then severed by means of laterally and longitudinally orientated knives into individual packages, or pairs of packages separated by a serrated cut, for discharge or packing. Such a method enables continuous fabrication of infusion packages at a very high production rate which is essential for the cost-effective manufacture of e.g. tea bags for sale in the general market place.

As discussed above, in known apparatus of this type the packages are severed from the two ply web by knives and as a consequence the infusion packages are square or rectangular, the pocket spacings and web dimensions being such that the entire web is cut into the individual packages or package pairs without leaving any waste web. For this reason, infusion packages such as tea and coffee bags which have been mass produced at high production rates for sale on the general market have traditionally been rectangular.

Viewed from a first aspect, the invention provides apparatus for manufacturing infusion packages of a predetermined shape, comprising means for dosing infusion in discrete piles onto a first moving web, means synchronised with the dosing means for sealing a second moving web over said first web to produce a travelling two ply web having a plurality of discrete pockets containing infusion, and a web cutting device comprising cooperating co-rotating rollers having recess means adapted to accommodate successive infusion filled pockets and cutting means arranged around said recess means for cutting out each said pocket into a package of predetermined shape, means for removing said cut out packages from the travelling two ply web, and means downstream of the cutting device for collecting the remainder of the web after the packages have been removed.

Viewed from a second aspect, the invention provides a method of manufacturing infusion packages of a predetermined shape, comprising the steps of dosing an infusion in discrete piles onto a first moving web, sealing a second moving web over said first web to produce a travelling two ply web having a plurality of discrete pockets contain-

ing infusion, and cutting said web into packages having said predetermined shape by passing the web through a roller cutting device having cooperating co-rotating rollers with recess means which accommodate successive infusion filled pockets and cutting means arranged around said recess means for cutting out each said pocket into a package of predetermined shape, removing said cut out packages from the travelling two ply web, and collecting the remainder of the web after the packages have been removed.

Such an apparatus and method represents a completely new departure from the prior art in that, whilst a continuous high speed production rate may be maintained, infusion packages such as tea bags can be provided with shapes other than rectilinear. The presently preferred packages are substantially round, and a preferred embodiment of the invention has enabled for the first time manufacture of substantially round tea bags at a cost-effective high production rate for sale on the general market place, such tea bags being attractive to the consumer.

To maximise production rate, the rollers preferably have a plurality of recesses and corresponding cutting means arranged both circumferentially and in the width direction. This allows a substantial number of packages to be produced per revolution of the rollers. The number of cutting means may vary, e.g. 2 to 10 around the circumference and 1 to 5 across the width of a roller.

In one embodiment the recess means comprises recesses formed on both rollers, and the relative angular orientation of the rollers is such that the or each recess pair on the respective rollers cooperate to form together a recess for accommodating the pockets on the webs, as they pass between the rollers. It is also possible that recesses may be formed only on one of the rollers with the other roller being plain.

It is envisaged that the rollers could act as a rotating punch and die, with cutting edges on both rollers forming a cutting action. Alternatively, a cutting edge on one roller could bear on a resilient surface of the other. Preferably, however, the cutting means is formed by a lip or ridge raised around the recess of one of the rollers (the cutting roller), the lip or ridge co-operating with a hard smooth surface of the opposed roller (anvil roller). The lip or ridge defines the predetermined shape of the packages. Preferably the smooth surface is provided around a recess on the anvil roller.

In a preferred embodiment the sealing means comprises co-rotating heated rollers through which the webs are passed and which, as with known machines of this type, include raised areas which define the seal areas, the webs including suitable thermoplastic materials for heat sealing. In accor-

dance with the invention the raised areas preferably define a seal shape which matches the predetermined shape of the packages e.g. round. It is envisaged that the sealing means may be combined with the web cutting device by providing the cutting rollers with heating means and raised seals adjacent the cutting means. Clearly, this would provide excellent registration between the cut and the seal. However, a potential drawback with this approach is that the heating of the rollers could be detrimental to the cutting edge of the cutting means which must be high quality to cut material cleanly.

Preferably, therefore, the cutting rollers and sealing rollers are separate and are synchronised with each other to ensure that the sealed pockets produced by the sealing rollers engage correctly with the cutting rollers so that the cutting may be performed only on the sealed portions of the web leaving a continuously sealed area around the perimeter of the package of predetermined width and controlled tolerance. To this end, the sealing and cutting rollers have synchronised speeds, with the phase and relative lateral position of the cutting rollers preferably being adjustable with respect to the sealing rollers. As discussed, the seal produced between the webs preferably matches the shape of the final packages. Thus, for circular packages, a circular seal preferably surrounds each pocket of infusion.

As discussed above, with known techniques for producing rectilinear packages, the whole of the two ply web is effectively converted into packages and no waste web is produced. In accordance with the invention, on the other hand, web remaining after the packages have been severed is collected so that the integrity of the web may be maintained before and after the cutting operation. In a particularly advantageous embodiment, the means for collecting the remaining web is effective to maintain a degree of tension in the web downstream of the cutting device whereby the web (which will become waste) surrounding the cut out packages is effective to transport the packages to the package removing means. A particularly preferred collecting means comprises a suction system which is advantageously adjustable to provide desired tensioning of the web downstream of the cutting device and which may include a slot like inlet end for receiving the moving web communicating with a conduit for waste removal. A roller system has been proposed in place of a suction system.

In a preferred embodiment, the package removing means comprises a reciprocating stamping member or members whose movement is synchronised with the movement of the cutting device, the member or members urging the packages from the moving web, preferably downwardly into a

stacking chamber arranged below. From the stacking chamber, the packages may be transferred automatically to cartons or boxes. The lower ends of the stamping members which engage the packages are preferably of smaller cross-section than the packages so that the members do not foul on the web material surrounding the packages as the packages are stamped from the web. The two ply web preferably is supported by platforms upstream and downstream of the cutting device, the downstream platform being apertured or interrupted beneath the package removing means to permit downward displacement of packages from the moving tensioned web downstream of the cutting device. The use of a downstream web support platform itself represents a completely new departure from known apparatus in which all of the web is cut into packages and therefore no web support has been provided downstream of the cutters.

The dosing means for the infusion may comprise a dosing roller synchronised with the sealing rollers of the preferred embodiment in a known manner.

The invention extends to an infusion package, such as a substantially round tea or coffee bag, made by the aforesaid method and apparatus.

The preferred web collection system discussed above itself represents a completely new departure from the prior art in the context of infusion package manufacture, which may have application independently of the above aspects of the invention e.g. if a reciprocating punch cutting means was used in place of the roller cutting device. Accordingly, a still further aspect of the invention provides a method of manufacturing infusion packages of predetermined shape, comprising dosing infusion in discrete piles onto a first moving web, sealing a second moving web over the first web to produce a travelling two ply web having a plurality of discrete pockets containing infusion, cutting the travelling two ply web into packages having the predetermined shape at a cutting station, the web being fed to a suction waste web removal means downstream of the cutting station, the suction means maintaining tension in the web downstream of the cutting station whereby the web portions surrounding the packages which become waste are effective to transport the packages to a package removal means between the cutting station and waste web removal means. The invention extends to apparatus for carrying this aspect of the invention out.

A preferred embodiment of the invention, for manufacturing circular tea bags, will now be described, by way of example only, with reference to the accompanying drawings wherein:

Figure 1 shows, schematically, in side elevation, apparatus in accordance with the invention;

Figures 2 is a schematic perspective view of the apparatus with certain parts removed for clarity; Figure 3 is a view similar to Figure 2 but showing other components of the preferred embodiment; and

Figure 4 shows in front elevation the cutting rollers of Figure 3.

With reference to Figure 1, a web 4 of heat sealable filter paper is fed around a roller 6 of a dosing device (of known type) which deposits discrete piles of tea 7 on the moving web. Web 4 and a second moving filter web 5 are then brought together and pass through the nip of heated co-rotating sealing rollers 8, driven in synchronisation with roller 6, which join the strips together to form a two ply web 9 having discrete sealed pockets 3 containing tea. This general arrangement is known in the art and will not accordingly be discussed in more detail here.

Figure 3 shows the heated rollers 8 suitable for use in the present embodiment for producing substantially circular tea bags. Each roller 8 is provided with two rows of substantially circular pockets 10 arranged at equispaced intervals around the periphery of the roller. Of course, other numbers or arrangements of pockets would be quite possible. The rollers are rotatably carried by suitable bearing means (not shown) and driven via an intermeshing sprocket arrangement 11. In operation, as the rollers rotate, the raised portions 12 surrounding the pockets 10 pinch the webs 4 and 5 together and by virtue of their heat melt a sealing material, for example polypropylene, provided on the webs to form a two ply web having a plurality of discrete sealed pockets 3 containing tea. The operation of the sealing rollers is synchronised (in a known manner) with that of the dosing device 6 so that the tea doses deposited on the web 4 are surrounded by the pockets 10 during the heat sealing.

After the consolidated two ply web 9 leaves the sealing means 8, it passes to a cutting device 13, which will be described in more detail later. The cutting device 13 cuts substantially circular bags from the web 9 which will however still surround the bags after they leave the cutting device 13. The bags are transported by the web in this manner to a stacking and packing station 14, which will be described in greater detail later in the specification. When the bags have been separated from the web, the waste web material is removed by a suction device 15.

Returning now to the cutting device 13, this is shown in greater detail in Figures 2, 3 and 4. The cutting device comprises two co-operating, co-rotatable rollers 16, 17. The web 9 is fed into the pinch between the rollers along an entry platform 18.

The roller 17 is supported on a bearing which locates in vertical slots (not shown) running down the length of the opposed limbs 28, 29 of a support housing 30, with the upper roller 17 resting on the lower roller 16 which is carried by a fixed bearing. A clamp plate 31 is connected across the top of the limbs 28, 29 and mounts a threaded bolt 32 in a threaded bore. This bolt 32 acts via a pressure roller assembly 34 on the cutting rollers 16, 17, so that the contact pressure between the rollers 16, 17 may be raised or lowered by either tightening or loosening the bolt 32. The pressure roller assembly comprises rollers 61 at each end which act on the outer portions 62 of the cutting roller 17.

The design of the rollers 16, 17 can be clearly seen from Figure 4. Both rollers 16, 17 have a plurality of recesses 35, 36 formed in their respective surfaces, in two rows, the recesses in each row being equispaced around the respective roller circumference. The recesses are substantially circular in shape and are of approximately the same maximum depth but of somewhat different cross-section. They could be of different depths or shapes depending on the particular shape of bag being produced. The recesses 35 on the upper roller 17 are of greater area than those 36 on the lower roller 16 and will thus completely overlie those recesses as the rollers rotate and co-operate. They could instead be of the same area or smaller than those on the lower roller without changing the operational principles. The recesses 35, 36 co-operate to provide spaces for accommodating the tea containing portions of the pockets formed in the web 3. As described in the introduction, the number of recesses can vary. The illustrated cutting and sealing rollers are of similar diameter, but these may be different with the relative rotation speeds adjusted accordingly.

A substantially circular cutting edge 37 is formed around each recess 35 on the upper roller which therefore acts as a cutting roller. This edge 37 is constituted by a relatively low and narrow raised lip running around the recess. The top of the lip is sufficiently sharp to provide the desired cutting effect as a result of the pressure acting on the lip during cutting by virtue of the contact pressure set by the adjusting bolt 32. The cutting edges 37 bear against the smooth surface around the recesses 36 of the lower roller 16 which effectively acts as a rotating anvil. With exactly circular cutting edges the resultant bags may be very slightly elliptical as a result of stretching of the web as it passes through the cutting rollers. This may not be readily noticeable, but could be compensated for by making the cutting edges slightly elliptical if desired.

In the cutting operation, the web 9 having discrete sealed pockets containing tea passes succes-

sively between the rollers 16, 17. The cutting edge 37 acts with the anvil surface on roller 16 to cut out the bag, the space formed between the respective recesses 35 and 36 accommodating the tea containing portion of the bag, as it is cut.

To ensure satisfactory operation, the speed of rotation of the rollers 16, 17 is linked to that of the sealing rollers 8 by suitable gearing mechanism 38 shown schematically in Figure 3. The position of the cutting rollers 16,17 is variable laterally with respect to the sealing rollers 8. To this end, an adjustment wheel 70 is threadedly engaged in housing arm 28. When the wheel 70 is screwed in or out, the roller 17 moves laterally in the housing 30. The relative phase of the sealing rollers 8 and cutting rollers 16,17 may be adjusted by means of a clamping screw in slot arrangement 39 which releaseably interengages a pair of intermediate sprockets 40,41 meshing with the drive sprockets for the respective sets of rollers.

By proper setting of the relative lateral position and phase of the cutting rollers, the tea containing pockets on the web 9 will enter the cutting device correctly with the tea bearing portions accommodated within the recesses 35, 36 of the rollers 16, 17 and the sealed portions extending outwardly thereof to be cut by the cutting edge 37.

After the web 9 has been cut into individual bags, the bags are carried out of the cutting device 13 both by the momentum imparted by the cutting rollers 16, 17 and by the waste web material which still surrounds the bags and is placed in tension by the suction device 15.

After leaving the cutting means, the bags pass to the stacking station 14. This comprises stacking chambers 49 arranged side by side and open at their tops. The web in this region is supported by a further platform 48 which is apertured above the stacking chambers. As the bags pass over the tops of the chambers, they are pushed into the chambers by stamper members 50. These members, which are preferably circular in section and of smaller diameter than the tea bags, are mounted on the end of shafts 51 which reciprocate up and down. If other shaped bags are produced the section of the members preferably matches the bag shape. When a predetermined number of bags have entered the chambers 49, the stacks then are released from the bottom of the stacker into boxes (not shown). As shown in Figure 3, the upper ends of the shafts 51 of the stamper members 50 are resiliently engaged with rotating cam members 63 carried by cam shaft 64 which is coupled to the drive sprocket mechanism 38 via chain drive 65 which engages with a sprocket wheel 66 mounted on the drive shaft of the upper cutting roller 17. In this way the reciprocal movement of the stampers may be synchronised with the rotation of the cut-

ting rollers. Power drive to the system can be imparted via any one of the drive sprockets of the mechanism 38.

Immediately after the stacking station is a waste web removal device 15. This comprises a conduit 54, which tapers to a slot like open mouth 55 at one end, extending across the web travel path and which communicates with a suction device (not shown) at the other end. This allows for an easy and effective removal of waste from the apparatus and, moreover, maintains the tension in the web downstream of the cutting device to provide transport means for the cut out packages as described above.

The preferred embodiment can achieve a high production rate of bags, for example 1,200 to 2,500 per minute for the "two lane" web illustrated. The rollers are all rotated at high speeds, which may vary depending on roller sizes which can also vary. Speeds in the range of 200 to 500 rpm have been used in practice.

While the invention has been described with reference to production of substantially circular tea bags, it is of course applicable to other infusion packages and other shapes. Also, while the above embodiment describes cutting rollers which are each formed with recesses and which are driven together by intermeshed gearing, it will be appreciated that in another embodiment, recesses could be formed only on the cutting roller 17 with the roller 16 being plain. In such a case it is possible to dispense with the gearing between the rollers 16, 17 and to allow the roller 16 to be driven by friction.

Claims

1. Apparatus for manufacturing infusion packages of a predetermined shape, comprising means for dosing infusion in discrete piles onto a first moving web, means synchronised with the dosing means for sealing a second moving web over said first web to produce a travelling two ply web having a plurality of discrete pockets containing infusion, and a web cutting device comprising cooperating co-rotating rollers having recess means adapted to accommodate successive infusion filled pockets and cutting means arranged around said recess means for cutting out each said pocket into a package of predetermined shape, means for removing said cut out packages from the travelling two ply web, and means downstream of the cutting device for collecting the remainder of the web after the packages have been removed.
2. Apparatus as claimed in claim 1 in which the recess means comprises recesses provided on

both rollers.

3. Apparatus as claimed in claim 1 in which the recess means comprises recesses provided in only one of said rollers. 5
4. Apparatus as claimed in claim 1, 2 or 3 in which the cutting means is formed by a ridge or lip raised around the recess of one of the rollers and cooperating with a hard smooth surface of the opposed roller. 10
5. Apparatus as claimed in any preceding claim wherein the sealing means comprises co-rotating heated rollers separate from and synchronised with the cutting rollers. 15
6. Apparatus as claimed in any preceding claim in which the means for collecting the web is effective to maintain a degree of tension in the web downstream of the cutting device whereby the web (which will become waste) surrounding the cut out packages is effective to transport the packages to the package removing means. 20
7. Apparatus as claimed in claim 6 wherein the collecting means comprises a suction system having an elongate inlet aperture configured to receive the waste web material. 25
8. Apparatus as claimed in any preceding claim wherein the package removing means comprises a reciprocating stamping member or members whose movement is synchronised with the movement of the cutting device, the member or members urging the packages from the moving web. 30
9. Apparatus as claimed in claim 8 wherein the lower end of the member or members are of smaller cross-section than the packages. 40
10. Apparatus as claimed in any preceding claim wherein the web is supported by a platform between the cutting device and collecting means, the platform being interrupted or apertured beneath the package removal means. 45
11. A method of manufacturing infusion packages of a predetermined shape, comprising the steps of dosing an infusion in discrete piles onto a first moving web, sealing a second moving web over said first web to produce a travelling two ply web having a plurality of discrete pockets containing infusion, and cutting said web into packages having said predetermined shape by passing the web through a roller cutting device having co-operating co-

rotating rollers with recess means which accommodate successive infusion filled pockets and cutting means arranged around said recess means for cutting out each said pocket into a package of predetermined shape, removing said cut out packages from the travelling two ply web, and collecting the remainder of the web after the packages have been removed.

12. A method as claimed in claim 11 wherein tension is maintained in the web downstream of the cutting device so that the web (which will become waste) surrounding the packages is effective to transport the packages to the position where they are removed from the web.
13. A method as claimed in claim 12 wherein the tension is maintained by a suction means.
14. A method of manufacturing infusion packages of predetermined shape, comprising dosing infusion in discrete piles onto a first moving web, sealing a second moving web over the first web to produce a travelling two ply web having a plurality of discrete pockets containing infusion, cutting the travelling two ply web into packages having the predetermined shape at a cutting station, the web being fed to a suction waste web removal means downstream of the cutting station, the suction means maintaining tension in the web downstream of the cutting station whereby the web portions surrounding the packages which become waste are effective to transport the packages to a package removal means between the cutting station and waste web removal means.
15. Apparatus for carrying out the method as claimed in claim 14 comprising a web cutting station, a suction web removal means downstream of the cutting station, and a package removal means arranged between the cutting station and suction means.
16. An infusion package made by an apparatus or method as claimed in any preceding claim.
17. Apparatus for manufacturing infusion packages, comprising means for dosing infusion in discrete piles onto a first continuously moving porous web, means synchronised with the dosing means for sealing a second continuously moving porous web over said first web to produce a travelling two ply web having a plurality of discrete pockets containing infusion, and a web cutting device comprising cooperating co-rotating rollers having recess

means adapted to accommodate successive infusion filled pockets and cutting means arranged around said recess means for cutting out each said pocket into a package, characterised in that the cutting means of the rollers are configured to produce infusion packages whose shape is such that waste web surrounds the packages formed by the cutting device, in that means are provided downstream of the cutting device for collecting the remainder of the web after the packages have been removed, such means being effective to maintain a degree of tension in the web downstream of the cutting device whereby the web (which will become waste) surrounding the cut out packages is effective to transport the packages to a position downstream of the cutting device, and in that means are located at such downstream position for removing the cut out packages from the web, such means being synchronised with the rollers of the cutting device.

5

10

15

20

25

30

35

40

45

50

55

7

FIG. 1

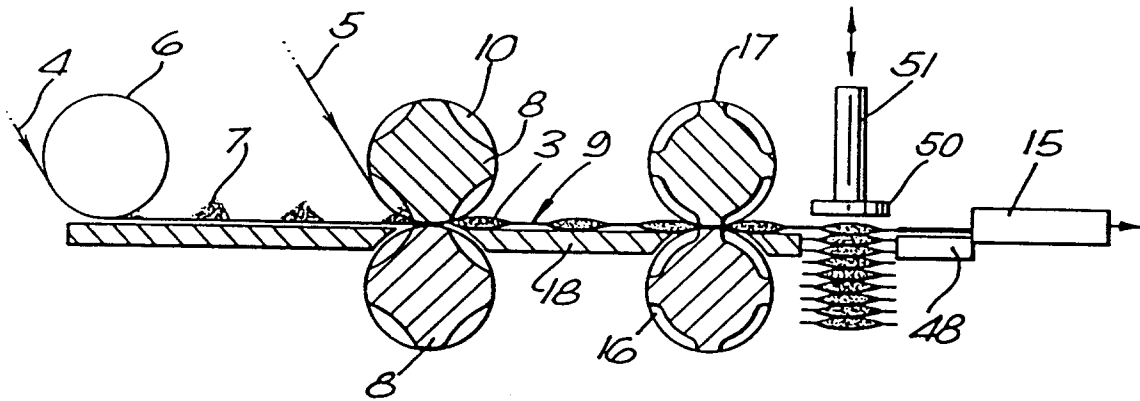
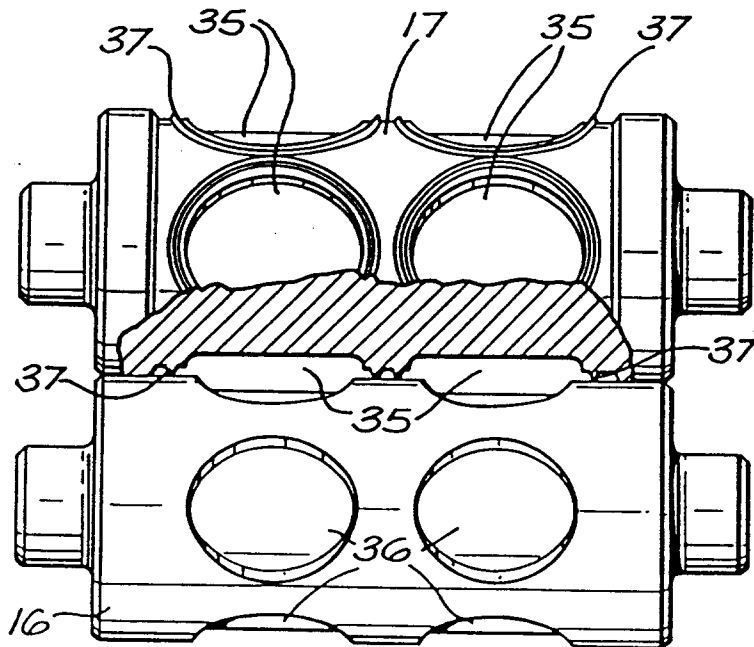

FIG. 4



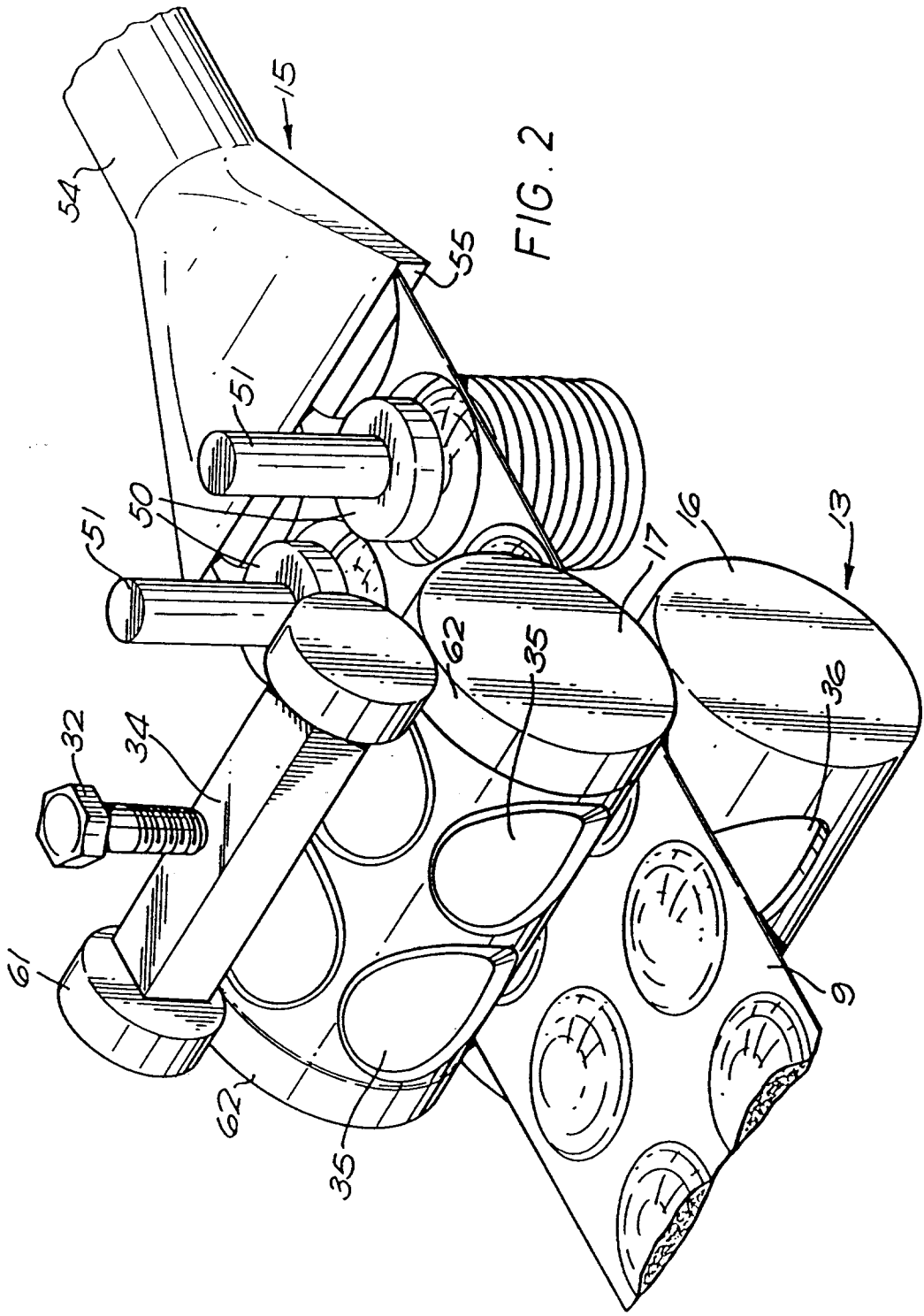

FIG. 2

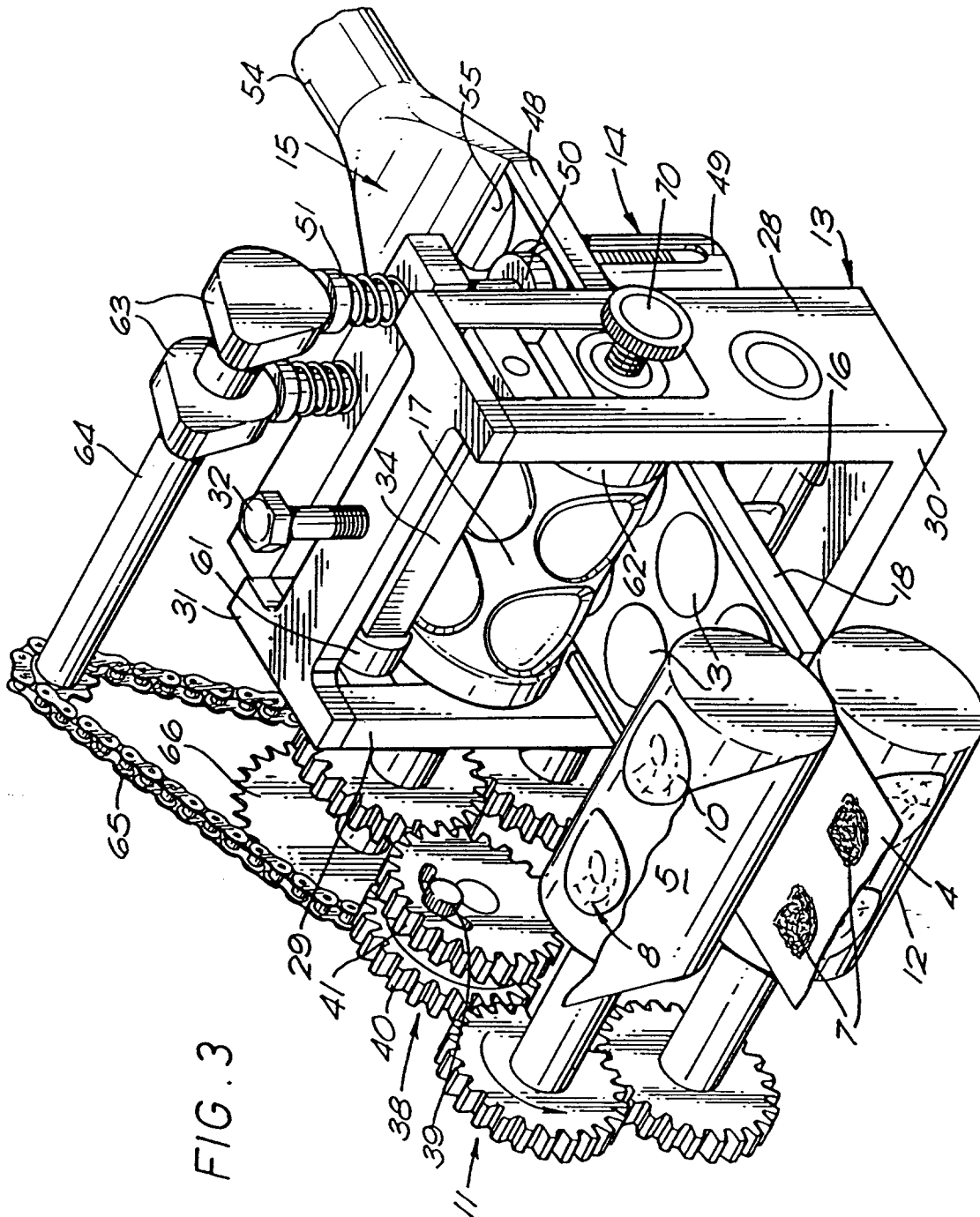

FIG. 3



DOCUMENTS CONSIDERED TO BE RELEVANT			
Category	Citation of document with indication, where appropriate, of relevant passages	Relevant to claim	CLASSIFICATION OF THE APPLICATION (Int. Cl.5)
Y	FR-A-1 341 096 (DEBELL & RICHARDSON INC.) * page 2, column 1, line 55 - page 3, column 1, line 13; figures * ---	1-8, 11-13,16	B65B29/02 B65B9/02
Y	GB-A-674 886 (IVERS-LEE) * page 2, line 100 - page 3, line 117; figures * ---	1-8, 11-17	
Y	US-A-3 762 125 (W. PRENA) * column 3, line 24 - line 54; figure 2 * ---	7,13-15, 17	
Y	GB-A-1 128 537 (HAMAC-HANSELLA) * page 2, line 28 - line 53; figures * ---	3,4	
A	DE-B-1 153 673 (F. HESSER) ---		
A	US-A-3 736 722 (H. ROSENBERG) ---		
A	US-A-4 154 636 (S. MOTOYAMA) -----		
The present search report has been drawn up for all claims			
Place of search THE HAGUE		Date of completion of the search 14 APRIL 1993	Examiner JAGUSIAK A.H.G.
CATEGORY OF CITED DOCUMENTS X : particularly relevant if taken alone Y : particularly relevant if combined with another document of the same category A : technological background O : non-written disclosure P : intermediate document T : theory or principle underlying the invention E : earlier patent document, but published on, or after the filing date D : document cited in the application L : document cited for other reasons & : member of the same patent family, corresponding document			