

19



Europäisches Patentamt
European Patent Office
Office européen des brevets



11 Publication number:

0 559 992 A2

12

EUROPEAN PATENT APPLICATION

21 Application number: **92811028.7**

51 Int. Cl.⁵: **G07D 11/00**

22 Date of filing: **29.12.92**

30 Priority: **13.03.92 CH 814/92**

43 Date of publication of application:
15.09.93 Bulletin 93/37

84 Designated Contracting States:
AT BE DE DK ES FR GB GR IT LU MC NL PT SE

71 Applicant: **TEAN AG**
Via Bossi 6
CH-6900 Lugano(CH)

72 Inventor: **Seeger, Rahel**
LI-9490 Vaduz(LI)

74 Representative: **Baggiolini, Raimondo et al**
Patent Attorneys Fiammenghi-Fiammenghi,
Via San Gottardo 15
CH-6900 Lugano (CH)

54 **Perfected machine for the counting and checking of banknotes of any size, even when overlapped.**

57 The present invention has as its object a perfected machine for the counting and checking of banknotes of any size, even overlapped, which exhibits the peculiarity of including a station for the insertion of the banknotes (2), downstream from which a traction unit (31, 32) acts on a single banknote along a direction essentially perpendicular to the longitudinal development of the banknote.

Downstream from the above mentioned traction

unit (31, 32), there is provided a conveyance unit for the banknote along a direction essentially parallel to its longitudinal development, to transport the banknote itself through a counting and checking station (55), which pilots a shunter, capable of selectively inserting the banknotes, into a collection area for the counted banknotes and into a collection area for those that are discarded.

EP 0 559 992 A2

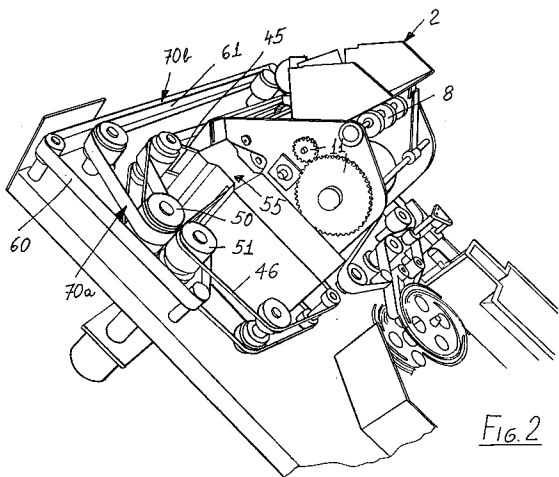

Fig. 2

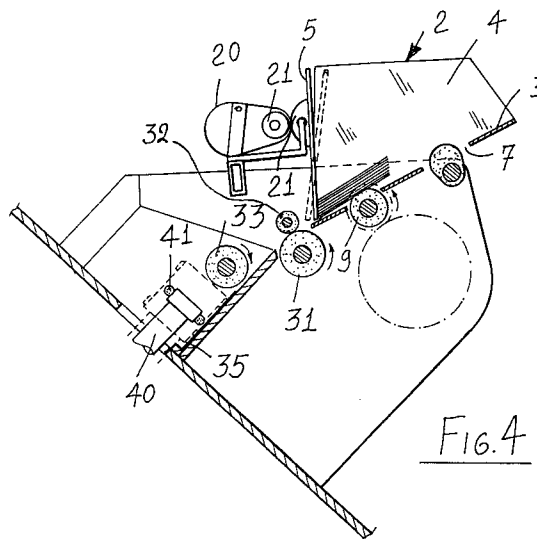

Fig. 4

The present invention has as its object a perfected machine for the counting and checking of banknotes of any size, even overlapping. It contains some relative improvements with respect to the machine described by the same applicant in European patent application no. 89810913.7.

As it is known, a problem that is presently widely experienced in the area of banking automation is that relating to the possibility of designing a machine capable of counting and checking banknotes that are inserted in random order.

The presently known solutions are not sufficient to resolve the problem, since generally the machines are pre-set for the counting and checking of a single size of banknotes, which have to be arranged in an orderly manner.

The solutions relating to machines capable of counting banknotes of different sizes, even if they are arranged in an overlapping manner, have not proved practical, inasmuch as they are subject to numerous failures, caused by defective operations.

Another drawback that can be attributed to the solutions of prior art, is the fact that such machines turn out to be remarkably complex and cumbersome, and they generally involve difficulties in use for the user.

The object proposed by the present invention is to eliminate the drawbacks indicated above, by designing a perfected machine for the counting and checking of banknotes of any size, even overlapping, which makes it possible to obtain, in a rapid and automatic manner, the identification of the value of each single banknote, as it is counted and checked, and to add up their sum and to transmit the data to a central control unit.

In the area of the object presented above, a particular purpose of the invention is to design a perfected machine which is extremely compact and structured in such way as to allow for a rapid and accurate selection and feeding of the various banknotes.

The present perfected machine makes it possible to offer the greatest guarantees of reliability and safety in use, while also making it possible to remove the counted banknotes inside of a container or box, which is closed, and thus accessible only through suitable means and by authorized persons.

The present perfected machine, moreover, is easily constructed, by using elements and materials that are readily available commercially, and it is competitive, from an economic point of view. Another important aspect of novelty with respect to the machine described in European patent application no. 89810913.7 is that, thanks to the new component parts and the new arrangement and correlation among them, the new machine can be constructed so that its overall dimensions are

greatly reduced (1/2 : 1/3) with respect to the preceding type, with all the immediately apparent advantages that result from this.

The object presented above, as well as the purposes mentioned and others, which will be demonstrated more clearly below, are attained by a perfected machine for the counting and checking of banknotes of any size, even overlapping, according to the invention, characterized in that it includes a station for the insertion of the banknotes with a maximum of 200 at a time, downstream from which a traction unit operates on each single banknote, along a direction that is essentially perpendicular to the longitudinal development of the banknote itself.

Downstream from the traction unit there is a unit for conveying the banknote along a direction that is essentially parallel to its longitudinal development, to convey it to a counting and checking station, piloting a shunter, capable of selectively introducing the banknote into a collection area for the counted banknotes and into a discard collection area.

Further characteristics and advantages of the object of the present invention will be made evident through an examination of the description of a preferred embodiment, that is however not exclusive, of a perfected machine for the counting and checking of banknotes of any size, even overlapping, illustrated in an indicative but not limiting manner, with the help of the attached drawings, in which:

figure 1 presents, diagrammatically, in perspective front view, the station for the insertion of the banknotes;

figure 2 represents the station for the insertion of the banknotes in perspective lateral view;

figure 3 represents the station for the insertion of the banknotes in perspective view, from the other side;

figure 4 represents, diagrammatically, the station for the insertion of the banknotes, seen in cross-section;

figure 5 shows the shunter;

figure 6 shows, diagrammatically, the collection areas for the counted and discarded banknotes;

figure 7 represents, in front perspective view, the collection area;

figure 8 represents, in lateral perspective view, the collection area;

figure 9 represents, diagrammatically and in cross-section, the box for the counted banknotes;

figure 10 represents the box, seen in overview;

figure 11 represents in perspective view, the sliding runners of the box.

With particular reference to the numerical symbols of the above figures, the perfected machine for the counting and checking of banknotes of any

size, even overlapping, according to the invention, includes a bearing frame, generically indicated with the reference number (1), which can exhibit any outer covering deemed to be suitable.

The machine includes a station for the insertion of the banknotes, overall indicated with the reference number (2), which exhibits an inclined plane (3), flanked by a pair of lateral walls (4), which convey the banknotes toward a frontal oscillating wall (5).

On inclined plane (3) there are slits (7), from which eccentric rollers (8) protrude, which have the function of moving the banknotes forward toward feeding rollers (9) in proximity to the oscillating wall (5).

Rollers (3) and (9) are activated by motor (10), of the step-step type, which is equipped with a pair of gears (11), for making insertion rollers (9) rotate and, on the opposite side, of a return unit, indicated with (15), which controls the rotation of the eccentric rollers.

Front wall (5) is made to oscillate by a second step-step motor (20), which activates a small friction roller (21), that engages with a semi-cylindrical roller (22) attached to the wall, so as to cause an initial oscillation, which allows for the swinging of the front wall, with the resulting possibility of inserting the banknotes toward a traction unit, indicated overall with reference number (30), and better illustrated in figure (4).

Traction unit (30) exhibits a lower traction roller (31), above which there is provided friction roller (32), which has the function of holding back banknotes that may be overlapping, so as to allow for the advance of one banknote at a time.

The banknotes, in this phase, are moved over a direction essentially perpendicular to the longitudinal development of the banknotes themselves and are inserted onto positioning roller (33), which acts on an inclined collation plane (34), which inserts the banknote against a striking edge (35).

All the rollers are moved by kinematic connections, executed by unit (15), activated by step-step motor (10).

Once the banknote has arrived against striking edge (35), it is picked up by a conveying unit, which executes a movement of the banknote over a direction essentially parallel to its longitudinal direction.

The conveying unit exhibits advancing starter shaft (40), with advancing roller (41), which, in practice, carries out a lateral movement of the banknote, over the direction parallel to the longitudinal development, in order to insert it into a belt advancer, made up of upper belts (45) and lower belts (46), which are supported by their respective conveying rollers, (50) and (51), which carry out the programmed conveyance on the belts, so that the

banknotes held between the belts are inserted under a counting and checking station, indicated with (55), which can be connected to a centralized processor.

5 On exiting counting and checking station (55), the banknote is picked up by a pair of tapes, which exhibit superposed sections.

10 These tapes, made up of upper tape (60) and lower tape (61), are moved over a certain section between belts (50) and (51) and in practice hold between themselves the banknote, causing a conveying operation to be carried out.

15 Tapes (60) and (61) move on common pulleys, indicated with (62), in the section in which the two tapes travel superposed, and on respective upper (63) and lower (64) pulleys, corresponding to the return sections of the development of the tape.

20 The tapes, in the superposition section, first carry out an ascending movement (70A), a horizontal movement (70B), and a descending movement (70C), which conveys the banknote corresponding to shunter (80) which is positioned in the separation or division area between upper tape (60) and lower tape (61), and is switched, according to the reading made by the counting station, which affords the possibility of inserting the banknotes into a discard collection area, indicated with (81), or into a collection area for the counted banknotes, indicated overall with (85).

25 Shunter (85), controlled by station (55), in the event that a banknote that has been retained does not correspond to the characteristics required, it is shifted, and is placed against lower tape (64) and, in practice, freeing the downward vertical path toward the discard collection area (81).

30 In the event the banknote that is retained corresponds to the characteristics required, shunter (80) shifts, placing it against the upper tape (60), while leaving free the path in the direction of the lower tape (61), which conveys the banknote to a pick-up belt (90).

35 This latter inserts the banknotes into a pick-up wheel, indicated with (91) and made up of a pair of flanges (92), equipped with seats (93), which move in a spiral and which, in practice, receive the various banknotes.

40 The counter-clockwise rotation of pick-up wheel (91) carries the banknotes to unthreading reference (94), which in practice, removes the banknotes from seats (93) and causes them to fall freely into collection area (85).

45 Collection area (85) is equipped with front wall (95), placed essentially vertically, and back wall (96), which has a horizontal position, when in the closed position.

50 Walls (95) and (96) are oscillating, as diagrammatically illustrated in figure (9), so they can be arranged into a closed position in which the

various banknotes accumulate on the back wall (96) or into an open position, in which the front wall rotates toward the inside and the back wall rotates upward, opening communication toward conveyance hopper (97), which inserts the banknotes into a removable collection box (100).

Walls (95) and (96) are activated by step-step motors, indicated with (95a) and (96a).

Hopper (97), as shown in figures 9 to 11, is connected with "C" runners (101), which receive box (100) in a sliding manner.

This box (100) is equipped with an upper shutter (102), which is wound and unwound by winding roller (103), supported on one end of the box.

Moreover they are provided with means for automatic closing of the shutter (102) at the time of the removal of the box.

These means consist of closing roller (110), supported above "C" runners (101), and equipped with eccentric protrusions (11), which engage with closing protrusions (112), defined at the end of the edge of the shutter.

This latter in turn exhibits central coupling element (113), placed corresponding to a closing electric valve (114), present on the frame of the box, which has the function of maintaining the shutter in the closed position, once the coupling has been carried out.

In practice, at the time of the removal of the box, protrusions (112) engage with eccentric protrusions (111) of closing roller (110); for this reason the shutter is drawn into closed position, until the central coupler (113) is connected with the electric valve (114).

In order to be able to complete the unthreading of the box, it is necessary for roller (110), and specifically its protrusions, to disengage from the closing protrusions (112).

For this purpose, sensing roller (120) is provided, which engages with one edge of the box, and it is connected, by means of lever (121) to roller (110).

At the end of the removal, roller (120) can rotate, disengaging from the box, and consequently, roller (110) can rotate.

Consequently, protrusions (111) disengage from closing protrusions (112) and it is possible to carry out the complete unthreading of the box.

It is a good time to emphasize that the box, which contains inside it the counted banknotes, remains closed and can be opened only by electric commands, suitably preset, and only by authorized persons.

At the time of the insertion of the box, this latter has its shutter open, because it has been recalled by the elastic recall means of winding roller (103) and during the insertion phase, the engagement between the box and the sensing roller

(120) triggers the rotation of the closing roller (110), which places eccentric protrusions (111) in the correct position to obtain the closing of the shutter.

In practice, therefore, the banknotes are rested on the inclined plane (3), and from there they are inserted toward the traction unit, thanks to the oscillation of the oscillating front wall (5), controlled by the second step-step motor (20), which allows for passage of the individual banknotes, also by the presence of the friction roller, which holds back the banknote on top, and only allows the banknote underneath to pass through, which is thus picked up by positioning roller (33), which acts on the reference inclined plane (34), to insert the banknote against the reference edge.

At this point, still controlled by motors that are suitably synchronized, the banknote is initially picked up by advancement shaft (40), which, by means of small roller (31), makes it move in the direction parallel to its longitudinal development until it is inserted under belts (45) and (46), which carry the banknote to the counting station (55), where the banknote is checked and, in the event the banknote does not correspond to the characteristics required, a discard signal is emitted, which provides for orienting the shutter (80), so that the banknote itself that is picked up by tapes (60) and (61), is diverted to the discard area.

On the other hand, in the event the banknote is retained as valid, it is inserted, as has been previously described, into the collection unit for the counted banknotes, by means of the pick-up wheel.

The banknotes can be accumulated on the back wall (96), which is maintained in a closed position, or else, they can be inserted into box (100), as shown above.

The machine is completed subject to electronic means of control, which afford the possibility of regulating the movement and the speed of the banknotes at will, depending on the various operations that need to be carried out.

From what has been illustrated above, it can be seen, therefore, how the invention attains the purposes proposed.

In particular, we emphasize the fact that an extremely practical and versatile machine has been made available, one capable of completely resolving all the problems connected with the counting and storage of banknotes, perfectly counted and checked.

The invention, thus conceived, is capable of numerous modifications, all falling within the scope of the invention concept.

Moreover, all the details can be substituted by other technically equivalent elements.

In practice, the materials used, as well as the contingent dimensions and shapes, can be of any

kind, depending on the requirements.

Claims

- 1.** Perfected machine for the counting and checking of banknotes of any size, even overlapped, characterized in that it includes a station for the insertion of the banknotes, with a maximum of 200 at a time, downstream from which a traction unit acts on single banknotes, over a direction essentially perpendicular to the longitudinal development of the banknote itself, and that, downstream from the traction unit, a unit for the conveying of the banknotes is provided, along a direction essentially parallel to its longitudinal development, for the conveyance from a counting and checking station, with a shunter piloting that is suitable for selectively inserting the banknote into a collection area for the counted banknotes and into a collection area for the discarded banknotes.

5
10
15
20
- 2.** Machine, according to claim 1, wherein said insertion station exhibits an inclined plane, bordered by lateral walls and by an oscillating front wall, to allow for the insertion of the banknotes toward the traction unit.

25
- 3.** Machine, according to any of the previous claims, wherein it includes the above mentioned inclined plane, and slits from which eccentric rollers protrude for the advancement and positioning of the banknotes, and insertion rollers, and that the rollers are controlled by a first step-step motor of the self-braking type.

30
35
- 4.** Machine, according to any of the previous claims, wherein it includes means for oscillating the oscillating front wall, consisting of a second step-step motor, acting on a traction roller, which engages with a semi-cylindrical roller, connected to the oscillating front wall.

40
- 5.** Machine, according to any of the previous claims, wherein the above mentioned traction unit exhibits, downstream from the oscillating front wall, a lower traction roller, above which a friction roller is provided that is suitable for holding back the banknotes on top, in order to allow for the insertion of a single banknote at a time.

45
50
- 6.** Machine, according to any of the previous claims, wherein it includes, downstream from the lower traction roller a positioning roller, provided on a reference inclined plane, which limits a striking edge, for the positioning of the banknotes.

55
- 7.** Machine, according to any of the previous claims, wherein the above mentioned conveyance unit exhibits an advancing starter shaft, equipped with a small advancing roller, placed above the banknote and the above mentioned reference inclined plane, and suitable for inserting the banknote onto belts, both upper and lower, for the conveyance of the banknote.

5
- 8.** Machine, according to any of the previous claims, wherein the above mentioned conveyance belts are suitable for inserting the banknotes underneath the above mentioned counting and checking station.

10
- 9.** Machine, according to any of the previous claims, wherein the banknote, upon exiting the counting and checking station, is inserted between an upper tape and a lower tape exhibiting a common superposed section, defined by an ascending stretch, a horizontal stretch and a descending stretch, ending in the place where the above mentioned shunting device is placed.

15
- 10.** Machine, according to any of the previous claims, wherein the above mentioned shunter is suitable for inserting the counted and checked banknotes onto a pick-up belt, that moves, for a certain distance, over a common course with the lower tape, to place the banknotes onto a pick-up wheel.

20
- 11.** Machine, according to any of the previous claims, wherein the above mentioned pick-up wheel exhibits a pair of distanced flanges, equipped with seats arranged spirally, which define the area for lodging the individual banknotes, and it is also equipped with an unwinding reference, to disengage the banknotes from the spiral-shaped seats of the above mentioned pick-up wheel.

25
- 12.** Machine, according to any of the previous claims, wherein the collection area for the counted banknotes exhibits a swinging back wall and a swinging front wall, that can be arranged, respectively in a horizontal and vertical position, under closed conditions, and can be rotated to be placed in communication with a collection box.

30
- 13.** Machine, according to any of the previous claims, wherein the collection box can be lodged in a sliding manner inside "C" runners, supporting a conveying hopper, that can be positioned corresponding to the light defined by the front and back walls, placed in the open

35

position.

14. Machine, according to any of the previous claims, wherein it includes a closing roller, equipped with eccentric protrusions and supported by "C" runners, and these eccentric protrusions can be engaged in a removable manner with closing protrusions, defined on an upper shutter of a removable box, while the shutter can be wound and unwound by an automatic winding roller supported by the box.

5

10

15. Machine, according to any of the previous claims, wherein it includes on the edge of the shutter, that can be connected, in its closed position, with an electric valve, suitable for maintaining the shutter in a stable closed position, in order to allow for its opening only by authorized persons with authorized means.

15

20

25

30

35

40

45

50

55

6

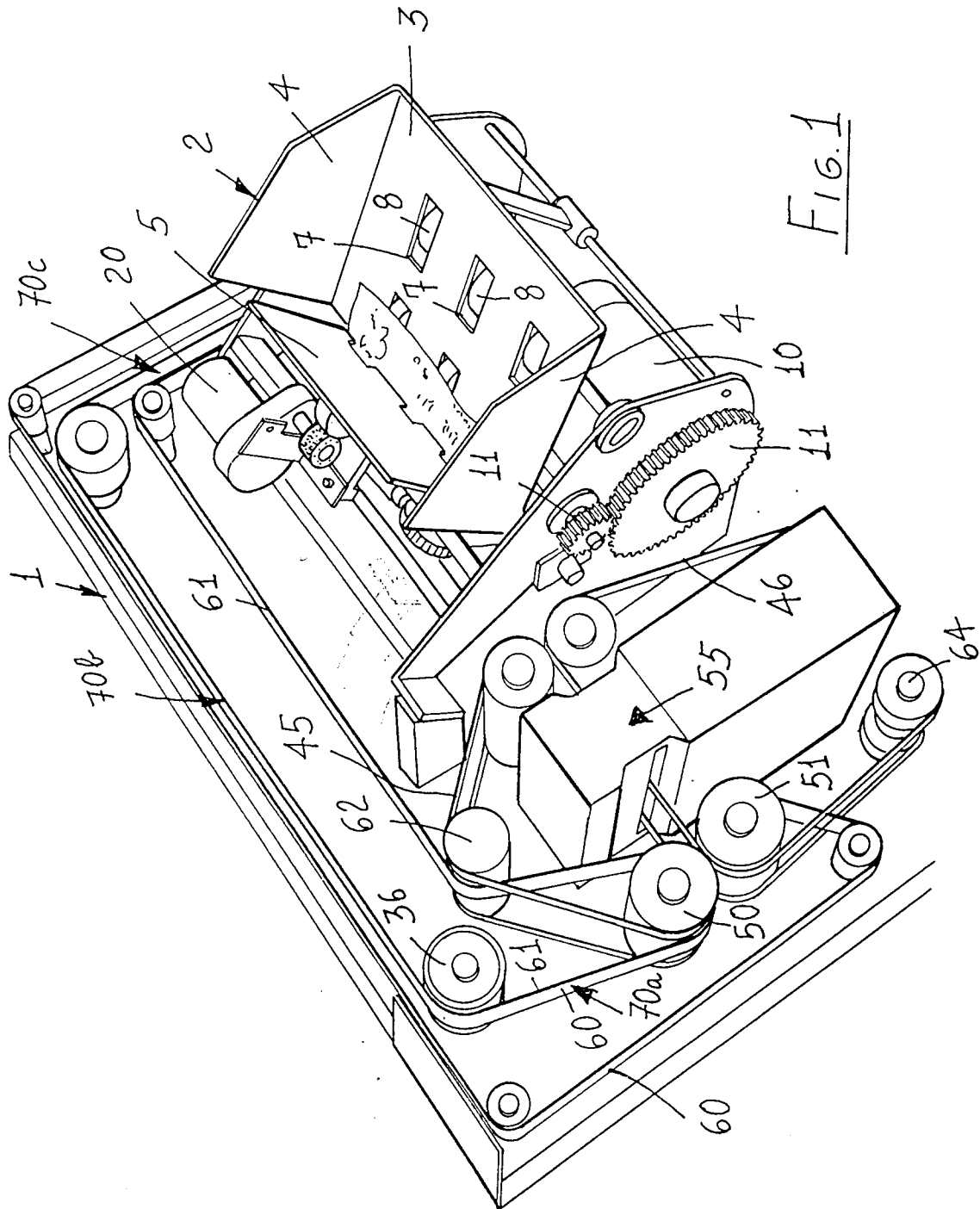

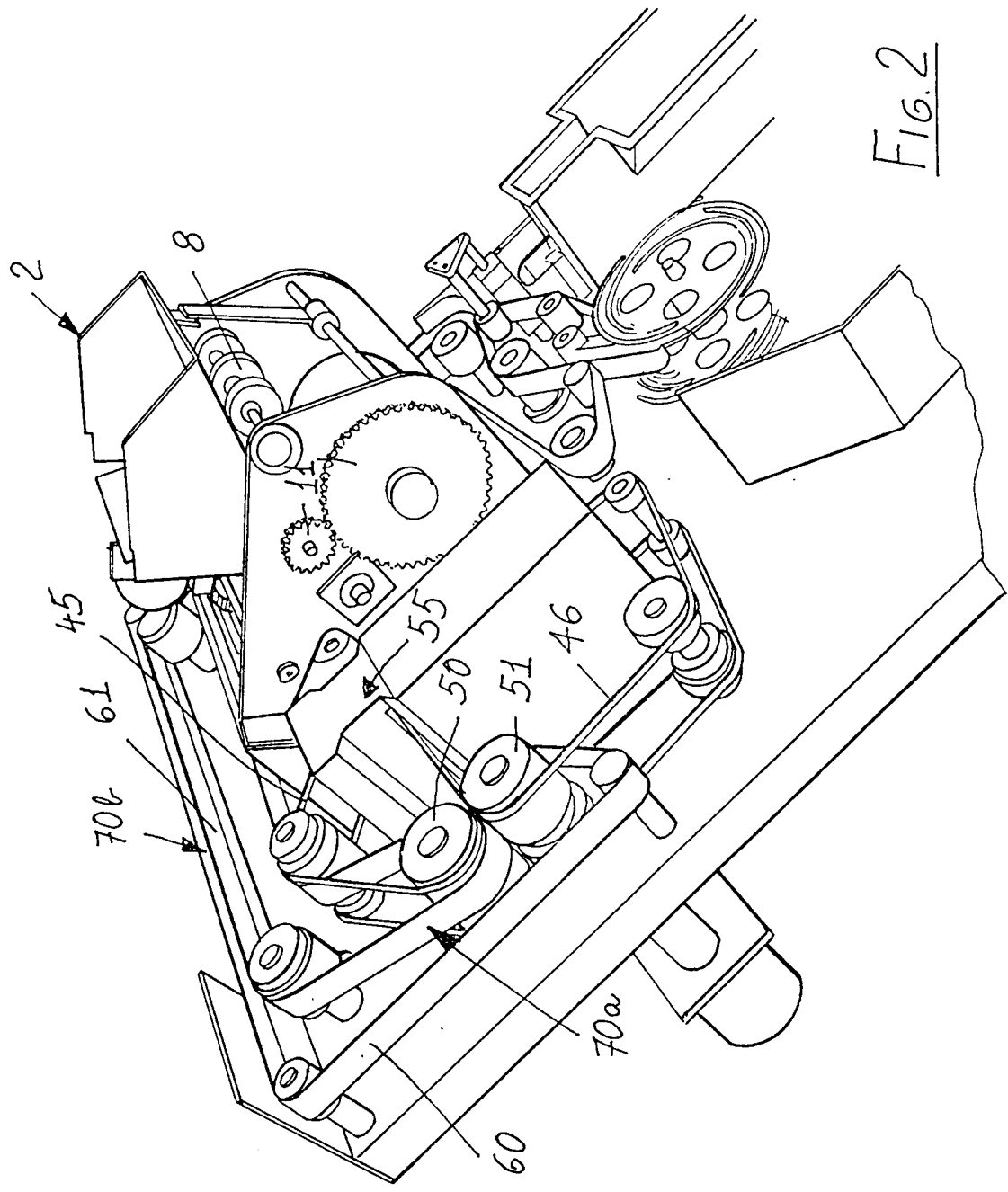

FIG. 2

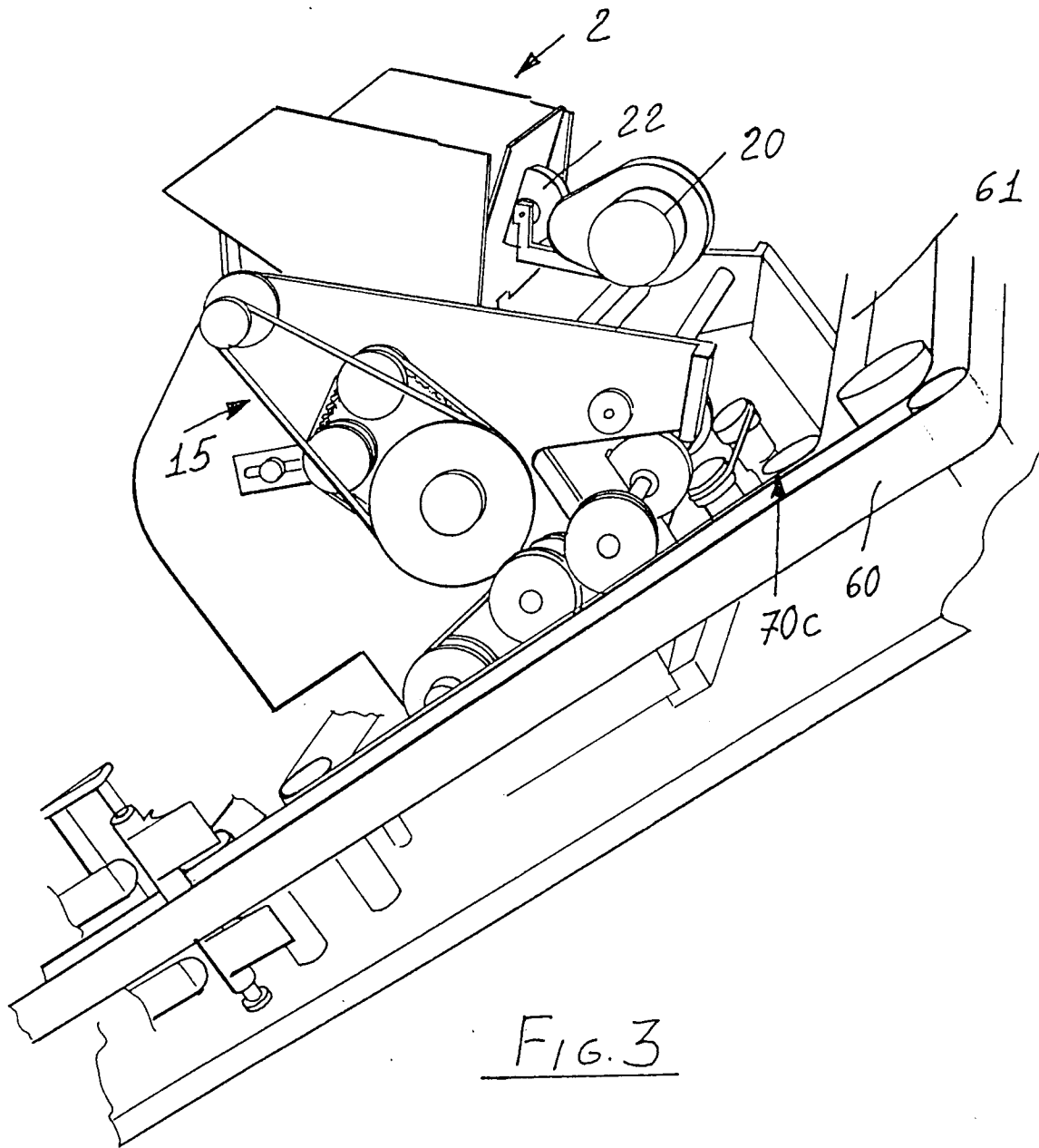

FIG. 3

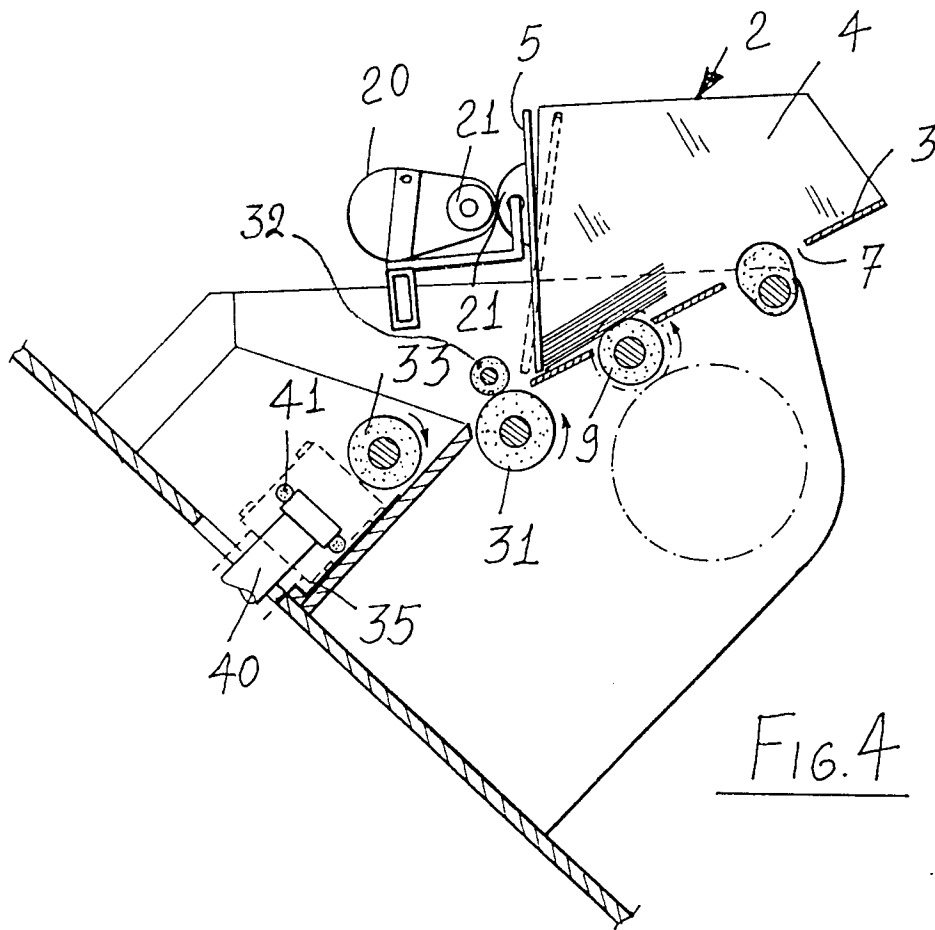

FIG. 4

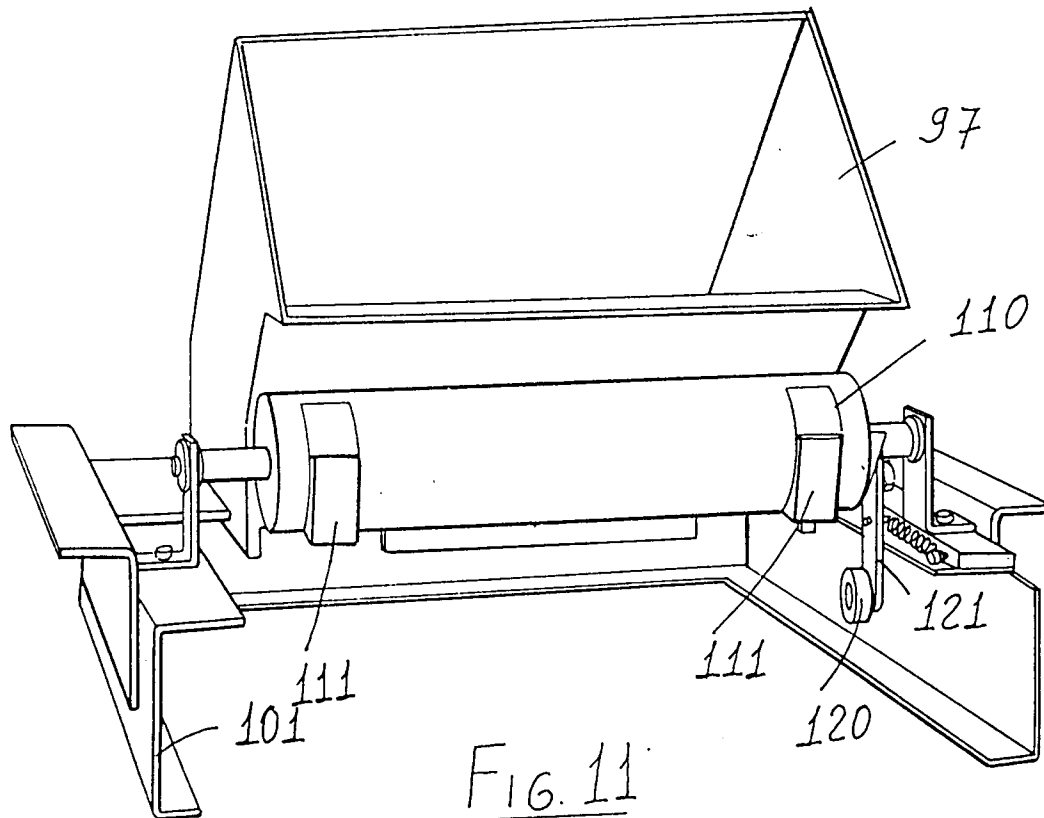
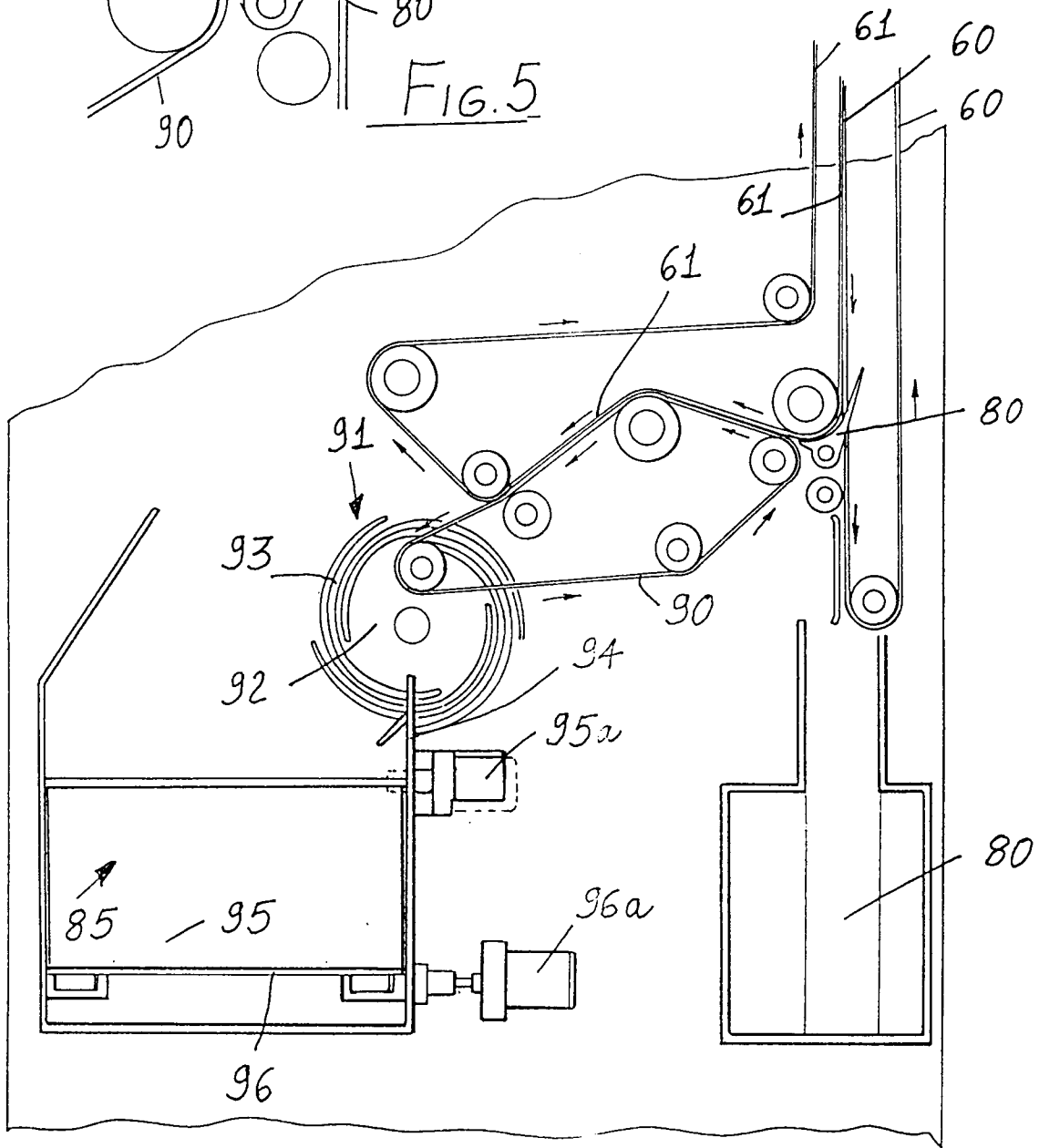
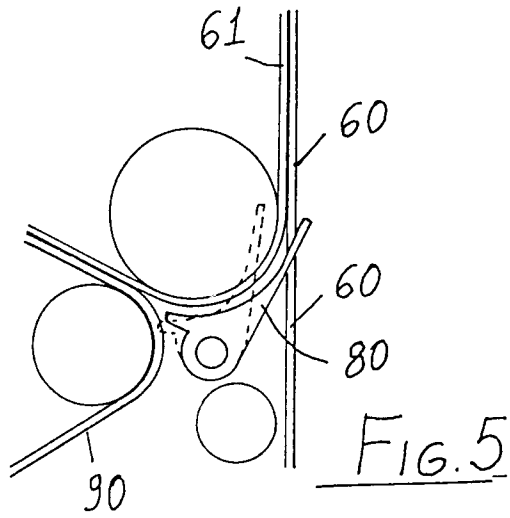

FIG. 11



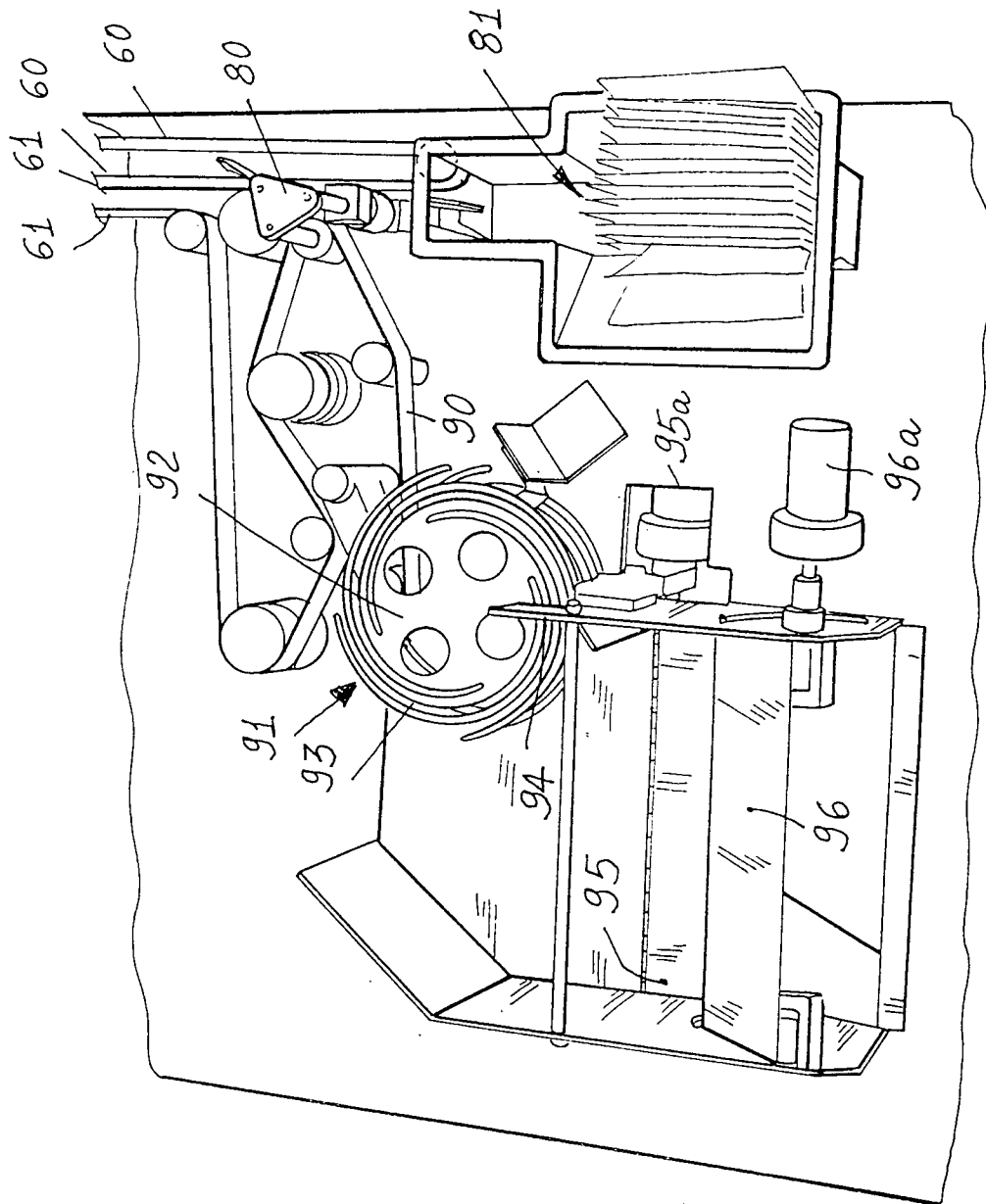

FIG. 7

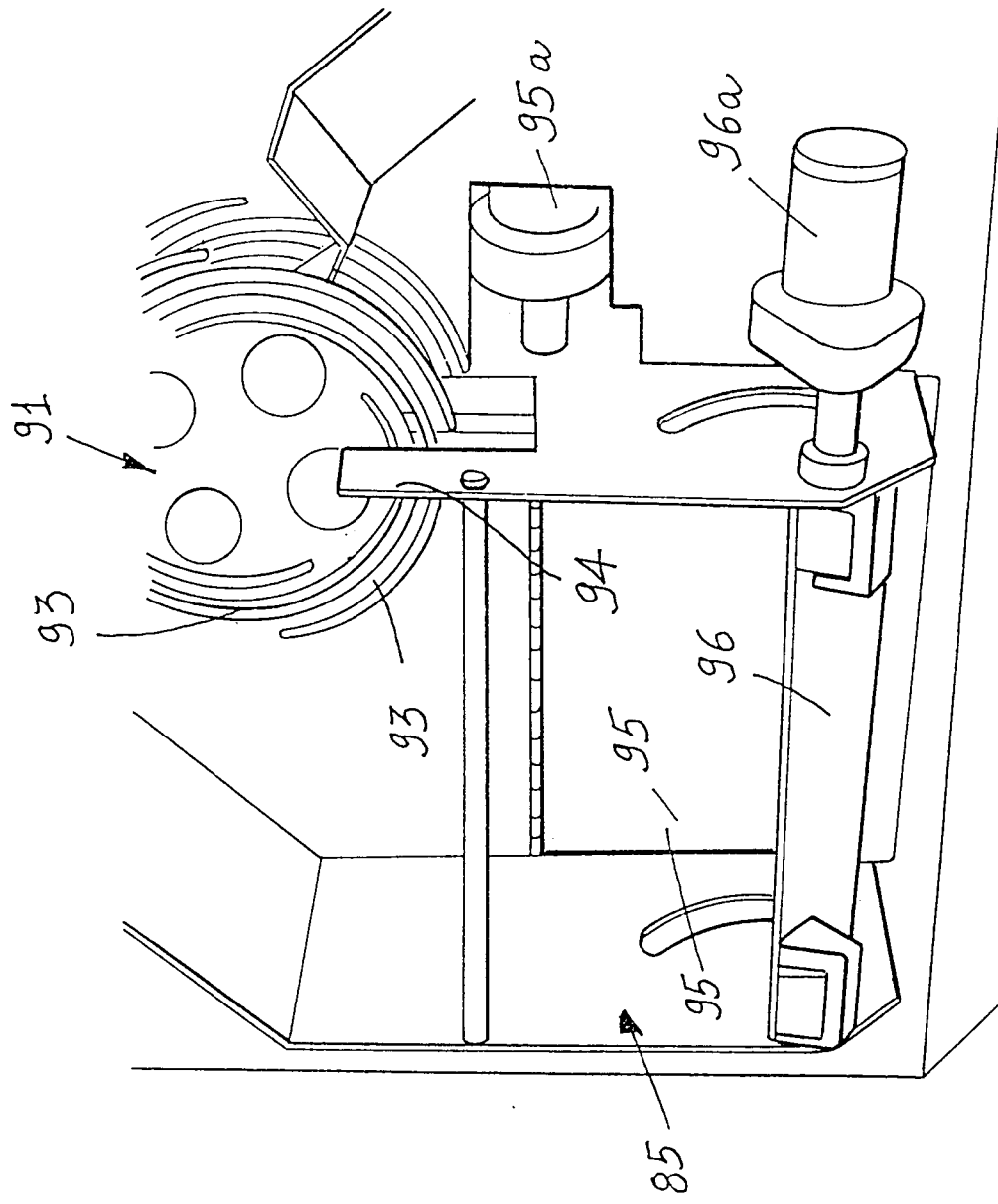

FIG. 8

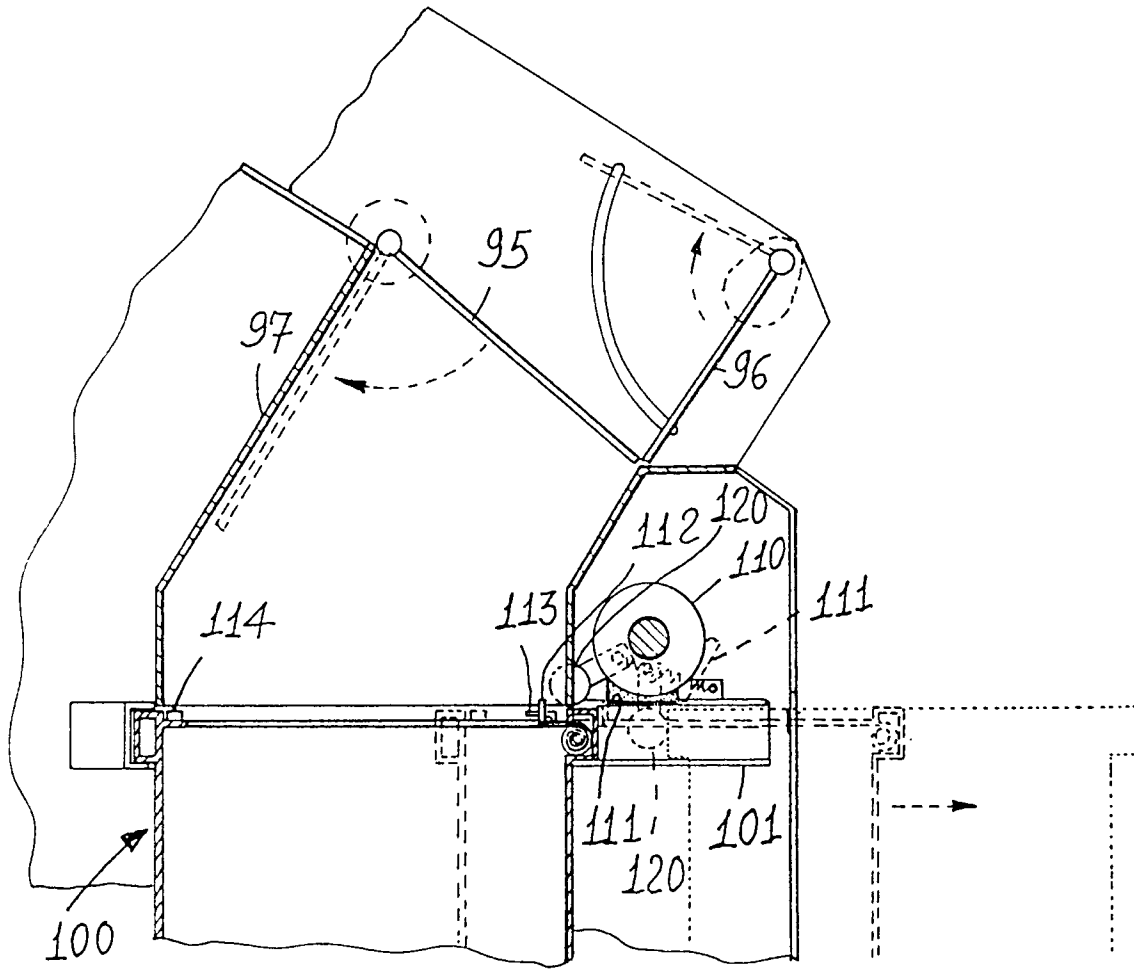

FIG. 9

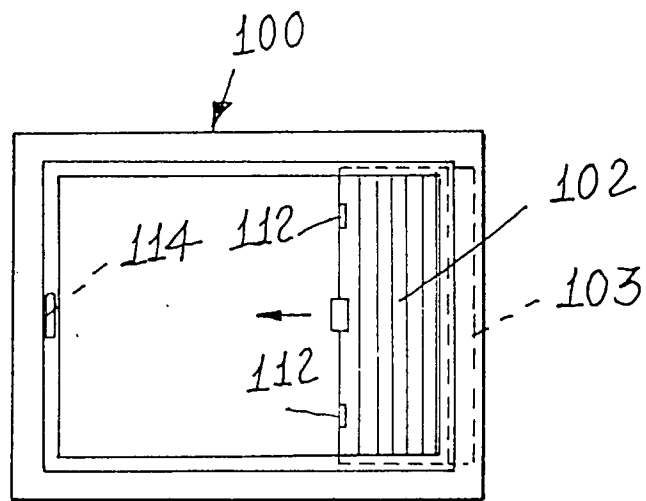

FIG. 10