

19



Europäisches Patentamt
European Patent Office
Office européen des brevets



11 Publication number:

0 563 313 B1

12

EUROPEAN PATENT SPECIFICATION

45 Date of publication of patent specification: **15.02.95** 51 Int. Cl.⁶: **B65H 75/22**

21 Application number: **92904115.0**

22 Date of filing: **11.12.91**

86 International application number:
PCT/US91/09398

87 International publication number:
WO 92/11196 (09.07.92 92/17)

54 **SELECTIVELY WEAKENED CORES FOR CORE WOUND PAPER PRODUCTS.**

30 Priority: **19.12.90 US 629808**

43 Date of publication of application:
06.10.93 Bulletin 93/40

45 Publication of the grant of the patent:
15.02.95 Bulletin 95/07

84 Designated Contracting States:
AT BE CH DE DK ES FR GB GR IT LI LU NL SE

56 References cited:
GB-A- 2 185 959
US-A- 1 005 787
US-A- 4 886 167
US-A- 4 909 388

73 Proprietor: **THE PROCTER & GAMBLE COMPANY**
One Procter & Gamble Plaza
Cincinnati
Ohio 45202 (US)

72 Inventor: **DEARWESTER, Donald David**
10125 Spiritknoll Lane,
Cincinnati, OHIO 45252, Hamilton County,
(US)
Inventor: **NEWBY, Stephen Kreg**
7729 Parktown Drive
West Chester, OH 45069 (US)
Inventor: **SWANSON, James Lee**
10152 Andalusia Close
Cincinnati, OH 45241 (US)

74 Representative: **Bottema, Johan Jan et al**
Procter & Gamble GmbH
Patent Department
Sulzbacher Strasse 40-50
D-65824 Schwalbach am Taunus (DE)

EP 0 563 313 B1

Note: Within nine months from the publication of the mention of the grant of the European patent, any person may give notice to the European Patent Office of opposition to the European patent granted. Notice of opposition shall be filed in a written reasoned statement. It shall not be deemed to have been filed until the opposition fee has been paid (Art. 99(1) European patent convention).

Description

This invention relates to a core for core wound products, particularly to a core which has been flattened or compressed to minimize its void space, and more particularly to a flattened core having a means for rerounding the core to more nearly its original condition.

BACKGROUND OF THE INVENTION

Core wound paper products, such as toilet tissue and paper towels, are well known in the art and are highly useful consumer products. Such products comprise a core about which layers of the paper product are wound. The core may be, and frequently is, inserted onto a spindle for convenient temporary storage of the paper product and for removal of the paper product from the core and from the balance of the roll on demand. The spindle is inserted through the center of the core and, thus, requires the core to be open, so that the spindle may fit therethrough without encountering excessive friction or later causing difficulty in the dispensation of the desired paper product.

A preferred core shape is a cylinder having a geometrically round cross-section, so that the core (and the paper product wound thereon) freely rotates about the axis of the spindle and the paper product is easily removed from the roll. One improvement to rolls of core wound paper products is compression of the core, in a direction normal to the axis of the core, to reduce the void space in the core. This arrangement provides for convenient storage, handling and shipment of core wound paper products, due to the products may be stored and shipped more economically and in higher densities.

Several attempts have been made in the art to capitalize on the benefits of compressed core wound paper products. For example, U.S. Patent 4,762,061 issued August 9, 1988, to Watanabe et al. and U. S. Patent 4,909,388 issued March 20, 1990, to Watanabe disclose rolls of paper product compressed to one-half to one-fifth of the original diameter of the product. The cores of these products are taught to be provided with a slight elasticity to allow the cores to return from the flattened shapes, attained under compression, to the original cylindrical shape. It is generally desired, per these patents, that the flattened rolls be easily returned to their original shape.

U.S. Patent 1,005,787 issued October 1911 to Sibley discloses a flattened toilet paper package wound onto a hollow core made of flexible and axially corrugated paper stock. The corrugated core holds the fabric and results in an oscillatory motion as the paper is removed from the roll. GB Patent Specification 709,363 published May 19, 1954, to Samson discloses a web of paper or pliable sheet material wound upon a core which is diametrically flattened and is said to readily resume its tubular shape when the roll is unpacked. The core consists of spirally wound strips of kraft sheet material and is flexible. The flexibility is said to permit the core to be flattened without cracking and to later recover its cylindrical shape after flattening.

U.S. Patent 4,886,167 issued December 12, 1989, to Dearwester discloses unilaterally compressed toilet tissue having flattened cores comprising the features appearing in the pre-characterising part of claim 1, with little to no void space illustrated between the diametrically opposed faces of the flattened core cross-section. The Dearwester patent is incorporated herein by reference for the purpose of showing particularly preferred compact, compressed rolls of toilet tissue and paper towels.

The foregoing teachings suffer from the drawback that upon rerounding, diametrically opposed creases frequently occur throughout the core and prevent the desired cylindrical shape from being obtained. These creases frequently cause the core to fit poorly on a spindle, and thereby, results in an inconvenience to the user each time such a core is inserted onto, used while on, or removed from a spindle. Furthermore, the non-round cross-section of such a core may prevent easy removal of the paper product from the remainder of the roll, resulting in further inconvenience to the user each time a sheet or a larger portion of the paper product is desired. A core having a nonround cross section is also typically noisier during dispensing.

One attempt to overcome the problems associated with core flattening is to prevent such flattening, as disclosed in U.S. Patent 2,659,543 issued November 17, 1953, to Guyer, which patent suggests a way to maintain the original core shape. This patent teaches a core for tape products having at least one axially oriented groove or slot disposed along the outside of the core at uniform intervals around its circumference. When material is tightly wound onto the core, the grooves slightly collapse, providing relief of the compressive hoop stress induced by tight winding of the tape about the core. However, this teaching suffers from the drawback that the round cross-section of the core is maintained and the aforementioned advantages of a flattened core are lost.

What is needed, therefore, is a core which can be flattened as taught in the prior art, but more conveniently and accurately rerounded after the compressive stresses applied to the paper product are removed.

Accordingly, the subject of this invention to provide a core having a means for flattening and rerounding the core in a manner more convenient to the user and which will precisely and repeatedly cause the core to more nearly resume its original shape.

5 BRIEF SUMMARY OF THE INVENTION

The present invention comprises a flattened core about which a core wound paper product is wound to comprise a roll of the paper product. The flattened core has an inner circumference, an outer circum-
10 ference, and two oppositely disposed ends defining a longitudinal axis. The flattened core is capable of approximating a circular cross section, upon rerounding. The core further comprises at least one axially oriented means for weakening the resistance of the core to applied compressive forces. The weakening means is disposed on at least one of the inner circumference, the outer circumference, or may intercept both the inner and outer circumferences by being through the entire thickness of the core.

In one embodiment, the weakening means comprises a plurality of axially oriented continuous score
15 lines. In a second embodiment, the weakening means comprises a plurality of axially oriented perforations. In a third embodiment, the weakening means comprises a plurality of axially oriented holes. The score lines, perforations, or holes may either be blind - so that only one circumference of the core is affected by the weakening means or may pass through the entire thickness of the core to intercept both the inner and outer circumferences of the core.

20

BRIEF DESCRIPTION OF THE DRAWINGS

While the Specification concludes with claims particularly pointing out and distinctly claiming the
25 present invention, it is believed the same will be better understood from the following Specification taken in conjunction with the associated drawings wherein like parts are given the same reference numeral, and:

- Figure 1 is a perspective view of a flattened core and paper product according to the present invention;
- Figure 2 is a perspective view of a core according to the present invention prior to flattening, and having a plurality of various types of axially oriented score lines disposed about the inner and outer circum-
30 ferences of the core;
- Figure 3 is a schematic plan view of a core according to the present invention when unfolded, and having five circumferentially spaced axially offset holes;
- Figure 4 is a schematic plan view of a core according to the present invention when unfolded, and having five circumferentially spaced holes inset from each end;
- Figure 5 is a schematic plan view of a core according to the present invention when unfolded, and
35 having five lines of equally sized cuts and lands extending inwardly about one inch from each end of the core;
- Figure 6 is a schematic plan view of a core according to the present invention when unfolded, and having five lines of equally sized cuts and lands penetrating only about one half the thickness of the core;
- 40 Figure 7 is a schematic plan view of a core according to the present invention when unfolded, and having five lines of perforations with cuts one-third the length of the lands;
- Figure 8 is a schematic plan view of a core according to the present invention when unfolded, and having five lines of cuts terminating before intercepting either end of the core;
- Figure 9 is a schematic plan view of a core according to the present invention when unfolded, and
45 having five lines of cuts and lands, larger than those of either Figures 6 or 7;
- Figure 10 is a schematic plan view of a core according to the present invention when unfolded, and having five lines of equally sized cuts and lands smaller than those of the preceding figures; and
- Figure 11 is a schematic plan view of a core according to the present invention when unfolded, and having five lines of alternately spaced cuts and lands with the cuts three times the size of the lands.

50

DETAILED DESCRIPTION OF THE INVENTION

As illustrated in Figure 1 and as used herein, a "core" refers to a hollow tubular member about which
55 another component is wound in a spiral for later dispensing and removal. As used herein, a "paper product" refers to a cellulosic base product wound onto the core 20 and is removed, typically, in batch form, i.e., one or more sheets at a time, for usage and eventual discard. Used paper product 24, when taken from the core 20, is not returned. As used herein a "roll" refers to the aggregation of a "core" and a "paper product" wound thereon. The roll 28 may further comprise a wrapping 32 to maintain the configuration illustrated by

Figure 1.

A core 20, according to the present invention, may advantageously be used for toilet tissue or for paper towels. The core 20 is generally cylindrical prior to compression and flattening, has an axial length defined by two oppositely disposed ends. The ends of the core 20 are circular in cross section prior to flattening.
 5 The line connecting the centers of these circles is the "longitudinal axis" of the core 20. As used herein "axial" refers to the longitudinal axis.

When toilet tissue is wound on the core 20, the resulting roll 28 of toilet tissue typically has a diameter of about 10.2 centimeters to about 12.7 centimeters (4.00 to 5.00 inches) and a length of about 11.4 centimeters (4.50 inches) between the ends. If a core 20 embodying the present invention is used for paper
 10 towels, the roll 28 of paper towels typically has a diameter of about 10.2 to about 15.2 centimeters (4.00 to 6.00 inches) and a length of about 27.9 centimeters (11.0 inches) for the embodiments described herein.

The typical core 20 may be made of two layers of a paper having any suitable combination of bleached krafts, sulfites, hardwoods, softwoods, and recycled fibers. The core 20 should exhibit uniform strength without weak spots. Preferably, the core 20 is not calendered, so that it is relatively stiff and retains
 15 adhesive deposited thereon. The core 20 should have a mullen strength of at least 60 and preferably at least 70 as measured according to ASTM Test Method D2529. The core 20 may have a thickness of about 0.5 millimeters (0.020 inch). The core 20 should be free of objectionable odor and impurities or contaminants which may cause irritation to the skin.

The core 20 may be made of paper having a basis weight of about 0.16 kilograms per square meter
 20 (0.032 pounds per square foot) and a ring crush strength of at least 6.79 kilograms per centimeter (38 pounds per inch) and preferably at least 8.93 kilograms per centimeter (50 pounds per inch) as measured according to Tappi Standard T818 OM--87.

The core 20 according to the present invention is provided with at least one means 36 for selectively
 25 weakening the resistance of the core 20 to compressive forces, and more particularly to diametrically applied compressive forces. The diametrically applied compressive forces may occur at any point along, or throughout the entire axis of, the core 20.

As used herein, "diametrically applied compressive forces" refer to opposed compressive forces applied at any diameter of any cross section of the core 20. It is, of course, to be recognized that compressive forces may be applied along a chord of the cross section and not be coincident a diameter.
 30 However, the principles involved in such application are substantially similar to those of diametrically applied compressive forces and, will not be further distinguished or repeated.

Upon application of the compressive forces, the core 20 will collapse into the flattened condition of
 35 Figure 1. The cross section of the flattened core 20 of Figure 1 has a major axis a-a, and a mutually orthogonal minor axis i-i. The major axis a-a and minor axis i-i of the cross section are transverse and orthogonal the longitudinal axis of the core 20. The major axis a-a is aligned with the longest dimension of the cross section of the paper product 24 when flattened, and the minor axis i-i is the perpendicular bisector thereto.

It has been found that at least one circumferentially disposed means 36 for weakening the resistance of
 40 the core 20 to applied compressive forces is required. Preferably, but not necessarily, each means 36 for weakening the resistance of the core 20 to applied compressive forces is equally circumferentially spaced from the adjacent means 36 for weakening the resistance of the core 20 to applied compressive forces, so that the cross section of the core 20 more nearly approaches a circle than an irregular polygon upon rerounding.

The azimuthal orientation of the major and minor axes a-a and i-i of the flattened core 20 can be
 45 predetermined by the circumferential disposition and spacing of the means 36 for weakening the resistance of the core 20 to applied compressive forces. If the core 20 is provided with two diametrically opposed means 36 for weakening the resistance of the core 20 to applied compressive forces, and if the diameter along which the compressive forces are applied is about 90° relative to the two means 36 for weakening the resistance of the core 20 to applied compressive forces, the core 20 will generally flatten at the two
 50 means 36 for weakening the resistance of the core 20 to applied compressive forces.

The resulting flattened core 20 will have a major axis a-a with two vertices, one located at each end of
 the major axis a-a and corresponding to the means 36 for weakening the resistance of the core 20 to applied compressive forces. Therefore, preferably, an even number of means 36 for weakening the resistance of the core 20 to applied compressive forces is provided, so that each means 36 for weakening
 55 the resistance of the core 20 to applied compressive forces is diametrically opposed to another means 36 for weakening the resistance of the core 20 to applied compressive forces.

However, upon rerounding the core 20 will not approximate its original cylindrical shape, due to the two vertices maintain the cross section of the core 20 in a somewhat doubly convex shape. Additional

circumferentially disposed means 36 for weakening the resistance of the core 20 to applied compressive forces are needed to provide additional vertices. Upon rerounding, the core 20 will assume a polygonal cross section, corresponding in number of sides to the number of vertices, each vertex corresponding to a particular individual means 36 for weakening the resistance of the core 20 to applied compressive forces.

5 As noted above, at least one, and even a plurality of two means 36 for weakening the resistance of the core 20 to applied compressive forces is inadequate due to the resulting doubly convex shape upon attempted rerounding. If four means 36 for weakening the resistance of the core 20 to applied compressive forces are provided, the core 20 rerounds to a generally square cross section and has a hollow hexahedronal shape. Such a core 20, when attempted to be rerounded, suffers from excessive wobble and noise on the spindle and is, therefore, generally not preferred.

10 A core 20 having six means 36 for weakening the resistance of the core 20 to applied compressive forces, each equally circumferentially spaced (on increments of about 60° or a multiple thereof) from the adjacent means 36 for weakening the resistance of the core 20 to applied compressive forces, works well. Two means 36 for weakening the resistance of the core 20 to applied compressive forces occur at each end of the major axis a-a of the core 20 when it is flattened. Two means 36 for weakening the resistance of the core 20 to applied compressive forces are disposed on each side of the flattened core 20, straddling the minor axis i-i and juxtaposed with the two means 36 for weakening the resistance of the core 20 to applied compressive forces on the other side of the flattened core 20. This core 20 rerounds to a hexagonal cross section and exhibits less wobble and noise during dispensing.

15 A core 20 having eight, ten, or twelve equally spaced means 36 for weakening the resistance of the core 20 to applied compressive forces is undesirable due to natural tendency of the core 20 to reform to a quadrilaterally shaped cross section. Also this structure requires two stages of rerounding, further inconveniencing the user.

20 As illustrated in Figure 2, a particularly preferred means 36 for weakening the resistance of the core 20 to applied compressive forces is a continuous axially oriented score line. The score line is preferably parallel to the axis of the core 20, but prophetically may wrap the core 20 in a helical shape, if desired. A means 36 for weakening the resistance of the core 20 to applied compressive forces is considered to be "axially oriented" if a line drawn through the weakening means 36 forms an included angle less than $\pm 45^\circ$ of the longitudinal axis of the core 20.

25 The score lines may be disposed on either the inner or outer circumference of the core 20. It will be apparent, that if a plurality of score lines is provided, the plurality may be divided between the inner and outer circumferences of the core 20.

30 As used herein, "score lines" are inclusive of lines of compression, and, preferably, lines defined by material removed from the core 20. The score lines may be made by a scoring rule or a rotary die and preferably penetrate about 25 percent to about 100 percent of the thickness of the core 20. The score lines preferably extend between and to both ends of the core 20.

35 If desired, the means 36 for weakening the resistance of the core 20 to applied compressive forces, such as a score line, may be continuous, discontinuous or intermittent and may resemble discrete holes or perforations. The discrete holes or perforations may, but need not, extend to each end of the core 20 and may be axially offset from the ends of the core 20.

40 For example, referring to Figures 3-10, in turn, eight nonlimiting examples are provided, illustrating various means 36 for weakening the resistance of the core 20 to applied compressive forces. One sample of each example is tabulated in Table I, to provide for easy comparison of the effect of the parameters listed in Table I on the attempted rerounding.

45 Each row in Table I represents one sample, which was prepared from commercially available Charmin brand toilet tissue made and sold by the Procter & Gamble Company of Cincinnati, Ohio. The cores 20 were removed from the roll 28 of paper product 24, provided with the designated means 36 for weakening the resistance of the core 20 to applied compressive forces, and inserted back into the center of the paper product 24 to complete the roll 28. Each roll 28 of paper product 24 was then diametrically compressed along the minor axis i-i with a force of about 36 kilograms (80 pounds).

50 The rolled paper products 24 were then aged for a period of about four weeks at about 50% relative humidity and 72°F. A minimum two week aging period is considered necessary to allow any memory or resiliency of the core 20 to be developed, so that storage and shipping conditions are approximated and accurate data are obtained when the sample is later rerounded. An aging period of less than about two weeks is considered unsatisfactory, as the results obtained may not approximate that seen in actual practice when the product is made, warehoused, shipped to the point of purchase, purchased, taken to the consumer's home, and finally installed onto a spindle and used.

Each core 20 was made of the aforementioned materials and is about 11.43 centimeters (4.5 inches) in length. The samples of Figures 3-10 were provided with six equally spaced means 36 for weakening the resistance of the core 20 to applied compressive forces, one through-cut for opening the core 20 and five means 36 for weakening the resistance of the core 20 to applied compressive forces as described below.

5 The first column of Table I provides a plan view illustration of the described means 36 for weakening the resistance of the core 20 to applied compressive forces. In the second column of Table I, the five means 36 for weakening the resistance of the core 20 to applied compressive forces are described. However, for these samples the cores 20 had to be slit and opened as illustrated in the plan views of Figures 3-10 to install the described weakening means 36 for a total of six means 36 for selectively
10 weakening the resistance of the core 20 to applied compressive forces.

Whenever five described weakening means 36 were utilized with one continuous through slit, the through slit was reclosed with adhesive tape and the core 20 compressed, so that upon flattening the major axis a-a intercepted the taped slit and one of the described weakening means 36. In practice, the aforementioned through slit would be replaced by a means 36 for weakening the resistance of the core 20
15 to applied compressive forces which is similar to the other five as described, so that all six means 36 for weakening the resistance of the core 20 to applied compressive forces are identical.

The percentage of the perforated or cut surface area listed in the third column of Table I is the percentage of axial linear dimension affected by the means 36 for weakening the resistance of the core 20 to applied compressive forces. Each core 20 had a total linear dimension of about 68.8 centimeters (27.1
20 inches) (6 lines x 4.5 inches). In the fourth column the longitudinal axial distribution of the weakening means 36 is listed as either end-to-end and extending throughout the entire length of the core 20, centered and not intercepting the ends, or endwise and starting at both ends, but not meeting in the center.

The vertex forming effect of the weakening means 36 in the fifth column of Table I was judged to be low ("L"), medium ("M"), or high ("H"), based upon subjective judgment when trying to reround the core 20
25 to its original cylindrical condition. A sample was judged to be low in vertex forming effect if no distinct vertices were observed upon rerounding. A sample was judged to be medium in vertex forming effect if a change in the direction of curvature was apparent at one or more of the vertices. A sample was judged to be high in vertex forming effect if the vertices formed corners at the means 36 for weakening the resistance of the core 20 to applied compressive forces.

30 The sample of Figure 3 was provided with five holes, approximately 6.4 millimeters diameter (0.25 inches). Each hole is axially offset from the circumferentially adjacent hole by approximately one-fifth of the length of the core 20.

The sample of Figure 4 was provided with ten circumferentially spaced holes having a diameter of approximately 6.4 mm (0.25 inch), five at each end of the core 20. Each of the five holes was in the same
35 plane, and inset approximately 2.54 cm (one inch) inward from the end of the core 20. The five holes at each end of the core 20 were axially aligned with the mutually opposite five holes at the other end of the core 20.

The sample of Figure 5 was perforated from each end towards the center of the core 20 with alternating one millimeter (0.04 inches) cuts 36 and one millimeter (0.04 inch) lands. The perforations extended
40 inwardly about 2.54 centimeters (1 inch) from each end of the core 20.

The sample of Figure 6 was perforated with alternating one millimeter (0.04 inch) cuts 36 and one millimeter (0.04 inch) lands. The cuts 36 are made from the inside circumference through one half the thickness of the core 20. The percentage of effective surface area for Figure 6 was halved, to account for
45 the fact that the perforation only affects one half of the total thickness of the core 20.

The sample of Figure 7 was perforated with alternating two millimeter (0.08 inch) cuts 36 and six millimeter (0.24 inch) lands. The cuts 36 and lands extend throughout the entire length of the core 20.

The sample of Figure 8 was provided with double cuts 36 about 2.54 centimeters (1.0 inch) in length. The cuts 36 were axially terminated about 1.27 centimeters (0.5 inch) inwardly from each end.

50 The sample of Figure 9 was perforated with alternating 9.6 millimeters (0.38 inch) cuts 36 and 9.6 millimeters (0.38 inch) lands. The perforations extend entirely from end to end of the core 20.

The sample of Figure 10 was perforated with alternating one millimeter (0.04 inch) cuts 36 and one millimeter (0.04 inch) lands. The perforations extend from end to end of the core 20.

The sample of Figure 11 was provided with alternating three millimeter (0.12 inch) cuts 36 and one millimeter (0.04 inch) lands. The perforations extend from end to end of the core 20.

55

TABLE I

Fig.No.	Description	Percentage of Perforated or Cut Axial Dimension	Axial Distribution of Weakening Means	Vertex Forming Effect
3	6.4 mm (0.25 in.)dia. axially offset holes	6	end-to-end	L
4	Five 6.4 mm (0.25 in.)dia. holes, 2.54 cm (1 in.) in from each end	11	endwise	L
5	1mm cut, 1 mm land extending inwardly 2.54 cm (1 in.) from ea. end	22	endwise	M
6	1mm cut, 1mm land throughout one-half the thickness of the core	25	end-to-end	M
7	2 mm cut, 6 mm land	25	end-to-end	M
8	Double 2.54 cm (1 in.) cuts spaced inwardly 1.27 cm (0.5 in.) from ea. end	44	centered	M
9	9.6 mm (0.38 in.) cut, 9.6 mm (0.38 in.) land	50	end-to-end	H
10	1 mm cut, 1 mm land	50	end-to-end	H
11	3 mm cut, 1 mm land	75	end-to-end	H

As can be seen from Table I, generally as the samples had less than about 20% of the axial dimension effected by the means 36 for weakening the resistance of the core 20 to applied compressive forces, the vertex forming effect was judged to be low. As the percentage of perforated or cut area affected by the means 36 for weakening the resistance of the core 20 to applied compressive forces approaches 20% to 45%, the vertex forming effect was judged to be medium, relative to the other samples. As the percentage of perforated or cut area effected by the means 36 for weakening the resistance of the core 20 to applied compressive forces increases above 50%, the vertex forming effect was judged to be high. However, all samples were placed on a spindle and then dispensed. All samples were judged to be superior to a control sample (having no means 36 for weakening the resistance of the core 20 to applied compressive forces) in both noise and in smooth, uninterrupted dispensing.

Claims

1. A flattened core (20) about which a paper product may be wound, and having an inner surface, an outer surface, and two oppositely disposed ends defining a longitudinal axis, said flattened core being capable of approximating a tubular cross-section, characterised in that the core comprises an axially oriented means (36) for weakening the resistance of said core to applied radially compressive forces, said weakening means (36) being disposed on at least one of said inner surface and said outer surface of said flattened core (20) and locally reducing or perforating the crosssectional thickness of the core.
2. A flattened core (20) according to Claim 1 characterised in that said weakening means (36) comprises a plurality of axially oriented perforations on at least one of said inner surface and said outer surface of said flattened core.
3. A flattened core according to Claim 1 characterised in that said weakening means (36) comprises at least one axially oriented score line disposed along at least one of said inner surface and said outer surface of said flattened core.
4. A flattened core (20) according to Claim 1 characterised in that said weakening means (36) comprises a plurality of holes, said holes being distributed in a plurality of axially oriented lines.
5. A flattened core (20) according to Claim 3 characterised in that said at least one score line is substantially continuous and disposed along said outer surface of said flattened core (20).
6. A flattened core (20) according to Claims 1, 2 or 3 characterised in that said weakening means (36) is oriented at an angle of 0° to 45° from said longitudinal axis.

7. A flattened core (20) according to Claim 6 characterised in that said weakening means (36) is substantially parallel to said longitudinal axis.
8. A flattened core (20) according to Claims 1, 2 or 3 characterised in that the weakening means (36) does not intercept either end of said flattened core.
9. A flattened core according to Claim 3 characterised in that it comprises a plurality of axially oriented score lines (36) which are substantially circumferentially spaced about said longitudinal axis when said core (20) is rerounded to a circular cross section.
10. A flattened core (20) according to Claim 9 characterised in that said plurality of score lines is six.

Patentansprüche

1. Ein abgeflachter Kern (20), um welchen ein Papierprodukt gewunden werden kann und mit einer inneren Oberfläche, einer äußeren Oberfläche und zwei gegenüberliegend angeordneten Enden, welche eine Längsachse definieren, wobei der genannte abgeflachte Kern imstande ist, sich einem rohrförmigen Querschnitt zu nähern, **dadurch gekennzeichnet**, daß der Kern ein axial ausgerichtetes Mittel (36) zum Schwächen des Widerstandes des genannten Kerns gegenüber radial aufgebrachtten zusammendrückenden Kräften umfaßt, wobei das genannte Schwächungsmittel (36) an mindestens einer der genannten inneren Oberfläche und der genannten äußeren Oberfläche des genannten abgeflachten Kerns (20) angeordnet ist und die Querschnittsdicke des Kerns lokal reduziert oder perforiert.
2. Ein abgeflachter Kern (20) nach Anspruch 1, **dadurch gekennzeichnet**, daß das genannte Schwächungsmittel (36) eine Mehrzahl von axial ausgerichteten Perforationen an mindestens einer der genannten inneren Oberfläche und der genannten äußeren Oberfläche des genannten abgeflachten Kerns aufweist.
3. Ein abgeflachter Kern (20) nach Anspruch 1, **dadurch gekennzeichnet**, daß das genannte Schwächungsmittel (36) mindestens eine axial ausgerichtete Kerblinie umfaßt, welche entlang mindestens einer der genannten inneren Oberfläche und der genannten äußeren Oberfläche des genannten abgeflachten Kerns angeordnet ist.
4. Ein abgeflachter Kern (20) nach Anspruch 1, **dadurch gekennzeichnet**, daß das genannte Schwächungsmittel (36) eine Mehrzahl von Löchern umfaßt, wobei die genannten Löcher in einer Mehrzahl von axial ausgerichteten Linien verteilt sind.
5. Ein abgeflachter Kern (20) nach Anspruch 3, **dadurch gekennzeichnet**, daß die genannte mindestens eine Kerblinie im wesentlichen kontinuierlich und entlang der genannten äußeren Oberfläche des genannten abgeflachten Kerns (20) angeordnet ist.
6. Ein abgeflachter Kern (20) nach Anspruch 1, 2 oder 3, **dadurch gekennzeichnet**, daß das genannte Schwächungsmittel (36) in einem Winkel von 0° bis 45° von der genannten Längsachse ausgerichtet ist.
7. Ein abgeflachter Kern (20) nach Anspruch 6, **dadurch gekennzeichnet**, daß das genannte Schwächungsmittel (36) im wesentlichen parallel zur genannten Längsachse ist.
8. Ein abgeflachter Kern (20) nach Anspruch 1, 2 oder 3, **dadurch gekennzeichnet**, daß das Schwächungsmittel (36) kein Ende des genannten abgeflachten Kerns unterbricht.
9. Ein abgeflachter Kern (20) nach Anspruch 3, **dadurch gekennzeichnet**, daß er eine Mehrzahl von axial ausgerichteten Kerblinien (36) umfaßt, welche im wesentlichen am Umfang um die genannte Längsachse beabstandet sind, wenn der genannte Kern (20) zu einem kreisförmigen Querschnitt gerundet ist.

10. Ein abgeflachter Kern (20) nach Anspruch 9, **dadurch gekennzeichnet**, daß die genannte Anzahl von Kerblinien sechs ist.

Revendications

5

1. Mandrin aplati (20) autour duquel un produit en papier peut être enroulé, et comportant une surface interne, une surface externe et deux extrémités disposées de manière opposée définissant un axe longitudinal, ledit mandrin aplati étant capable d'approcher une section transversale tubulaire, caractérisé en ce que le mandrin comprend un moyen axialement orienté (36) pour affaiblir la résistance dudit mandrin vis-à-vis de forces compressives appliquées radialement, ledit moyen d'affaiblissement (36) étant disposé sur au moins une desdites surfaces interne et externe dudit mandrin aplati (20) et réduisant ou perforant localement l'épaisseur en section transversale du mandrin.

10

2. Mandrin aplati (20) selon la revendication 1, caractérisé en ce que ledit moyen d'affaiblissement (36) comprend une pluralité de perforations axialement orientées sur au moins une desdites surfaces interne et externe dudit mandrin aplati.

15

3. Mandrin aplati selon la revendication 1, caractérisé en ce que ledit moyen d'affaiblissement (36) comprend au moins une ligne d'entaille axialement orientée disposée le long d'au moins une desdites surfaces interne et externe dudit mandrin aplati.

20

4. Mandrin aplati (20) selon la revendication 1, caractérisé en ce que ledit moyen d'affaiblissement (36) comprend une pluralité de trous, lesdits trous étant distribués selon une pluralité de lignes orientées axialement.

25

5. Mandrin aplati (20) selon la revendication 3, caractérisé en ce que ladite au moins une ligne d'entaille est pratiquement continue et disposée le long de la surface extérieure dudit mandrin aplati (20).

6. Mandrin aplati (20) selon la revendication 1, 2 ou 3, caractérisé en ce que ledit moyen d'affaiblissement (36) est orienté à un angle de 0° à 45° par rapport audit axe longitudinal.

30

7. Mandrin aplati (20) selon la revendication 6 caractérisé en ce que ledit moyen d'affaiblissement (36) est pratiquement parallèle audit axe longitudinal.

8. Mandrin aplati (20) selon la revendication 1, 2 ou 3, caractérisé en ce que le moyen d'affaiblissement (36) ne coupe aucune des extrémités dudit mandrin aplati.

35

9. Mandrin aplati selon la revendication 3, caractérisé en ce qu'il comprend une pluralité de lignes d'entaille axialement orientées (36) qui sont espacées pratiquement circonférentiellement autour dudit axe longitudinal lorsque ledit mandrin (20) est retourné à une section transversale circulaire.

40

10. Mandrin aplati (20) selon la revendication 9, caractérisé en ce que ladite pluralité de lignes d'entaille est d'un nombre de six.

45

50

55

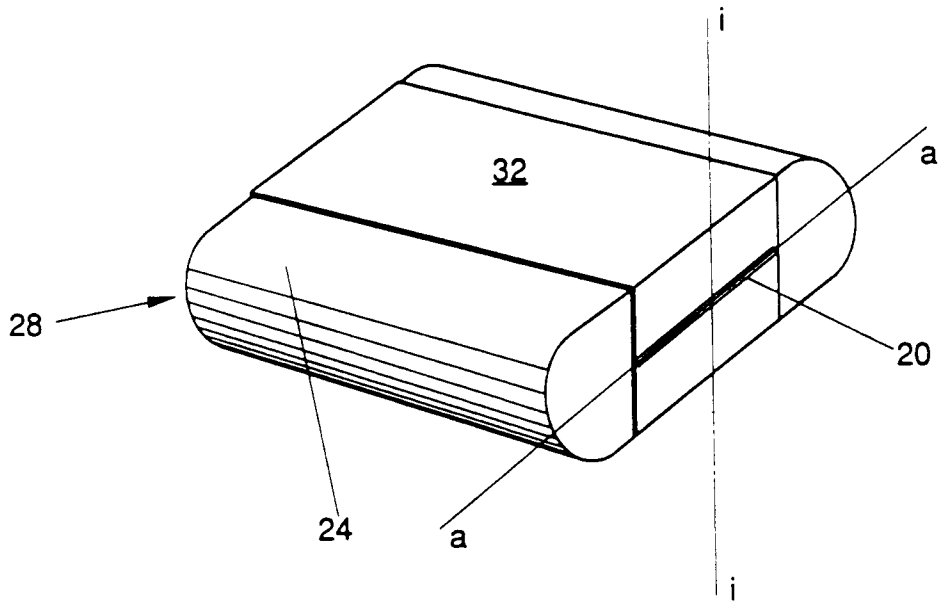

Fig. 1

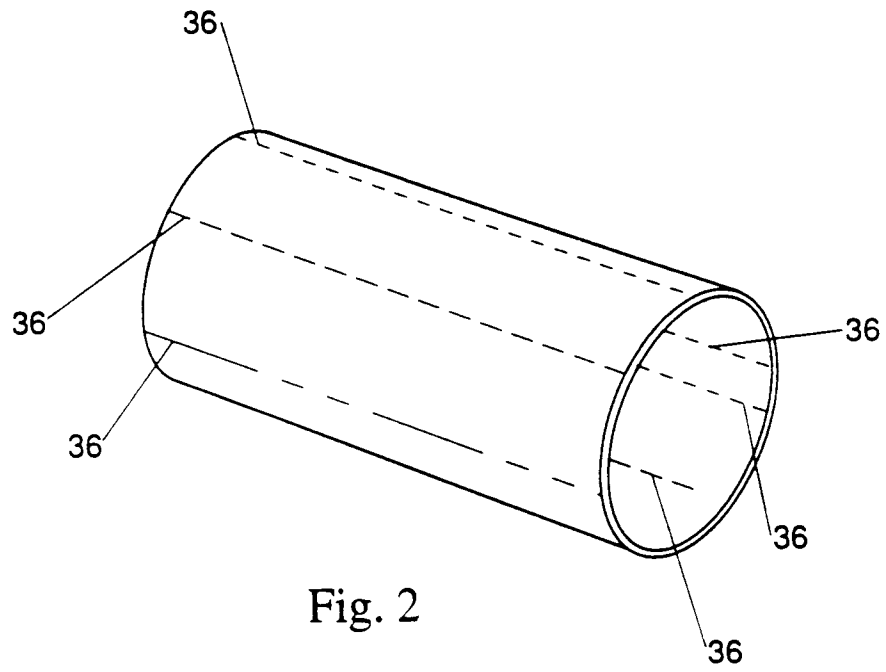

Fig. 2

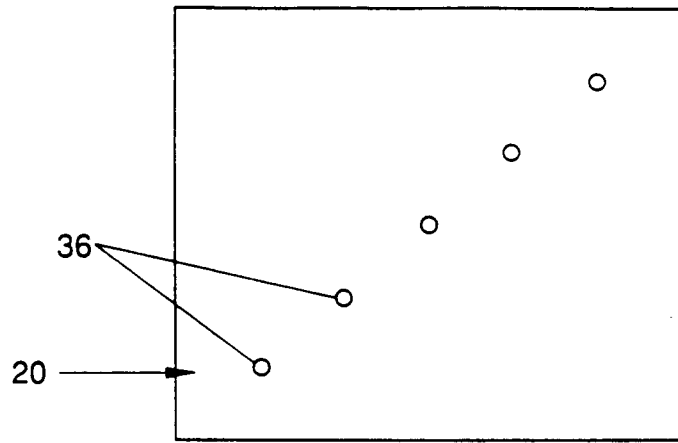

Fig. 3

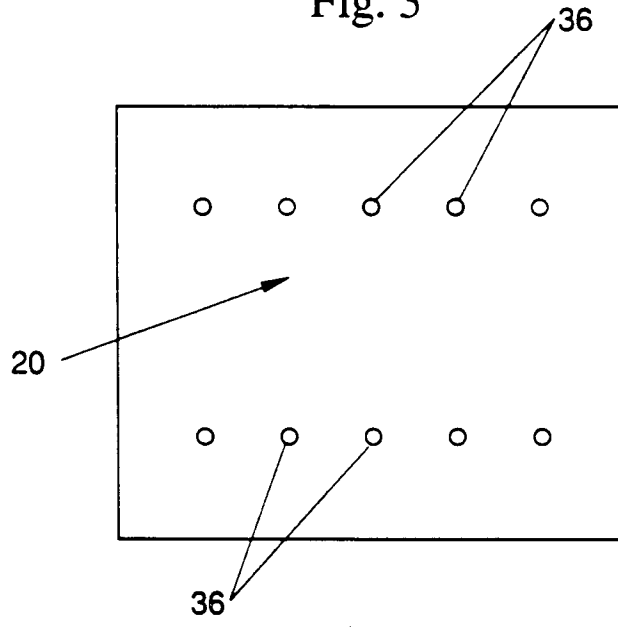

Fig. 4

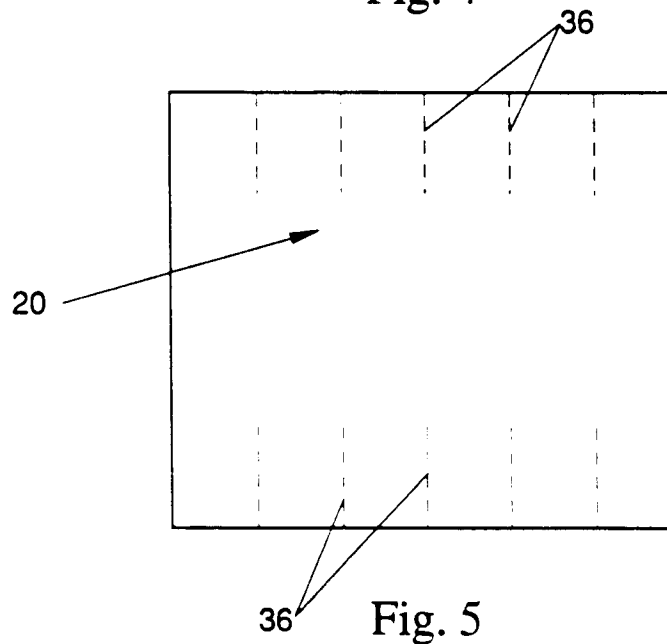

Fig. 5

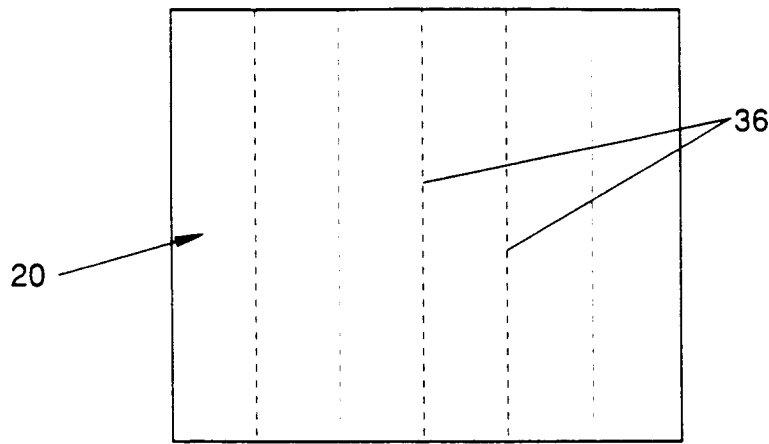

Fig. 6

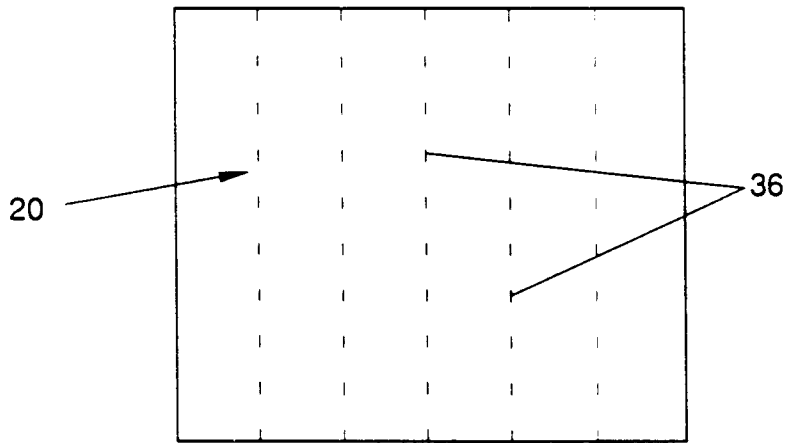

Fig. 7

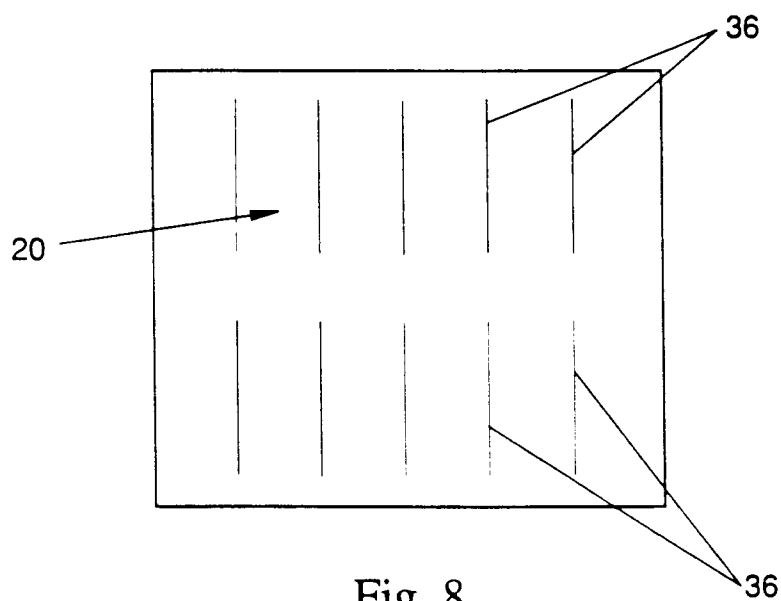

Fig. 8

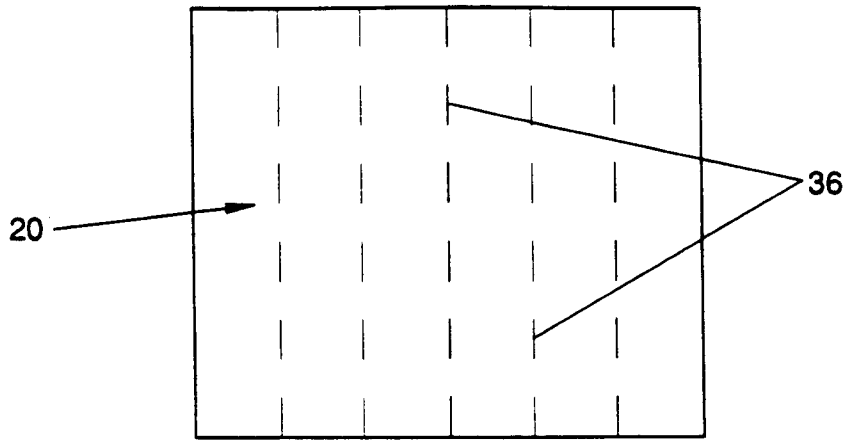

Fig. 9

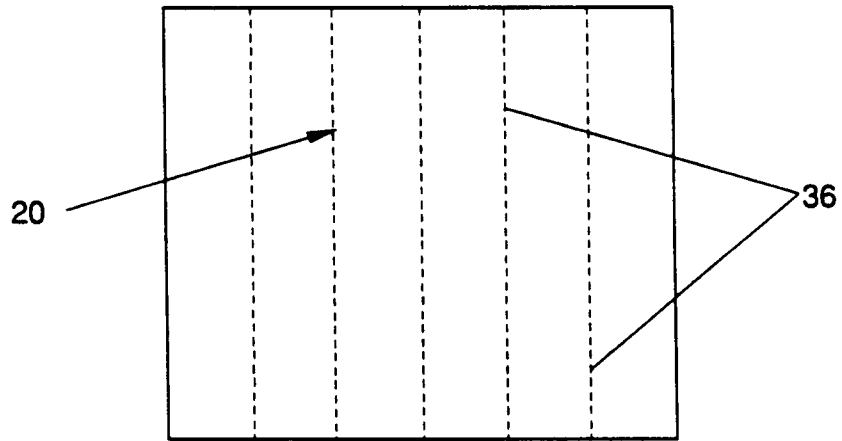

Fig. 10

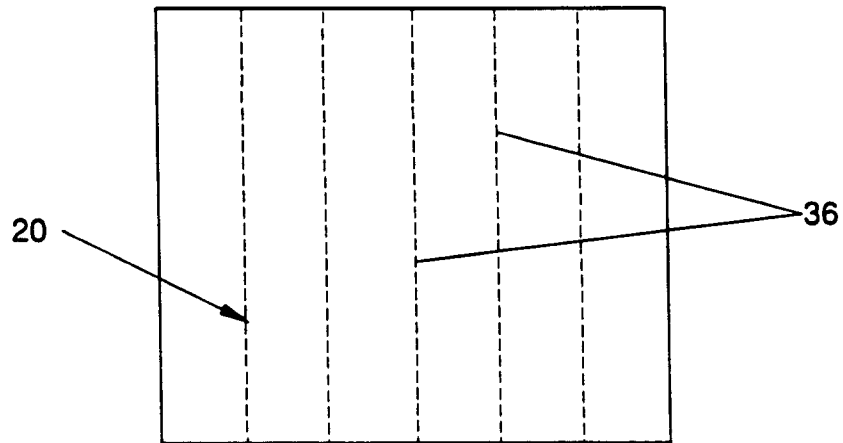

Fig. 11