



Europäisches Patentamt
 European Patent Office
 Office européen des brevets



Publication number: **0 563 495 A1**

EUROPEAN PATENT APPLICATION

Application number: **92500124.0**

Int. Cl.⁵: **A61G 12/00**

Date of filing: **01.10.92**

Priority: **31.03.92 ES 9201017**

Applicant: **ORNALUX S.A.**
Calle Metalurgia, 3
E-33211 Gijon (Asturias)(ES)

Date of publication of application:
06.10.93 Bulletin 93/40

Inventor: **Olabarri Bustillo, Francisco Javier**
Avda. de Castilla, 27-50A
Gijon (Asturias)(ES)

Designated Contracting States:
AT BE CH DE DK FR GB GR IE IT LI LU MC NL
PT SE

Representative: **Gomez-Acebo y Pombo, José Miguel**
c/o CLARKE, MODET & Co.,
Avda. de los Encuartes, 4
E-28760 Tres Cantos, Madrid (ES)

Multifunctional module for doctors.

Multifunctional module for medical services, specially devised to be installed in zones or areas dedicated to medical care and/or treatment, featuring a chamber (1), which is an inverted isosceles trapezoid set up horizontally and composed of four longitudinal profiles (3, 4, 5) and two closing end lids (2), which comprise the chamber (1), and two exterior rigidity profiles (9), showing the intermediate upper and lower profiles (15, 16, and 17, 18) so as to provide lighting, direct and indirect, the chamber (1) is divided by two walls (12) into three sections, each of which is devised for receiving through columns (19, 20) the different services necessary such as gas supply, control devices, electric power, etc.

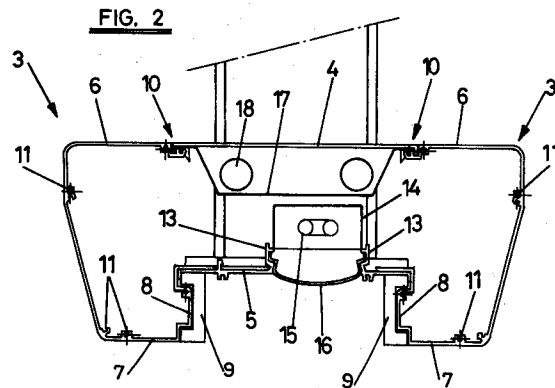

EP 0 563 495 A1

This invention refers to a multifunctional module for medical services, specially conceived to be installed in Zones or areas dedicated to medical care and/or treatment, where it is necessary to have available a supply of certain gases, power, communications, etc.

This, for example, is the case of intensive care units, where it is necessary to have available connections to all types of services which may be necessary at a given time for the care and attention of patients in different situations and conditions.

The module is devised for easy assembly and can be adapted to different sizes and needs.

Besides, the module allows to have available in separate areas the connectors for such services whose proximity could entail a safety risk.

The module object of the invention has a characteristic feature, which is a horizontal tubular chamber. Its approximate shape is that of an inverted isosceles trapezoid composed of longitudinal profiles which can be joined and set among themselves, complemented and assembled by means of locking end lids.

The chamber is subdivided through longitudinal walls, into three independent sections or zones, each of which has intakes for the different services which are supplied through independent upper columns.

The end sections of the chamber are reserved for the supply of different gases, while the central section includes devices for control, connections and for transmission and electrical circuits, as well as lighting elements.

The different profiles which comprise the module are designed so that they combine into a rigid compact set. The tubular chamber can be composed by four longitudinal locking profiles and two external profiles for rigidity. The locking profiles include two end and two intermediate ones which connect and limit the chamber contour.

The two longitudinal profiles have symmetric sections, approximately G-shaped, to define the slanting sides and adjacent sections of the bases in the chamber section. The intermediate longitudinal profiles are flat shaped to define the locking lids to be assembled between the coplanar edges of the end profiles. Lastly, external profiles for rigidity longitudinally embrace the connection area between the longitudinal profiles and which belong to the end sections and the intermediate lower sections.

The different profiles comprising the chamber have, in their internal surface, at least in the end sections, grooves sized so as to permit tightening the screws introduced through holes in the end transversal lids. Besides, at least part of the profiles comprising the chamber are connected through screws, lengthwise to the adjacent overlap-

ping areas.

The module, comprised in the manner described, has three different areas. Two end zones, for the setting up and distribution of gas, with separate intakes on the upper section, and a central area for electric power, lighting, audio and video, also with separate intakes. The three areas, as we have indicated, are separated by intermediate transversal walls. The characteristic features of the module invented may, as appears in the claims, be better understood in the following description, which refers to the enclosed drawings, and which show only one possible manner of putting it together, due to its non-limitative character.

Drawings:

Figure 1 is a lateral view of a multifunctional module for medical services, assembled according to the invention.

Figure 2 is a transversal section of the module, shown lengthwise to cut line II-II of figure 1.

The multifunctional module shown in the drawings is composed of 1 elongated chamber with a continuous transversal section, approximately in the shape of an inverted isosceles trapezoid, as can be seen in Figure 2. This chamber is of horizontal tubular structure, comprised by longitudinal profiles which can be connected and set among them, and closed by means of end transversal lids identified with number 2.

In the example shown in the drawings, the tubular chamber is composed of six longitudinal profiles, four of which are locking profiles and which limit the shape of the chamber, and two for rigidity, which are part of the assembly set.

Of the four locking profiles, two of these, identified with # 3, are symmetrical among themselves and are approximately G-shaped, while the other two, identified with #4 and #5, are flat-shaped, so as to define the top and bottom locking lids to be set up between the coplanar edges of profiles #3.

Longitudinal locking profiles #3 limit the longitudinal walls of chamber #1 and longitudinal upper end zones #6 and bottom zones #7 of the base.

Bottom areas #7 of profiles #3 extend for ascending section #8 which presents shapes overlapping with the adjacent edges of profile #5 for connection between them and to take on the exterior rigidity profiles #9.

Profiles #3, #5 and #9 are joined by screws in the overlapping areas. Profiles #9 are used as embellishing elements and as elements for the rigidity of the whole set.

Upper areas #6 of profiles #3 and the profile or upper lid #4 show in their adjacent edges #10 shapes, which permit pressure mounting lid #4 to

the set.

The different profiles have in their interior surface, at least in the end section, grooves #11 so as to tighten the screws introduced by the holes in end lids #2.

The tubular chamber comprised in the manner described is subdivided into three separate areas by means of two transversal walls #12, figure #1.

Along the central area, limited by wall #12, the chamber can have available upper and interior lighting devices. To this end, the profile or lower lid #5 will have a longitudinal opening limited by interior ribs #13, between which a console or interior housing is set up #14, bearing lighting devices #15, while on the outside, diffusion cover #16, is set up. In the same manner, on the upper section, under lid #4, there can be set up a console or housing #17 with lighting devices #18, while upper lid #4 is comprised by a diffuser.

Each one of the end areas of the chamber, limited by walls #12 and end lids #2, is set up for the set up and distribution of gases, and these areas have separate intakes #19 on the top part for the supply connections. In the central section of the chamber, limited by walls #12, is destined to the location of the electric power area, including all necessary elements and electrical devices, such as plugs, ground connections, buttons, switches, transformers, audio and video switches, monitors, special devices, etc. Besides, these central areas, as we have pointed out, can also hold lower and top lighting devices, the first of which will light the area under the module, while the upper lighting devices can provide indirect lighting. Interior channels #11 of the profiles #3 may also be used for mounting the different accessories wherever desired. Locking profiles, identified with #3, #4, and #5, as well as rigidity profiles #9, may be made of aluminum, light alloys, plastic, etc. Maintaining the section of such profiles, the same may be cut to desired length, according to the size desired for chamber #1.

As you can understand, the profile section, fundamentally profiles #3, may vary slightly, without for this reason abandoning the framework of the invention, keeping always the chamber set by longitudinal profiles, which allow us to achieve a tubular structure subdivided by means of transversal walls into independent chambers, each of these destined to separate services, the supply of which is also done through separate intakes.

The terminations for the different electric services set up in the central area of the chamber, limited by walls #12, run through central column #20.

Claims

1. Multifunctional module for medical services, specially devised to be installed in zones or areas dedicated to medical care and/or treatment, featuring a horizontal tubular chamber (1) ,whose characteristic feature is a horizontal tubular chamber. Its approximate shape is that of an inverted isosceles trapezoid, composed of longitudinal profiles (3, 4, 5) which can be joined end set among themselves, complemented and assembled by means of closing end lids (12), and the chamber is subdivided by longitudinal walls (12), into three independent sections or zones, each of which has intakes for the different services which are supplied through independent upper columns (19 and 20), and the end sections of the chamber are reserved for the supply of different gases, while the central section includes devices for control, connections, and for the supply of transmission and electrical circuits, as well as lighting elements.
2. Module according to claim 1, whose characteristic is that the tubular chamber (1) is composed of four longitudinal locking profiles, two end ones (3) and two intermediate ones (4) and 5), which set the limits of the chamber contour, and by two external profiles for rigidity (9), and the longitudinal end profiles (3) have symmetric sections, approximately G-shaped, which define the slanting sides and adjacent sections of the bases in the chamber section and whose intermediate longitudinal profiles (4 and 5) are flat shaped to define the locking lids to be assembled between the coplanar edges of the end profiles, (3) and whose external profiles for rigidity (9) longitudinally embrace the connection area between the longitudinal end (3) and bottom (5) profiles.
3. Module which as per claim section 2, is characterized by locking end longitudinal profiles (3) are extended as of the section which forms part of the lower base of the chamber section, in two ascending sections (8), among whose longitudinal edges, the intermediate longitudinal lacking profile is mounted, determining a central depression all along the length of the chamber, limited laterally by the external rigidity profiles (9).
4. Module according to the above claims is characterized by the locking profiles (3, 4 and 5) having on their longitudinal sides a complementary structure (10) which can be connected among them, and in the internal surface,

grooves (11) for tightening the setting screws of the end lids (2).

5. Module which according to claims 1 and 2, is characterized by an intermediate longitudinal lower locking profile (5) which has, along the central section of the chamber (1) an opening limited by internal edges (13) among which a lighting console is set up (14) with a closing diffuser sheet (16). 5
10
6. Module which according to claims 1 and 2 is characterized by an intermediate upper locking longitudinal profile (4) transparent or translucent in nature, at least along the intermediate areas of the chamber (1) and which has interior longitudinal edges from which a lighting tray or console is hung (17). 15
20

20

25

30

35

40

45

50

55

4

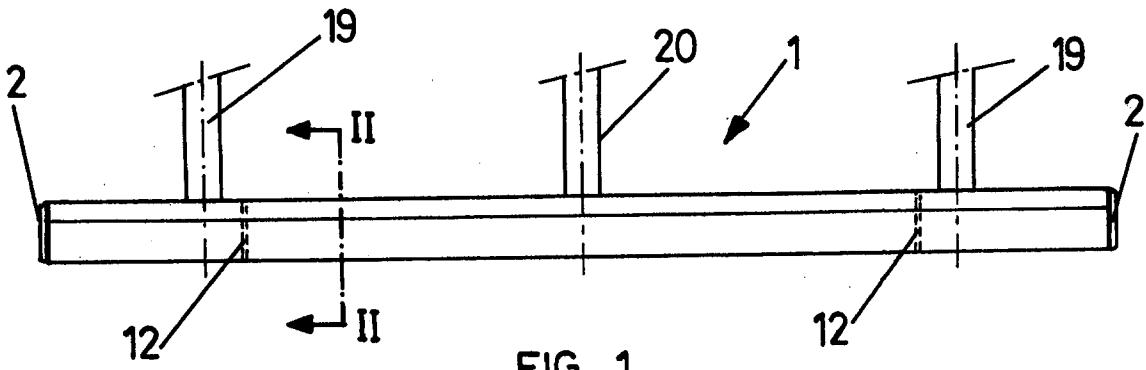

FIG. 1

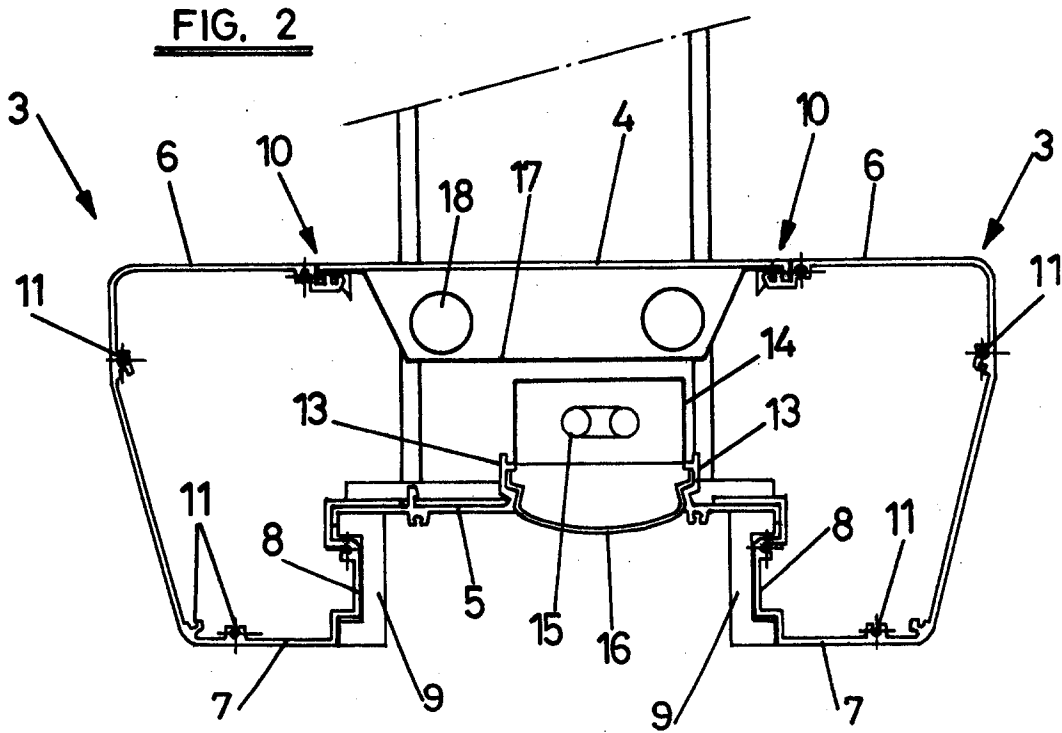

FIG. 2



DOCUMENTS CONSIDERED TO BE RELEVANT			CLASSIFICATION OF THE APPLICATION (Int. Cl.5)
Category	Citation of document with indication, where appropriate, of relevant passages	Relevant to claim	
X	EP-A-0 215 212 (TRILUX-LENZE GMBH & CO. KG.) * the whole document * ---	1-6	A61G12/00
X	FR-A-2 614 736 (TRILUX-LENZE GMBH & CO. KG.) * page 5, line 3 - page 7, line 35; figures 1,2 * ---	1,2	
A	DE-A-3 812 798 (TRILUX - LENZE GMBH & CO. KG.) * abstract; figures * -----	1	
			TECHNICAL FIELDS SEARCHED (Int. Cl.5)
			A61G
The present search report has been drawn up for all claims			
Place of search	Date of completion of the search	Examiner	
THE HAGUE	09 JUNE 1993	BAERT F.	
CATEGORY OF CITED DOCUMENTS		T : theory or principle underlying the invention	
X : particularly relevant if taken alone		E : earlier patent document, but published on, or after the filing date	
Y : particularly relevant if combined with another document of the same category		D : document cited in the application	
A : technological background		L : document cited for other reasons	
O : non-written disclosure		& : member of the same patent family, corresponding document	
P : intermediate document			