



Europäisches Patentamt  
European Patent Office  
Office européen des brevets



Publication number: **0 573 858 A1**

**EUROPEAN PATENT APPLICATION**

Application number: **93108643.3**

Int. Cl.<sup>5</sup>: **E04H 6/28**

Date of filing: **28.05.93**

Priority: **12.06.92 IT UD920108**

Applicant: **Fabris, Domenico**  
**Via Cavedalis 4**  
**I-33010 Osoppo (UD)(IT)**

Date of publication of application:  
**15.12.93 Bulletin 93/50**

Inventor: **Fabris, Domenico**  
**Via Cavedalis 4**  
**I-33010 Osoppo (UD)(IT)**

Designated Contracting States:  
**CH DE ES FR GB GR IT LI PT**

Representative: **Petraz, Gilberto Luigi**  
**GLP S.r.l.**  
**Piazzale Cavedalis 6/2**  
**I-33100 Udine (IT)**

**Multistorey, automated car park.**

Multistorey, automated car park of a substantially underground type for motor vehicles, with a station (39) at ground level for incoming motor vehicles to be parked, which car park comprises a well (11) containing a plurality of platforms (13) able to rotate together about a central axis for the parking of motor vehicles, the platforms (13) being connected together by a three-dimensional structure (29) so as

to create a rotary conveyor system, which is contained in a structure (12) able to move vertically within the well (11), the vertically movable structure (12) including at its upper end a roof (16) and at its lower end an equipped platform (15a), which (15a) cooperates with means (14) that perform vertical lifting and with buffer means (20).

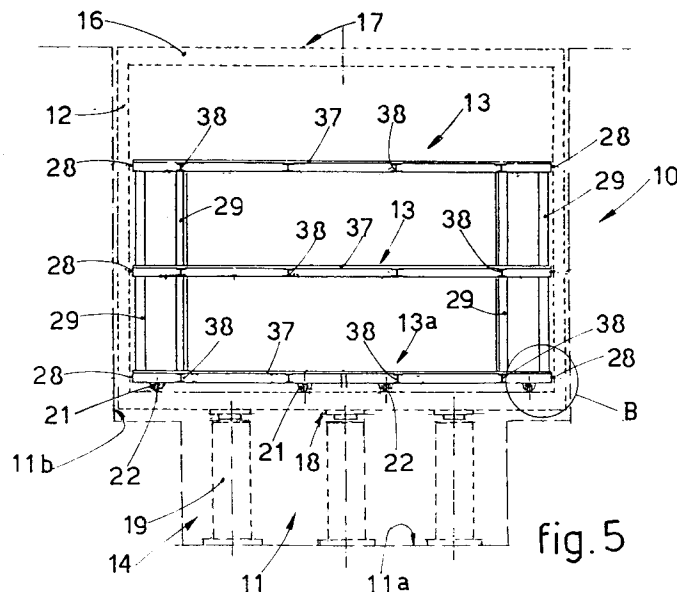

**EP 0 573 858 A1**

This invention concerns a multistorey, automated car park, as set forth in the main claim. To be more exact, the multistorey, automated car park according to the invention is suitable to hold motor vehicles and can be used as a private car park or as a public car park against payment.

The problem of the parking of motor vehicles is becoming more and more serious, and users are seeking a solution to this problem ever more insistently, especially in areas where little space is available for parking motor vehicles by day or by night.

Large underground car parks with the traditional ramps have been proposed to meet the lack of space available for parking but have not overcome the various working aspects of the problem. In fact, these car parks lead to another whole set of shortcomings, amongst which are the difficulties of manoeuvring when parking and removing the motor vehicles, pollution by the exhaust gases, excessive noise and the personal safety of the users and of the community.

Furthermore, these underground car parks with the traditional ramps become financially advantageous only when they are set up on a huge scale, and are not economical for use on a small scale with a few motor vehicles, as would be the case with small communities such as blocks of flats, for instance.

Multistorey car parks have been disclosed which have the advantage of occupying a smaller surface of public ground for an equal number of vehicles parked.

Some such multistorey car parks can be made in large sizes or on a small scale for use as a private car park for small communities or blocks of flats, for instance.

US-A-1,966,165 discloses an external multistorey car park including a vertically movable, central elevator cooperating on each side with a building in which parking places for cars are arranged side by side on each floor.

The plan of the elevator comprises means for the rotation and lateral traversing of the vehicle and also means to load or unload the vehicles onto or from the desired parking space.

This system is very complex and expensive and requires a long time for delivering or removing a motor vehicle since the vehicles are delivered or removed one by one.

Moreover, the car park rises above ground level and therefore has a great impact on the environment. This system is thus not suitable for small scale use since it would not be economically convenient.

BE-A-642.480 discloses a multistorey car park in which the elevator has a great size to convey a great number of motor vehicles at the same time

and comprises central guide means consisting of a central pillar cooperating with the vertical guide means of the elevator. The vehicles are arranged in the manner of spokes in the elevator and are loaded or unloaded automatically onto or from appropriate spaces in the stationary structure surrounding the elevator.

This parking system enables a plurality of vehicles to be removed or delivered at the same time but requires very great spaces and investments, which can only be justified when the car park is of a great size.

The multistorey car parks described above are advantageous only if they are very big, as they require great spaces for their lay-out, for the parking positions are located outside the means which lifts the vehicle.

US-A-2,687,815 discloses a partly underground, multistorey car park in which the vehicles are parked on the upper floors by an elevator, whereas the multistorey structure itself is lifted for parking on the lower floors.

A rotation device is included on each floor and enables the vehicle to be faced towards the outlet. The devices disclosed cannot be made in small sizes and require heavy investments since their lay-out is very complex.

CH-A-336.976 discloses a car park consisting of a plurality of elevators able to run vertically, each elevator comprising a plurality of superimposed platforms on each of which one vehicle alone is placed. This fact leads to a plurality of lifting means, guides means and vehicle acceptance spaces together with an appreciable increase in building costs and installed power, for each elevator is independent of the others and requires a whole set of accessories.

FR-A-1.601.351 discloses a retractable, underground car park including a cylindrical well, in which is installed a movable structure consisting of an elevator formed with a plurality of superimposed platforms solidly fixed together; the elevator cooperates with a central pillar acting as a guide for the vertical movement and for the rotation of the movable structure.

This central pillar not only reduces the space available for the vehicles but also has a great effect on their arrangement, since the vehicles cannot be arranged as desired over the whole surface of the platforms.

Suitable lifting and rotation means are included for the vertical and angular positioning of the movable structure. The multistorey car park emerges from the ground only at the time of removal or delivery of a vehicle and remains below ground for most of the time, thus causing no impact on the environment and being perfectly suitable for integration into an urban background.

The multistorey car park disclosed above involves a series of problems linked to the fact that the rotary movement of the movable structure has to be carried out while the elevator is in its lowered retracted position, thus lengthening the times for delivery or removal of the vehicle parked or to be parked.

Moreover, in the emerging position of the movable structure the platforms are not guided at their sides, and this situation may lead to great problems owing to oscillation and to unsteadiness of the movable structure itself, above all when the vehicles are not arranged symmetrically.

The present applicant has designed, tested and obtained this invention so as to overcome the shortcomings of the state of the art and to achieve further advantages.

The invention is set forth and characterized in the main claim, while the dependent claims describe variants of the idea of the main solution.

The purpose of this invention is to provide users with a multistorey, automated system to park a plurality of motor vehicles in a simple and safe manner within a short space of time.

A further purpose of this invention is to provide a car park having very small dimensions and a simple structure and being especially suitable to hold a limited number of motor vehicles.

The multistorey car park according to the invention is of an underground type and includes a station for arrival of the vehicles at ground level; for safety reasons this station is separated advantageously from the car park itself by a movable bar actuated by the driver.

According to a variant the arrival station for the vehicle will include a second movable access bar positioned upstream.

The multistorey car park according to the invention includes a substantially cylindrical well with which a vertically movable structure that positions and holds the parked vehicles cooperates.

A rotary conveyor system is installed in the vertically movable structure and consists of a plurality of coaxial, parallel platforms suitably spaced apart and solidly fixed together by a three-dimensional structure.

The vertically movable structure according to the invention comprises at its lower end an equipped platform cooperating with lifting means and at its upper end a roof which lies advantageously at ground level when the movable structure is in its lower retracted position.

The vertically movable structure connects the lowest equipped platform to the roof and may include in a vertical direction a space for access coinciding with the vehicle arrival station.

Thus, the structure of the car park according to the invention is very solid, rigid and stable.

So as to reduce the overall dimensions of the car park and leave the whole surface of the platforms free to hold vehicles, the means which guide the ascent and descent of the vertically movable structure and the rotation of the rotary conveyor system are positioned perimetrically so as not to interfere with the positions of the vehicles.

So as to ensure a correct vertical movement of the car park and to prevent any oscillations or tilting, the vertically movable structure comprises vertical uprights with idler wheels that cooperate with vertical stationary guides on the perimetric containing structure.

According to a variant these idler guide wheels contain an outer toothing that cooperates with vertical racks anchored to the vertical containing structure.

In the car park according to the invention each platform contains at least three places for vehicles.

Cradles are positioned on the platforms at the places for vehicles and are suitable to receive and lodge the two front wheels of each vehicle; these cradles serve as a reference point and clamping system for the vehicle.

Each platform contains advantageously a trap-door which makes access possible to the other platforms and to the lifting device by using a ladder.

It is also possible to reach the lifting device advantageously by means of an appropriate emergency opening made in the containing structure.

The lowest platform includes at its lower part means to actuate and control rotation which cooperate with meshing means positioned on the vertically movable structure.

Suitable motor means make the vertically movable structure ascend and descend and cause the rotary conveyor system to rotate until the required platform with the selected parking place coincides with the intake path of the motor vehicle.

According to the invention, so as to assist rotation of the structure, the structure connecting the platforms together and constituting therewith the rotary conveyor system is equipped on its periphery with idler wheels having their axis parallel to the axis of rotation of the rotary conveyor system; these idler wheels cooperate with circular guides located on the inner surface of the vertically movable structure.

In this way the movements of ascent and descent and the movement of rotation of the car park according to the invention can be carried out at the same time, thus shortening the times employed in removing or parking the vehicles without thereby causing undesirable, dangerous vibrations or oscillations, since even when the car park emerges above ground level, the rotary conveyor system is guided both at its lower end and about its periph-

ery.

Moreover, the car park according to the invention comprises also a set of accessories such as an automatic device to control intake and removal of a vehicle, a control panel to bring the desired parking place to the zone of delivery and removal of the vehicle, security means which permit users alone to accede to the zone of delivery and removal of the vehicle, and other suitable means.

Where the car park is for public use, the control panel is replaced by an optical panel and continuous cash box which perform all the operations of moving and financial management of the car park.

All the operations connected with the working of the lifting plant, vertically movable structure and rotary conveyor system are governed by a control unit operated by the driver himself when parking or removing his vehicle.

The vertically movable structure cooperates at its lower end during descent and, in particular at the end of its descent, with buffer means, which are positioned on the concrete bed of the well and have the task of preventing a sharp halt of the vertically movable structure.

For the sake of safety the zone surrounding the car park is protected, for instance, by a stationary protection for pedestrians; such as a flower bed, a mesh structure or another means suitable for the purpose, while the zone of access to the platforms is protected by a movable bar.

This movable bar is raised automatically when the user has started the cycle of operations for the intake or removal of his vehicle.

The attached figures, which are given as a non-restrictive example, show a preferred lay-out of the invention as follows:

- Fig.1 is a plan view of the car park according to the invention;
- Fig.2 is a diagrammatic plan view of a rotary conveyor system according to the invention;
- Fig.3 is a diagrammatic plan view of the equipped platform forming the bottom of the vertically movable structure according to the invention;
- Fig.4 is a diagrammatic side view of the vertically movable structure of Fig.3;
- Fig.5 is a diagrammatic side view of the rotary conveyor system cooperating with the vertically movable structure of Fig.4;
- Fig.6 shows the detail A of Fig.4 in an enlarged scale;
- Fig.7 shows the detail B of Fig.5 in an enlarged scale.

The reference number 10 in the figures indicates generally a multistorey, automated car park

according to the invention.

The multistorey, automated car park 10 is located in a well 11 excavated in the ground and having a substantially cylindrical shape and a vertical axis. Both the bottom 11a and the perimetric walls 11b of the well 11 are made advantageously of reinforced concrete.

A vertically movable structure 12 having a substantially cylindrical shape and cooperating at its lower end with a lifting means 14 is installed within the well 11.

A rotary conveyor system consisting of a plurality of platforms 13 connected together by a three-dimensional structure 29 of steel sections so as to form one single structure is rotatably installed within the vertically movable structure 12.

In this case three places for cars positioned side by side are provided advantageously on each platform 13.

A station 39 for incoming motor vehicles to be parked is included at the access to the car park 10 according to the invention and is possibly lit advantageously by a suitable lighting device consisting of a lamp post, for instance.

The vertically movable structure 12 consists of an equipped platform 15a consisting, for instance, of steel sections and able to uphold the whole weight of the vertically movable structure 12 of the car park 10 and of a vertical and perimetrically arranged supporting structure 15b consisting of steel sections, for instance. The vertical supporting structure 15b supports a roof 16 of the car park 10 and an overlying floor 17.

The overlying floor 17 of the car park 10 consists, for instance, of striated steel sheet or another type of flooring such as a green lawn, for instance.

The vertical supporting structure 15b can extend advantageously along almost the whole periphery of the vertically movable structure 12 and will leave free only an opening needed for passage of the vehicles.

Such a cylindrical structure ensures great rigidity for the vertically movable structure 12 even when the latter 12 is protruding upwards from the well 11.

The equipped platform 15a is secured to a plate 18 of the lifting means 14, which in this case consists of three hydraulic pistons 19, and cooperates with buffers 20 that resist the descent of the vertically movable structure 12 at the end of its travel.

The equipped platform 15a comprises on its upper surface circular guides 21, which cooperates with supporting and movement wheels 22 fitted below the lowest platform 13a forming the bottom of the rotary conveyor system.

The platforms 13 in this example consist of a horizontal structure of steel sections 38, which sup-

port an overlying floor made of striated steel sheet 37.

The motion of rotation of the rotary conveyor system is provided by a motor 23, of an electric type for instance, equipped with an automatic reversing switch 24, so that the rotary conveyor system can be rotated clockwise or anti-clockwise. In this example the motor 23 actuates a vertical shaft 31 solidly fixed to the rotary conveyor system.

A trap door 40 is made advantageously in each platform 13 and, by using a ladder which is not shown here, provides access to the lower platforms 13 and to the lifting means 14 positioned in the lower part of the well 11.

According to a variant the vertically movable structure 12 contains an intake opening extending vertically in cooperation with the vehicle arrival station 39.

Idler wheels 25 are included on the outer periphery of the vertical supporting structure 15b so as to prevent any sideways displacements of the vertically movable structure 12 during its ascent or descent. Each of the idler wheels 25 is fitted with its axis substantially horizontal and cooperates with mating guide means 26 extending vertically on the perimetric sidewall 11b of the well 11.

According to a variant the idler wheels 25 possess an outer toothing and cooperate with vertical racks positioned on the perimetric containing sidewall 11b, thus ensuring a more efficient guiding system.

The vertically movable structure 12 according to the invention comprises peripherally and internally a plurality of circumferential and substantially horizontal guides 27 to guide wheels 28, these guides consisting of a channel section in this case and coinciding with each platform 13.

The wheels 28, which have a substantially vertical axis and protrude from the perimeter of each platform 13, cooperate with those circumferential guides 27. The wheels 28 and guides 27 ensure proper rotation of the rotary conveyor system in both directions even when the vertically movable structure 12 is outside the well 11, thus obviating possible listing of the conveyor system of platforms 13 caused by an uneven distribution of the motor vehicles on the various platforms 13.

Steel cradles 30 are positioned on the floor 37 of each platform 13 at each vehicle position and are suitable to accept and lodge the two front wheels of each vehicle.

The cylindrical lateral surface of the vertically movable structure 12 may include a suitable protective mesh 32 stretching along the whole height of the structure 12 and containing an opening coinciding with the vehicle intake path.

The roof 16 may consist of striated steel sheet or another type of cover, not excluding a grassy

lawn.

For safety reasons the station 39 for incoming motor vehicles to be parked is separated advantageously from the road leading to the car park 10 according to the invention by a movable bar 33, and the zone of the car park 10 itself is surrounded by a stationary protective system consisting, for instance, of a flower bed 34 or a stationary barrier to prevent non-users arriving at the car park 10.

According to a variant a second movable bar 133 may be included and be located upstream of the vehicle arrival station 39 so as to control access.

A stand 35 is located beside the movable bar 33 and bears a control panel 36 of the park 10, this control panel 36 being connected directly to a governing and control device 41 employed in the control of the car park 10.

The governing and control device 41 is itself governed advantageously by a calculator, which manages all operations concerned with the exploitation of the park 10 according to the invention.

The steel structures forming the car park 10 according to the invention are coated advantageously with a fireproof paint to meet the fire-prevention regulations.

We shall now describe the various main steps in the functioning of the car park 10 according to the invention.

To park his vehicle in the car park 10, the driver stops with his vehicle beside the stand 35 bearing the control panel 36 of the park 10 and positioned at the entry of the same 10.

When the appropriate key is inserted into the keyhole corresponding to the desired parking place, the governing and control device 41 sends signals whereby the vertically movable structure 12 ascends until it has brought the rotary conveyor system with the desired platform 13 to the removal plane, while the motor 23 rotates the rotary conveyor system so as to bring the desired parking place to coincide with the vehicle entry path.

According to a variant the rotation of the rotary conveyor system can take place before, during or after the ascent of the vertically movable structure 12.

When the vertically movable structure 12 and the rotary conveyor system have halted, the movable bar 33 rises and the driver can reach his vehicle parking place on the platform 13 halted at ground level; he stops his vehicle with the two front wheels in the two cradles 30 positioned on the floor 37.

When the vehicle has been positioned, left open or closed, clamped or free, the driver gets out of his vehicle and leaves the car park 10.

When the key is taken from the key-hole, the movable bar 33 drops automatically and obstructs

access to the car park 10, while the vertically movable structure 12 descends into the well 11 until it has brought the flooring 17 overlying the roof 16 of the car park 10 to the level of the surrounding ground.

To withdraw his vehicle from the car park 10 according to the invention, the driver inserts his actuation key in the keyhole of his vehicle parking number in the control panel 36 located on the stand 35 of the park 10.

The second movable bar 133 is lowered to prevent access to the vehicle arrival station 39.

The vertically movable structure 12 ascends while the rotary conveyor system rotates to arrange the vehicle with its front end facing in the outgoing direction so as to facilitate the manoeuvres for leaving the park 10.

When the vertically movable structure 12 halts with the required platform 13 coinciding with the reference plane, the first movable bar 33 of the vehicle arrival station 39 rises.

The driver then removes his own vehicle and stops beyond the first movable bar 33.

The driver now takes his key from its keyhole, the second movable bar 133 rises and the driver departs, while the first movable bar 33 is lowered and the vertically movable structure 12 descends to bring the flooring 17 on the roof 16 of the car park 10 to ground level.

## Claims

1. Multistorey, automated car park of a substantially underground type for motor vehicles, with a station (39) at ground level for incoming motor vehicles to be parked, which car park comprises a well (11) containing a plurality of platforms able to rotate together about a central axis for the parking of motor vehicles and is characterized in that the platforms (13) are connected together by a three-dimensional structure (29) so as to create a rotary conveyor system, which is contained in a structure (12) able to move vertically within the well (11), the vertically movable structure (12) including at its upper end a roof (16) and at its lower end an equipped platform (15a), which (15a) cooperates with means (14) that perform vertical lifting and with buffer means (20).
2. Car park as in Claim 1, in which the rotary conveyor system includes circumferentially at least one plurality of wheels (28) able to run circumferentially and lying on a substantially horizontal plane, each plurality of wheels (28) cooperating with a circumferential and substantially horizontal mating guide (27) solidly secured to the vertically movable structure (12).
3. Car park as in Claim 1 or 2, in which the vertically movable structure (12) comprises on its exterior idler wheels (25) able to run vertically and cooperating with vertical guides (26) secured to a perimetric structure (11b) of the well (11).
4. Car park as in Claim 1 or 2, in which the vertically movable structure (12) comprises on its exterior toothed idler wheels (25) able to run vertically and cooperating with vertical rack means (26) secured to the perimetric structure (11b) of the well (11).
5. Car park as in any claim hereinbefore, in which the equipped platform (15a) includes means (23-24) for the rotary movement of the rotary conveyor system and also circumferential guide means (21) cooperating with wheels (22) which uphold the rotary conveyor system and are positioned in the underlying part of the rotary conveyor system.
6. Car park as in any claim hereinbefore, in which the vertically movable structure (12) includes an access opening extending vertically in cooperation with the station (39) for incoming vehicles.
7. Car park as in any claim hereinbefore, which includes governing and control means (41) governed by a calculator.

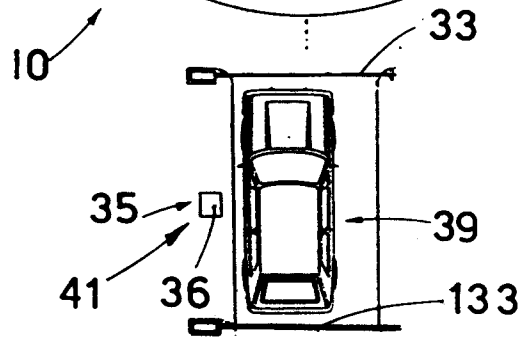
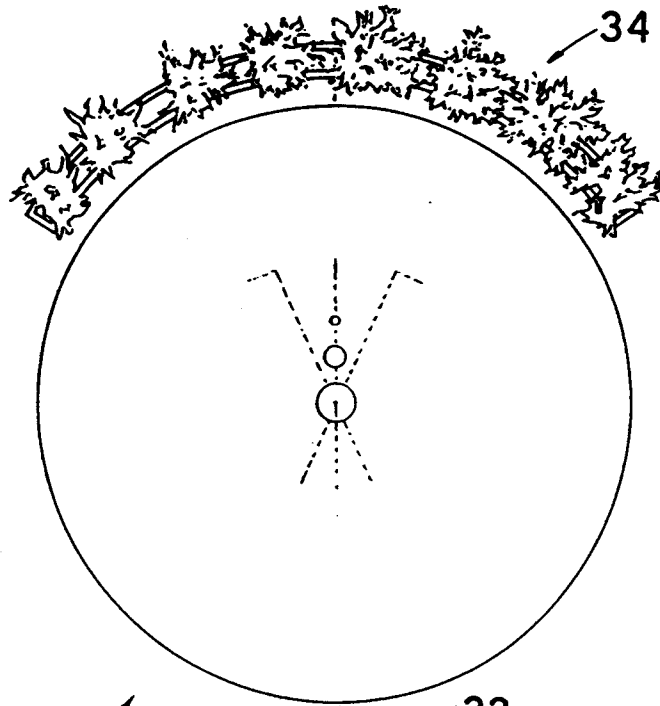

fig. 1

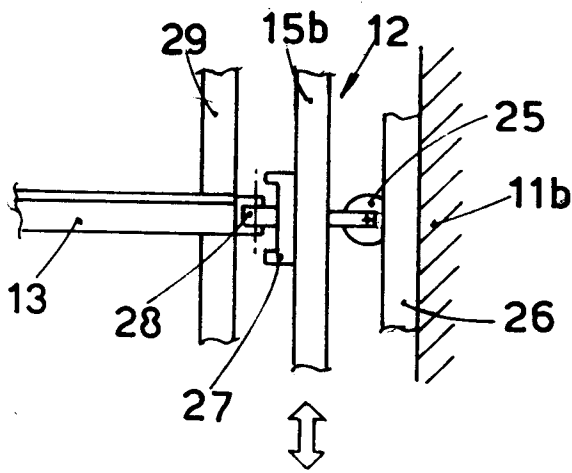

fig. 6

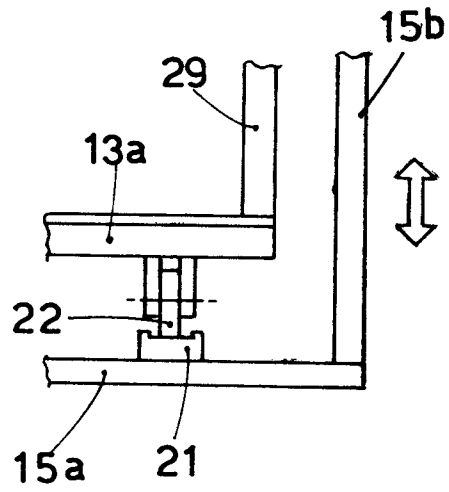
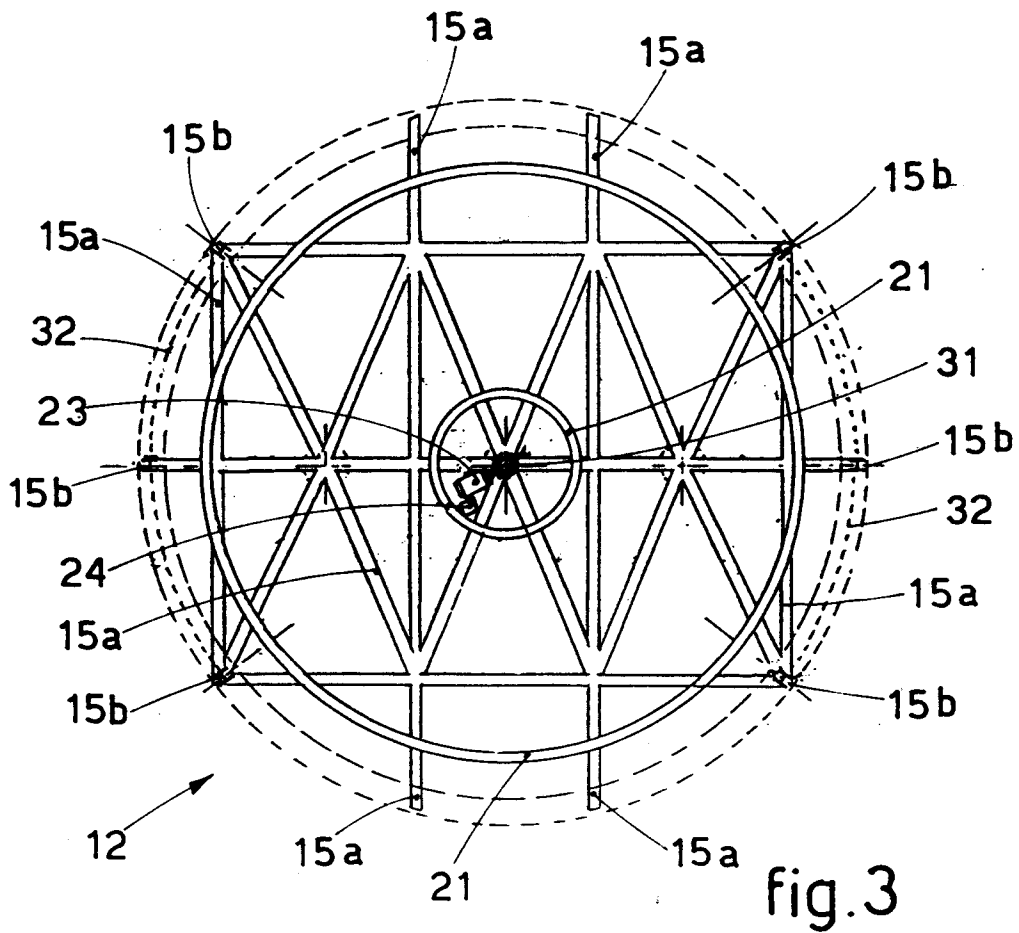
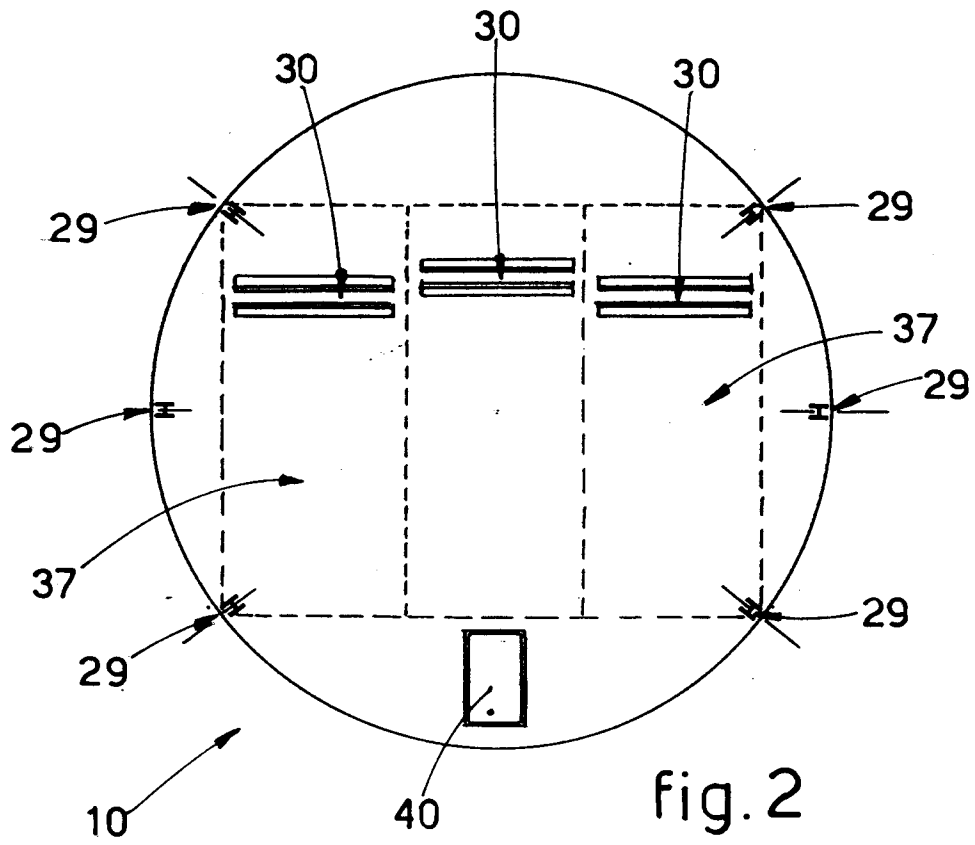

fig. 7



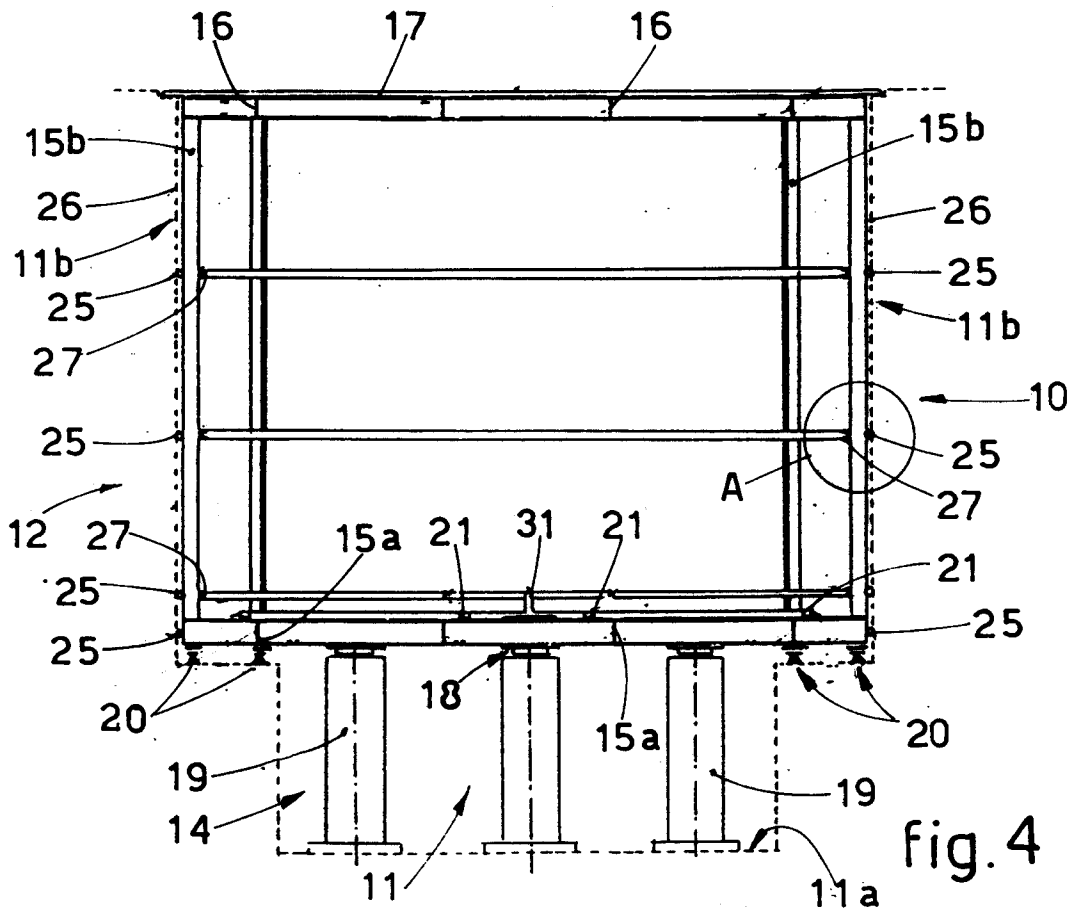

fig. 4

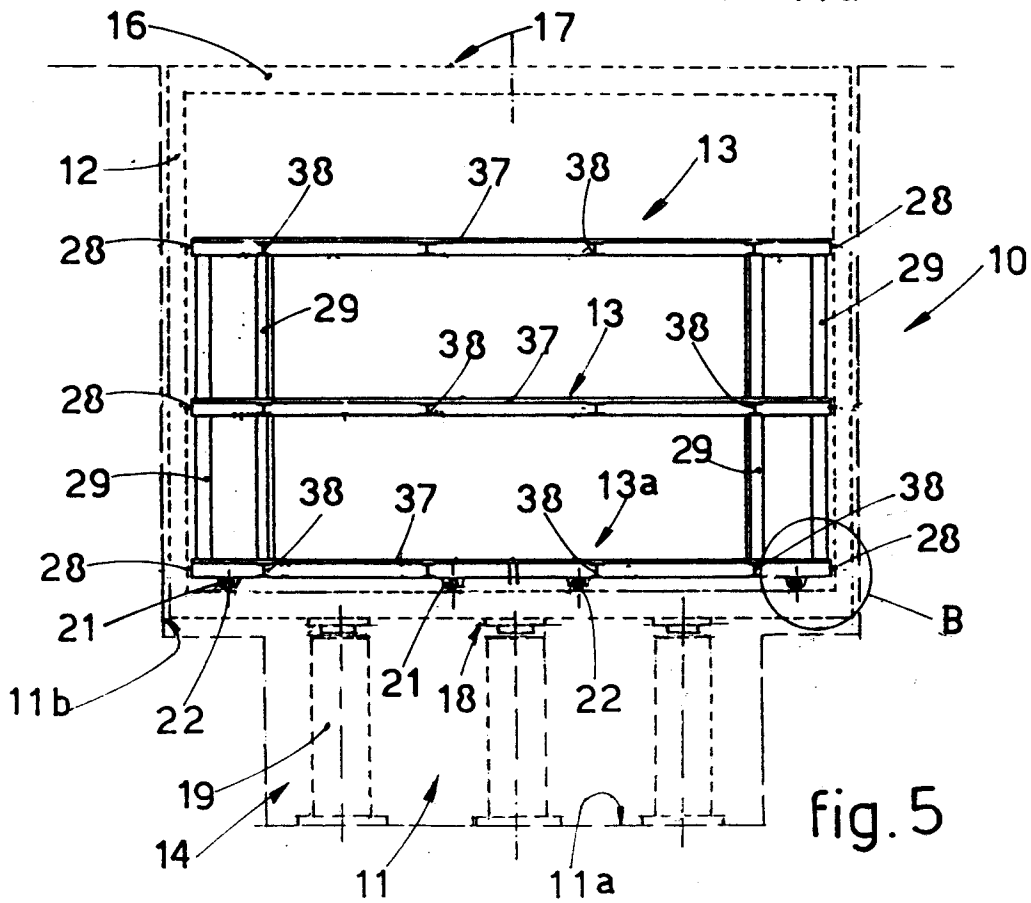

fig. 5



DOCUMENTS CONSIDERED TO BE RELEVANT				
Category	Citation of document with indication, where appropriate, of relevant passages	Relevant to claim	CLASSIFICATION OF THE APPLICATION (Int. Cl.5)	
D,A	FR-A-1 601 351 (PATIN) * the whole document * ---	1,5	E04H6/28	
D,A	BE-A-642 480 (LES ANCIENS ETABLISSEMENTS COULETTE SARL) * page 2, line 30 - page 3, line 12 * * page 5, line 2 - line 5 * * page 6, line 2 - line 10; figures 1,5 * ---	1,5		
A	CH-A-431 911 (BEAU) * column 5, line 33 - column 6, line 8; figures 5,6 * ---	2		
A	DE-B-1 280 542 (SCHÄFER) * column 3, line 20 - line 58; figures 1-3 * ---	3		
D,A	CH-A-336 976 (ELSAESSER) * page 1, line 31 - line 68; figures 1,2 * ---	4		
D,A	US-A-1 966 165 (CLYDE) * page 1, line 106 - page 2, line 35; figures 1,3,4 * ---	5		TECHNICAL FIELDS SEARCHED (Int. Cl.5)
D,A	US-A-2 687 815 (SIMON) -----			E04H
The present search report has been drawn up for all claims				
Place of search THE HAGUE		Date of completion of the search 16 SEPTEMBER 1993	Examiner PORWOLL H.P.	
<b>CATEGORY OF CITED DOCUMENTS</b> X : particularly relevant if taken alone Y : particularly relevant if combined with another document of the same category A : technological background O : non-written disclosure P : intermediate document		T : theory or principle underlying the invention E : earlier patent document, but published on, or after the filing date D : document cited in the application L : document cited for other reasons ..... & : member of the same patent family, corresponding document		