



Europäisches Patentamt
European Patent Office
Office européen des brevets



Publication number: **0 575 004 A1**

EUROPEAN PATENT APPLICATION

Application number: **93201721.3**

Int. Cl.⁵: **B65D 5/00, B65D 5/36**

Date of filing: **17.06.93**

Priority: **17.06.92 NL 9201068**

Date of publication of application:
22.12.93 Bulletin 93/51

Designated Contracting States:
BE CH DE ES FR GB GR IT LI LU NL PT

Applicant: **Trimbach Verpakking B.V.**
Ravelstraat 28
NL-4614 XD Bergen op Zoom(NL)

Inventor: **Van de Poel, Cornelus Ludovicus Maria**
Heijmansven 6
NL-4635 DE Huijbergen(NL)
Inventor: **de Ron, Cornelis Johannes**

Beukendreef 21
B-2190 Essen(BE)
Inventor: **Trimbach, Raijmundus Gerardus Lambertus Joseph Jeneverbes 1**
NL-4635 BN Huijbergen(NL)
Inventor: **Buuron, Petrus**
Acacialaan 6
NL-4621 EZ Bergen op Zoom(NL)

Representative: **Smulders, Theodorus A.H.J., Ir. et al**
Vereenigde Octrooibureaux
Nieuwe Parklaan 97
NL-2587 BN 's-Gravenhage (NL)

Collapsible folded box with reinforced tubular corner structure.

A ready-to-use box that can be made from a blank by folding and adhesion, comprising a bottom surface (1) and upright longitudinal and transverse walls (2, 3) connected to the bottom surface by four fold lines (4, 5) bounding the bottom surface, whilst at the corners where upright walls (2, 3) meet, collapsible tubular corner support structures are formed, each tubular corner support structure comprising a corner support panel (10c) which, in the erected condition of the box, substantially extends from a first upright box wall (2) to the corresponding corner and terminates at a distance therefrom in a fold line (12b), from which fold line (12b) a second corner support panel (10b) extends to the adjacent second upright box wall (3), and a third corner support panel (10e) likewise extends from the first upright box wall (2), at an acute angle relative to the first corner support panel (10c), to the fold line (12b) between the first (10c) and the second corner support panel (10b).

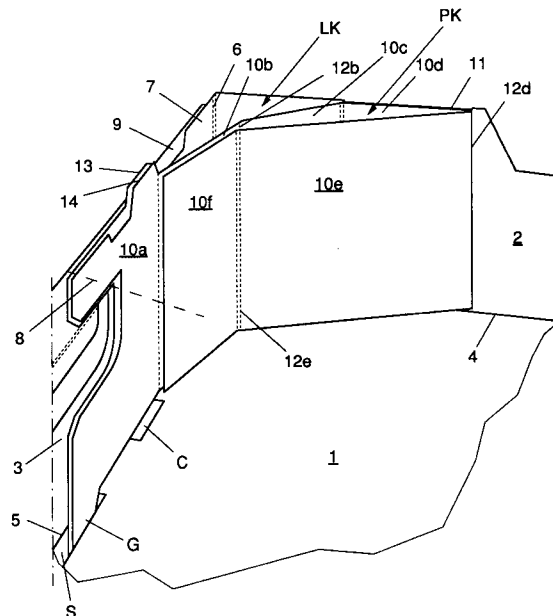

FIG. 2

EP 0 575 004 A1

This invention relates to a ready-to-use box which is provided with a tubular corner support structure at the corners for improving stackability.

A ready-to-use box is a box which, by virtue of a specific corner connection, permits the upright walls thereof, while mutually connected, to be collapsed onto the bottom of the box, so that the finished box can be stored without occupying much space. To make the box ready for use, only the collapsed walls need to be erected and the box is ready for receiving products, for instance vegetables or fruit. In addition to ready-to-use boxes, set-up boxes are known, which can likewise be formed from a blank but require a number of operations to be performed for making them ready for use, such as the separate erection of the sidewalls and effecting corner connections through stapling, glueing, by slipping locking tabs into receiving openings, or other operations which consume time that is often not available when vegetables or fruit are being packaged directly after harvesting.

Various corner support constructions are known for reinforcing the corner zones of a ready-to-use tray with a view to preventing the vertical walls of boxes in a stack from bending under the influence of the weight of superjacent boxes.

GB-A-2,196,608, for instance, describes a ready-to-use box where, in the corner zones, corner support tubes have been formed from flaps provided with parallel fold lines, these flaps being situated between the collapsed walls and the bottom of the box in the collapsed condition of the box. In the erected box, the corner support tubes have the form of quadrilateral prisms, two of the sides thereof being in abutment with the upright walls of the box that meet in the corner in question and the two other sides reaching into the interior of the box.

A drawback of such prismatic corner supports with a sharp edge or rib projecting into the interior of the box is that they reduce the useful interior space of the box and are unacceptable for certain products, such as soft fruit, on account of the associated risk of damage to the products.

Under the last-mentioned conditions, after the box has been erected, the corner support tubes extending into the interior of the box would have to be manually formed into tubes with a concave profile facing the interior of the box, i.e., the inwardly directed sharp edge of the prismatic tubular leg is bent further into the direction of the box corner in question, which has as a supplementary advantage that the support leg and the box as a whole acquire more robustness, more specifically, the torsional stiffness and the stability of the box upon dynamic loading are increased by virtue of the corner zones of the box being subject to tension. This situation is shown in Fig. 4 of GB-A-

2,196,608.

A disadvantage of this procedure, in particular the outward deformation of each of the legs is that it is time-consuming and detracts from the principle of a ready-to-use box, according to which the box should be ready for use directly after erection of the box walls from the collapsed transport position.

Another disadvantage is that, if the above-described deformation of the corner support tubes is to result in a stiffening of the box as a whole, the box must be glued and folded very accurately.

The object of the invention is to provide a box of the subject type which maintains the advantages of the tubular corner support structures in a ready-to-use box, but does not have the drawbacks mentioned.

To that end, a ready-to-use box that can be made from a blank by folding and adhesion, comprising a bottom surface and upright longitudinal and transverse walls connected to the bottom surface by four fold lines bounding said bottom surface, whilst at the corners where upright walls meet, one of the upright walls is provided with a connecting flap connected to the upright wall by a fold line, and the other upright wall comprises a triangular connection zone bounded by a fold line starting from the bottom corner point at a 45° angle, which connection zone, after being folded back, as viewed from the interior of the box, against the outside of that upright wall, is attached by adhesion to the outside of the connecting flap, whilst collapsible tubular corner support structures are formed from corner support flaps provided with fold lines, these corner support flaps being connected to an upright wall part of the box, is characterized in that each tubular corner support structure comprises a corner support panel which, in the erected condition of the box, extends from a first upright box wall to the corresponding corner and terminates at a distance therefrom in a fold line, from which fold line a second corner support panel extends to the adjacent second upright box wall, and a third corner support panel likewise extends from the first upright box wall, at an acute angle relative to the first corner support panel, to the fold line between the first and the second corner support panel.

In the erected position of the ready-to-use box according to the invention, in each corner zone a substantially flat tube can be formed, having a generally L-shaped cross-section as seen in top plan view of the erected box, this tube being bounded on the outside by portions of the upright box walls meeting in that corner zone and on the inside by the first and the second corner support panels, the third corner support panel increasing the stability of the inner boundary of the L tube.

Further, according to the invention, the stability of the corner support structure can be improved by folding a fourth corner support panel, which is connected to the third corner support panel by a fold line, back over the third corner support panel, the fold line being situated near the fold line between the first and the second corner support panel. The part of the corner support structure that serves as a bearing for a superjacent box in a stack is thus enhanced and stiffened.

Alternatively, in a preferred embodiment of the invention, the fourth corner support panel, connected to the third corner support panel by a fold line, may be connected with the second corner support panel, such that the fold line between the third and the fourth corner support panels is situated near the fold line between the first and the second corner support panels in the collapsed position of the box.

In this embodiment, in the erected condition of the box, the corner support structure will comprise, in addition to the tube of L-shaped cross-section, a second flat tube, which, on the side of the interior of the box, is bounded by the third corner support panel and which overlaps one of the legs of the L-shaped tube. This will yield not only a further increase of the stability of the corner support structure but also a further enlargement of the bearing for the corner zone of a superjacent box in a stack.

Further advantages of the invention, such as improved centering possibilities for boxes in a stack, will appear from the following description of some exemplary embodiments of the invention with reference to the accompanying drawings. In these drawings:

Fig. 1 is a view of substantially a quarter of an otherwise symmetrically designed blank for making the box according to the invention;

Fig. 1A is a detail of the blank shown in Fig. 1 in a variant embodiment;

Fig. 2 is a perspective view of a corner zone of the box in erected position in a first embodiment;

Fig. 3 shows the corner zone shown in Fig. 2 during the erection of the box walls from the transport position into the service position;

Fig. 3A is an elevation similar to Fig. 3, of the variant embodiment depicted in Fig. 1A;

Fig. 4 is an elevation similar to Fig. 2 of a variant embodiment of the box; and

Fig. 5 is an elevation similar to Figs. 2 and 4, of an embodiment which differs from the embodiments shown in Figs. 1-3 and Fig. 4, respectively, with respect to the centering means between respective boxes in a stack.

According to the drawings, in particular the blank shown in Fig. 1, the box comprises a bottom surface 1 and upright sidewalls 2 and 3, connected

to the bottom surface by fold lines 4 and 5, respectively.

Adjacent each corner, where upright walls 2 and 3 meet, one of the upright walls 2 is provided with a connecting flap 7 connected thereto by a fold line 6, and in the other upright wall 3 a triangular connection zone 9 is bounded by a fold line 8 starting from the bottom corner point at a 45° angle, which connection zone, after being folded back against the outside (as viewed from the interior of the box) of the upright wall 3, is attached through adhesion to the outside of the connecting flap 7 referred to. Since this form of corner connection is generally known in ready-to-use boxes, the folding mechanism thus achieved will not be discussed in detail. It is only mentioned that this mechanism makes it possible to collapse the two upright walls over the bottom surface, the connecting flap 7 and the connection zone 9 connected thereto being locked between the two collapsed walls 2 and 3.

While it is conventional, as in the case of the box described in GB-A-2 196 608, to form corner support elements from flaps which are situated laterally in line with one of the upright box walls meeting at a corner, in the box according to the invention, for each corner zone a composite corner support panel 10 is connected to the upright wall 2 through the free edge thereof (i.e., the edge located opposite the fold line 4) via a fold line 11 of limited length.

In the embodiment shown, the corner support panel 10 is made up of a plurality of corner support panels 10a-10f interconnected by fold lines 12a-12e.

From the blank according to Fig. 1, corner supports with a flat tubular structure can be obtained in two ways, to be explained hereinafter with reference to Figs. 2-3 and Fig. 4, respectively.

In the box in erected position as depicted in Fig. 2, the upright walls 2 and 3 in each corner zone are interconnected by means of the connecting flap 7 and the connection zone 9 bounded by the 45° fold line 8.

The composite corner support panel 10 is folded about the fold line 11 over the inside of the upright wall 2. The corner support panel 10a is fixed by means of a locking tab G and a locking slot S provided for that purpose in the bottom surface 1, in a position wherein this panel 10a abuts against the inside of the connecting flap 7 and such that the corner support panels 10b and 10c are spaced from the corner rib (fold line 6). Between, on the one hand, the corner support panels 10b and 10c and, on the other, the portions of the upright wall 2 and the connecting flap 7 that adjoin the corner rib (fold line 6), a substantially L-shaped tubular space LK is present, which is part

of the corner support structure. The free upper edges of the corner support panels 10b and 10c form bearings for a superjacent box in a stack.

In the embodiment according to Figs. 2 and 3, the panel 10e extends in the direction of the fold line 12b between the corner support panels 10b and 10c and the panel 10f is arranged against the panel 10b and attached thereto. Thus, a second flat tubular space PK is formed, which overlaps one of the legs of the L-shaped tubular space LK, so that the corner support structure is enhanced and additionally stabilized.

In the variant embodiment of the blank according to Fig. 1A, the connecting flaps 7 and the adjacent parts 10a of the composite corner support panels 10 are provided with corresponding fold lines 15, 15'. These fold lines 15, 15' facilitate the corner zones being pulled open, as appears from Fig. 3A.

The embodiment shown in Fig. 4 only differs from the embodiment shown in Figs. 2 and 3 in that the corner support panels 10e and 10f extend in different ways. The panel 10e is arranged along the corner support panels 10c and 10d and the panel 10f is folded back about the fold line 12e over the panel 10e. Thus, the flat tubular space PK is no longer present and instead, a stabilization is obtained by doubling of the material (triplication), albeit with a smaller bearing for superjacent boxes in a stack. Otherwise, both embodiments can be realized starting from the same blank shown in Fig. 1.

Figs. 1-4 show centering tabs 13, 14 designated at the connecting flap 7 and the panel 10a, respectively. In the erected position of the box, they project above the level of the box opening. In the bottom of the box centering openings C are present, such that in a stack of boxes the centering tabs 13, 14 reach into the centering openings C of a superjacent box.

This manner of centering and, accordingly, laterally stabilizing a stack of boxes is part of the conventional art, at any rate as regards the centering tab 13 on the connecting flap 7. A drawback thereof is that owing to the position of these centering means on the box edges, an accurate positioning of successive boxes on a stack is necessary to realize the centering effect and lateral stabilization.

The present invention makes use of the corner support panels 10 extending on the inside of each box corner and is based on the insight that by providing centering tabs 14' on corner support panels 10e, 10f and forming corresponding centering slots C' in the bottom 1, spaced from the corner rib 6, the above-mentioned drawbacks of the known centering and stabilizing means are avoided and a box can be placed on a stack by placing it approximately on the topmost box of the stack and subse-

quently centering it by shifting action, the centering tabs 14' of the subjacent box being automatically received in the centering slots C' of the superjacent box.

In Fig. 1 the centering tabs 14' and the centering slots C' are indicated as an alternative by means of dotted lines and Fig. 5 shows such a box in erected position.

Claims

1. A ready-to-use box that can be made from a blank by folding and adhesion, comprising a bottom surface (1) and upright longitudinal and transverse walls (2, 3) connected to said bottom surface by four fold lines (4, 5) bounding said bottom surface, whilst at the corners where upright walls (2, 3) meet, one of the upright walls (2) is provided with a connecting flap (7) connected to said upright wall by a fold line (6), and the other upright wall (3) comprises a triangular connection zone (9) bounded by a fold line (8) starting from the bottom corner point at a 45° angle, which connection zone, after being folded back, as viewed from the interior of the box, against the outside of that upright wall (3), is attached by adhesion to the outside of said connecting flap (7), whilst collapsible tubular corner support structures are formed from corner support flaps (10a-f) provided with fold lines (12a-12e), said corner support flaps being connected (11) to an upright wall part (2) of the box, **characterized in that** each tubular corner support structure comprises a corner support panel (10c), which, in the erected condition of the box, extends from a first upright box wall (2) to the corresponding corner and terminates at a distance therefrom in a fold line (12b), from which fold line (12b) a second corner support panel (10b) extends to the adjacent second upright box wall (3), and a third corner support panel (10e) likewise extends from the first upright box wall (2), at an acute angle relative to the first corner support panel (10c), to the fold line (12b) between the first (10c) and the second corner support panel (10b).
2. A ready-to-use box with corner support structure according to claim 1, characterized in that, in the erected position of the ready-to-use box, in each corner zone a substantially flat tube (LK) is present, having a generally L-shaped cross-section as seen in top plan view of the erected box, this tube (LK) being bounded on the outside by parts of the upright box walls (2, 3) meeting in that corner zone and on the inside by said first (10c) and second corner

support panels (10b).

3. A ready-to-use box with corner support structure according to claim 1 or 2, characterized in that a fourth corner support panel (10f), connected to the third corner support panel (10e) via a fold line (12e), is folded back over the third corner support panel (10e), the fold line (12e) being situated near the fold line (12b) between the first (10c) and the second corner support panel (10b).
5
10
4. A ready-to-use box with corner support structure according to claim 1 or 2, characterized in that a fourth corner support panel (10f), connected to the third corner support panel (10e) via a fold line (12e), is connected with the second corner support panel (10b), such that the fold line (12e) between the third (10e) and the fourth corner support panel (10f), in the collapsed condition of the box, is situated close to the fold line (12b) between the first (10c) and the second corner support panel (10b).
15
20
25
5. A ready-to-use box according to any one of the preceding claims, comprising centering tabs projecting above the upper edge of the box in the erected condition of the box, characterized in that the centering tabs (14') are formed on the composite corner support panel (10), such that, in the erected box, as viewed from the interior of the box, they extend upwardly from the corner support structure on the inside of the corner ribs (6) and the bottom surface (1) is provided with corresponding centering slots (C').
30
35
6. A ready-to-use box according to any one of the preceding claims, characterized in that in the connecting flaps (7) and in the adjacent parts (10a) of the composite corner support panels (10), corresponding inclined fold lines (15, 15') are provided.
40
45

50

55

5

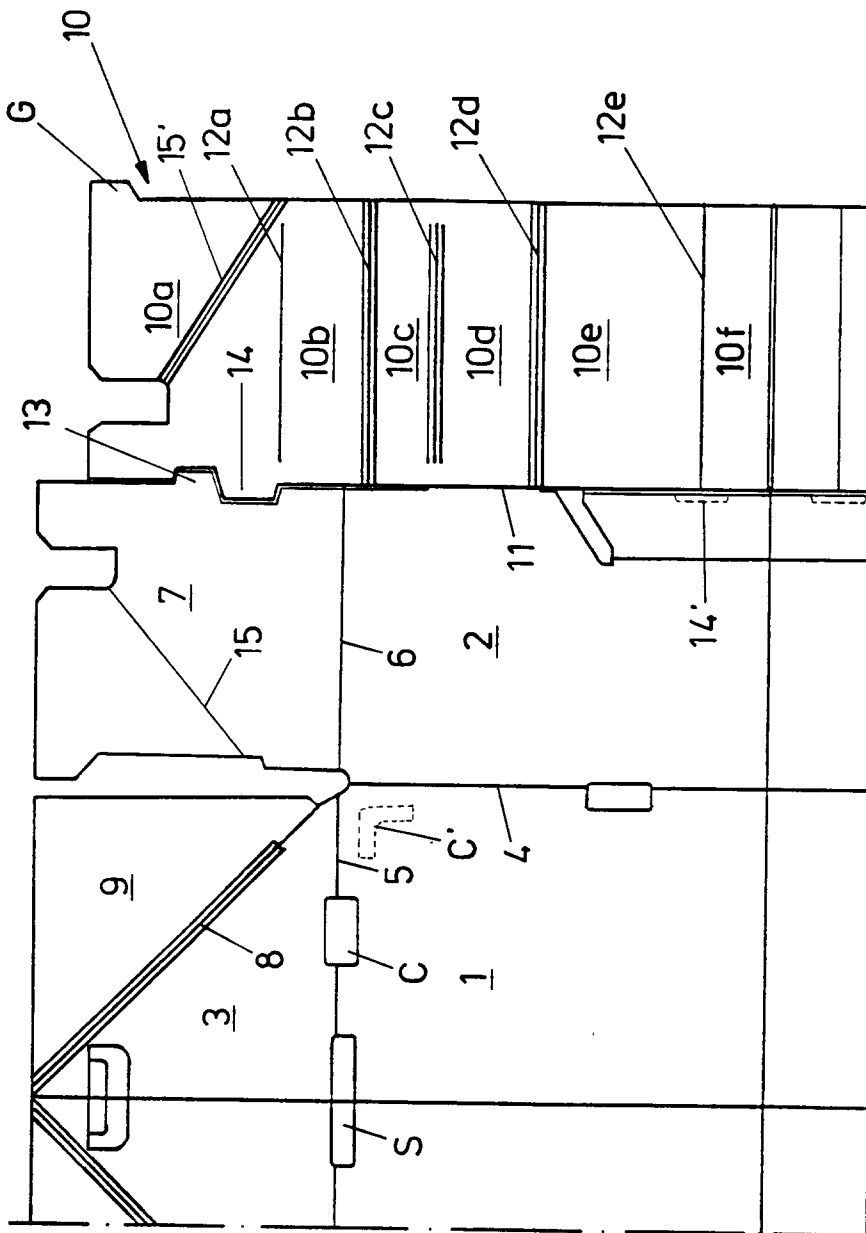

FIG. 1A

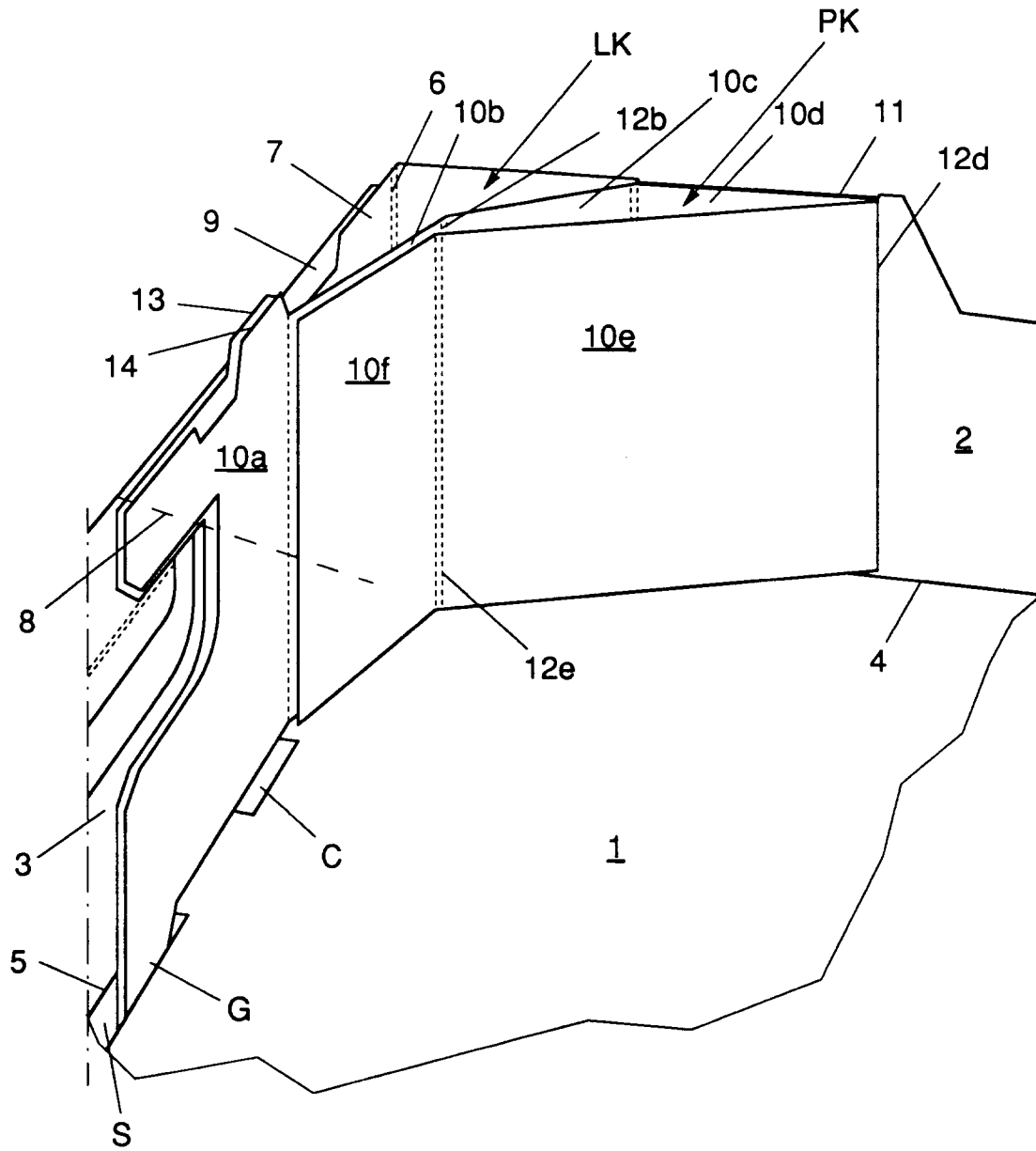

FIG. 2

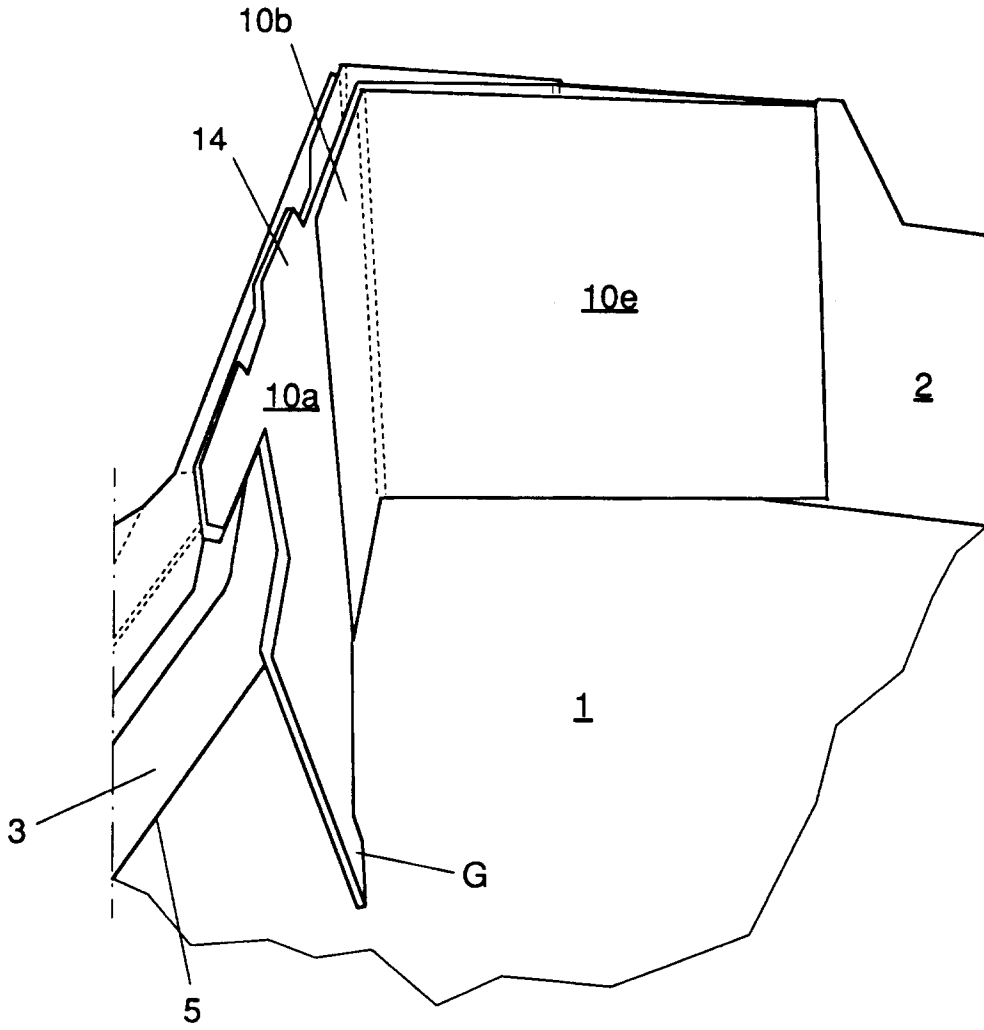

FIG. 3

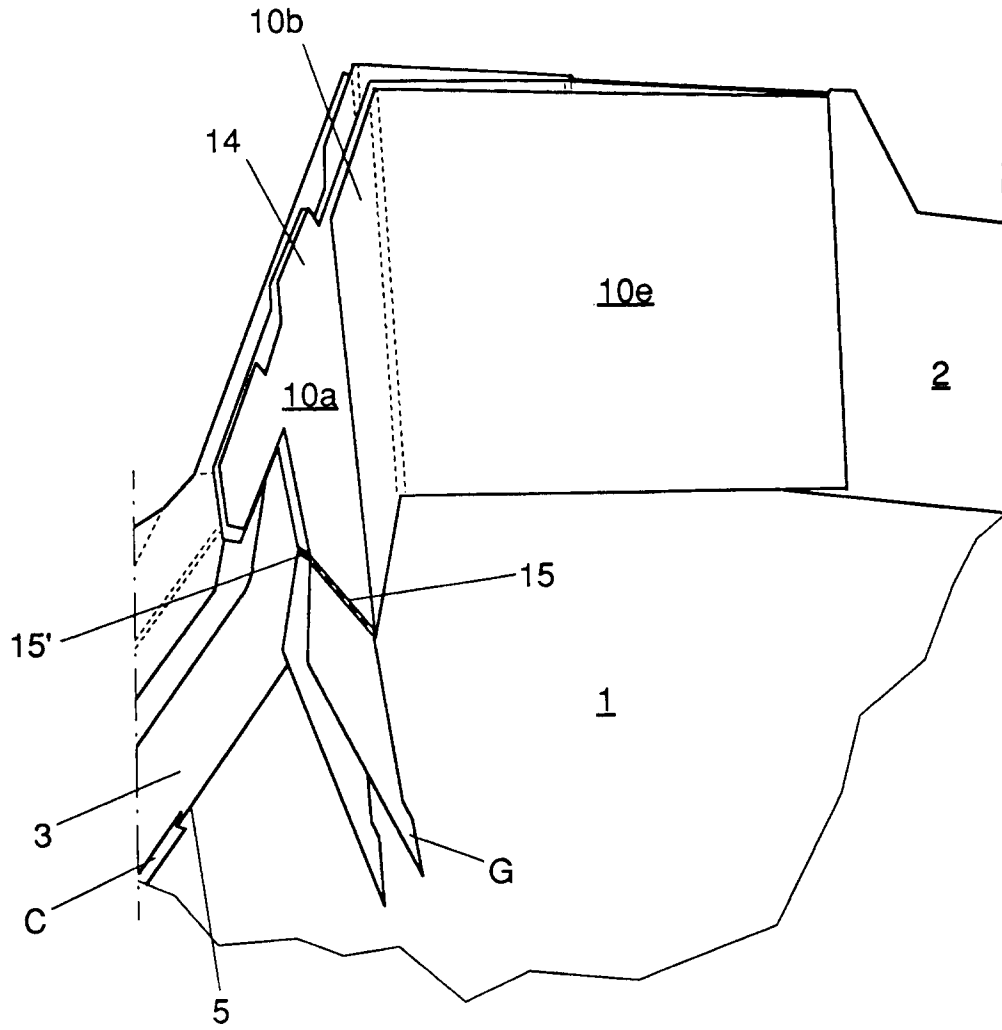

FIG. 3A

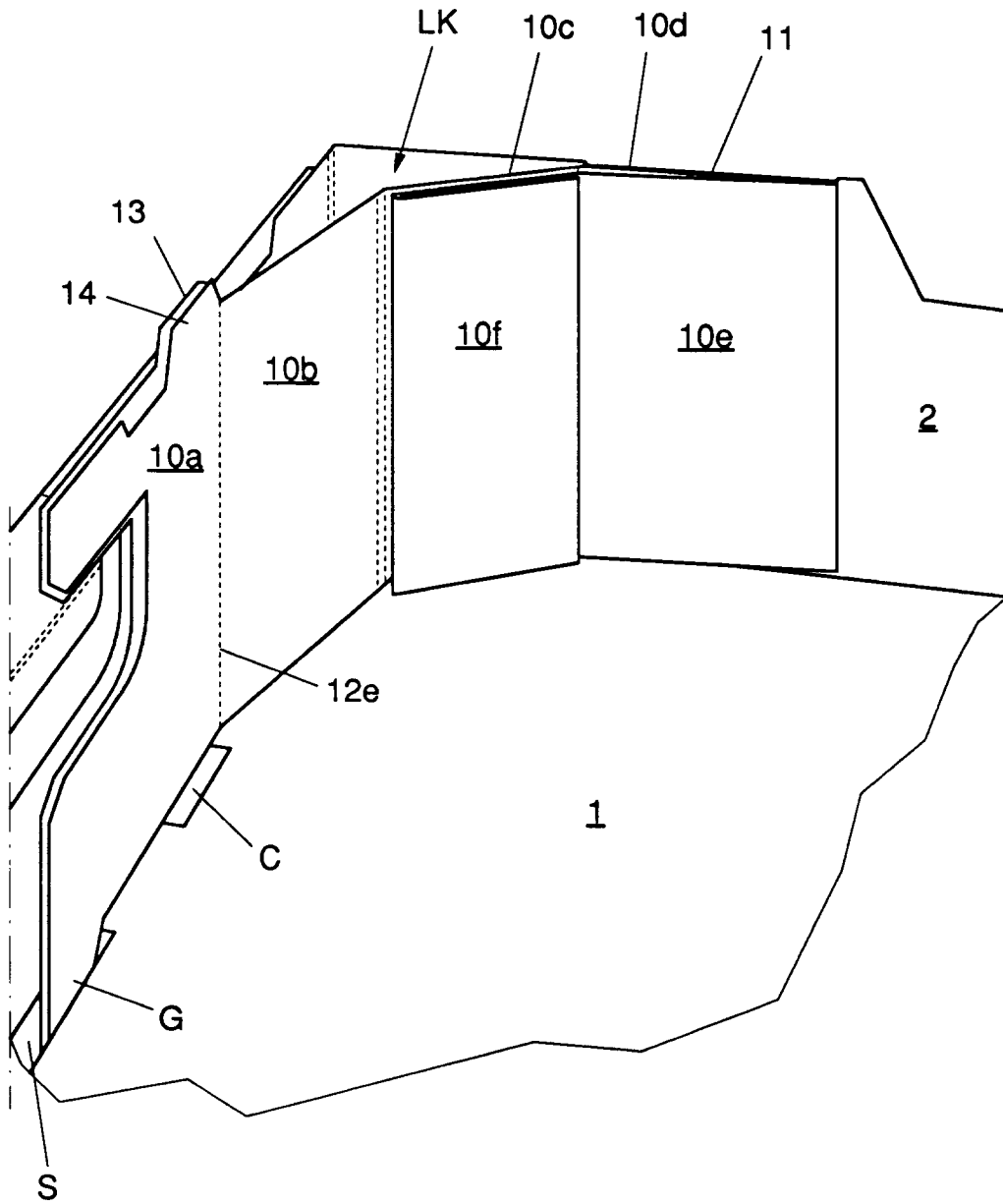

FIG. 4

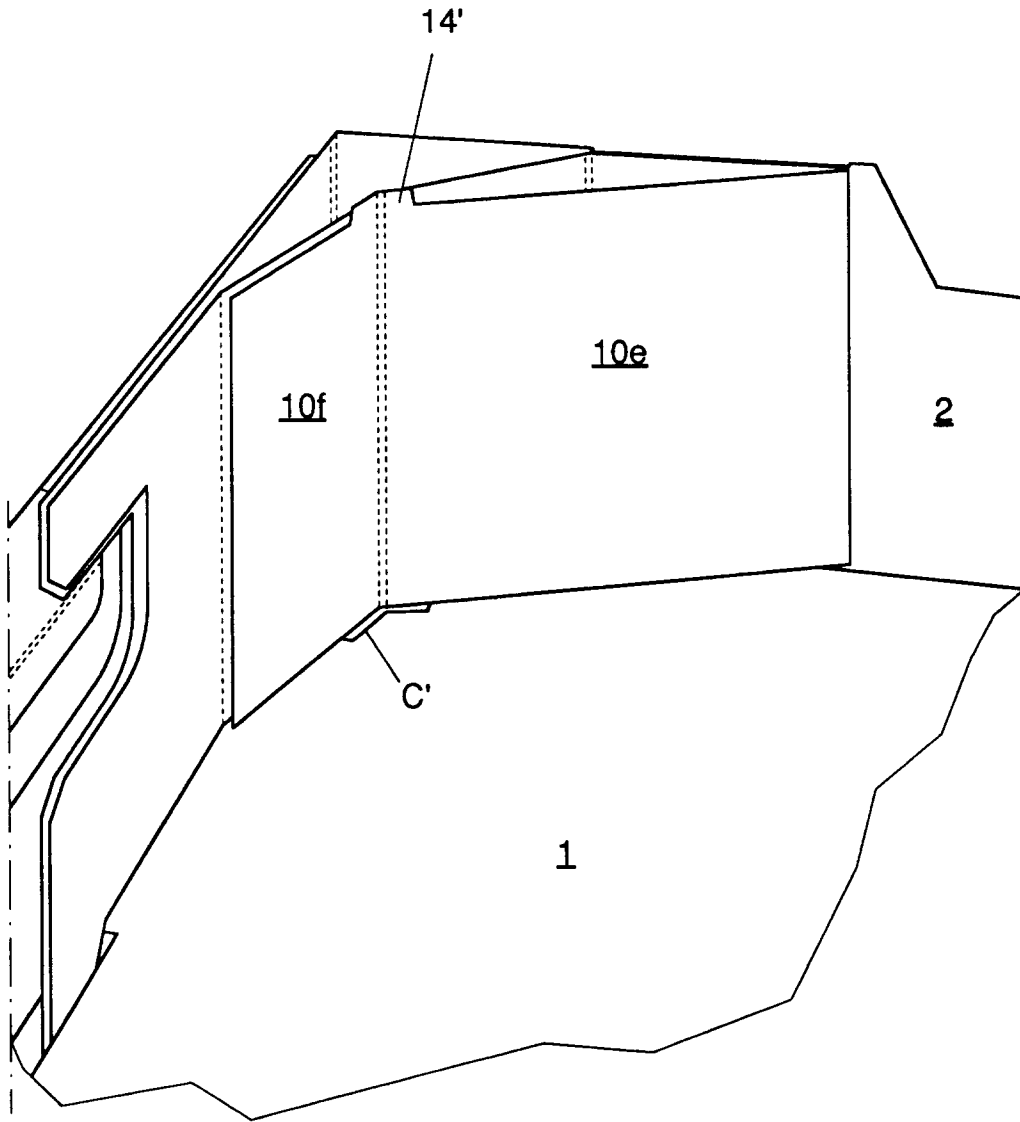

FIG. 5



| DOCUMENTS CONSIDERED TO BE RELEVANT | | | |
|--|--|---|---|
| Category | Citation of document with indication, where appropriate, of relevant passages | Relevant to claim | CLASSIFICATION OF THE APPLICATION (Int. Cl.5) |
| A | FR-A-2 306 888 (ALLARD) * figures * --- | 1 | B65D5/00 B65D5/36 |
| A | EP-A-0 083 133 (GELRIA) * page 6, line 6 - page 6, line 18; figures * --- | 1 | |
| A | NL-C-94 977 (Z.DE ZEEUW) * figures * --- | 1 | |
| A | EP-A-0 444 004 (PIET) * figures * --- | 1 | |
| A | US-A-1 912 822 (CAPSHAW) * page 1, line 79 - page 2, line 32; figures 4,6 * ----- | 6 | |
| | | | TECHNICAL FIELDS SEARCHED (Int. Cl.5) |
| | | | B65D |
| The present search report has been drawn up for all claims | | | |
| Place of search THE HAGUE | | Date of completion of the search 28 SEPTEMBER 1993 | Examiner NEWELL P.G. |
| CATEGORY OF CITED DOCUMENTS X : particularly relevant if taken alone Y : particularly relevant if combined with another document of the same category A : technological background O : non-written disclosure P : intermediate document T : theory or principle underlying the invention E : earlier patent document, but published on, or after the filing date D : document cited in the application L : document cited for other reasons & : member of the same patent family, corresponding document | | | |