



Publication number : **0 575 204 A3**

**EUROPEAN PATENT APPLICATION**

Application number : **93304838.1**

Int. Cl.<sup>5</sup> : **B41J 2/04, B41J 2/045**

Date of filing : **21.06.93**

Priority : **19.06.92 US 906091**

Date of publication of application :  
**22.12.93 Bulletin 93/51**

Designated Contracting States :  
**DE FR GB IT**

Date of deferred publication of search report :  
**07.12.94 Bulletin 94/49**

Applicant : **TEKTRONIX, INC.**  
**Wilsonville Industrial Park,**  
**26600 S.W. Parkway Avenue**  
**Wilsonville, Oregon 97070-1000 (US)**

Inventor : **Stanley, Douglas M., c/o Tektronix,**  
**Inc.**  
**26600 S W Parkway Avenue,**  
**PO Box 1000,**  
**M/S 63-LAW**  
**Wilsonville, Oregon 97070-1000 (US)**

Inventor : **Roy, Joy, c/o Tektronix, Inc.**  
**26600 S W Parkway Avenue,**  
**PO Box 1000,**  
**M/S 63-LAW**

**Wilsonville, Oregon 97070-1000 (US)**  
Inventor : **Schoening, Susan C., c/o Tektronix,**  
**Inc.**

**26600 S W Parkway Avenue,**  
**PO Box 1000,**  
**M/S 63-LAW**

**Wilsonville, Oregon 97070-1000 (US)**

Inventor : **Anderson, Jeffrey J., c/o Tektronix,**  
**Inc.**

**26600 S W Parkway Avenue,**  
**PO Box 1000,**  
**M/S 63-LAW**

**Wilsonville, Oregon 97070-1000 (US)**

Representative : **Lawrence, Malcolm Graham**  
**Hepworth, Lawrence, Bryer & Bizley**  
**2nd Floor, Gate House South**  
**West Gate**  
**Harlow Essex CM20 1JN (GB)**

**Method of operating an ink jet to achieve high print quality and high print rate.**

A drop-on-demand ink jet print head (9) has an ink chamber (22) coupled to a source of ink (11), and an ink drop orifice (103) with an outlet (14,14a,14b). An acoustic driver (36) produces a pressure wave in the ink and causes the ink to pass outwardly through the ink drop orifice and outlet (14,14a,14b). The driver is driven with bipolar drive pulses (100) having a refill pulse component (102) and an eject pulse component (104) of a polarity which is opposite to the refill pulse component (102). The refill and eject pulse components are separated by a wait period (106). The drive pulses may be adjusted to minimize their energy content at a frequency corresponding to the dominant acoustic resonance frequency of the ink jet print head (9). This will accelerate drop breakup, optimize drop shape and minimize drop speed variations over the range of drop printing rates. The size of the ink drops may be varied, such as by driving the acoustic driver (36) with varying drive signals, preferably utilizing individual or combinations of a plurality of bipolar drive pulses (100). The ink jet printer of the present invention may be used to print with a wide variety of inks, including phase change (hot melt) inks to achieve high print quality at high print rates.

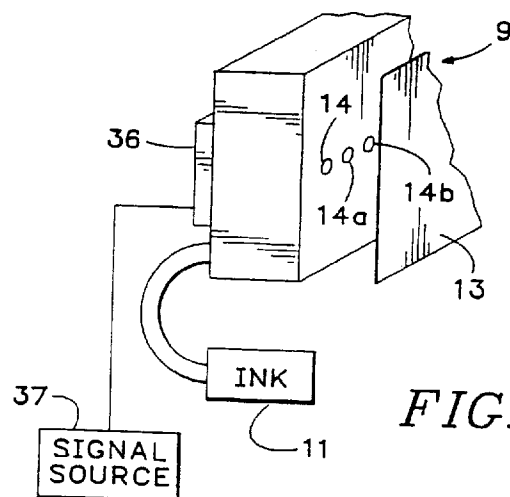

**FIG. 1**

**EP 0 575 204 A3**



European Patent  
Office

EUROPEAN SEARCH REPORT

Application Number  
EP 93 30 4838

DOCUMENTS CONSIDERED TO BE RELEVANT			
Category	Citation of document with indication, where appropriate, of relevant passages	Relevant to claim	CLASSIFICATION OF THE APPLICATION (Int.Cl.5)
D,X	EP-A-0 467 656 (TEKTRONIX) * the whole document *	1	B41J2/04 B41J2/045
D,A	---	2-8	
A	PATENT ABSTRACTS OF JAPAN vol. 12, no. 294 (M-730) 11 August 1988 & JP-A-63 071 355 (FUJITSU) 31 March 1988 * abstract *	1-8	
A	US-A-4 491 851 (MIZUNO) * column 3, line 6 - line 21; figures 5A-5D,6 *	1-8	
A	US-A-4 734 705 (REZANKA) * column 4, line 45 - column 10, line 64; figures 1-6 *	1-8	
A	PATENT ABSTRACTS OF JAPAN vol. 12, no. 332 (M-738) 8 September 1988 & JP-A-63 094 851 (CANON) * abstract *	1-8	
A	IBM TECHNICAL DISCLOSURE BULLETIN., vol.24, no.2, July 1981, NEW YORK US pages 939 - 941 'Unimorph Drop Generator for an Ink Jet Printer'	1-8	TECHNICAL FIELDS SEARCHED (Int.Cl.5) B41J
A	US-A-4 523 200 (HOWKINS)		
A	EP-A-0 194 852 (EXXON)		
A	EP-A-0 437 062 (TEKTRONIX)		
The present search report has been drawn up for all claims			
Place of search THE HAGUE		Date of completion of the search 29 September 1994	Examiner Adam, E
CATEGORY OF CITED DOCUMENTS		T : theory or principle underlying the invention E : earlier patent document, but published on, or after the filing date D : document cited in the application L : document cited for other reasons ----- & : member of the same patent family, corresponding document	
X : particularly relevant if taken alone Y : particularly relevant if combined with another document of the same category A : technological background O : non-written disclosure P : intermediate document			

EPO FORM 1500 00.02 (P04C01)