

19



Europäisches Patentamt
European Patent Office
Office européen des brevets



11 Publication number:

0 575 694 A1

12

EUROPEAN PATENT APPLICATION

21 Application number: **93102623.1**

51 Int. Cl.⁵: **B65D 77/24, B65D 5/76**

22 Date of filing: **19.02.93**

30 Priority: **23.06.92 IT GE920035 U**

71 Applicant: **MIRA LANZA S.P.A.**
Via Lampedusa 11/A
I-20141 Milano(IT)

43 Date of publication of application:
29.12.93 Bulletin 93/52

72 Inventor: **Berveglieri, Fabrizio**
Vle B. Brea 17
Genova(IT)

84 Designated Contracting States:
AT BE CH DE DK ES FR GB GR IE IT LI LU MC
NL PT SE

74 Representative: **Porsia, Attilio, Dr. et al**
c/o Succ. Ing. Fischetti & Weber
Via Caffaro 3/2
I-16124 Genova (IT)

54 **Carton for powder substances such as washing powders.**

57 Carton for containing powder substances such as washing powders, water softening substances and the like, comprising: a box container (3) in cardboard or some other material suitable for the purpose and a lid (2), the carton being characterised in that said lid (2) is so shaped that its outside has a cavity (22) of complementary shape to that of a measuring device (5) for measuring out the powder substance in question.

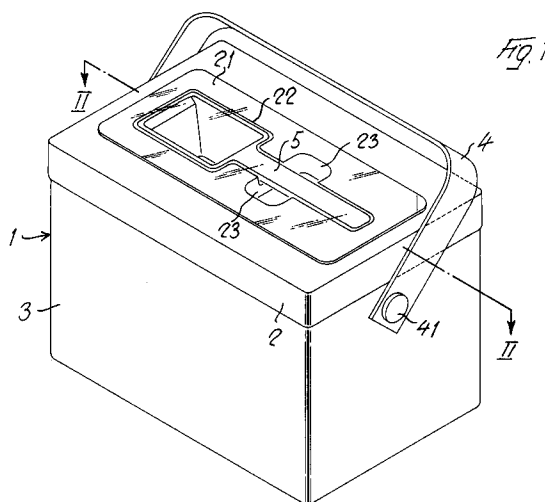

EP 0 575 694 A1

The present invention relates to cartons for containing powder substances such as washing powders, water softening substances and the like, from which measured amounts are to be taken and dispensed.

For this purpose, known cartons of this type are supplied with a measuring device, generally in the form of a scoop or spoon element. This spoon is usually inserted during packaging inside the carton in contact with the powder product.

This means that the user has to hunt for the measuring device in the middle of the powder after opening the packaging, which is not always an easy job. Furthermore, after the product has been measured out, the user has the problem of where to put the measuring device, with the result that the latter is often lost.

It has also been proposed that the measuring device be accommodated inside the carton but stuck in an easily detachable manner, for example by using self-adhesive tapes, to the inside of the lid. Although this solution solves the problem of the measuring device sinking into the powder, it does not overcome the problem of where to put the measuring device after each use.

It has also been proposed that the measuring device be accommodated outside the carton. However, this solution is even worse than the previous one since not only does it not eliminate the problem of where to put the measuring device after measuring out the powder, but also creates problems when stacking the cartons for transport or the like.

The main object of the present invention is therefore to provide means for accommodating the measuring device in the carton in a position where it can easily be accessed by the user, in which these means may also form a seat for stably holding the measuring device after measuring out the powder.

According to a chief characteristic of the present invention, this is achieved by making the lid of the carton out of cardboard or plastic in a more or less thin sheet, and making in this lid a cavity of complementary shape to the shape in plan of the measuring device, this cavity being able to accommodate the measuring device in such a way that the latter does not project beyond the outer surface of the lid.

Advantageously, during the packaging of the carton, after the measuring device has been placed in the cavity of the lid, the cavity is sealed by means of an easily detachable adhesive sheet. Advantageously, this adhesive sheet is a self-adhesive sheet of transparent plastic so that the measuring device can be seen to be present.

Further objects, characteristics and advantages of the carton according to the invention will appear

in more detail in the following description thereof, which refers to the attached drawings in which:

Figure 1 is an isometric drawing of a carton according to the invention, with measuring device inserted in its seat in the lid, and

Figure 2 is an enlarged view of part of the carton shown in Figure 1, showing the lid in section along the transverse plane II-II in Figure 1.

With reference to the drawings, and with particular reference to Figure 1, 1 denotes a carton according to the present model. This carton 1 comprises: a box 3 containing the washing powder and made of cardboard or other material suitable for the purpose; a handle 4 for carrying said carton, fixed to the carton by means of the pins 41; a lid 2 made of more or less thin sheet plastic that has been vacuum thermoformed, or pressed, or otherwise shaped, to produce a cavity 22 for accommodating a spoon-type measuring device 5, said device 5 and said cavity 22 being covered with a self-adhesive sheet 21 of easily removable transparent plastic.

The cavity 22 advantageously has two symmetrical recesses 23 positioned alongside the handle part of the measuring device 5 to enable the user to take the device 5 out of the cavity 22 quickly and easily. In the same way the measuring device can be replaced in said cavity 22 after use. The plastic sheet 21 placed as a closure over the cavity 22 accommodating the measuring device 5 has the function of protecting the latter during storage and transport to prevent it from being lost. The user can easily remove this sheet to get at the measuring device 5.

By this means a convenient association is provided of a measuring device with a washing powder pack, which makes the manufacturer's operations simpler as in this way he can easily join together the measuring device and the carton without concerning himself with whether the user will be able to find the measuring device or how the carton itself can be transported. At the same time the consumer's task is made easier in that he no longer has the inconvenience of searching for the measuring device inside the package, and need have no concern about losing it throughout the use of the powder pack; instead he now has a measuring device 5 that is easy to find and just as easy to put away in its seat in said cavity 22 after use.

Clearly, the invention is not restricted to the embodiment illustrated and described, but rather comprises all such variants and modifications coming within the scope of the same innovative design as confer equal utility. Thus, for example, instead of or in addition to the adhesive plastic sheet 21 used to seal the cavity 22, a suitable removable overlid made of transparent plastic or the like may

be used.

Although in the example shown and described, the lid 2 has been indicated as being made of thin sheet plastic, it will be understood that it may be made of cardboard, pressed card, sheet metal or some other material suitable for the purpose. 5

Claims

1. Carton for containing powder substances such as washing powders, water softening substances and the like, comprising: a box container (3) in cardboard or some other material suitable for the purpose and a lid (2), the carton being characterised in that said lid (2) is so shaped that its outside has a cavity (22) of complementary shape to that of a measuring device (5) for measuring out the powder substance in question. 10
15
20
2. Carton according to Claim 1, in which said cavity (22) in said lid (2) has two symmetrical recesses (23) for facilitating the grasping of a part of the measuring device (5), such as its handle, between two fingers of the user's hand in order to facilitate the removal of the measuring device (5) from the cavity (22). 25
3. Carton according to the preceding claims, in which said measuring device (5) and said complementary cavity (22) are covered by a transparent plastic sheet (21), preferably a self-adhesive sheet (21) that can be easily removed. 30
35
4. Carton according to the preceding claims, also comprising a removable overlid made of transparent plastic. 40
5. Carton according to the preceding claims, characterised in that the lid (2) is made of thin plastic, cardboard, pressed card, sheet metal or the like. 45
50
55

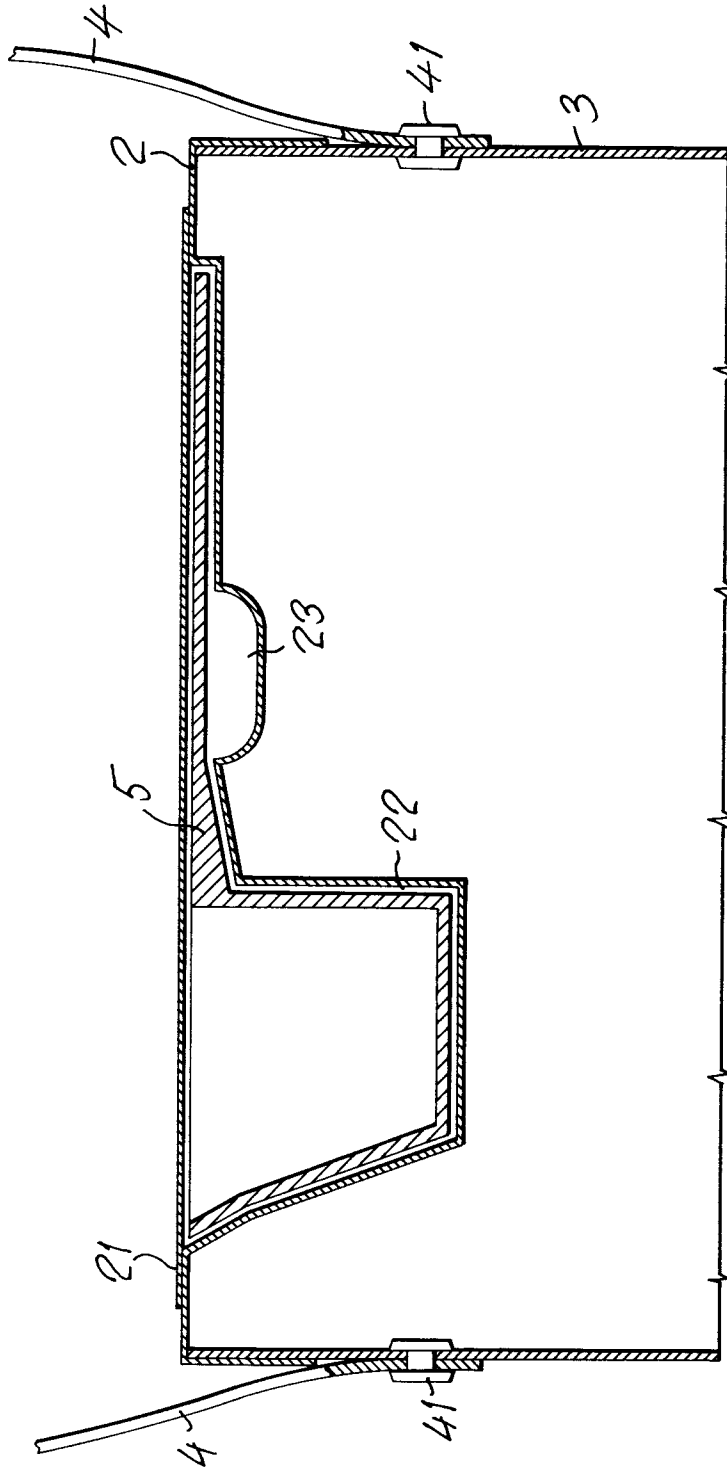

Fig. 2



DOCUMENTS CONSIDERED TO BE RELEVANT

Category	Citation of document with indication, where appropriate, of relevant passages	Relevant to claim	CLASSIFICATION OF THE APPLICATION (Int. Cl.5)
A	WO-A-9 208 658 (BERGNER) * page 6, line 13 - page 7, line 11; figures 1-3 * ---	1,2,5	B65D77/24 B65D5/76
A	DE-A-3 242 257 (HERTEL) * claims 1-3,11-14; figures 12,13 * ---	1-3,5	
A	DE-A-3 521 289 (BRUSA) * page 8, line 15 - page 9, line 21; figures 1-3 * ---	1-3,5	
A	NL-A-8 601 653 (THOMASSEN) * page 2, line 20 - page 4, line 6; figures 1-14 * -----	1-5	
			TECHNICAL FIELDS SEARCHED (Int. Cl.5)
			B65D
The present search report has been drawn up for all claims			
Place of search THE HAGUE		Date of completion of the search 24 SEPTEMBER 1993	Examiner VANTOMME M.A.
CATEGORY OF CITED DOCUMENTS X : particularly relevant if taken alone Y : particularly relevant if combined with another document of the same category A : technological background O : non-written disclosure P : intermediate document		T : theory or principle underlying the invention E : earlier patent document, but published on, or after the filing date D : document cited in the application L : document cited for other reasons & : member of the same patent family, corresponding document	